



Mini GPS/BDS Unit (AT6558)

SKU: U032

This is the M5Unit version of **GPS**, integrates a Zhongke WeibeiDou navigation chip **AT6558** and a amplification chip **MAX2659** used for amplifying antenna signal.

AT6558 is highly performance, supports many types of satellite navigation system,able to receive satellite signals on 56 channels GNSS signal from 6 satellite navigation system, joint location, navigation, timing and more. The module is able to obtain accurate global location information. quick and accurate positioning for anywhere in the city, in the canyon, under the overhead, and inside the car.

The module can be widely used in vehicle monitoring, bus reporting, car navigation, onboard navigation, notebook navigation and other products.

You can plug it into port C on M5core via GROVE cable, which is a standard UART interface.

UART settings :

- Baudrate(**default: 9600bps**)
- Start bits(1 bit)
- Stop bits(1 bit)
- Parity(no)

Product Features

- Functional specification
 - Positioning accuracy: 2.5 meters (CEP50, open space)
 - Channel: 56
 - Support single system positioning of BDS/GPS/GLONASS satellite navigation systems, or multi-system joint positioning in any combination
 - Support D-GNSS differential positioning
 - Positioning update frequency: 1-10Hz
 - Maximum height: 1800 m
 - Maximum speed: 515 m/s
 - Maximum acceleration: ≤ 4 G
- Low power consumption
 - BDS/GPS dual mode continuous operation: $<23\text{mA}$ (@3.3V)
 - Standby: $<10\mu\text{A}$ (@3.3V)
- Sensitivity
 - Tracking: -162dBm
 - Capture: -148dBm
 - Cold start: -146dBm
- Start Time
 - Cold start: 35 seconds
 - Warm start: 32 seconds
 - Hot start: 1 second
- Operating temperature: -40~85°C
- Two Lego-compatible holes

Kit includes

- 1x GPS Unit
- 1x Grove Cable

Application

- Car, ship positioning and navigation
- Smart law enforcement positioning

- Documents

- [\[Datasheet\] - AT6558 - MAX2659](#)
- [TinyGPS++ library](#)
- [CASIC multimode satellite navigation receiver protocol specification](#)
- [GnssToolKit3\(Windows Version\)](#)

Example

Arduino IDE

To get the complete code [GPSRaw.ino](#), please click [here](#).

```
#include <M5Stack.h>

/* By default, GPS is connected with M5Core through UART2 */
HardwareSerial GPSRaw(2);

void setup() {
  M5.begin();
  GPSRaw.begin(9600);// GPS init
  Serial.println("hello");
  termInit();
}

void loop() {
  // put your main code here, to run repeatedly:
  if(Serial.available()) {
    int ch = Serial.read();
    GPSRaw.write(ch);
  }
  if(GPSRaw.available()) {
    int ch = GPSRaw.read();// read GPS information
    Serial.write(ch);
    termPutchar(ch);
  }
}
```

Once you download the example code [GPSRaw.ino](#), when device start, following information will print by uart, you can either display with M5 core screen or PC.

```
$GNGGA,063012.000,2234.87140,N,11357.22414,E,1,06,4.2,7.3,M,0.0,M,,*7D
$GNGLL,2234.87140,N,11357.22414,E,063012.000,A,A*4C
$GPGSA,A,3,01,09,11,18,23,,,,,,,,6.3,4.2,4.7*32
$BDGSA,A,3,13,,,,,,,,,6.3,4.2,4.7*21
$GPGSV,3,1,10,01,54,164,33,04,,22,08,46,019,,09,23,230,24*40
$GPGSV,3,2,10,11,81,200,12,18,65,110,26,23,14,195,25,27,18,041,*78
$GPGSV,3,3,10,28,10,300,15,30,33,319,*7C
$BDGSV,1,1,01,13,43,195,29*5A
$GNRMC,063012.000,A,2234.87140,N,11357.22414,E,0.69,171.74,240419,,,A*7A
$GNVTG,171.74,T,,M,0.69,N,1.27,K,A*2C
$GNZDA,063012.000,24,04,2019,00,00*46
$GPTXT,01,01,01,ANTENNA OPEN*25
```

Analysis:

\$GNRMC,063012.000,A,2234.87140,N,11357.22414,E,0.69,171.74,240419,,,A*7A

Indicates that the positioning information is: UTC time is 06:30:12, north latitude 22.58119°, east longitude 113.95357°, April 24, 2019

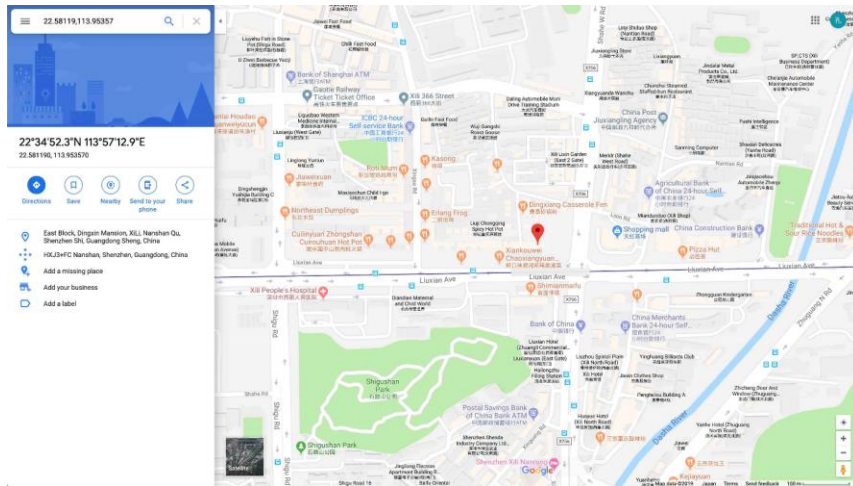

32.2.14.1 Recommended Minimum data

Message	RMC		
Description	Recommended Minimum data		
Firmware			
Type	Output Message		
Comment	<p>The output of this message is dependent on the currently selected datum (default: WGS84)</p> <p>The recommended minimum sentence defined by NMEA for GNSS system data.</p>		
Message Info	ID for CFG-MSG	Number of fields	
	0xF0 0x04	16	

Message Structure:

\$xxRMC,time,status,lat,NS,long,EW,spd,cog,date,mv,mvEW,posMode,navStatus*cs<CR><LF>

Example:

\$GPRMC,083559.00,A,4717.11437,N,00833.91522,E,0.004,77.52,091202,,A,V*57

Field No.	Name	Unit	Format	Example	Description
0	xxRMC	-	string	\$GPRMC	RMC Message ID (xx = current Talker ID)
1	time	-	hhmmss.ss	083559.00	UTC time, see note on UTC representation
2	status	-	character	A	Status, V = Navigation receiver warning, A = Data valid, see position fix flags description
3	lat	-	ddmm. mmmm	4717.11437	Latitude (degrees & minutes), see format description
4	NS	-	character	N	North/South indicator
5	long	-	dddmm. mmmm	00833.91522	Longitude (degrees & minutes), see format description
6	EW	-	character	E	East/West indicator
7	spd	knot s	numeric	0.004	Speed over ground
8	cog	degr ees	numeric	77.52	Course over ground
9	date	-	ddmmyy	091202	Date in day, month, year format, see note on UTC representation
10	mv	degr ees	numeric	-	Magnetic variation value. Only supported in ADR 4.10 and above.
11	mvEW	-	character	-	Magnetic variation EW indicator. Only supported in ADR 4.10 and above.
12	posMode	-	character	A	Mode Indicator, see position fix flags description NMEA v2.3 and above only
13	navStatus	-	character	V	Navigational status indicator (V = Equipment is not providing navigational status information) NMEA v4.1 and above only
14	cs	-	hexadecimal	*57	Checksum

Schematic

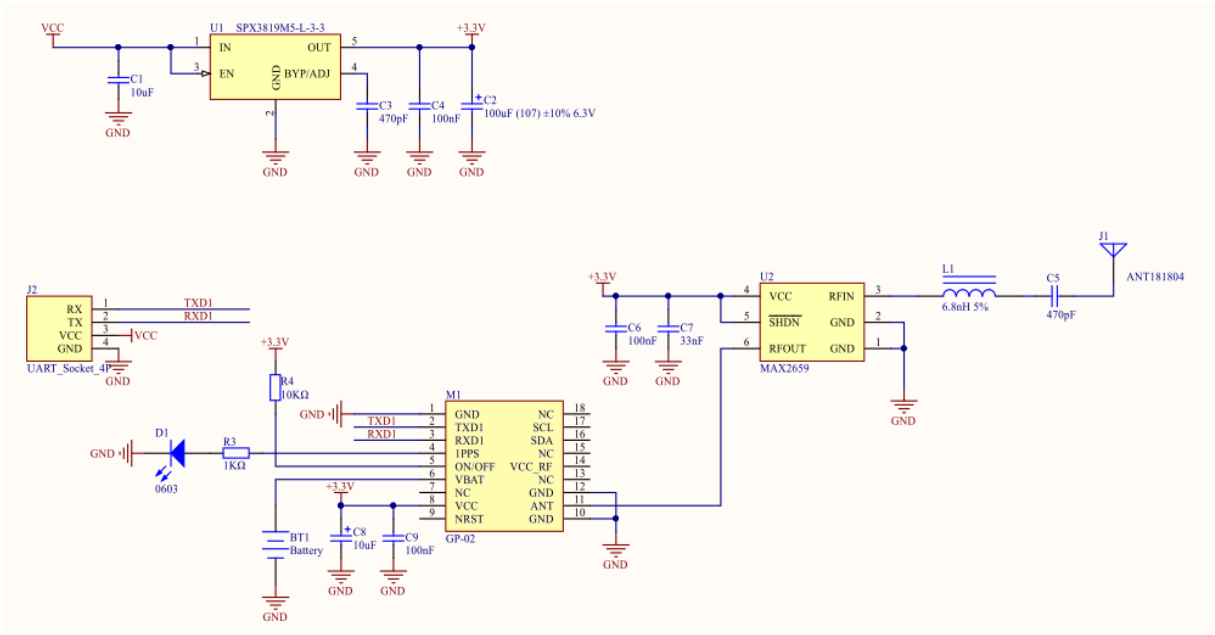

PinMap

M5Core(GROVE C)	U2RXD(GPIO16)	U2TXD(GPIO17)	5V	GND
GPS Unit	Signal Transmitter (TXD)	Signal Receiver (RXD)	5V	GND



<https://m5stack.com/collections/m5-unit/products/mini-gps-bds-unit/12-99-19>