

PART NUMBER	REVISION	DESCRIPTION	FEED TYPE
2150262-2	C	FINE CRIMP HEIGHT ADJUST	PNEUMATIC
7-2150262-2	C	PNEUMATIC AND CRIMP TOOLING KIT	PNEUMATIC
7-2150262-7	B	CRIMP TOOLING KIT	-

ATLANTIC VERSION TERMINATOR INTERFACE ADAPTER

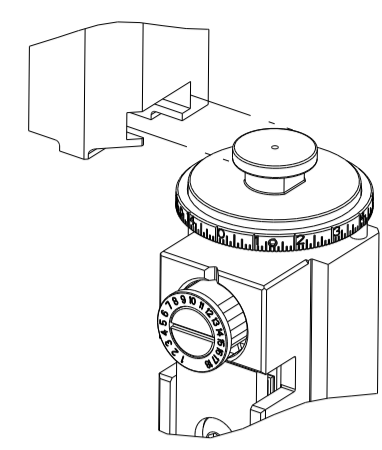

APPLICATOR DATA		
CRIMP	SIZE	TYPE
WIRE	2.79 mm [.110]	F
INSUL	3.94 mm [.155]	F

APPLICATOR INSTRUCTIONS 408-35043

TERMINAL DATA: TE TERMINAL TE CRIMP SPECIFICATION			
TERMINAL NAME: RECEPTACLE, CLUSTER PIN AMPLIVAR, .090 DIA, 1600-4800 CMA			
WIRE STRIP LENGTH		INSULATION DIAMETER RANGE	
6.35-7.11 mm [.250-.280 IN]		Ø1.91-3.18 mm [.075-.125 IN]	
TERMINAL APPLICATION SPECIFICATION	114-2019		
TERMINALS APPLIED			
TE TERMINAL	TE TERMINAL	TE TERMINAL	TE TERMINAL
1742964-1	2385525-1		

WIRE SIZE	CRIMP HEIGHT mm [INCH]	CRIMP HEIGHT REFERENCE SETTING
13.5 MAG	1.88 +/- 0.05 [.074 +/- .002]	8.8
15 MAG	1.68 +/- 0.05 [.066 +/- .002]	11.0
18 MAG	1.47 +/- 0.05 [.058 +/- .002]	12.1



- RECOMMENDED SPARE PARTS.
  - REFER TO SUPPLIED INSTRUCTION SHEET FOR CLEANING, LUBRICATION AND STORAGE OF APPLICATOR.
  - APPLY PART NUMBER 2-23419-6 LOCTITE TO THREADS OF ITEM 242.
  - CRIMP HEIGHT REFERENCE SETTING WAS THE SETTING USED WHEN THE APPLICATOR WAS QUALIFIED AT THE FACTORY. ADJUSTMENT MAY BE NECESSARY WHEN RUNNING APPLICATOR IN THE FIELD.
  - TERMINAL PITCH NOT COMPATIBLE WITH MECHANICAL FEED.
  - FEED TERMINAL OFF OF RECEPTACLE.
  - RECOMMENDED SET-UP WIRE FOR QUALIFICATION ONLY AT THE FACTORY.
  - REFER TO APPLICATION SPECIFICATION FOR ADDITIONAL WIRE CRIMP HEIGHTS.
9. UNLESS SPECIFIED OTHERWISE TORQUE VALUES SHALL BE USED PER DOCUMENT, 101-35000.

**\*WARNING**  
ON INSTALLATION, SET WIRE DISC TO CRIMP HEIGHT REFERENCE SETTING FOR LARGEST WIRE SIZE. CRIMP HEIGHT REFERENCE SETTINGS GREATER THAN THE VALUE SHOWN MAY CAUSE DAMAGE TO THE CRIMP TOOLING, REFER TO THE INSTRUCTION SHEET FOR PROPER SETUP AND ADJUSTMENTS.

**ATLANTIC VERSION**  
Shown on sheets 1 of 4 & 2 of 4  
(Pacific version shown on sheets 3 of 4 & 4 of 4)

LOC	DIST	REVISIONS					
		P	LTN	DESCRIPTION	DATE	OWN	APVD
A	66	1		DEVELOPMENT	21JUN2012	YY	SX
		A		RELEASED	30AUG2012	YY	SX
		B		ECR-18-012143	31JUL2018	MZ	KZ
		C		ECR-22-153175	20SEP2022	LG	TE

-	1	1	2119641-1	FEED CAM, AIR FEED	248
-	1	1	2119082-9	CAM, SNAIL, INSULATION ADJUSTMENT	244
-	1	1	2079764-1	WASHER, WAVE SPRING, CREST-TO-CREST	243
-	1	1	2119083-1	RETAINER, INSULATION DIAL	242
-	1	1	2844940-3	AIR FEED MODULE	238
-	1	1	1-18028-0	WASHER, FLAT, REG M8	192
-	REF	REF	994970-2	COUNTER, MAGNETIC	164
-	1	1	455888-7	SPACER, CRIMPER	82
-	1	1	1803607-4	DOCUMENTATION PACKAGE	71
-	2	2	2-18032-2	SCR, SET, FLT PNT, M3 X 10.0	70
-	1	1	2119740-1	TAG, IDENTIFICATION	67
-	2	2	2168078-1	SCREW, DRIVE, RH, RoHS, 2 x .188	66
-	1	1	2168083-2	SCR, SKT HD CAP, RoHS, M4 X 8.0	60
-	1	1	5-18022-5	SCR, HEX HD CAP, M4 X 6.0	59
-	4	4	2168400-4	SHCS, LOW HEAD, RoHS, M4 X 8	57
-	2	2	1-2168083-0	SCR, SKT HD CAP, RoHS, M4 X 10	56
-	2	2	5018030-1	NUT, HEX, REG, RoHS, M3	54
-	2	2	986965-8	NUT, LOCK, HEX, TORQUE (M4)	53
-	1	1	2063961-1	FEED FINGER	51
-	1	1	18023-9	SCR, SKT HD CAP M4 X 6.0	49
-	1	1	2119655-5	APPLICATOR BASIC ASSEMBLY, EF	46
-	1	1	1803517-1	RAM ASSEMBLY, EF ATLANTIC	44
-	1	1	1803602-2	SCR, BHSC, RoHS (M8 X 40)	41
-	8	8	1-18028-2	WASHER, FLAT, REG M4	33
-	2	2	2168083-9	SCR, SKT HD CAP, RoHS, M4 X 20	31
-	2	2	2168083-2	SCR, SKT HD CAP, RoHS, M4 X 8.0	29
-	1	1	240639-1	STRIPPER (MACHINING)	27
-	2	2	1-2168083-5	SCR, SKT HD CAP, RoHS, M4 X 30	25
-	1	1	1752371-5	PLATE, STRIP GUIDE	24
-	2	2	2-22281-3	SPRING, COMPRESSION	22
-	1	1	1803292-1	DRAG	20
-	2	2	1901259-3	GUIDE, LOWER STRIP	18
-	4	4	1-2079383-1	SCR, BHSC, RoHS (M6 X 12)	17
-	1	1	217573-3	TOOL, SIZING	15
-	1	1	1752360-1	SPACER, HOLD-DOWN	13
-	1	1	240644-1	PLATE, REAR SHEAR	11
-	-	-	-	-	10
-	1	1	690482-3	PLATE, FRONT SHEAR	9
1	2	1	819517-4	ANVIL, COMBINATION	8
-	1	1	1-2217206-3	BLADE, SLUG	7
-	1	1	4-240641-8	SPACER	5
-	1	1	238011-2	BLOCK, CRIMPER SPACER	4
1	2	1	3-2119582-6	CRIMPER, INSULATION F PREMIUM	3
-	1	1	455888-3	SPACER, CRIMPER	2
1	2	1	819516-8	CRIMPER, WIRE	1
-	77	72	-2	PART NO	ITEM NO

DIMENSIONS:		TOLERANCES UNLESS OTHERWISE SPECIFIED:		DWG		NAME	
mm	0 PLC ±	1 PLC ±	2 PLC ±	3 PLC ±	4 PLC ±	5 PLC ±	APVD
	ANGLES	FINISH		Y. YIN	21JUN2012	G. BAILEY	21JUN2012
MATERIAL				S. XI	21JUN2012		
				PRODUCT SPEC			
				APPLICATION SPEC			
				WEIGHT			
				CUSTOMER ACCESSIBLE PRODUCTION DRAWING	SCALE 1:1	SHEET 1 OF 4	REV C

LOC	DIST	REV	DATE	BY	APPV
A	66				

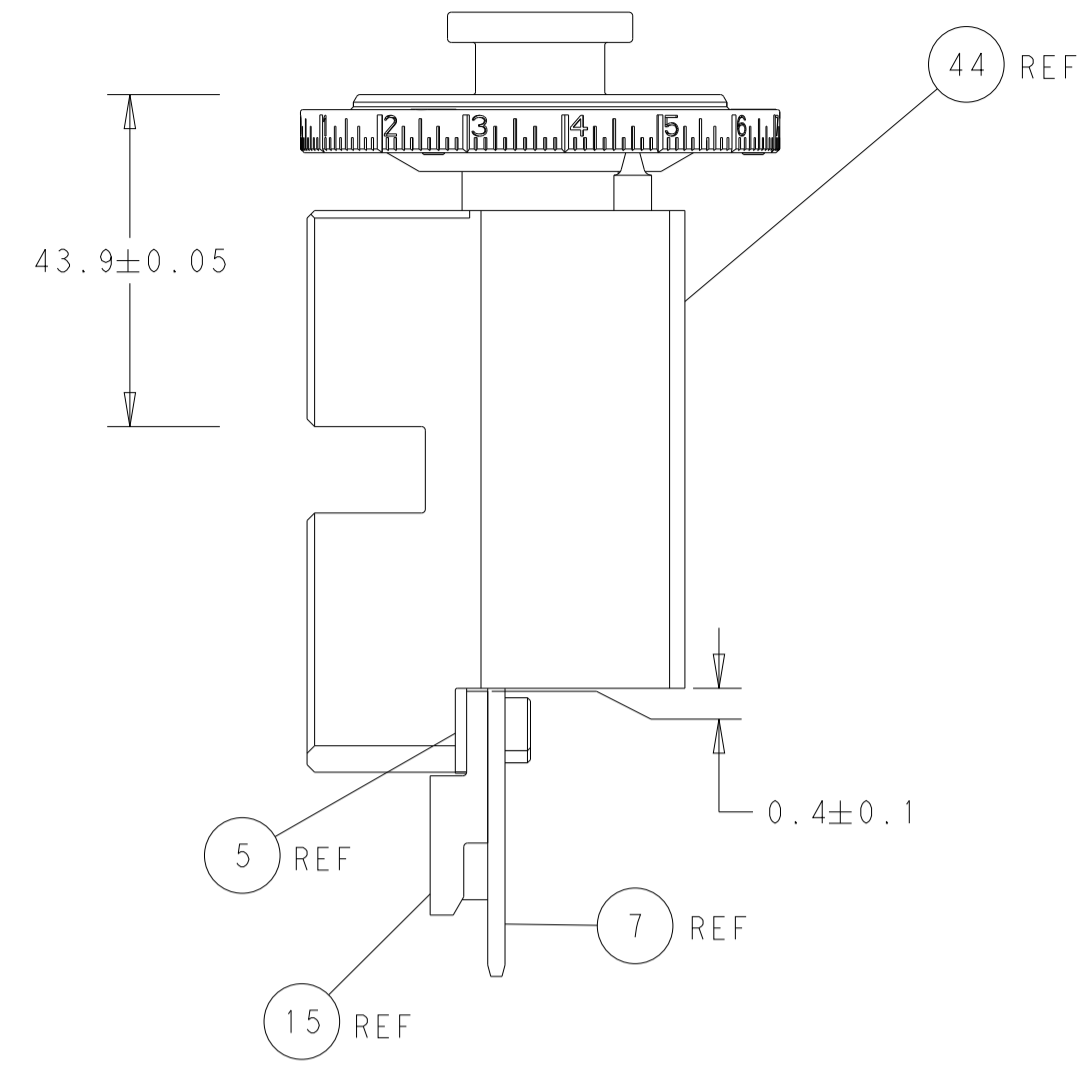

RAM AND HOLDDOWN SET-UP

FEED TYPE

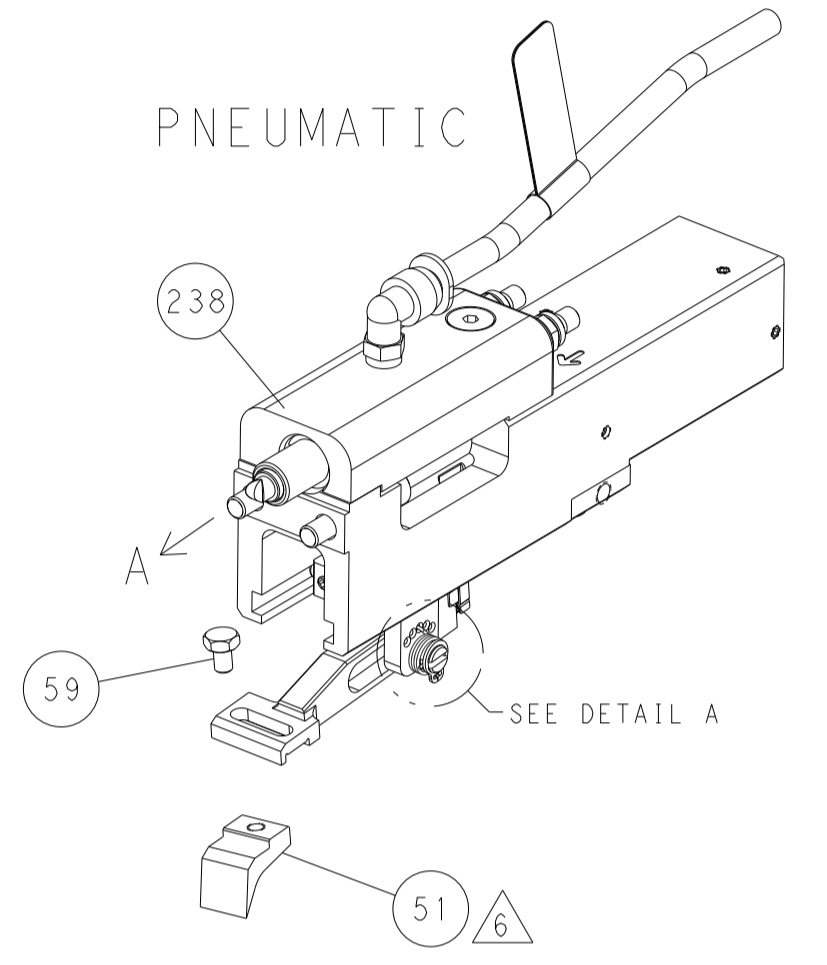
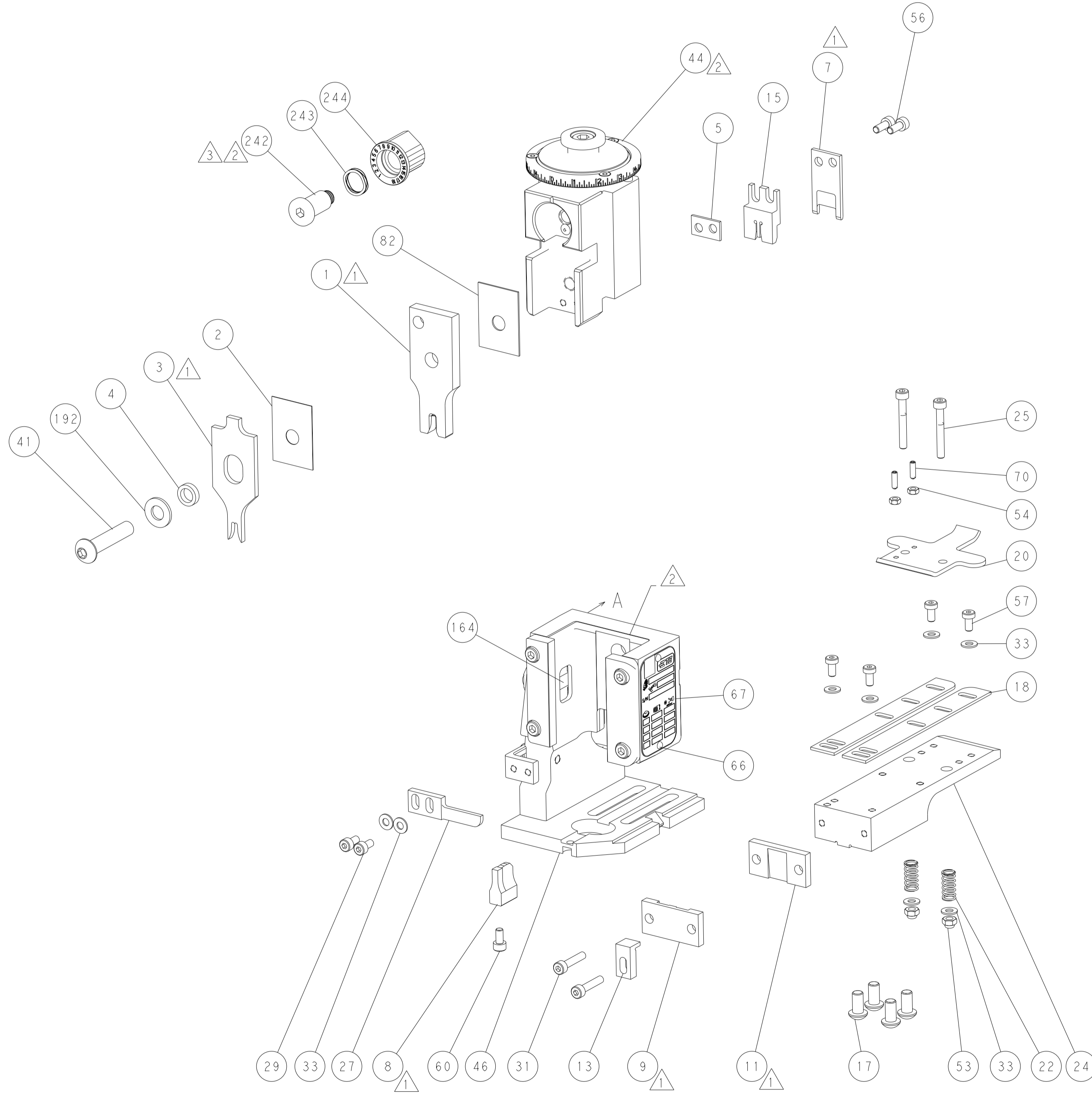

FEED SPRING SETTING POSITION

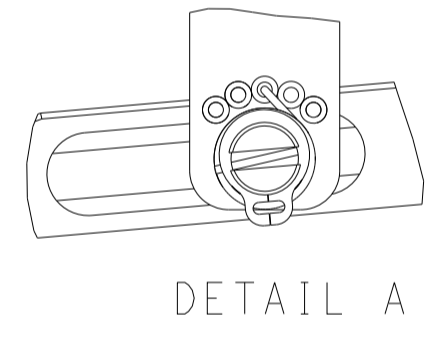

CAM POSITION

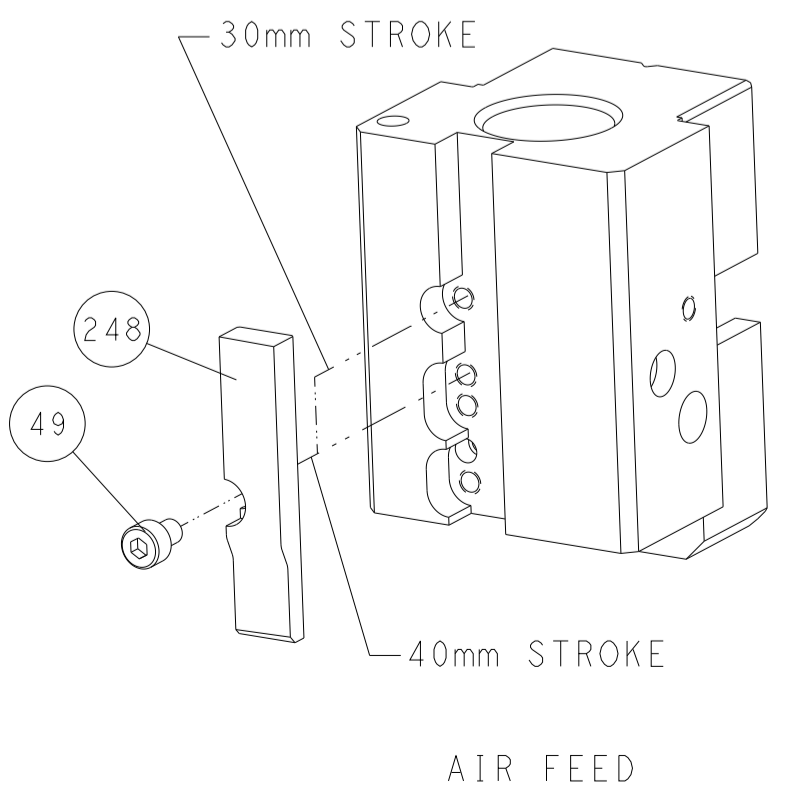

ATLANTIC VERSION  
 Shown on sheets 1 of 4 & 2 of 4  
 (Pacific version shown on sheets 3 of 4 & 4 of 4)

DIMENSIONS:		TOLERANCES UNLESS OTHERWISE SPECIFIED:		REVISIONS	
mm	0 PLC	±		DATE	BY
	1 PLC	±			
	2 PLC	±			
	3 PLC	±			
	4 PLC	±			
	ANGLES	±			
	FINISH	±			
MATERIAL:				NAME	
				Ocean End Feed Applicator	
				SIZE CAGE CODE DRAWING NO	
				A1 00779 C=2150262	
				RESTRICTED TO	
				-	
				CUSTOMER ACCESSIBLE PRODUCTION DRAWING	
				SCALE 1:1 SHEET 2 OF 4 REV C	

8	7	6	5	4	3	2	1
THIS DRAWING IS UNPUBLISHED.		RELEASED FOR PUBLICATION		20			
COPYRIGHT 20 BY TYCO ELECTRONICS CORPORATION. ALL RIGHTS RESERVED.							
PART NUMBER	REVISION	DESCRIPTION	FEED TYPE				
2-2150262-2	C	FINE CRIMP HEIGHT ADJUST	PNEUMATIC				
7-2150262-7	B	CRIMP TOOLING KIT	-				

PACIFIC VERSION TERMINATOR INTERFACE ADAPTER

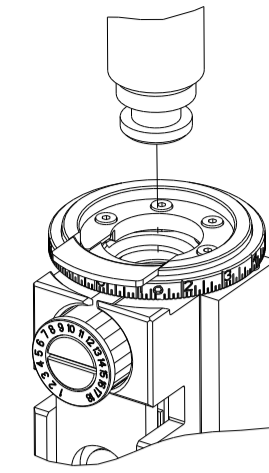

APPLICATOR DATA		
CRIMP	SIZE	TYPE
WIRE	2.79 mm (.110)	F
INSUL	3.94 mm (.155)	F
APPLICATOR INSTRUCTIONS 408-35043		

TERMINAL DATA: TE TERMINAL		TE CRIMP SPECIFICATION	
TERMINAL NAME: RECEPTACLE, CLUSTER PIN AMPLIVAR, .090 DIA, 1600-4800 CMA			
WIRE STRIP LENGTH 6.35-7.11 mm (.250-.280 IN)		INSULATION DIAMETER RANGE Ø1.91-3.18 mm (.075-.125 IN)	
TERMINAL APPLICATION SPECIFICATION	114-2019	8	-
TERMINALS APPLIED 5, 6, 8			
TE TERMINAL	TE TERMINAL	TE TERMINAL	TE TERMINAL
1742964-1	2385525-1		

WIRE SIZE	CRIMP HEIGHT mm [INCH]	CRIMP HEIGHT REFERENCE SETTING
13.5 MAG	1.88 +/- 0.05 [.074 +/- .002]	8.8
15 MAG	1.68 +/- 0.05 [.066 +/- .002]	11.0
18 MAG	1.47 +/- 0.05 [.058 +/- .002]	12.1

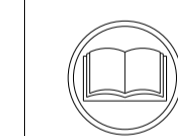

- 1 RECOMMENDED SPARE PARTS.
- 2 REFER TO SUPPLIED INSTRUCTION SHEET FOR CLEANING, LUBRICATION AND STORAGE OF APPLICATOR.
- 3 APPLY PART NUMBER 2-23419-6 LOCTITE TO THREADS OF ITEM 242.
- 4 CRIMP HEIGHT REFERENCE SETTING WAS THE SETTING USED WHEN THE APPLICATOR WAS QUALIFIED AT THE FACTORY. ADJUSTMENT MAY BE NECESSARY WHEN RUNNING APPLICATOR IN THE FIELD.
- 5 TERMINAL PITCH NOT COMPATIBLE WITH MECHANICAL FEED.
- 6 FEED TERMINAL OFF OF RECEPTACLE.
- 7 RECOMMENDED SET-UP WIRE FOR QUALIFICATION ONLY AT THE FACTORY.
- 8 REFER TO APPLICATION SPECIFICATION FOR ADDITIONAL WIRE CRIMP HEIGHTS.
- 9. UNLESS SPECIFIED OTHERWISE TORQUE VALUES SHALL BE USED PER DOCUMENT, 101-35000.

**\*WARNING**  
ON INSTALLATION, SET WIRE DISC TO CRIMP HEIGHT REFERENCE SETTING FOR LARGEST WIRE SIZE. CRIMP HEIGHT REFERENCE SETTINGS GREATER THAN THE VALUE SHOWN MAY CAUSE DAMAGE TO THE CRIMP TOOLING, REFER TO THE INSTRUCTION SHEET FOR PROPER SETUP AND ADJUSTMENTS.

**PACIFIC VERSION**  
Shown on sheets 3 of 4 & 4 of 4  
(Atlantic version shown on sheets 1 of 4 & 2 of 4)

LOC	DIST	REVISIONS					
A	66	P	LTN	DESCRIPTION	DATE	OWN	APVD
		-		SEE SHEET 1	-	-	-

3	-	1	2119082-9	CAM, SNAIL, INSULATION ADJUSTMENT	244	
	-	1	2079764-1	WASHER, WAVE SPRING, CREST-TO-CREST	243	
	-	1	2119083-1	RETAINER, INSULATION DIAL	242	
	-	1	2844940-3	AIR FEED MODULE	238	
	-	1	1-18028-0	WASHER, FLAT, REG M8	192	
	-	4	2079383-9	SCR, BHSC, RoHS (M6 X 20)	186	
	REF		994970-2	COUNTER, MAGNETIC	164	
	-	1	2119641-2	FEED CAM, AIR FEED	152	
	-	1	2168083-8	SCR, SKT HD CAP, RoHS, M4 X 16	144	
	-	1	2119655-6	APPLICATOR BASIC ASSEMBLY, EF	141	
	-	1	1803518-1	RAM ASSEMBLY, EF PACIFIC	140	
	-	1	455888-7	SPACER, CRIMPER	82	
	-	1	1803607-4	DOCUMENTATION PACKAGE	71	
	-	2	2-18032-2	SCR, SET, FLT PNT, M3 X 10.0	70	
	-	1	2119740-1	TAG, IDENTIFICATION	67	
	-	2	2168078-1	SCREW, DRIVE, RH, RoHS, 2 x .188	66	
	-	1	5-18022-5	SCR, HEX HD CAP, M4 X 6.0	59	
	-	4	2168400-4	SHCS, LOW HEAD, RoHS, M4 X 8	57	
	-	2	1-2168083-0	SCR, SKT HD CAP, RoHS, M4 X 10	56	
	-	2	5018030-1	NUT, HEX, REG, RoHS, M3	54	
	-	2	986965-8	NUT, LOCK, HEX, TORQUE (M4)	53	
	6	-	1	2063961-1	FEED FINGER	51
	-	1	18023-9	SCR, SKT HD CAP M4 X 6.0	49	
	-	1	1803602-2	SCR, BHSC, RoHS (M8 X 40)	41	
	-	8	1-18028-2	WASHER, FLAT, REG M4	33	
	-	2	2168083-9	SCR, SKT HD CAP, RoHS, M4 X 20	31	
	-	2	2168083-2	SCR, SKT HD CAP, RoHS, M4 X 8.0	29	
	-	1	240639-1	STRIPPER (MACHINING)	27	
	-	2	1-2168083-5	SCR, SKT HD CAP, RoHS, M4 X 30	25	
	-	1	1752371-5	PLATE, STRIP GUIDE	24	
	-	2	2-22281-3	SPRING, COMPRESSION	22	
	-	1	1803292-1	DRAG	20	
	-	2	1901259-3	GUIDE, LOWER STRIP	18	
	-	1	217573-3	TOOL, SIZING	15	
	-	1	1752360-1	SPACER, HOLD-DOWN	13	
	-	1	240644-1	PLATE, REAR SHEAR	11	
	-	-	-	-	10	
	1	-	1	690482-3	PLATE, FRONT SHEAR	9
	1	1	819517-4	ANVIL, COMBINATION	8	
	1	-	1	1-2217206-3	BLADE, SLUG	7
	-	1	4-240641-8	SPACER	5	
	-	1	238011-2	BLOCK, CRIMPER SPACER	4	
	1	1	3-2119582-6	CRIMPER, INSULATION F PREMIUM	3	
	-	1	455888-3	SPACER, CRIMPER	2	
	1	1	819516-8	CRIMPER, WIRE	1	

DIMENSIONS:		TOLERANCES UNLESS OTHERWISE SPECIFIED:		DWG		21JUN2012		TE Connectivity	
mm		0 PLC ±		CHK		Y. YIN		Harrisburg, PA 17105-3608	
Ø		1 PLC ±		G. BAILEY		21JUN2012		Ocean End Feed	
H		2 PLC ±		APVD		S. XI		Applicator	
D		3 PLC ±		PRODUCT SPEC		21JUN2012		-	
R		4 PLC ±		APPLICATION SPEC		-		-	
A		5 PLC ±		SIZE		A1		00779	
C		6 PLC ±		CAGE CODE		-		2150262	
E		7 PLC ±		DRAWING NO		-		-	
F		8 PLC ±		RESTRICTED TO		-		-	
G		9 PLC ±		WEIGHT		-		-	
H		10 PLC ±		CUSTOMER ACCESSIBLE PRODUCTION DRAWING		SCALE		1:1	
J		11 PLC ±		SCALE		1:1		SHEET 3 OF 4	
K		12 PLC ±		SCALE		1:1		REV C	
L		13 PLC ±		SCALE		1:1		REV C	

LOC	DIST	REVISIONS			
P	LTN	DESCRIPTION	DATE	DMN	APVD
A	66	SEE SHEET 1			

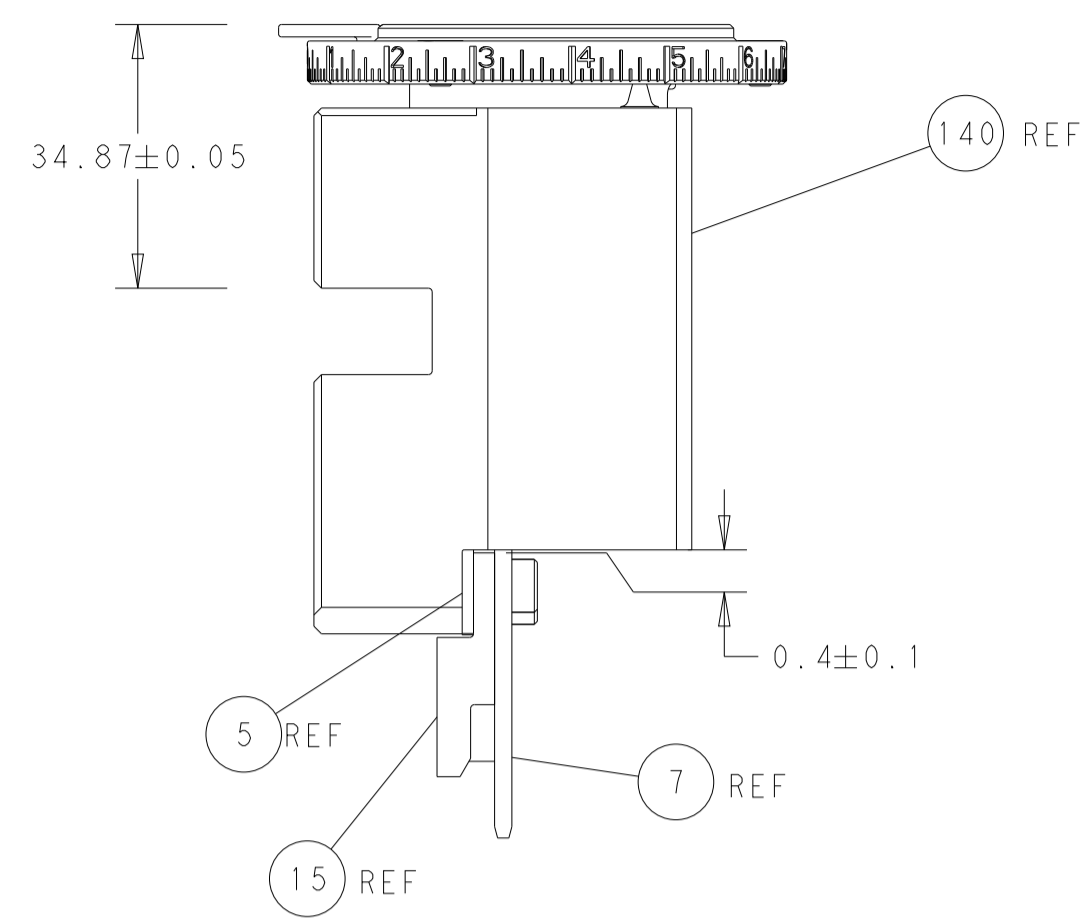

RAM AND HOLDDOWN SET-UP

FEED TYPE

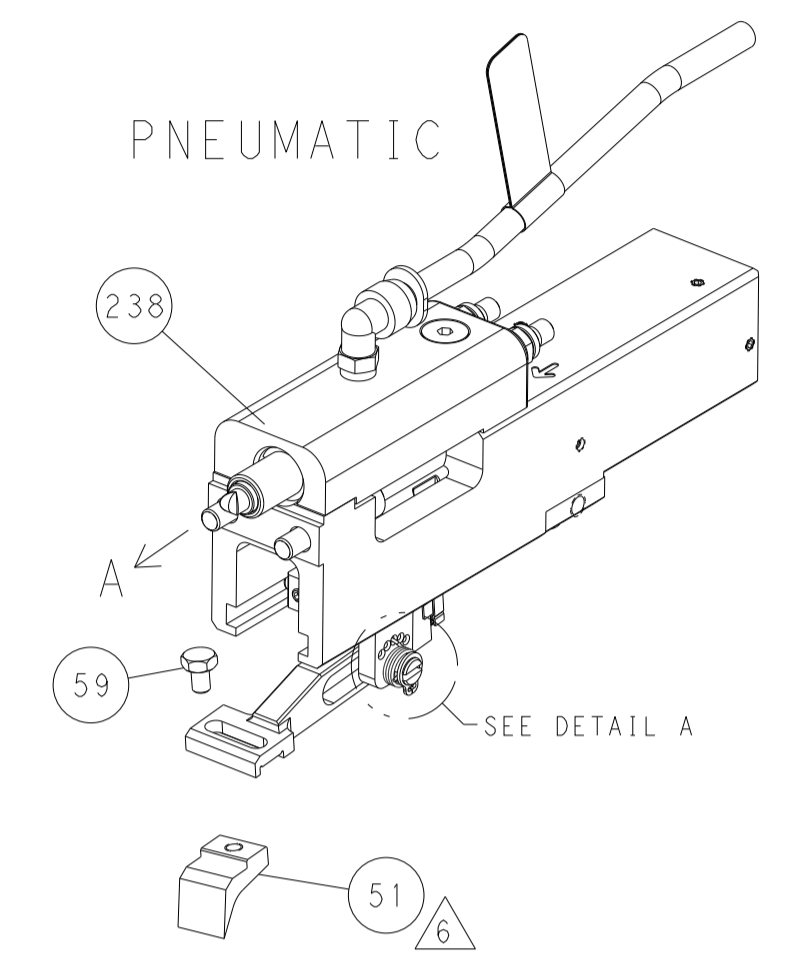

FEED SPRING SETTING POSITION

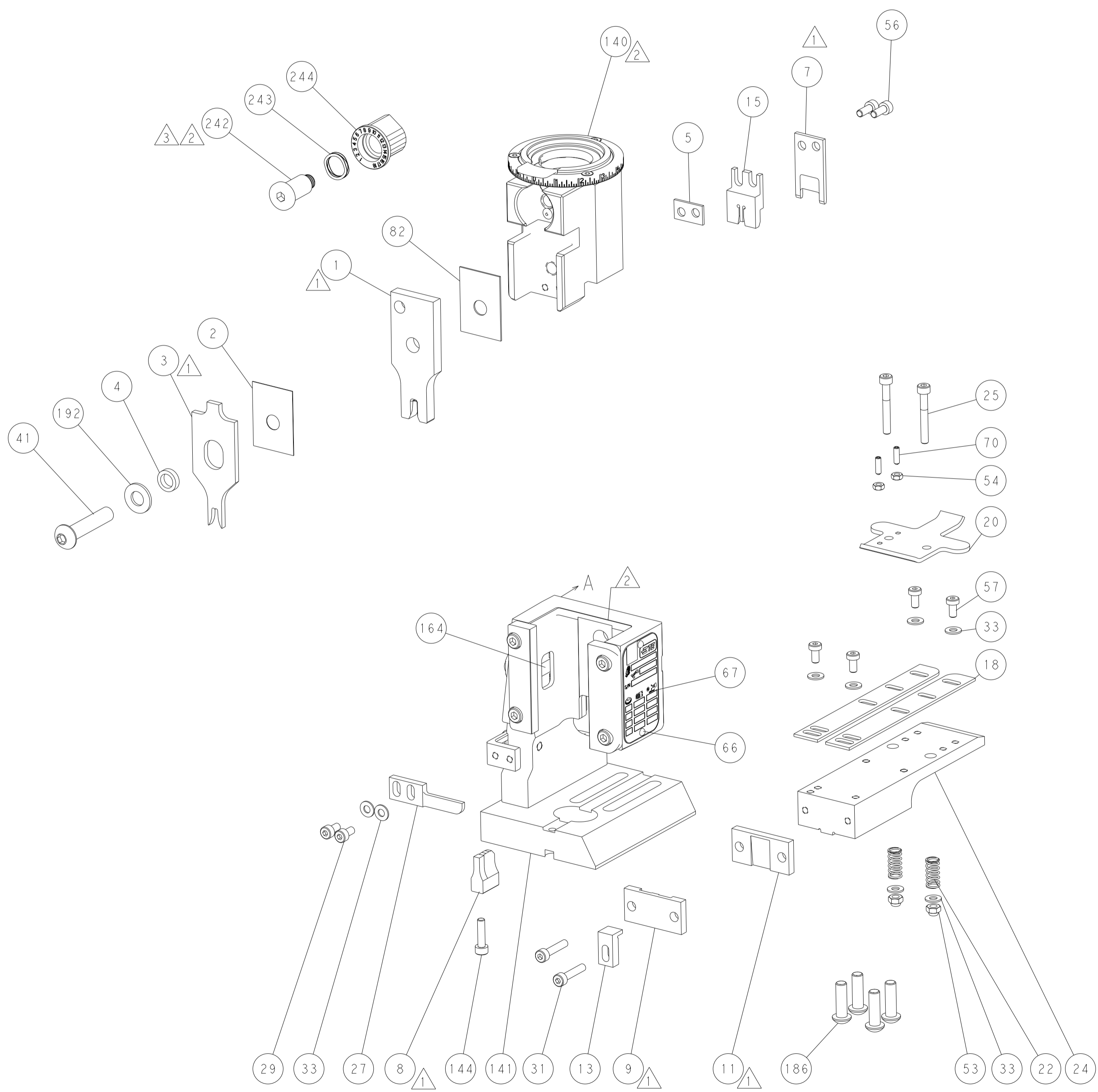
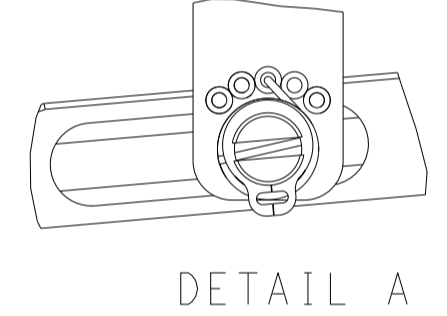

CAM POSITION

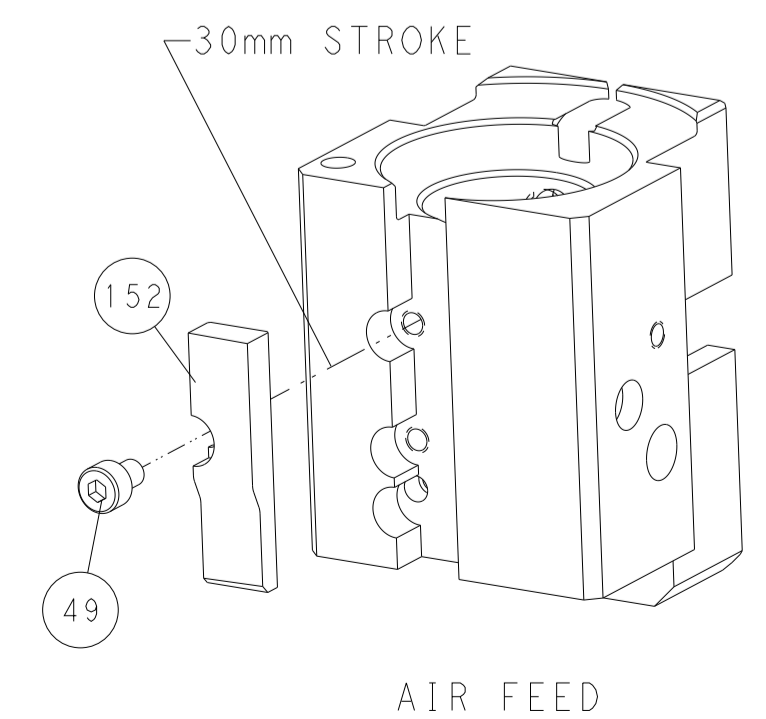

PACIFIC VERSION  
 Shown on sheets 3 of 4 & 4 of 4  
 (Atlantic version shown on sheets 1 of 4 & 2 of 4)

<small>THIS DRAWING IS UNPUBLISHED. RELEASED FOR PUBLICATION. ALL RIGHTS RESERVED. © 2012 BY TYCO ELECTRONICS CORPORATION. THIS DRAWING IS UNPUBLISHED. RELEASED FOR PUBLICATION. ALL RIGHTS RESERVED. © 2012 BY TYCO ELECTRONICS CORPORATION. THIS DRAWING IS UNPUBLISHED. RELEASED FOR PUBLICATION. ALL RIGHTS RESERVED. © 2012 BY TYCO ELECTRONICS CORPORATION.</small>		DWN: Y. YIN 21JUN2012 CHK: G. BAILEY 21JUN2012 APVD: S. XI 21JUN2012	NAME: Ocean End Feed Applicator SIZE: A1 CAGE CODE: 00779 DRAWING NO: C-2150262 SCALE: 1:1 SHEET: 4 OF 4 REV: C
DIMENSIONS: mm TOLERANCES UNLESS OTHERWISE SPECIFIED: 0 PLC ± 1 PLC ± 2 PLC ± 3 PLC ± 4 PLC ± ANGLES ± FINISH ±	MATERIAL:	RESTRICTED TO:	CUSTOMER ACCESSIBLE PRODUCTION DRAWING