

FPC401 and FPC402 Evaluation Module (EVM) User's Guide

The information and/or drawings set forth in this document and all rights in and to inventions disclosed herein and patents which might be granted thereon disclosing or employing the materials, methods, techniques, or apparatus described herein are the exclusive property of Texas Instruments. No disclosure of information or drawings shall be made to any other person or organization without the prior consent of Texas Instruments.

Contents

1	Hardware Description and Setup	2
1.1	Power Configuration	2
1.2	Communication Protocol Configuration	3
2	FPC401 EVM GUI Description and Setup	5
2.1	Installation	6
2.2	Initializing Communication	6
2.3	Local FPC Read and Write	8
2.4	Remote Access on Downstream Modules	9
2.5	Input and Output Status and Configuration	10
2.6	Interrupt Configuration and Monitoring	11
2.7	LED Configuration	12
2.8	Prefetch Configuration	13
2.9	Data-Driven Interrupt Configuration	14
2.10	Scheduled Write Configuration	15

Trademarks

All trademarks are the property of their respective owners.

1 Hardware Description and Setup

The general procedure for setting up the FPC401 and FPC402 Evaluation Modules (EVM) is described in the following sections.

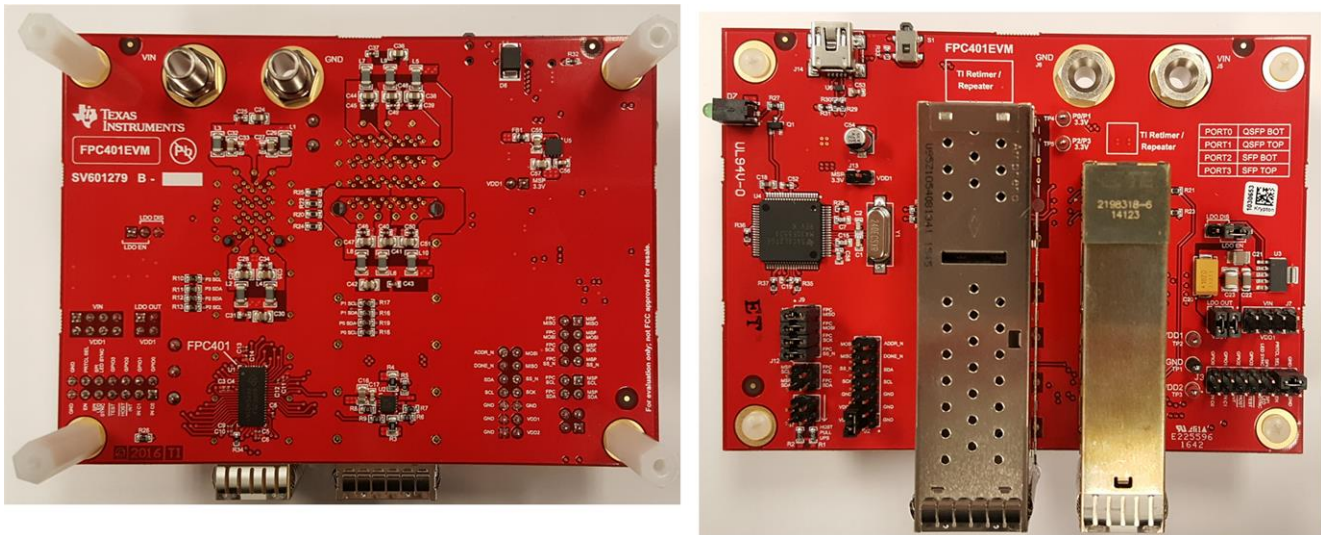
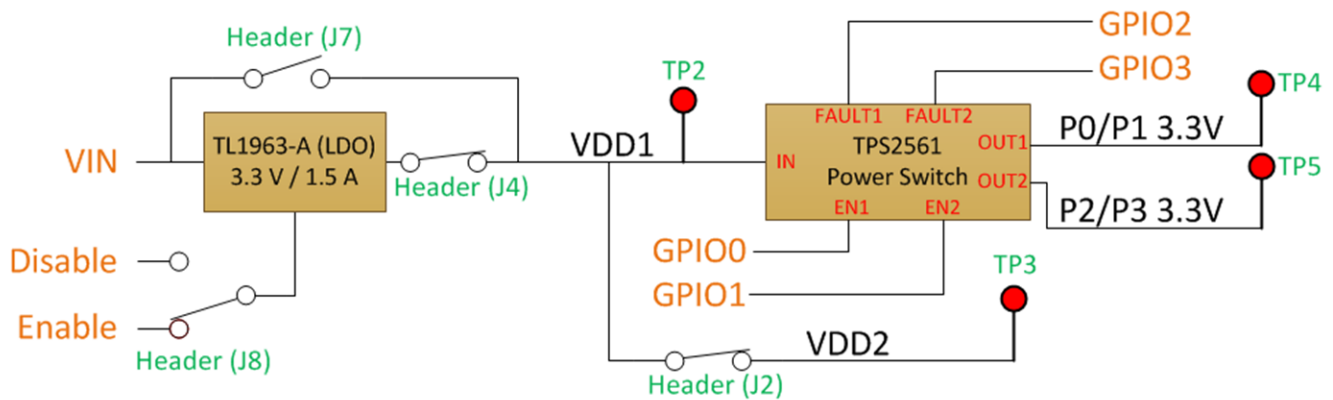

Figure 1. FPC40xEVM – Top and Bottom

1.1 Power Configuration

Configure the power illustrated by [Figure 2](#).

1. If the LDO is used to power the FPC, enable the LDO through header J8 and connect the LDO output to VDD1 using header J4 (note that each header connection is rated for 1 A of current). Make sure headers J7 and J13 are disconnected. The LDO has a maximum rated current of 1.5 A, so if the cumulative QSFP/SFP module current draw is greater than that, the LDO may not be used.
2. If the LDO is not used and the FPC is powered through an external supply, configure the J8 header to disable the LDO and connect VIN to VDD1 using header J7 (note that each header connection is rated for 1 A of current). Make sure headers J4 and J13 are disconnected.
3. If USB power is used to power the FPC, ensure the LDO and VIN are disconnected from VDD1 (disconnect headers J4 and J7). Connect the 3.3 V of the MSP430 microcontroller to VDD1 through header J13. Note that a typical computer USB port is only able to supply up to 100 mA which will be enough to power the FPC and passive modules (that is, DAC); but it will not be enough to power active SFP+ and QSFP+ modules which are plugged in.
4. To set VDD2 to 3.3 V, connect it to VDD1 through header J2. To operate at lower host-side supply voltages (down to 1.8 V), connect an external supply to the header or test point loop (TP3).
5. The FPC401EVM and FPC402EVM includes a TPS2561 power switch which is used to selectively enable and disable 3.3-V power to the SFP and QSFP ports. The FPC controls this power switch with its GPIO pins. To supply power to ports 0 and 1 (QSFP+ ports and LEDs), configure the FPC GPIO0 high logic output to enable the power switch. Similarly, configure GPIO1 to high logic to enable power for ports 2 and 3 (SFP+ ports and LEDs). Alternatively, supply 3.3 V externally through the test points (TP4 and TP5). Note that the ground is shared with the board.
6. GPIO2 and GPIO3 are connected to the fault outputs of the power switch, and hence should be set as inputs or left unconfigured.



Copyright © 2016, Texas Instruments Incorporated

Figure 2. Power Block Diagram – Configured for LDO Use

1.2 Communication Protocol Configuration

The following sections describe how to configure the FPC401EVM and FPC402EVM for I2C and SPI protocols.

1.2.1 I2C Configuration

For I2C communication with the onboard MSP430, refer to [Figure 3](#) and configure the board based on the following procedure.

1. Leave the PRTCL_SEL pin disconnected (header J3).
2. Connect the MSP430 SCL and SDA to the FPC SCL and SDA through header J12. The SPI header (J9) should be disconnected.
3. Connect the 2.7-k Ω pullup resistors through header J1.
4. Connect the VDD2 pin to the VDD1 pin through header J2.
5. Connect the ADDR_N pin to GND through header J2 with the provided jumper wire.

For I2C communication with an external host controller, disconnect the MSP430 SDA and SCL. Connect the FPC SDA and SCL pins to the SDA and SCL pins of the host controller. Only connect the onboard pullup resistors if the host board does not have pullups.

To control multiple EVMs, connect all the SDA and SCL pins together. Only one board should have the MSP430 and pullup resistors connected to these pins. The ADDR_N of the first device should be tied to GND as shown in [Figure 3](#). Connect DONE_N pin of the first device to the ADDR_N of the second device, and the DONE_N pin of that device to the following device in a daisy-chained fashion until all ADDR_N pins are connected. Connect the final DONE_N pin to GND. See the data sheet for more details on how I2C is configured.

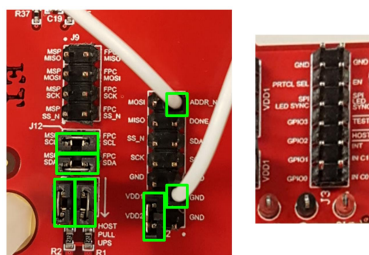

Figure 3. I2C Configuration

1.2.2 SPI Configuration

For SPI communication with the onboard MSP430, refer to [Figure 4](#) and configure the board based on the following procedure.

1. Connect the PRTCL_SEL pin to GND through header J3.
2. Connect the MSP430 MISO, MOSI, SCK, and SS_N pins to the FPC MISO, MOSI, SCK, and SS_N pins through header J9. The I2C header (J12) should be disconnected.
3. Connect the VDD2 pin to the VDD1 pin through header J2.

For SPI communication with an external host controller, disconnect the MSP430 MOSI, MISO, SCK, and SS_N pins. Connect the FPC MOSI, MISO, SCK, and SS_N pins to the MOSI, MISO, SCK, and SS_N pins of the host controller.

To control multiple EVMs with SPI, connect all the SCK and SS_N pins to a single MSP430 SCK and SS_N pins. Daisy chain the MOSI and MISO pins so that the MOSI of the MSP430 connects to the MOSI of the first device, the MISO of the first device connects to the MOSI of the second device, and so on, until the final device's MISO connects to the MISO of the MSP430. See the data sheet for more details on how SPI is configured.

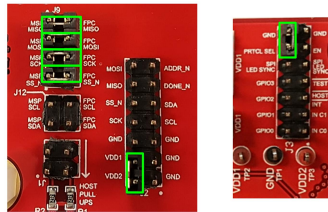

Figure 4. SPI Configuration

2 FPC401 EVM GUI Description and Setup

The FPC401 EVM GUI is used to program both FPC401EVM and FPC402EVM. The general procedure for setting up the FPC401 GUI is described in the sections below.

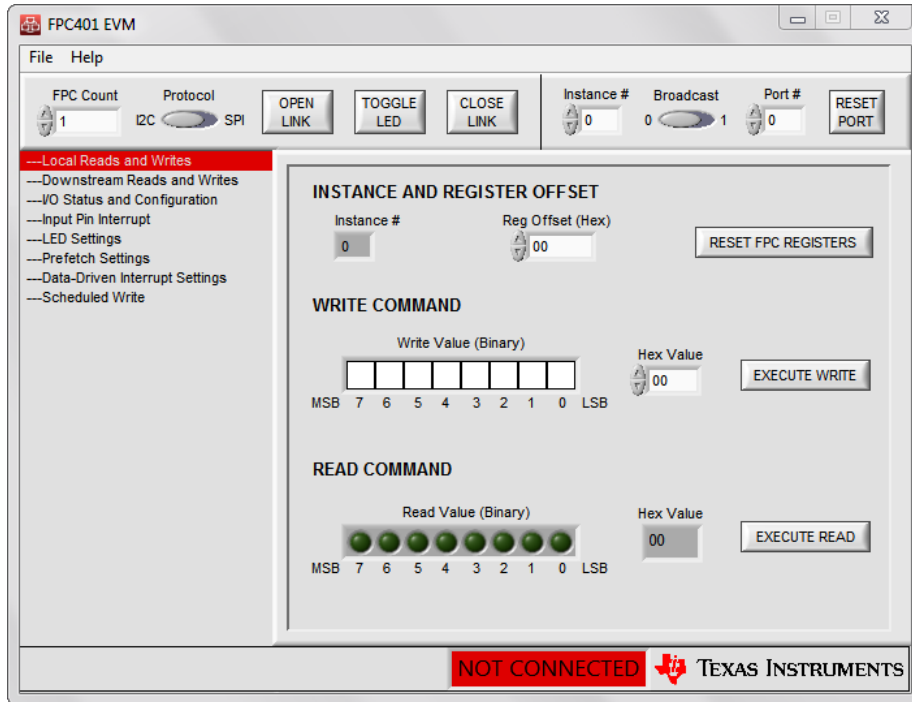

Figure 5. FPC401 EVM GUI

2.1 Installation

The FPC401 EVM GUI has two installers. The *Setup_FPC401_EVM.exe* installer does not contain the *National Instruments Run-Time Engine* and requires web access to download the NI run-time engine if the computer does not already have this installed. The *Setup_FPC401_EVM_with_RTE.exe* installer is a larger file that contains the run-time engine and does not require web access. Select the appropriate installer and follow the installer wizard to install the FPC401 EVM GUI.

2.2 Initializing Communication

To initialize communication with the FPC401EVM, first select the number of FPC401s under *FPC Count* and the protocol (I2C or SPI), highlighted by [Figure 6](#). Click *OPEN LINK* to establish communication with the MSP430 through USB and initialize the device. In I2C mode, this will configure the MSP430 and automatically configure the I2C addresses of all connected FPC401s so that each one has a unique address. In SPI mode, this will configure the MSP430 and establish the length of the SPI message. Each time the hardware configuration changes, the link must be reestablished. For example, connecting additional FPC401s or changing the communication from I2C to SPI requires the link to be reestablished.

The *TOGGLE LED* button will toggle the LED (D7) for a visual indication that the USB communication is working. The text in the bottom of the GUI should say *CONNECTED* and turn green after USB communication is established. Note that this means that the computer is communication with the MSP430 but does not necessarily mean that communication is established with the FPC401.

The *CLOSE LINK* button will terminate USB communication.

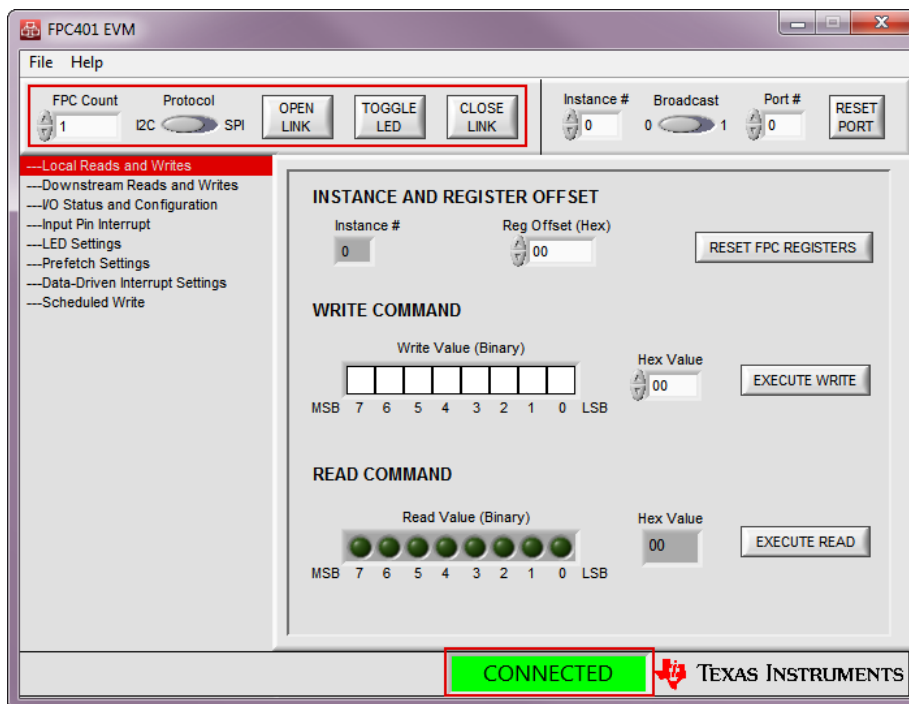

Figure 6. Communication Control

The top right section of the GUI highlighted by [Figure 7](#) controls the FPC(s) being programmed by all controls in this GUI. The *Instance #* selects which FPC is being controlled, starting at instance 0. The *Port #* selects which port is being configured, where 0 is the port 0 of FPC instance 0, and 4 is port 0 of FPC instance 1. The *Broadcast* switch will broadcast commands to all FPCs if set to 1. Note that if a command that targets a port is broadcasted, not all ports will be modified. Instead, only ports that match the local port of the selected instance are modified. For example, broadcasting a command that targets port 5 (local port 1 of instance 1) will affect ports 1, 5, 9, 13, and so forth.

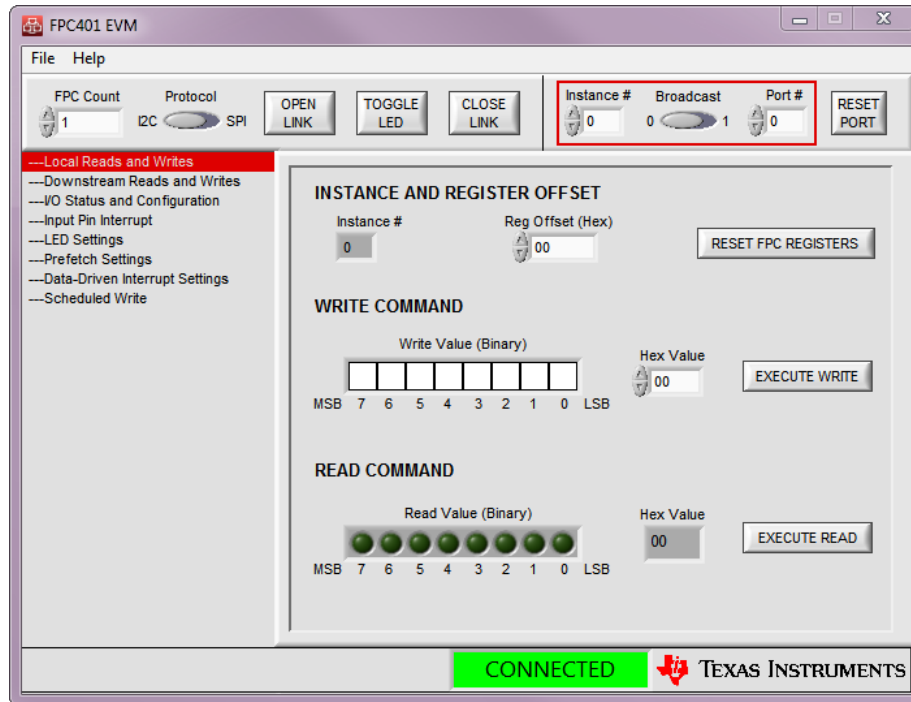

Figure 7. FPC Instance and Port Selection

2.3 Local FPC Read and Write

To read and write to local FPC registers, select the *Local Reads and Writes* tab. Select the instance number and register offset address to be read or written to. To write, select a value using the radio boxes in the *WRITE COMMAND* section or type the desired hex value and click *EXECUTE WRITE*. To read, click *EXECUTE READ*. The *RESET FPC REGISTERS* button will reset the instance's local FPC registers. Note that performing a register reset in I2C mode will restore the default I2C address of the device and the link must be closed and reopened to restore normal GUI operation.

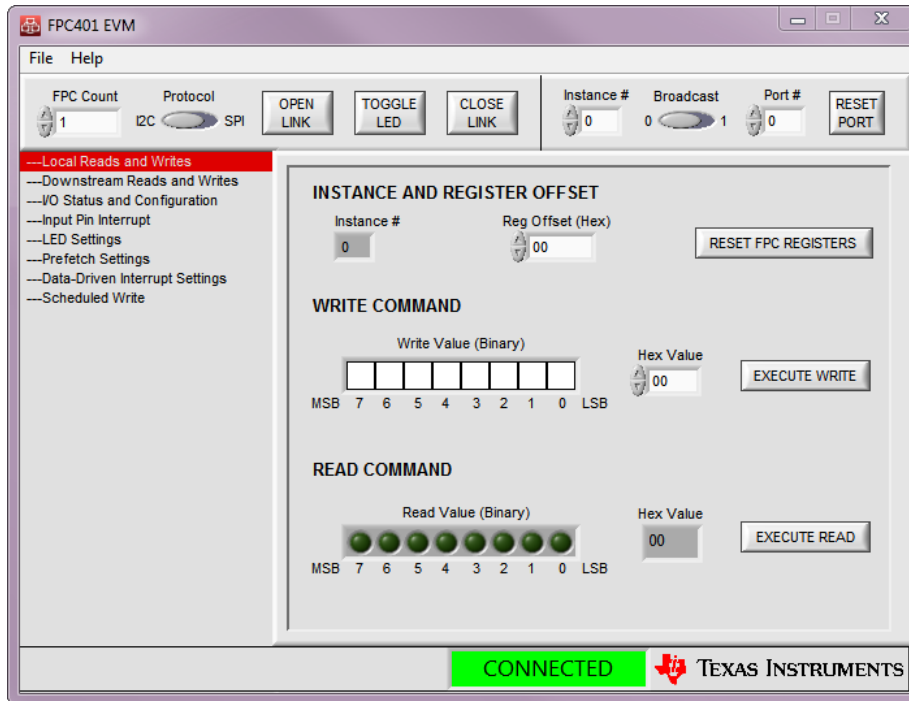

Figure 8. FPC401 GUI – Local Reads and Writes

2.4 Remote Access on Downstream Modules

To perform a remote access read or write on a downstream port, select the *Downstream Reads and Writes* tab. Select the port number, downstream device I2C address, and register offset address. To write, select a value using the radio boxes in the *WRITE COMMAND* section or type the desired hex value and click *EXECUTE WRITE*. To read, click *EXECUTE READ*. The *Set I2C Rate* switch will toggle the I2C rate of the downstream between 100 kHz (SFP) and 400 kHz (QSFP).

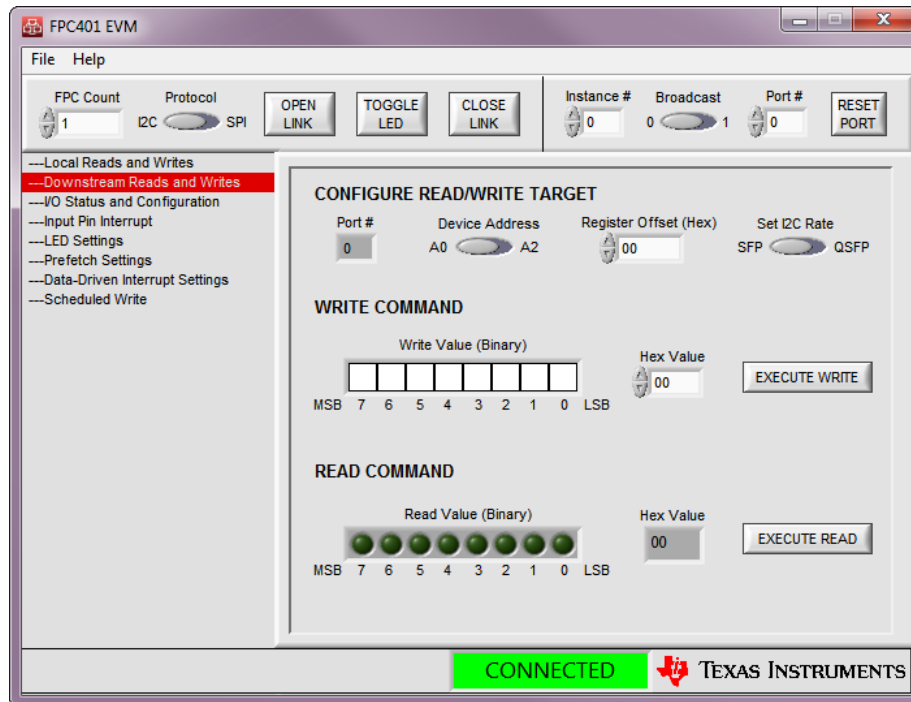

Figure 9. FPC401 GUI – Downstream Reads and Writes

2.5 Input and Output Status and Configuration

To control the input, output, and GPIO pins, select the *I/O Status and Configuration* tab. The *Enable Periodic Update* button will update the indicator of each input, GPIO, and output periodically set by the *Update Period (ms)* slider. This will also update the *Port's Aggregated Interrupt Flag* which determines if any interrupt of the selected port has been triggered. To modify the state of the GPIOs, modify the *GPIO 0/1/2/3 Set* drop-down menus and click *SET GPIOs*. To modify the state of the outputs, modify the *OUT A/B Set* drop-down menus and click *SET OUTPUTS*.

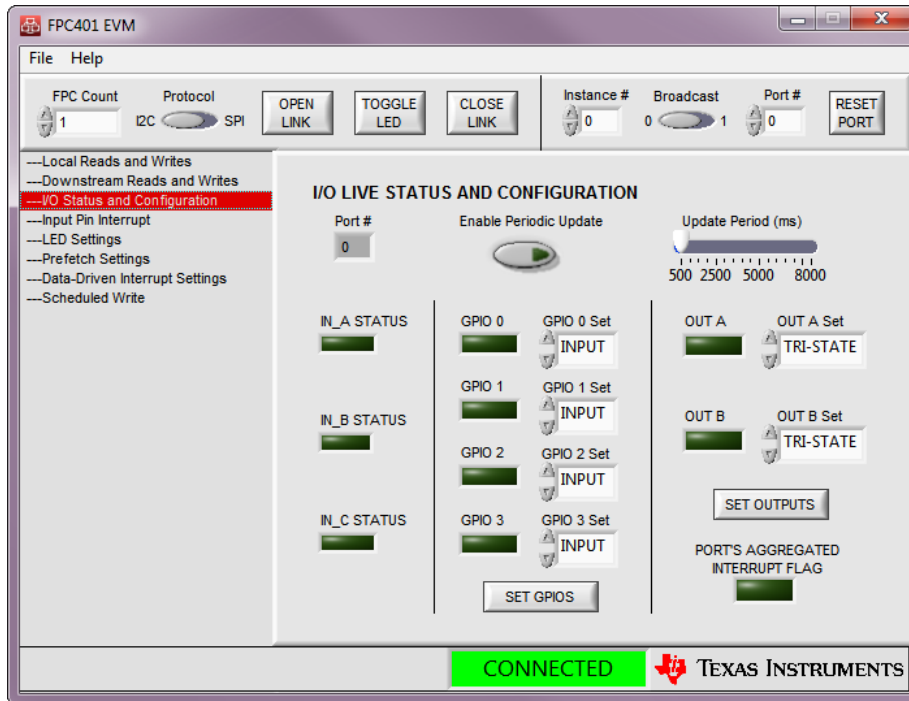

Figure 10. FPC401 GUI – Input, Output, GPIO Status, and Control

2.6 Interrupt Configuration and Monitoring

To configure the port's interrupts, select the *Input Pin Interrupt* tab. To enable input pin interrupts, select the port, input trigger source, and trigger edge. Click *SET* to configure. To check and clear the status of all of the interrupts of the selected port, click *UPDATE AND CLEAR*. Some of these interrupts are configured in other sections.

To enable the SDA and SCL instances stuck at 0 interrupts, click *SDA STUCK ENABLE* and *SCL STUCK ENABLE* buttons. These buttons enables the interrupts for all ports of the selected instance. To clear these interrupts, a port reset must be issued using the *RESET PORT* button, highlighted in [Figure 12](#).

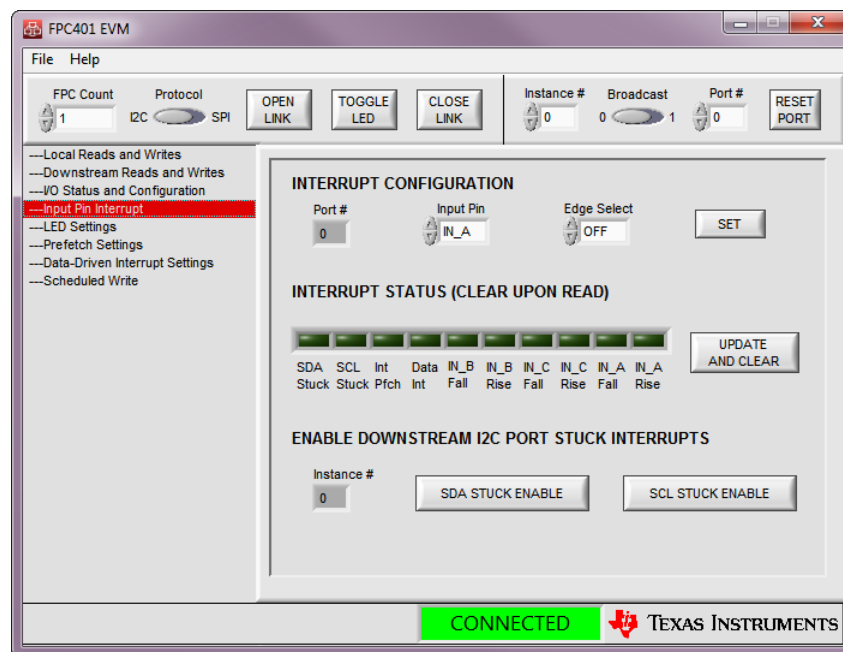

Figure 11. FPC401 GUI – Interrupt Control

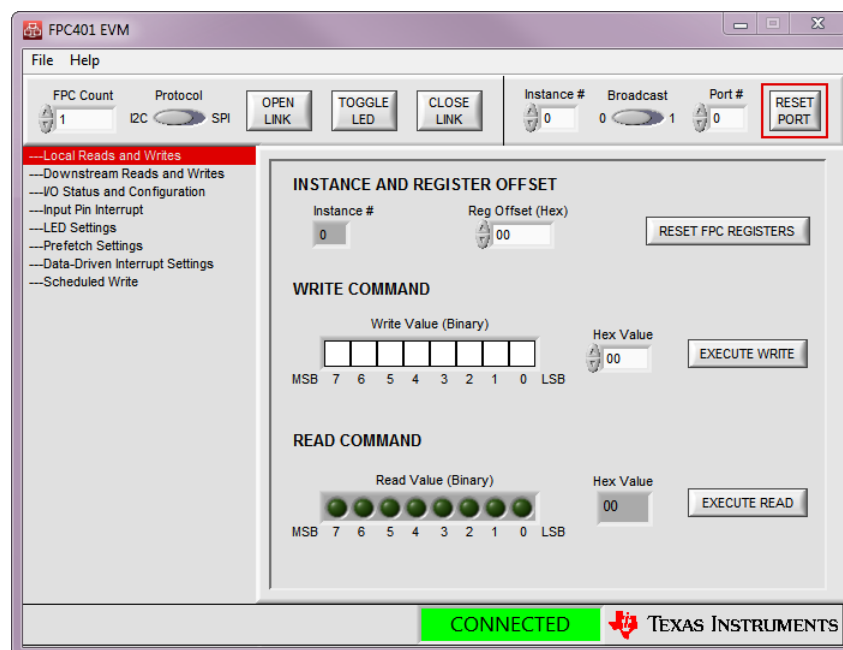

Figure 12. FPC401 GUI – Port Reset

2.7 LED Configuration

To configure the LEDs, select the *LED Settings* tab. Select the port number, LED number, LED state and click the *SET* button in the *LED STATE* section. If configured in the *PWM* or *BLINK* mode, use the *Duty Cycle (%)* slider and click *SET* in the *PWM MODE SETTINGS* section. Since the PWM duty cycle is 0 by default, the LEDs will not be visible until this is modified. In *BLINK* mode, configure the *On Time* and *Off Time* and click *SET* under the *BLINK MODE SETTINGS* section. To synchronize the LEDs, click the *SYNCHRONIZE LEDS* button at the bottom of the page. This will automatically forward the LED clock for synchronization across multiple devices. See the data sheet for more details.

Note that in the FPC401EVM and FPC402EVM the GPIO0 and GPIO1 must be set to drive high logic to enable the power switch that powers the LEDs and modules.

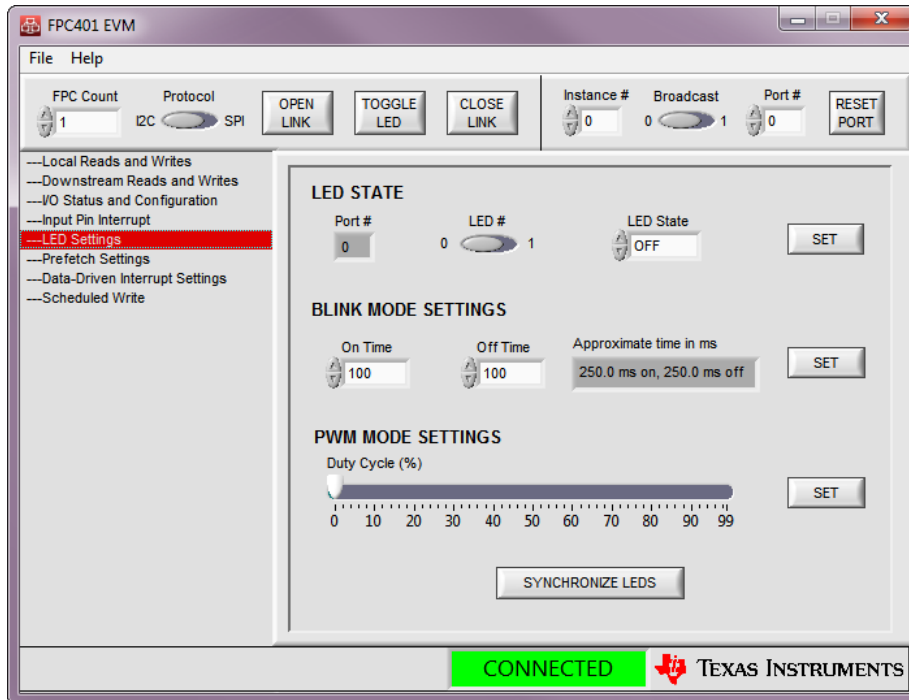

Figure 13. FPC401 GUI – LED Settings

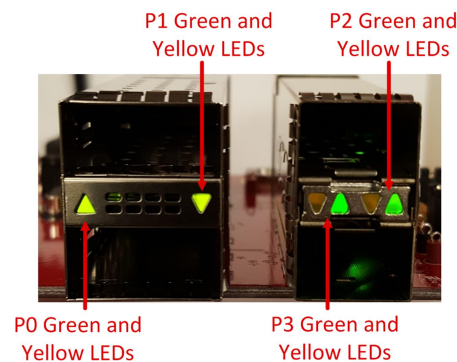

Figure 14. LED Mapping

2.8 Prefetch Configuration

To configure prefetching, select the *Prefetch Settings* tab. The **PREFETCH GLOBAL SETTINGS** determines the port number, device I2C address (0xA0 or 0xA2), prefetch length, and starting register offset address for both the periodic prefetch and interrupt-driven prefetch features. The *Prefetch Length* input controls the number of bytes to be prefetched and the *Prefetch Offset (Hex)* input determines the starting register offset address.

In the **PERIODIC PREFETCH SETTINGS** section, enter the prefetch period in milliseconds and click **START PREFETCH**. A period of 0 ms is a one-time prefetch. To stop the periodic prefetch, click the **STOP PREFETCH** button. This will not clear the gate bit, so any downstream read in the prefetched range will read from the FPC memory. To reset the gate bit and force the FPC to read from the downstream port, click **RESET GATE**. See the data sheet and programmer's guide for more details about prefetching.

In the **INTERRUPT DRIVEN PREFETCH** section, select the input that will trigger the interrupt-driven prefetch, the edge transition of the selected input, and click **SET**. After an interrupt-driven prefetch is successful, to clear the gate bit and perform another one, click the **RE-ARM** button. This will also clear the interrupt.

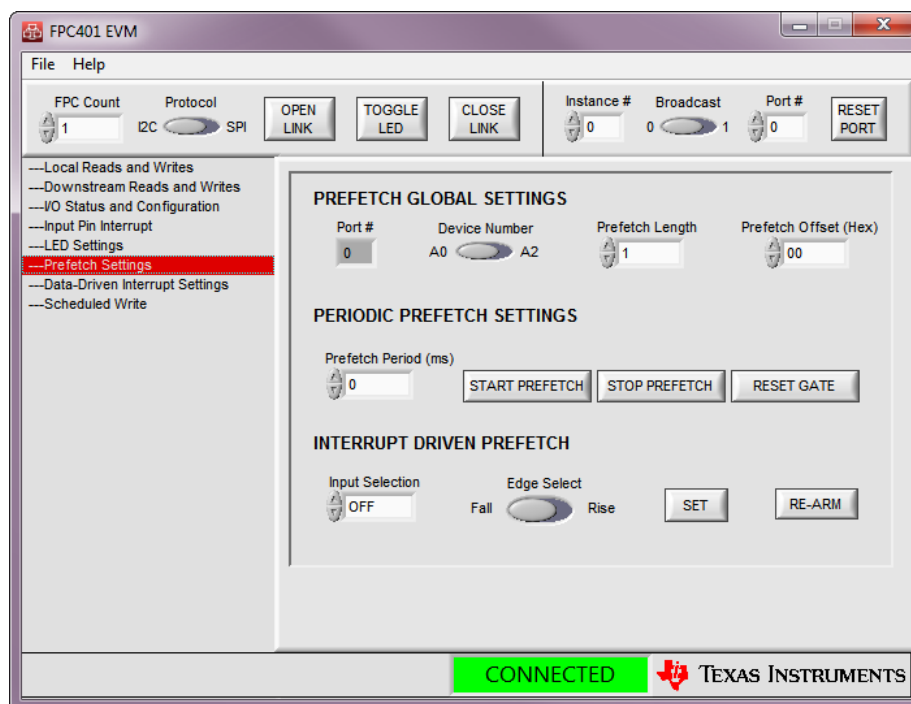

Figure 15. FPC401 GUI – Prefetch Settings

2.9 Data-Driven Interrupt Configuration

To configure data-driven interrupts, select the *Data-Driven Interrupt Settings* tab. The FPC is able to monitor up to four bytes per port, and the monitored byte index is controlled by the *Byte Number* input. Select the port number, register address to be monitored and the bits to be monitored and click *SET*. Note that the monitored register address must be within the prefetched range for the selected port. Click *CHECK / CLEAR DATA* to determine which bits of the four monitored bytes triggered the interrupt. This will also clear the interrupt.

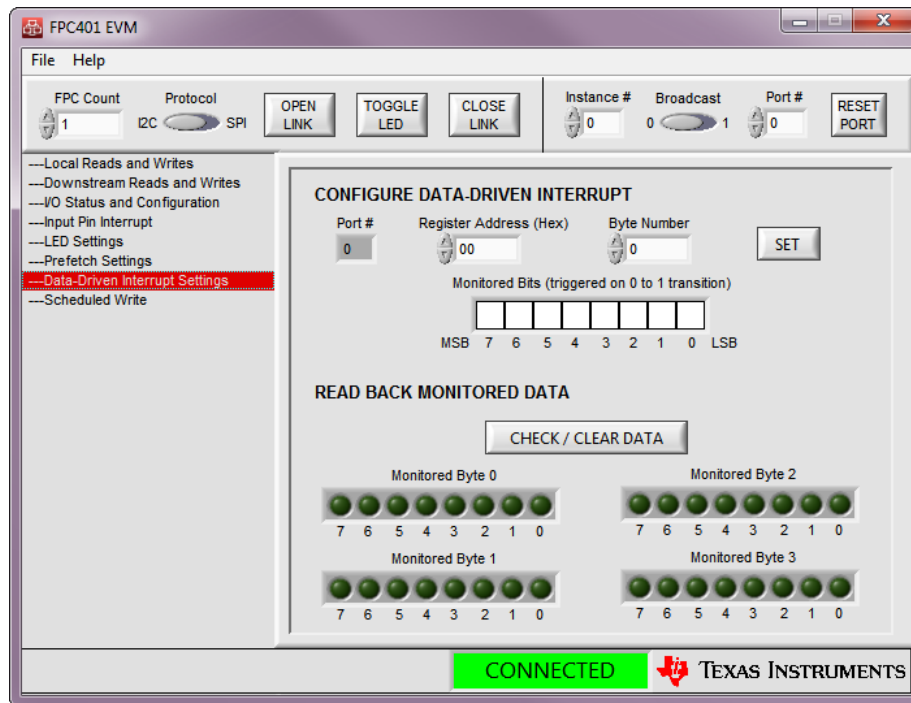

Figure 16. FPC401 GUI – Data-Driven Interrupt Control

2.10 Scheduled Write Configuration

To perform a scheduled write to one or more downstream ports, select the *Scheduled Write* tab. Select the port number, device address, register offset address, and write value and click *EXECUTE SCHEDULED WRITE*. This will issue a write to the selected port, and may be broadcasted to write to multiple ports across multiple FPC instances. The *CONFIGURE COMMON SCHEDULED WRITE* section works similarly, but the user may also select which of the ports to be written, allowing writing to all four local ports simultaneously.

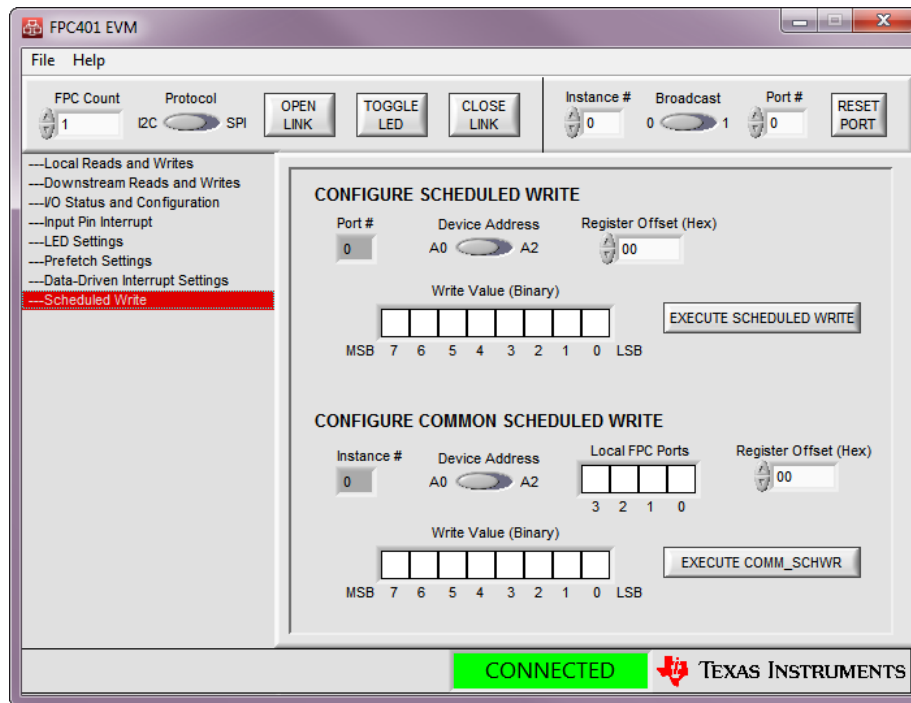

Figure 17. FPC401 GUI – Scheduled Write Control

Revision History

NOTE: Page numbers for previous revisions may differ from page numbers in the current version.

Changes from Original (November 2016) to B Revision	Page
• First public release.	2

Changes from Original (November 2016) to B Revision**Page**

- First public release. **2**
-

STANDARD TERMS FOR EVALUATION MODULES

1. *Delivery:* TI delivers TI evaluation boards, kits, or modules, including any accompanying demonstration software, components, and/or documentation which may be provided together or separately (collectively, an "EVM" or "EVMs") to the User ("User") in accordance with the terms set forth herein. User's acceptance of the EVM is expressly subject to the following terms.
 - 1.1 EVMs are intended solely for product or software developers for use in a research and development setting to facilitate feasibility evaluation, experimentation, or scientific analysis of TI semiconductors products. EVMs have no direct function and are not finished products. EVMs shall not be directly or indirectly assembled as a part or subassembly in any finished product. For clarification, any software or software tools provided with the EVM ("Software") shall not be subject to the terms and conditions set forth herein but rather shall be subject to the applicable terms that accompany such Software
 - 1.2 EVMs are not intended for consumer or household use. EVMs may not be sold, sublicensed, leased, rented, loaned, assigned, or otherwise distributed for commercial purposes by Users, in whole or in part, or used in any finished product or production system.
2. *Limited Warranty and Related Remedies/Disclaimers:*
 - 2.1 These terms do not apply to Software. The warranty, if any, for Software is covered in the applicable Software License Agreement.
 - 2.2 TI warrants that the TI EVM will conform to TI's published specifications for ninety (90) days after the date TI delivers such EVM to User. Notwithstanding the foregoing, TI shall not be liable for a nonconforming EVM if (a) the nonconformity was caused by neglect, misuse or mistreatment by an entity other than TI, including improper installation or testing, or for any EVMs that have been altered or modified in any way by an entity other than TI, (b) the nonconformity resulted from User's design, specifications or instructions for such EVMs or improper system design, or (c) User has not paid on time. Testing and other quality control techniques are used to the extent TI deems necessary. TI does not test all parameters of each EVM. User's claims against TI under this Section 2 are void if User fails to notify TI of any apparent defects in the EVMs within ten (10) business days after delivery, or of any hidden defects with ten (10) business days after the defect has been detected.
 - 2.3 TI's sole liability shall be at its option to repair or replace EVMs that fail to conform to the warranty set forth above, or credit User's account for such EVM. TI's liability under this warranty shall be limited to EVMs that are returned during the warranty period to the address designated by TI and that are determined by TI not to conform to such warranty. If TI elects to repair or replace such EVM, TI shall have a reasonable time to repair such EVM or provide replacements. Repaired EVMs shall be warranted for the remainder of the original warranty period. Replaced EVMs shall be warranted for a new full ninety (90) day warranty period.

WARNING

Evaluation Kits are intended solely for use by technically qualified, professional electronics experts who are familiar with the dangers and application risks associated with handling electrical mechanical components, systems, and subsystems.

User shall operate the Evaluation Kit within TI's recommended guidelines and any applicable legal or environmental requirements as well as reasonable and customary safeguards. Failure to set up and/or operate the Evaluation Kit within TI's recommended guidelines may result in personal injury or death or property damage. Proper set up entails following TI's instructions for electrical ratings of interface circuits such as input, output and electrical loads.

NOTE:

EXPOSURE TO ELECTROSTATIC DISCHARGE (ESD) MAY CAUSE DEGRADATION OR FAILURE OF THE EVALUATION KIT; TI RECOMMENDS STORAGE OF THE EVALUATION KIT IN A PROTECTIVE ESD BAG.

3 Regulatory Notices:

3.1 United States

3.1.1 Notice applicable to EVMs not FCC-Approved:

FCC NOTICE: This kit is designed to allow product developers to evaluate electronic components, circuitry, or software associated with the kit to determine whether to incorporate such items in a finished product and software developers to write software applications for use with the end product. This kit is not a finished product and when assembled may not be resold or otherwise marketed unless all required FCC equipment authorizations are first obtained. Operation is subject to the condition that this product not cause harmful interference to licensed radio stations and that this product accept harmful interference. Unless the assembled kit is designed to operate under part 15, part 18 or part 95 of this chapter, the operator of the kit must operate under the authority of an FCC license holder or must secure an experimental authorization under part 5 of this chapter.

3.1.2 For EVMs annotated as FCC – FEDERAL COMMUNICATIONS COMMISSION Part 15 Compliant:

CAUTION

This device complies with part 15 of the FCC Rules. Operation is subject to the following two conditions: (1) This device may not cause harmful interference, and (2) this device must accept any interference received, including interference that may cause undesired operation.

Changes or modifications not expressly approved by the party responsible for compliance could void the user's authority to operate the equipment.

FCC Interference Statement for Class A EVM devices

NOTE: This equipment has been tested and found to comply with the limits for a Class A digital device, pursuant to part 15 of the FCC Rules. These limits are designed to provide reasonable protection against harmful interference when the equipment is operated in a commercial environment. This equipment generates, uses, and can radiate radio frequency energy and, if not installed and used in accordance with the instruction manual, may cause harmful interference to radio communications. Operation of this equipment in a residential area is likely to cause harmful interference in which case the user will be required to correct the interference at his own expense.

FCC Interference Statement for Class B EVM devices

NOTE: This equipment has been tested and found to comply with the limits for a Class B digital device, pursuant to part 15 of the FCC Rules. These limits are designed to provide reasonable protection against harmful interference in a residential installation. This equipment generates, uses and can radiate radio frequency energy and, if not installed and used in accordance with the instructions, may cause harmful interference to radio communications. However, there is no guarantee that interference will not occur in a particular installation. If this equipment does cause harmful interference to radio or television reception, which can be determined by turning the equipment off and on, the user is encouraged to try to correct the interference by one or more of the following measures:

- Reorient or relocate the receiving antenna.
- Increase the separation between the equipment and receiver.
- Connect the equipment into an outlet on a circuit different from that to which the receiver is connected.
- Consult the dealer or an experienced radio/TV technician for help.

3.2 Canada

3.2.1 For EVMs issued with an Industry Canada Certificate of Conformance to RSS-210 or RSS-247

Concerning EVMs Including Radio Transmitters:

This device complies with Industry Canada license-exempt RSSs. Operation is subject to the following two conditions:

(1) this device may not cause interference, and (2) this device must accept any interference, including interference that may cause undesired operation of the device.

Concernant les EVMs avec appareils radio:

Le présent appareil est conforme aux CNR d'Industrie Canada applicables aux appareils radio exempts de licence. L'exploitation est autorisée aux deux conditions suivantes: (1) l'appareil ne doit pas produire de brouillage, et (2) l'utilisateur de l'appareil doit accepter tout brouillage radioélectrique subi, même si le brouillage est susceptible d'en compromettre le fonctionnement.

Concerning EVMs Including Detachable Antennas:

Under Industry Canada regulations, this radio transmitter may only operate using an antenna of a type and maximum (or lesser) gain approved for the transmitter by Industry Canada. To reduce potential radio interference to other users, the antenna type and its gain should be so chosen that the equivalent isotropically radiated power (e.i.r.p.) is not more than that necessary for successful communication. This radio transmitter has been approved by Industry Canada to operate with the antenna types listed in the user guide with the maximum permissible gain and required antenna impedance for each antenna type indicated. Antenna types not included in this list, having a gain greater than the maximum gain indicated for that type, are strictly prohibited for use with this device.

Concernant les EVMs avec antennes détachables

Conformément à la réglementation d'Industrie Canada, le présent émetteur radio peut fonctionner avec une antenne d'un type et d'un gain maximal (ou inférieur) approuvé pour l'émetteur par Industrie Canada. Dans le but de réduire les risques de brouillage radioélectrique à l'intention des autres utilisateurs, il faut choisir le type d'antenne et son gain de sorte que la puissance isotrope rayonnée équivalente (p.i.r.e.) ne dépasse pas l'intensité nécessaire à l'établissement d'une communication satisfaisante. Le présent émetteur radio a été approuvé par Industrie Canada pour fonctionner avec les types d'antenne énumérés dans le manuel d'usage et ayant un gain admissible maximal et l'impédance requise pour chaque type d'antenne. Les types d'antenne non inclus dans cette liste, ou dont le gain est supérieur au gain maximal indiqué, sont strictement interdits pour l'exploitation de l'émetteur.

3.3 Japan

3.3.1 *Notice for EVMs delivered in Japan:* Please see http://www.tij.co.jp/lstds/ti_ja/general/eStore/notice_01.page 日本国内に輸入される評価用キット、ボードについては、次のところをご覧ください。
http://www.tij.co.jp/lstds/ti_ja/general/eStore/notice_01.page

3.3.2 *Notice for Users of EVMs Considered "Radio Frequency Products" in Japan:* EVMs entering Japan may not be certified by TI as conforming to Technical Regulations of Radio Law of Japan.

If User uses EVMs in Japan, not certified to Technical Regulations of Radio Law of Japan, User is required to follow the instructions set forth by Radio Law of Japan, which includes, but is not limited to, the instructions below with respect to EVMs (which for the avoidance of doubt are stated strictly for convenience and should be verified by User):

1. Use EVMs in a shielded room or any other test facility as defined in the notification #173 issued by Ministry of Internal Affairs and Communications on March 28, 2006, based on Sub-section 1.1 of Article 6 of the Ministry's Rule for Enforcement of Radio Law of Japan,
2. Use EVMs only after User obtains the license of Test Radio Station as provided in Radio Law of Japan with respect to EVMs, or
3. Use of EVMs only after User obtains the Technical Regulations Conformity Certification as provided in Radio Law of Japan with respect to EVMs. Also, do not transfer EVMs, unless User gives the same notice above to the transferee. Please note that if User does not follow the instructions above, User will be subject to penalties of Radio Law of Japan.

【無線電波を送信する製品の開発キットをお使いになる際の注意事項】 開発キットの中には技術基準適合証明を受けていないものがあります。技術適合証明を受けていないものご使用に際しては、電波法遵守のため、以下のいずれかの措置を取っていただく必要がありますのでご注意ください。

1. 電波法施行規則第6条第1項第1号に基づく平成18年3月28日総務省告示第173号で定められた電波暗室等の試験設備でご使用いただく。
2. 実験局の免許を取得後ご使用いただく。
3. 技術基準適合証明を取得後ご使用いただく。

なお、本製品は、上記の「ご使用にあたっての注意」を譲渡先、移転先に通知しない限り、譲渡、移転できないものとします。

上記を遵守頂けない場合は、電波法の罰則が適用される可能性があることをご留意ください。日本テキサス・インスツルメンツ株式会社
東京都新宿区西新宿 6 丁目 2 4 番 1 号
西新宿三井ビル

3.3.3 *Notice for EVMs for Power Line Communication:* Please see http://www.tij.co.jp/lstds/ti_ja/general/eStore/notice_02.page
電力線搬送波通信についての開発キットをお使いになる際の注意事項については、次のところをご覧ください。http://www.tij.co.jp/lstds/ti_ja/general/eStore/notice_02.page

3.4 European Union

3.4.1 *For EVMs subject to EU Directive 2014/30/EU (Electromagnetic Compatibility Directive):*

This is a class A product intended for use in environments other than domestic environments that are connected to a low-voltage power-supply network that supplies buildings used for domestic purposes. In a domestic environment this product may cause radio interference in which case the user may be required to take adequate measures.

-
- 4 *EVM Use Restrictions and Warnings:*
 - 4.1 EVMS ARE NOT FOR USE IN FUNCTIONAL SAFETY AND/OR SAFETY CRITICAL EVALUATIONS, INCLUDING BUT NOT LIMITED TO EVALUATIONS OF LIFE SUPPORT APPLICATIONS.
 - 4.2 User must read and apply the user guide and other available documentation provided by TI regarding the EVM prior to handling or using the EVM, including without limitation any warning or restriction notices. The notices contain important safety information related to, for example, temperatures and voltages.
 - 4.3 *Safety-Related Warnings and Restrictions:*
 - 4.3.1 User shall operate the EVM within TI's recommended specifications and environmental considerations stated in the user guide, other available documentation provided by TI, and any other applicable requirements and employ reasonable and customary safeguards. Exceeding the specified performance ratings and specifications (including but not limited to input and output voltage, current, power, and environmental ranges) for the EVM may cause personal injury or death, or property damage. If there are questions concerning performance ratings and specifications, User should contact a TI field representative prior to connecting interface electronics including input power and intended loads. Any loads applied outside of the specified output range may also result in unintended and/or inaccurate operation and/or possible permanent damage to the EVM and/or interface electronics. Please consult the EVM user guide prior to connecting any load to the EVM output. If there is uncertainty as to the load specification, please contact a TI field representative. During normal operation, even with the inputs and outputs kept within the specified allowable ranges, some circuit components may have elevated case temperatures. These components include but are not limited to linear regulators, switching transistors, pass transistors, current sense resistors, and heat sinks, which can be identified using the information in the associated documentation. When working with the EVM, please be aware that the EVM may become very warm.
 - 4.3.2 EVMs are intended solely for use by technically qualified, professional electronics experts who are familiar with the dangers and application risks associated with handling electrical mechanical components, systems, and subsystems. User assumes all responsibility and liability for proper and safe handling and use of the EVM by User or its employees, affiliates, contractors or designees. User assumes all responsibility and liability to ensure that any interfaces (electronic and/or mechanical) between the EVM and any human body are designed with suitable isolation and means to safely limit accessible leakage currents to minimize the risk of electrical shock hazard. User assumes all responsibility and liability for any improper or unsafe handling or use of the EVM by User or its employees, affiliates, contractors or designees.
 - 4.4 User assumes all responsibility and liability to determine whether the EVM is subject to any applicable international, federal, state, or local laws and regulations related to User's handling and use of the EVM and, if applicable, User assumes all responsibility and liability for compliance in all respects with such laws and regulations. User assumes all responsibility and liability for proper disposal and recycling of the EVM consistent with all applicable international, federal, state, and local requirements.
 5. *Accuracy of Information:* To the extent TI provides information on the availability and function of EVMs, TI attempts to be as accurate as possible. However, TI does not warrant the accuracy of EVM descriptions, EVM availability or other information on its websites as accurate, complete, reliable, current, or error-free.
 6. *Disclaimers:*
 - 6.1 EXCEPT AS SET FORTH ABOVE, EVMS AND ANY MATERIALS PROVIDED WITH THE EVM (INCLUDING, BUT NOT LIMITED TO, REFERENCE DESIGNS AND THE DESIGN OF THE EVM ITSELF) ARE PROVIDED "AS IS" AND "WITH ALL FAULTS." TI DISCLAIMS ALL OTHER WARRANTIES, EXPRESS OR IMPLIED, REGARDING SUCH ITEMS, INCLUDING BUT NOT LIMITED TO ANY EPIDEMIC FAILURE WARRANTY OR IMPLIED WARRANTIES OF MERCHANTABILITY OR FITNESS FOR A PARTICULAR PURPOSE OR NON-INFRINGEMENT OF ANY THIRD PARTY PATENTS, COPYRIGHTS, TRADE SECRETS OR OTHER INTELLECTUAL PROPERTY RIGHTS.
 - 6.2 EXCEPT FOR THE LIMITED RIGHT TO USE THE EVM SET FORTH HEREIN, NOTHING IN THESE TERMS SHALL BE CONSTRUED AS GRANTING OR CONFERRING ANY RIGHTS BY LICENSE, PATENT, OR ANY OTHER INDUSTRIAL OR INTELLECTUAL PROPERTY RIGHT OF TI, ITS SUPPLIERS/LICENSORS OR ANY OTHER THIRD PARTY, TO USE THE EVM IN ANY FINISHED END-USER OR READY-TO-USE FINAL PRODUCT, OR FOR ANY INVENTION, DISCOVERY OR IMPROVEMENT, REGARDLESS OF WHEN MADE, CONCEIVED OR ACQUIRED.
 7. *USER'S INDEMNITY OBLIGATIONS AND REPRESENTATIONS.* USER WILL DEFEND, INDEMNIFY AND HOLD TI, ITS LICENSORS AND THEIR REPRESENTATIVES HARMLESS FROM AND AGAINST ANY AND ALL CLAIMS, DAMAGES, LOSSES, EXPENSES, COSTS AND LIABILITIES (COLLECTIVELY, "CLAIMS") ARISING OUT OF OR IN CONNECTION WITH ANY HANDLING OR USE OF THE EVM THAT IS NOT IN ACCORDANCE WITH THESE TERMS. THIS OBLIGATION SHALL APPLY WHETHER CLAIMS ARISE UNDER STATUTE, REGULATION, OR THE LAW OF TORT, CONTRACT OR ANY OTHER LEGAL THEORY, AND EVEN IF THE EVM FAILS TO PERFORM AS DESCRIBED OR EXPECTED.
-

8. *Limitations on Damages and Liability:*

8.1 *General Limitations.* IN NO EVENT SHALL TI BE LIABLE FOR ANY SPECIAL, COLLATERAL, INDIRECT, PUNITIVE, INCIDENTAL, CONSEQUENTIAL, OR EXEMPLARY DAMAGES IN CONNECTION WITH OR ARISING OUT OF THESE TERMS OR THE USE OF THE EVMS , REGARDLESS OF WHETHER TI HAS BEEN ADVISED OF THE POSSIBILITY OF SUCH DAMAGES. EXCLUDED DAMAGES INCLUDE, BUT ARE NOT LIMITED TO, COST OF REMOVAL OR REINSTALLATION, ANCILLARY COSTS TO THE PROCUREMENT OF SUBSTITUTE GOODS OR SERVICES, RETESTING, OUTSIDE COMPUTER TIME, LABOR COSTS, LOSS OF GOODWILL, LOSS OF PROFITS, LOSS OF SAVINGS, LOSS OF USE, LOSS OF DATA, OR BUSINESS INTERRUPTION. NO CLAIM, SUIT OR ACTION SHALL BE BROUGHT AGAINST TI MORE THAN TWELVE (12) MONTHS AFTER THE EVENT THAT GAVE RISE TO THE CAUSE OF ACTION HAS OCCURRED.

8.2 *Specific Limitations.* IN NO EVENT SHALL TI'S AGGREGATE LIABILITY FROM ANY USE OF AN EVM PROVIDED HEREUNDER, INCLUDING FROM ANY WARRANTY, INDEMNITY OR OTHER OBLIGATION ARISING OUT OF OR IN CONNECTION WITH THESE TERMS, , EXCEED THE TOTAL AMOUNT PAID TO TI BY USER FOR THE PARTICULAR EVM(S) AT ISSUE DURING THE PRIOR TWELVE (12) MONTHS WITH RESPECT TO WHICH LOSSES OR DAMAGES ARE CLAIMED. THE EXISTENCE OF MORE THAN ONE CLAIM SHALL NOT ENLARGE OR EXTEND THIS LIMIT.

9. *Return Policy.* Except as otherwise provided, TI does not offer any refunds, returns, or exchanges. Furthermore, no return of EVM(s) will be accepted if the package has been opened and no return of the EVM(s) will be accepted if they are damaged or otherwise not in a resalable condition. If User feels it has been incorrectly charged for the EVM(s) it ordered or that delivery violates the applicable order, User should contact TI. All refunds will be made in full within thirty (30) working days from the return of the components(s), excluding any postage or packaging costs.

10. *Governing Law:* These terms and conditions shall be governed by and interpreted in accordance with the laws of the State of Texas, without reference to conflict-of-laws principles. User agrees that non-exclusive jurisdiction for any dispute arising out of or relating to these terms and conditions lies within courts located in the State of Texas and consents to venue in Dallas County, Texas. Notwithstanding the foregoing, any judgment may be enforced in any United States or foreign court, and TI may seek injunctive relief in any United States or foreign court.

Mailing Address: Texas Instruments, Post Office Box 655303, Dallas, Texas 75265
Copyright © 2019, Texas Instruments Incorporated

IMPORTANT NOTICE AND DISCLAIMER

TI PROVIDES TECHNICAL AND RELIABILITY DATA (INCLUDING DATASHEETS), DESIGN RESOURCES (INCLUDING REFERENCE DESIGNS), APPLICATION OR OTHER DESIGN ADVICE, WEB TOOLS, SAFETY INFORMATION, AND OTHER RESOURCES "AS IS" AND WITH ALL FAULTS, AND DISCLAIMS ALL WARRANTIES, EXPRESS AND IMPLIED, INCLUDING WITHOUT LIMITATION ANY IMPLIED WARRANTIES OF MERCHANTABILITY, FITNESS FOR A PARTICULAR PURPOSE OR NON-INFRINGEMENT OF THIRD PARTY INTELLECTUAL PROPERTY RIGHTS.

These resources are intended for skilled developers designing with TI products. You are solely responsible for (1) selecting the appropriate TI products for your application, (2) designing, validating and testing your application, and (3) ensuring your application meets applicable standards, and any other safety, security, or other requirements. These resources are subject to change without notice. TI grants you permission to use these resources only for development of an application that uses the TI products described in the resource. Other reproduction and display of these resources is prohibited. No license is granted to any other TI intellectual property right or to any third party intellectual property right. TI disclaims responsibility for, and you will fully indemnify TI and its representatives against, any claims, damages, costs, losses, and liabilities arising out of your use of these resources.

TI's products are provided subject to TI's Terms of Sale (www.ti.com/legal/termsofsale.html) or other applicable terms available either on ti.com or provided in conjunction with such TI products. TI's provision of these resources does not expand or otherwise alter TI's applicable warranties or warranty disclaimers for TI products.

Mailing Address: Texas Instruments, Post Office Box 655303, Dallas, Texas 75265
Copyright © 2019, Texas Instruments Incorporated