

Housing - HC-STA-B06-BWS-ELC-AL - 1411318

Please be informed that the data shown in this PDF Document is generated from our Online Catalog. Please find the complete data in the user's documentation. Our General Terms of Use for Downloads are valid (<http://phoenixcontact.com/download>)



HEAVYCON B6 panel mounting base, with single locking latch, with flat gasket, salt-water-resistant aluminum, conductive profile gasket

Your advantages

- ✓ good shielding in the event of electromagnetic interference



Key Commercial Data

Packing unit	1 pc
GTIN	 4 046356 927192
GTIN	4046356927192

Technical data

Dimensions

Height	30.5 mm
Width	53 mm
Length	80.5 mm
Length of the assembly cutout	52 mm
Width of the assembly cutout	35 mm

Ambient conditions

Degree of protection (IP)	IP66
	IP67
Degree of protection (NEMA)	4 (UL 50e)
	4X (UL 50e)
	12 (UL 50e)
Ambient temperature (operation)	-40 °C ... 125 °C

General

Housing - HC-STA-B06-BWS-ELC-AL - 1411318

Technical data

General

Note	For contact inserts HC-B6, BB10, DD24, M
Size	B6
Housing type	Panel mounting base
Color	gray aluminum
Locking type	with single locking latch
Torque	1.5 Nm ... 2 Nm (Mounting screw)
Screw connection	none
Housing material	Die-cast aluminum, salt water resistant
Housing surface material	uncoated
Seal material	NBR, conductive
Material lock	PA

Environmental Product Compliance

China RoHS	Environmentally friendly use period: unlimited = EFUP-e
	No hazardous substances above threshold values

Drawings

Dimensional drawing

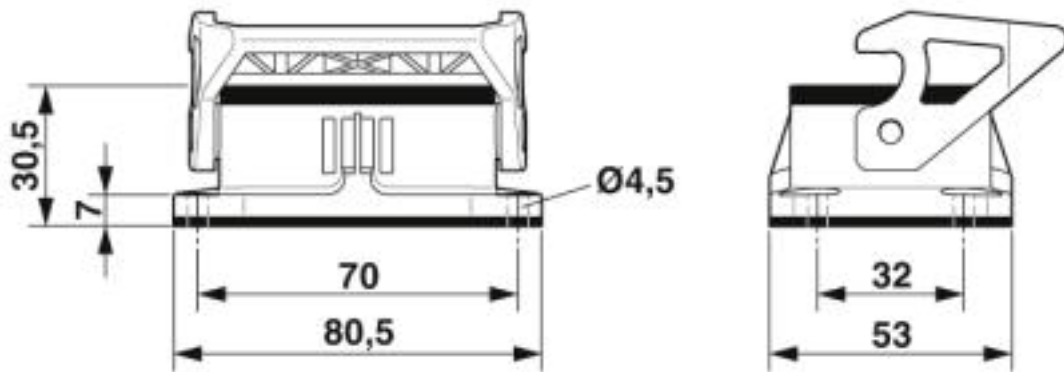

Dimensional drawing

Housing - HC-STA-B06-BWS-ELC-AL - 1411318

Dimensional drawing

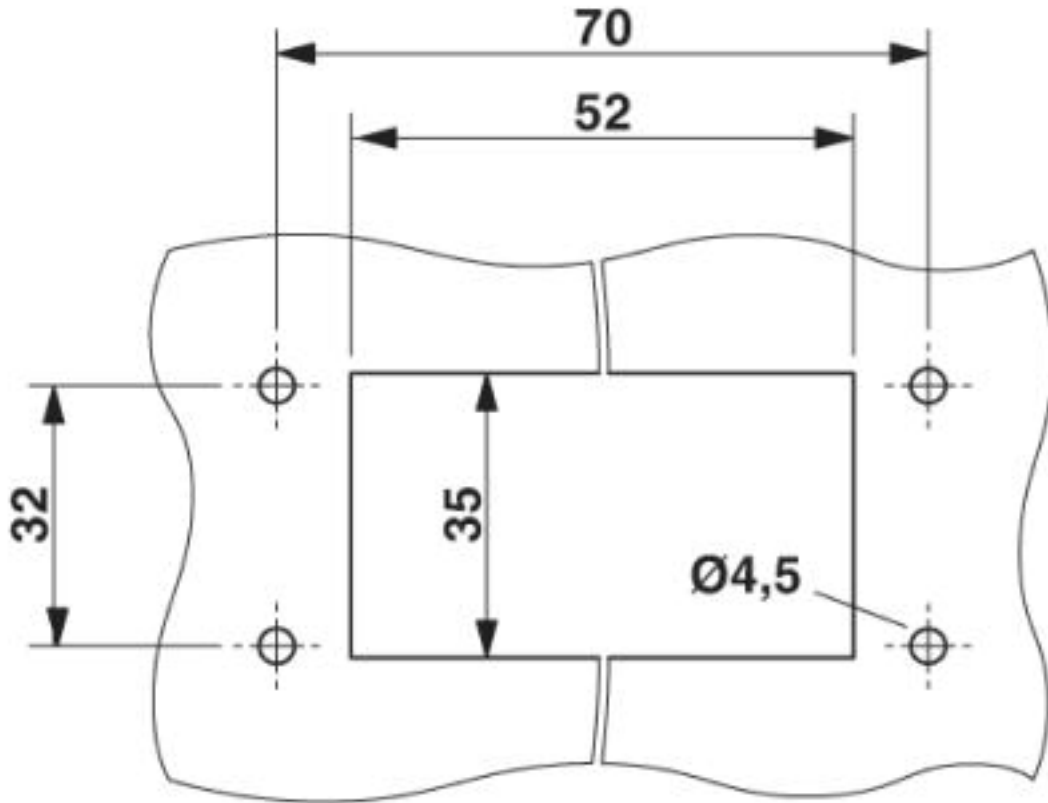

Mounting cutout

Approvals

Approvals

Approvals

UL Recognized / cUL Recognized / EAC / DNV GL / cULus Recognized

Ex Approvals

Approval details

UL Recognized





<http://database.ul.com/cgi-bin/XYV/template/LISEXT/1FRAME/index.htm>

E255026

Housing - HC-STA-B06-BWS-ELC-AL - 1411318

Approvals

cUL Recognized		http://database.ul.com/cgi-bin/XYV/template/LISEXT/1FRAME/index.htm	E255026
----------------	---	---	---------

EAC			RU C- DE.AI30.B.01102
-----	---	--	--------------------------

DNV GL		https://approvalfinder.dnvgl.com/	TAE000037S
--------	---	---	------------

cULus Recognized			
------------------	---	--	--

Phoenix Contact 2019 © - all rights reserved
<http://www.phoenixcontact.com>

PHOENIX CONTACT GmbH & Co. KG
Flachsmarktstr. 8
32825 Blomberg
Germany
Tel. +49 5235 300
Fax +49 5235 3 41200
<http://www.phoenixcontact.com>