

# 0.30MM CENTER FFC JUMPER CABLE CHART

## NOTES:

1. SUBSTRATE AND COVERLAY MATERIAL IS .001" [25um] POLYIMIDE.
2. CONDUCTOR IS 1/2 OZ (.0007") [18um] COPPER.
3. PLATING IS 2 MICRO INCHES MINIMUM OF HARD GOLD OVER 100 MICRO INCHES MINIMUM OF NICKEL.
4. TAIL ENDS ARE .008±.001 [0.20±0.03] THICK.
5. JUMPER CABLES ARE SUITABLE FOR USE WITH MOLEX 504754 SERIES CONNECTOR.

| "A" DIM. | 2 ± .08 INCHES<br>51 ± 2 MM | 4 ± .16 INCHES<br>102 ± 4 MM | 6 ± .16 INCHES<br>152 ± 4 MM | 8 ± .20 INCHES<br>203 ± 5 MM | 10 ± .20 INCHES<br>254 ± 5 MM | 12 ± .20 INCHES<br>305 ± 5 MM |
|----------|-----------------------------|------------------------------|------------------------------|------------------------------|-------------------------------|-------------------------------|
| CKTS: 7  | 150310207                   | 150310407                    | 150310607                    | 150310807                    | 150311007                     | 150311207                     |
| CKTS: 9  | 150310209                   | 150310409                    | 150310609                    | 150310809                    | 150311009                     | 150311209                     |
| CKTS: 11 | 150310211                   | 150310411                    | 150310611                    | 150310811                    | 150311011                     | 150311211                     |
| CKTS: 15 | 150310215                   | 150310415                    | 150310615                    | 150310815                    | 150311015                     | 150311215                     |
| CKTS: 21 | 150310221                   | 150310421                    | 150310621                    | 150310821                    | 150311021                     | 150311221                     |
| CKTS: 25 | 150310225                   | 150310425                    | 150310625                    | 150310825                    | 150311025                     | 150311225                     |
| CKTS: 31 | 150310231                   | 150310431                    | 150310631                    | 150310831                    | 150311031                     | 150311231                     |
| CKTS: 33 | 150310233                   | 150310433                    | 150310633                    | 150310833                    | 150311033                     | 150311233                     |
| CKTS: 35 | 150310235                   | 150310435                    | 150310635                    | 150310835                    | 150311035                     | 150311235                     |
| CKTS: 37 | 150310237                   | 150310437                    | 150310637                    | 150310837                    | 150311037                     | 150311237                     |
| CKTS: 39 | 150310239                   | 150310439                    | 150310639                    | 150310839                    | 150311039                     | 150311239                     |
| CKTS: 41 | 150310241                   | 150310441                    | 150310641                    | 150310841                    | 150311041                     | 150311241                     |
| CKTS: 51 | 150310251                   | 150310451                    | 150310651                    | 150310851                    | 150311051                     | 150311251                     |
| CKTS: 61 | 150310261                   | 150310461                    | 150310661                    | 150310861                    | 150311061                     | 150311261                     |

N = NUMBER OF CONDUCTORS

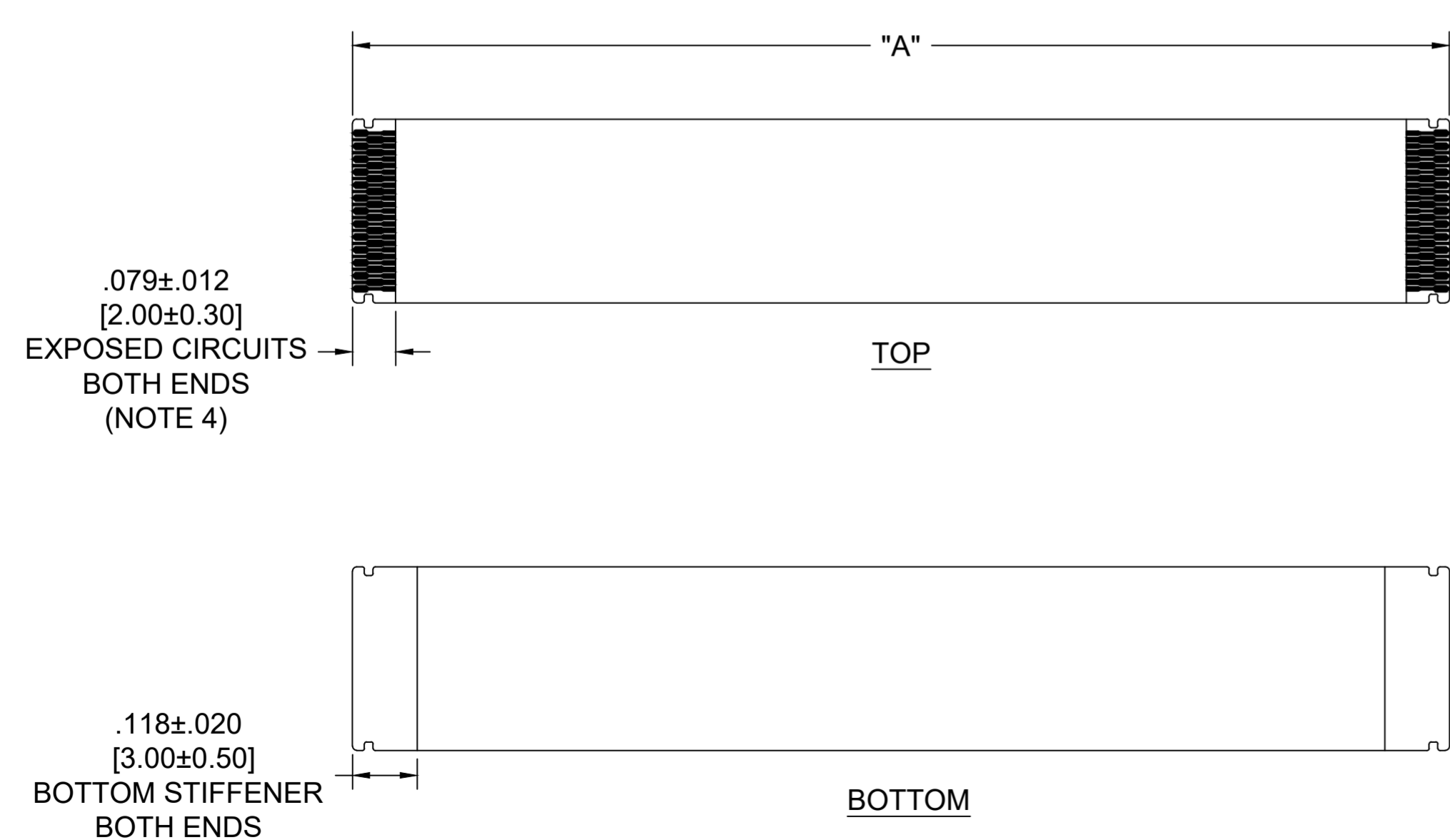
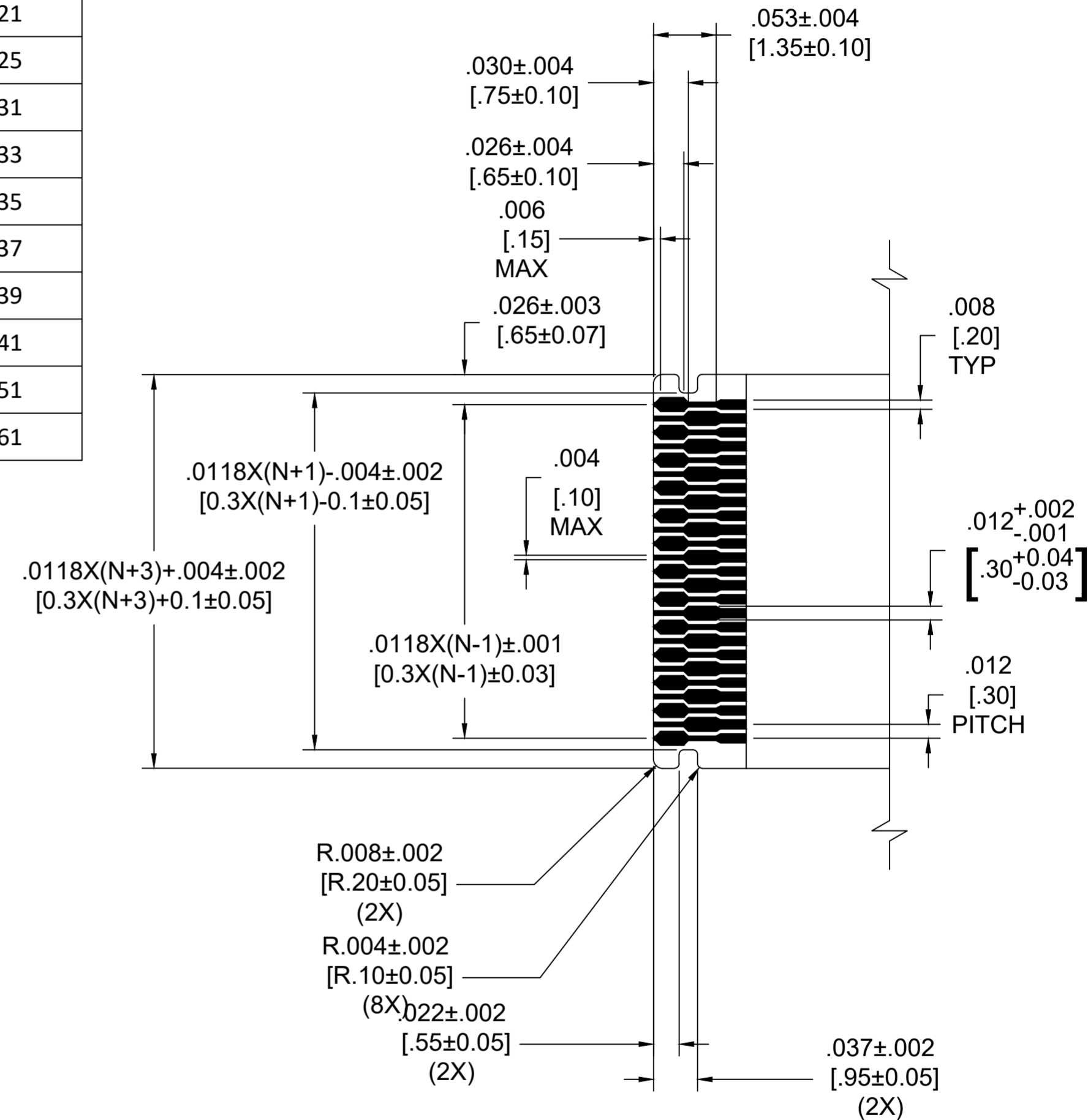

JUMPER END DETAIL  
25 CIRCUIT SHOWN  
(SCALE 10:1)

|                    |   |                |                                      |
|--------------------|---|----------------|--------------------------------------|
| FUNCTIONAL SYMBOLS | THIS DRAWING CONTAINS INFORMATION THAT IS PROPRIETARY TO MOLEX ELECTRONIC TECHNOLOGIES, LLC AND SHOULD NOT BE USED WITHOUT WRITTEN PERMISSION |                |                                      |
|                    | DIMENSION UNITS   | SCALE          | CURRENT REV DESC: PRODUCTION RELEASE |
| FA=0               | MM/INCH   | 4:1            |                                      |
| EC=0               | GENERAL TOLERANCES (UNLESS SPECIFIED)   |                |                                      |
| DIVISIONAL SYMBOLS |   | mm             | INCH                                 |
|                    | 4 PLACES  | ±----          | ±----                                |
|                    | 3 PLACES  | ±----          | ±0.01                                |
|                    | 2 PLACES  | ±----          | ±0.03                                |
|                    | 1 PLACE   | ±----          | ±----                                |
|                    | 0 PLACES  | ±----          | ±----                                |
|                    | ANGULAR TOL ± 1.0 °   |                |                                      |
|                    | DRAFT WHERE APPLICABLE MUST REMAIN WITHIN DIMENSIONS  |                |                                      |
|                    | THIRD ANGLE PROJECTION  | DRAWING        | SERIES                               |
|                    |   | C-SIZE         | 15031                                |
|                    | EC NO: 701160   | DRWN: MIMIG    | 2022/03/28                           |
|                    | CHK'D: JSMITH11   | APPR: JSMITH11 | 2022/03/30                           |
|                    | INITIAL REVISION:   |                |                                      |
|                    | DRWN: MIMIG   | APPR: JSMITH11 | 2022/03/28                           |
|                    | APPR: JSMITH11  |                | 2022/03/30                           |
|                    | DOCUMENT NUMBER   |                | DOC TYPE   DOC PART   REVISION       |
|                    | 150310001   |                | PSD   000   A                        |
|                    | MATERIAL NUMBER   | CUSTOMER       | SHEET NUMBER                         |
|                    | SEE CHART   | GENERAL MARKET | 1 OF 1                               |