

# DLP660TE 0.66 4K UHD DMD

## 1 Features

- 0.66-Inch diagonal micromirror array
  - System displays 4K ultra high definition (UHD) 3840 x 2160 pixels on the screen
  - 5.4-Micron micromirror pitch
  - ±17° micromirror tilt (relative to flat surface)
  - Bottom illumination
- 2xLVDS input data bus
- Dedicated DLPC4422 display controller and DLPA100 power management IC and motor driver for reliable operation

## 2 Applications

- 4K UHD display
- Digital signage
- Laser TV
- Projection mapping

## 3 Description

The TI DLP660TE digital micromirror device (DMD) is a digitally controlled micro-opto-electromechanical system (MOEMS) spatial light modulator (SLM) that enables bright, affordable full 4K UHD display solutions. When coupled to an appropriate optical system, DLP660TE DMD displays true 4K UHD resolution (8.3M pixels on screen) and is capable of delivering accurate, detailed images to a variety of surfaces. The DLP660TE DMD, together with the DLPC4422 display controller and DLPA100 power and motor driver, comprise the DLP® 4K UHD chipset. This solution is a great fit for display systems that require high resolution, high brightness and system simplicity.

### Device Information<sup>(1)</sup>

PART NUMBER	PACKAGE	BODY SIZE (NOM)
DLP660TE	FYG (350)	35mm x 32mm

(1) For all available packages, see the orderable addendum at the end of the data sheet.

### DLP® DLP660TE 0.66 4K UHD DMD

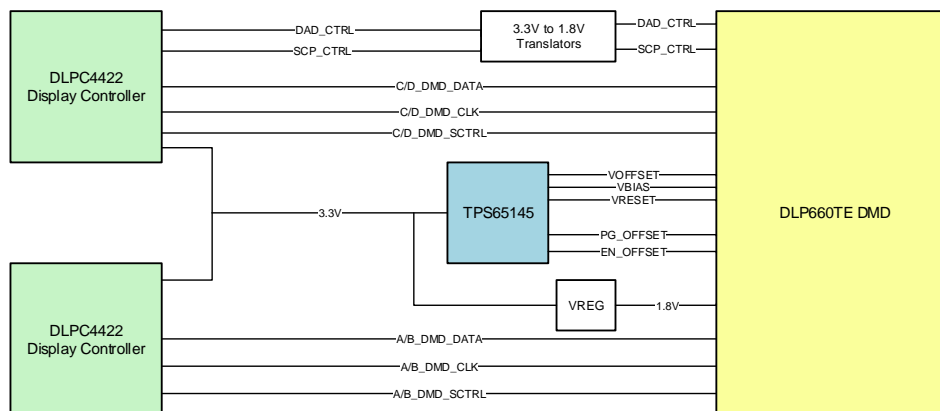

## Table of Contents

<b>1 Features</b> .....	<b>1</b>	7.4 Device Functional Modes.....	<b>24</b>
<b>2 Applications</b> .....	<b>1</b>	7.5 Optical Interface and System Image Quality Considerations .....	<b>24</b>
<b>3 Description</b> .....	<b>1</b>	7.6 Micromirror Array Temperature Calculation.....	<b>25</b>
<b>4 Revision History</b> .....	<b>2</b>	7.7 Micromirror Landed-On/Landed-Off Duty Cycle .....	<b>26</b>
<b>5 Pin Configuration and Functions</b> .....	<b>3</b>	<b>8 Application and Implementation</b> .....	<b>29</b>
<b>6 Specifications</b> .....	<b>11</b>	8.1 Application Information.....	<b>29</b>
6.1 Absolute Maximum Ratings .....	<b>11</b>	8.2 Typical Application .....	<b>29</b>
6.2 Storage Conditions.....	<b>12</b>	8.3 DMD Die Temperature Sensing.....	<b>30</b>
6.3 ESD Ratings.....	<b>12</b>	<b>9 Power Supply Recommendations</b> .....	<b>32</b>
6.4 Recommended Operating Conditions.....	<b>12</b>	9.1 DMD Power Supply Power-Up Procedure .....	<b>32</b>
6.5 Thermal Information .....	<b>15</b>	9.2 DMD Power Supply Power-Down Procedure .....	<b>32</b>
6.6 Electrical Characteristics.....	<b>15</b>	<b>10 Layout</b> .....	<b>35</b>
6.7 Capacitance at Recommended Operating Conditions .....	<b>15</b>	10.1 Layout Guidelines .....	<b>35</b>
6.8 Timing Requirements .....	<b>16</b>	10.2 Layout Example .....	<b>35</b>
6.9 System Mounting Interface Loads .....	<b>19</b>	<b>11 Device and Documentation Support</b> .....	<b>37</b>
6.10 Micromirror Array Physical Characteristics .....	<b>19</b>	11.1 Device Support.....	<b>37</b>
6.11 Micromirror Array Optical Characteristics .....	<b>21</b>	11.2 Documentation Support .....	<b>38</b>
6.12 Window Characteristics.....	<b>22</b>	11.3 Receiving Notification of Documentation Updates	<b>38</b>
6.13 Chipset Component Usage Specification .....	<b>22</b>	11.4 Community Resources.....	<b>38</b>
<b>7 Detailed Description</b> .....	<b>23</b>	11.5 Trademarks .....	<b>38</b>
7.1 Overview .....	<b>23</b>	11.6 Electrostatic Discharge Caution.....	<b>38</b>
7.2 Functional Block Diagram .....	<b>23</b>	11.7 Glossary .....	<b>38</b>
7.3 Feature Description.....	<b>24</b>	<b>12 Mechanical, Packaging, and Orderable Information</b> .....	<b>39</b>

## 4 Revision History

NOTE: Page numbers for previous revisions may differ from page numbers in the current version.

DATE	REVISION	NOTES
April 2019	*	Initial release.

## 5 Pin Configuration and Functions

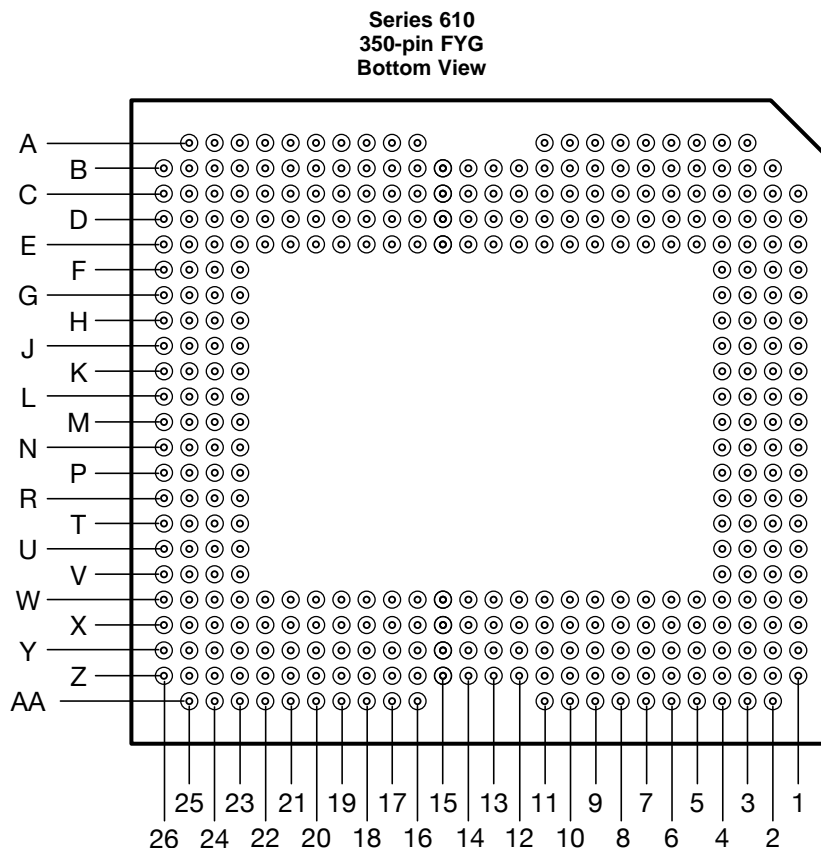

### CAUTION

To ensure reliable, long-term operation of the .66" UHD S610 DMD, it is critical to properly manage the layout and operation of the signals identified in the table below. For specific details and guidelines, refer to the [PCB Design Requirements for TI DLP Standard TRP Digital Micromirror Devices](#) application report before designing the board.

**Pin Functions**

PIN		TYPE	SIGNAL	DATA RATE	DESCRIPTION
NAME	NO.				
<b>DATA INPUTS</b>					
D_AN(0)	C7	Input	2xLVDS		LVDS pair for Data Bus A (15:0)
D_AP(0)	C8				
D_AN(1)	D4				
D_AP(1)	E4				
D_AN(2)	C5				
D_AP(2)	C4				
D_AN(3)	D6				
D_AP(3)	C6				
D_AN(4)	D8				
D_AP(4)	D7				
D_AN(5)	D3				
D_AP(5)	E3				
D_AN(6)	B3				
D_AP(6)	C3				
D_AN(7)	E11				
D_AP(7)	E10				
D_AN(8)	E6				
D_AP(8)	E5				
D_AN(9)	B10				
D_AP(9)	C10				
D_AN(10)	B8				
D_AP(10)	B9				
D_AN(11)	C13				
D_AP(11)	C14				
D_AN(12)	D15				
D_AP(12)	E15				
D_AN(13)	B12				
D_AP(13)	B13				
D_AN(14)	B15				
D_AP(14)	B16				
D_AN(15)	C16				
D_AP(15)	C17				

**Pin Functions (continued)**

PIN		TYPE	SIGNAL	DATA RATE	DESCRIPTION
NAME	NO.				
D_BN(0)	Y8	Input	2xLVDS		LVDS pair for Data Bus B (15:0)
D_BP(0)	Y7				
D_BN(1)	X4				
D_BP(1)	W4				
D_BN(2)	Z3				
D_BP(2)	Y3				
D_BN(3)	X6				
D_BP(3)	Y6				
D_BN(4)	X8				
D_BP(4)	X7				
D_BN(5)	X3				
D_BP(5)	W3				
D_BN(6)	W15				
D_BP(6)	X15				
D_BN(7)	W11				
D_BP(7)	W10				
D_BN(8)	W6				
D_BP(8)	W5				
D_BN(9)	AA9				
D_BP(9)	AA10				
D_BN(10)	Z8				
D_BP(10)	Z9				
D_BN(11)	Y13				
D_BP(11)	Y14				
D_BN(12)	Z10				
D_BP(12)	Y10				
D_BN(13)	Z12				
D_BP(13)	Z13				
D_BN(14)	Z15				
D_BP(14)	Z16				
D_BN(15)	Y16				
D_BP(15)	Y17				

**Pin Functions (continued)**

PIN		TYPE	SIGNAL	DATA RATE	DESCRIPTION
NAME	NO.				
D_CN(0)	C18	Input	2xLVDS		LVDS pair for Data Bus C (15:0)
D_CP(0)	C19				
D_CN(1)	A20				
D_CP(1)	A19				
D_CN(2)	L23				
D_CP(2)	K23				
D_CN(3)	C23				
D_CP(3)	B23				
D_CN(4)	G23				
D_CP(4)	H23				
D_CN(5)	H24				
D_CP(5)	G24				
D_CN(6)	B18				
D_CP(6)	B19				
D_CN(7)	C21				
D_CP(7)	B21				
D_CN(8)	D23				
D_CP(8)	E23				
D_CN(9)	D25				
D_CP(9)	C25				
D_CN(10)	L24				
D_CP(10)	K24				
D_CN(11)	K25				
D_CP(11)	J25				
D_CN(12)	B24				
D_CP(12)	A24				
D_CN(13)	D26				
D_CP(13)	C26				
D_CN(14)	G25				
D_CP(14)	F25				
D_CN(15)	K26				
D_CP(15)	J26				

**Pin Functions (continued)**

PIN		TYPE	SIGNAL	DATA RATE	DESCRIPTION
NAME	NO.				
D_DN(0)	Y18	Input	2xLVDS		LVDS pair for Data Bus D (15:0)
D_DP(0)	Y19				
D_DN(1)	AA20				
D_DP(1)	AA19				
D_DN(2)	N23				
D_DP(2)	P23				
D_DN(3)	Y23				
D_DP(3)	Z23				
D_DN(4)	U23				
D_DP(4)	T23				
D_DN(5)	T24				
D_DP(5)	U24				
D_DN(6)	Z18				
D_DP(6)	Z19				
D_DN(7)	Y21				
D_DP(7)	Z21				
D_DN(8)	X23				
D_DP(8)	W23				
D_DN(9)	X25				
D_DP(9)	Y25				
D_DN(10)	N24				
D_DP(10)	P24				
D_DN(11)	P25				
D_DP(11)	R25				
D_DN(12)	Z24				
D_DP(12)	AA24				
D_DN(13)	X26				
D_DP(13)	Y26				
D_DN(14)	U25				
D_DP(14)	V25				
D_DN(15)	P26				
D_DP(15)	R26				
DCLK_AN	B6	Input			LVDS pair for Data Clock A
DCLK_AP	B5	Input			LVDS pair for Data Clock B
DCLK_BN	Z6				
DCLK_BP	Z5	Input			LVDS pair for Data Clock C
DCLK_CN	G26				
DCLK_CP	F26	Input			LVDS pair for Data Clock D.
DCLK_DN	U26				
DCLK_DP	V26				
<b>DATA CONTROL INPUTS</b>					
SCTRL_AN	A10	Input			LVDS pair for Serial Control (Sync) A
SCTRL_AP	A9				
SCTRL_BN	Y4	Input			LVDS pair for Serial Control (Sync) B
SCTRL_BP	Y5				

**Pin Functions (continued)**

PIN		TYPE	SIGNAL	DATA RATE	DESCRIPTION
NAME	NO.				
SCTRL_CN	E24	Input			LVDS pair for Serial Control (Sync) C
SCTRL_CP	D24				
SCTRL_DN	W24	Input			LVDS pair for Serial Control (Sync) D
SCTRL_DP	X24				
<b>DAD CONTROL INPUTS</b>					
RESET_ADDR(0)	R3	Input			Reset Driver Address Select. Bond Pad connects to an internal Pull Down circuit
RESET_ADDR(1)	R4				
RESET_ADDR(2)	T3				
RESET_ADDR(3)	U2				
RESET_MODE(0)	P4	Input			Reset Driver Mode Select. Bond Pad connects to an internal Pull Down circuit
RESET_MODE(1)	V3				
RESET_OEZ	R2	Input			Active Low. Output Enable signal for internal Reset Driver circuitry. Bond Pad connects to an internal Pull Up circuit
RESET_SEL(0)	P3	Input			Reset Driver Level Select. Bond Pad connects to an internal Pull Down circuit
RESET_SEL(1)	V2				
RESET_STROBE	W8	Input			Rising edge on RESET_STROBE latches in the control signals. Bond Pad connects to an internal Pull Down circuit
RESETZ	U4	Input			Active Low. Places reset circuitry in known VOFFSET state. Bond Pad connects to an internal Pull Down circuit
<b>SCP CONTROL</b>					
SCPCLK	W17	Input			Serial Communications Port Clock. SCPCLK is only active when SCPENZ goes low. Bond Pad connects to an internal Pull Down circuit
SCPMI	W18	Input			Serial Communications Port Data. Synchronous to the Rising Edge of SCPCLK. Bond Pad connects to an internal Pull Down circuit
SCPENZ	X18	Input			Active Low Serial Communications Port Enable. Bond Pad connects to an internal Pull Down circuit
SCPDO	W16	Output			Serial Communications Port output
<b>EXTERNAL REGULATOR SIGNALS</b>					
EN_BIAS	J4	Output			Active High. Enable signal for external VBIAS regulator
EN_OFFSET	H3	Output			Active High. Enable signal for external VOFFSET regulator
EN_RESET	J3	Output			Active High. Enable signal for external VRESET regulator
<b>OTHER SIGNALS</b>					
RESET_IRQZ	U3	Output			Active Low. Output Interrupt to DLP controller (ASIC)
TEMP_PLUS	E16	Analog			Temperature Sensor Diode Anode. <sup>(1)</sup>
TEMP_MINUS	E17	Analog			Temperature Sensor Diode Cathode. <sup>(1)</sup>
<b>POWER</b>					
VBIAS	A5, A6, A7	Power			Power supply for Positive Bias level of micromirror reset signal

(1) VSS must be connected for proper DMD operation.



**Pin Functions (continued)**

PIN		TYPE	SIGNAL	DATA RATE	DESCRIPTION
NAME	NO.				
V <sub>CC</sub>	A8, B2, C1, D1, D10, D12, D19, E1, E19, E20, E21, F1, K1, L1, M1, N1, P1, V1, W1, W19, W20, W21, X1, X10, X12, X19, Y1, Z1, Z2, AA2, AA8,	Power			Power supply for low voltage CMOS logic. Power supply for normal high voltage at micromirror address electrodes. Power supply for Offset level of Dow during power down sequence
V <sub>CCI</sub>	A11, A16, A17, A18, A21, A22, A23, AA11, AA16, AA17, AA18, AA21, AA22, AA23,	Power			Power supply for low voltage CMOS LVDS interface
V <sub>OFFSET</sub>	A3, A4, A25, B26, L26, M26, N26, Z26, AA3, AA4, AA25	Power			Power supply for high voltage CMOS logic. Power supply for stepped high voltage at micromirror address electrodes. Power supply for Offset level of MBRST(15:0)
V <sub>RESET</sub>	G1, H1, J1, R1, T1, U1	Power			Power supply for Negative Reset level of micromirror reset signal
V <sub>SS</sub> (Ground)	B4, B7, B11, B14, B17, B20, B22, B25, C2, C9, C20, C22, C24, D2, D5, D9, D11, D14, D18, D20, D21, D22, E2, E7, E9, E22, E25, E26, F4, F23, F24, H2, H4, H25, H26, J23, J24, K2, L2, L3, L4, L25, M2, M3, M4, M23, M24, M25, N2, N3, N25, P2, R23, R24, T2, T4, T25, T26, V4, V23, V24, W2, W7, W9, W22, W25, W26, X2, X5, X9, X11, X20, X21, X22, Y2, Y9, Y20, Y22, Y24, Z4, Z7, Z11, Z14, Z17, Z20, Z22, Z25	Ground			Common Return for all power
<b>RESERVED SIGNALS</b>					
RESERVED_PFE	E18	Ground			Connect to ground on the DLP® system board. Bond Pad connects to an internal Pull Down circuit
RESERVED_TM	G4	Ground			Connect to ground on the DLP® system board. Bond Pad connects to an internal Pull Down circuit
RESERVED_TP0	E8	Input			Do Not Connect on the DLP® system board
RESERVED_TP1	J2	Input			Do Not Connect on the DLP® system board
RESERVED_TP2	G2	Input			Do Not Connect on the DLP® system board
RESERVED_BA	N4	Output			Do Not Connect on the DLP® system board
RESERVED_BB	K4	Output			Do Not Connect on the DLP® system board
RESERVED_BC	X17	Output			Do Not Connect on the DLP® system board
RESERVED_BD	D17	Output			Do Not Connect on the DLP® system board

**Pin Functions - Test Pads**

<b>Pin Number</b>	<b>System Board</b>
E13	Do not connect
C12	Do not connect
D13	Do not connect
C11	Do not connect
E14	Do not connect
E12	Do not connect
C15	Do not connect
D16	Do not connect
W13	Do not connect
Y12	Do not connect
X13	Do not connect
Y11	Do not connect
W14	Do not connect
W12	Do not connect
Y15	Do not connect
X16	Do not connect

## 6 Specifications

### 6.1 Absolute Maximum Ratings

over operating free-air temperature range (unless otherwise noted)

		MIN	MAX	UNIT
<b>Supply Voltages</b>				
$V_{CC}$	Supply voltage for LVCMOS core logic <sup>(1)</sup>	- 0.5	2.3	V
$V_{CCI}$	Supply voltage for LVDS receivers <sup>(1)</sup>	- 0.5	2.3	V
$V_{OFFSET}$	Supply voltage for HVCMOS and micromirror electrode <sup>(1)(2)</sup>	- 0.5	11	V
$V_{BIAS}$	Supply voltage for micromirror electrode <sup>(1)</sup>	- 0.5	19	V
$V_{RESET}$	Supply voltage for micromirror electrode <sup>(1)</sup>	- 15	-0.3	V
$ V_{CC} - V_{CCI} $	Supply voltage delta (absolute value) <sup>(3)</sup>		0.3	V
$ V_{BIAS} - V_{OFFSET} $	Supply voltage delta (absolute value) <sup>(4)</sup>		11	V
$ V_{BIAS} - V_{RESET} $	Supply voltage delta (absolute value) <sup>(5)</sup>		34	V
<b>Input Voltages</b>				
	Input voltage for all other LVCMOS input pins <sup>(1)</sup>	- 0.5	$V_{CC} + 0.5$	V
	Input voltage for all other LVDS input pins <sup>(1)(5)</sup>	- 0.5	$V_{CCI} + 0.5$	V
$ V_{ID} $	Input differential voltage (absolute value) <sup>(5)</sup>		500	mV
$I_{ID}$	Input differential current <sup>(6)</sup>		6.25	mA
<b>Clocks</b>				
$f_{CLOCK}$	Clock frequency for LVDS interface, DCLK_A		400	MHz
$f_{CLOCK}$	Clock frequency for LVDS interface, DCLK_B		400	MHz
$f_{CLOCK}$	Clock frequency for LVDS interface, DCLK_C		400	MHz
$f_{CLOCK}$	Clock frequency for LVDS interface, DCLK_D		400	MHz
<b>Environmental</b>				
$T_{ARRAY}$ and $T_{WINDOW}$	Temperature, operating <sup>(7)</sup>	0	90	°C
Temperature, non-operating <sup>(7)</sup>		- 40	90	°C
$ T_{DELTA} $	Absolute Temperature delta between any point on the window edge and the ceramic test point TP1 <sup>(8)</sup>		30	°C
$T_{DP}$	Dew Point Temperature, operating and non-operating (noncondensing)		81	°C

- (1) All voltages are referenced to common ground  $V_{SS}$ .  $V_{BIAS}$ ,  $V_{CC}$ ,  $V_{CCI}$ ,  $V_{OFFSET}$ , and  $V_{RESET}$  power supplies are all required for proper DMD operation.  $V_{SS}$  must also be connected.
- (2)  $V_{OFFSET}$  supply transients must fall within specified voltages.
- (3) Exceeding the recommended allowable voltage difference between  $V_{CC}$  and  $V_{CCI}$  may result in excessive current draw.
- (4) Exceeding the recommended allowable voltage difference between  $V_{BIAS}$  and  $V_{OFFSET}$  may result in excessive current draw.
- (5) Exceeding the recommended allowable voltage difference between  $V_{BIAS}$  and  $V_{RESET}$  may result in excessive current draw.
- (6) LVDS differential inputs must not exceed the specified limit or damage may result to the internal termination resistors.
- (7) The highest temperature of the active array (as calculated using [Micromirror Array Temperature Calculation](#)) or of any point along the window edge as defined in [Figure 11](#). The locations of thermal test points TP2, TP3, TP4 and TP5 in [Figure 11](#) are intended to measure the highest window edge temperature. If a particular application causes another point on the window edge to be at a higher temperature, that point should be used.
- (8) Temperature delta is the highest difference between the ceramic test point 1 (TP1) and anywhere on the window edge as shown in [Figure 11](#). The window test points TP2, TP3, TP4 and TP5 shown in [Figure 11](#) are intended to result in the worst case delta. If a particular application causes another point on the window edge to result in a larger delta temperature, that point should be used.

## 6.2 Storage Conditions

Applicable for the DMD as a component or non-operating in a system

		MIN	MAX	UNIT
T <sub>stg</sub>	DMD storage temperature	- 40	80	°C
T <sub>DP-AVG</sub>	Average dew point temperature, (non-condensing) <sup>(1)</sup>		28	°C
T <sub>DP-MAX</sub>	Elevated dew point temperature range, (non-condensing) <sup>(2)</sup>	28	36	°C
CT <sub>ELR</sub>	Cumulative time in elevated dew point temperature range		24	Months

- (1) The average over time (including storage and operating) that the device is not in the elevated dew point temperature range.  
 (2) Exposure to dew point temperatures in the elevated range during storage and operation should be limited to less than a total cumulative time of CT<sub>ELR</sub>.

## 6.3 ESD Ratings

		VALUE	UNIT
V <sub>(ESD)</sub>	Electrostatic discharge	Human-body model (HBM), per ANSI/ESDA/JEDEC JS-001 <sup>(1)</sup>	±2000
		Charged device model (CDM), per JEDEC specification JESD22-C101 <sup>(2)</sup>	±500

- (1) JEDEC document JEP155 states that 500-V HBM allows safe manufacturing with a standard ESD control process.  
 (2) JEDEC document JEP157 states that 250-V CDM allows safe manufacturing with a standard ESD control process.

## 6.4 Recommended Operating Conditions

Over operating free-air temperature range (unless otherwise noted). The functional performance of the device specified in this data sheet is achieved when operating the device within the limits defined by the *Recommended Operating Conditions*. No level of performance is implied when operating the device above or below the *Recommended Operating Conditions* limits.

		MIN	NOM	MAX	UNIT
<b>Voltage Supply</b>					
V <sub>CC</sub>	LVC MOS logic supply voltage <sup>(1)</sup>	1.65	1.8	1.95	V
V <sub>CCI</sub>	LVC MOS LVDS Interface supply voltage <sup>(1)</sup>	1.65	1.8	1.95	V
V <sub>OFFSET</sub>	Mirror electrode and HVCMOS voltage <sup>(1)(2)</sup>	9.5	10	10.5	V
V <sub>BIAS</sub>	Mirror electrode voltage <sup>(1)</sup>	17.5	18	18.5	V
V <sub>RESET</sub>	Mirror electrode voltage <sup>(1)</sup>	- 14.5	- 14	- 13.5	V
V <sub>CC</sub> - V <sub>CCI</sub>	Supply voltage delta (absolute value) <sup>(3)</sup>		0	0.3	V
V <sub>BIAS</sub> - V <sub>OFFSET</sub>	Supply voltage delta (absolute value) <sup>(4)</sup>			10.5	V
V <sub>BIAS</sub> - V <sub>RESET</sub>	Supply voltage delta (absolute value) <sup>(5)</sup>			33	V
<b>LVC MOS Interface</b>					
V <sub>IH(DC)</sub>	DC input high voltage <sup>(6)</sup>	0.7 × V <sub>CC</sub>		V <sub>CC</sub> + 0.3	V
V <sub>IL(DC)</sub>	DC input low voltage <sup>(6)</sup>	- 0.3		0.3 × V <sub>CC</sub>	V
V <sub>IH(AC)</sub>	AC input high voltage <sup>(6)</sup>	0.8 × V <sub>CC</sub>		V <sub>CC</sub> + 0.3	V
V <sub>IL(AC)</sub>	AC input low voltage <sup>(6)</sup>	- 0.3		0.2 × V <sub>CC</sub>	V
t <sub>PWRDNZ</sub>	PWRDNZ pulse width <sup>(7)</sup>	10			ns
<b>SCP Interface</b>					
f <sub>SCPCLK</sub>	SCP clock frequency <sup>(8)</sup>			500	kHz
t <sub>SCP_PD</sub>	Propagation delay, Clock to Q, from rising-edge of SCPCLK to valid SCPDO <sup>(9)</sup>	0		900	ns
t <sub>SCP_NEG_ENZ</sub>	Time between falling-edge of SCPENZ and the first rising-edge of SCPCLK	2			µs

- (1) All voltages are referenced to common ground VSS. VBIAS, VCC, VCCI, VOFFSET, and VRESET power supplies are all required for proper DMD operation. VSS must also be connected.  
 (2) VOFFSET supply transients must fall within specified max voltages.  
 (3) To prevent excess current, the supply voltage delta |VCCI - VCC| must be less than specified limit. See *Power Supply Recommendations*, Figure 15, and Table 8.  
 (4) To prevent excess current, the supply voltage delta |VBIAS - VOFFSET| must be less than specified limit. See *Power Supply Recommendations*, Figure 15, and Table 8.  
 (5) To prevent excess current, the supply voltage delta |VBIAS - VRESET| must be less than specified limit. See *Power Supply Recommendations*, Figure 15, and Table 8.  
 (6) Low-speed interface is LPSDR and adheres to the Electrical Characteristics and AC/DC Operating Conditions table in JEDEC Standard No. 209B, "Low-Power Double Data Rate (LPDDR)" JESD209B. Tester Conditions for VIH and VIL.  
 (a) Frequency = 60 MHz. Maximum Rise Time = 2.5 ns @ (20% - 80%)  
 (b) Frequency = 60 MHz. Maximum Fall Time = 2.5 ns @ (80% - 20%)  
 (7) PWRDNZ input pin resets the SCP and disables the LVDS receivers. PWRDNZ input pin overrides SCPENZ input pin and tristates the SCPDO output pin.  
 (8) The SCP clock is a gated clock. Duty cycle must be 50% ± 10%. SCP parameter is related to the frequency of DCLK.  
 (9) See Figure 2.

## Recommended Operating Conditions (continued)

Over operating free-air temperature range (unless otherwise noted). The functional performance of the device specified in this data sheet is achieved when operating the device within the limits defined by the [Recommended Operating Conditions](#). No level of performance is implied when operating the device above or below the [Recommended Operating Conditions](#) limits.

		MIN	NOM	MAX	UNIT
$t_{SCP\_POS\_ENZ}$	Time between falling-edge of SCPCLK and the rising-edge of SCPENZ	2			$\mu$ s
$t_{SCP\_DS}$	SCPDI Clock Setup time (before SCPCLK falling edge) <sup>(9)</sup>	800			ns
$t_{SCP\_DH}$	SCPDI Hold time (after SCPCLK falling edge) <sup>(9)</sup>	900			ns
$t_{SCP\_PW\_ENZ}$	SCPENZ inactive pulse width (high level)	2			$\mu$ s
<b>LVDS Interface</b>					
$f_{CLOCK}$	Clock frequency for LVDS interface (all channels), DCLK <sup>(10)</sup>			400	MHz
$ V_{ID} $	Input differential voltage (absolute value) <sup>(11)</sup>	150	300	440	mV
$V_{CM}$	Common mode voltage <sup>(11)</sup>	1100	1200	1300	mV
$V_{LVDS}$	LVDS voltage <sup>(11)</sup>	880		1520	mV
$t_{LVDS\_RSTZ}$	Time required for LVDS receivers to recover from PWRDNZ			2000	ns
$Z_{IN}$	Internal differential termination resistance	80	100	120	$\Omega$
$Z_{LINE}$	Line differential impedance (PWB/trace)	90	100	110	$\Omega$
<b>Environmental</b>					
$T_{ARRAY}$	Array temperature, Long-term operational <sup>(12)(13)(14)(15)</sup>	10		40 to 70 <sup>(14)</sup>	$^{\circ}$ C
	Array temperature, Short-term operational <sup>(13)(16)</sup>	0		10	$^{\circ}$ C
$T_{WINDOW}$	Window temperature – operational			85	$^{\circ}$ C
$ T_{\Delta} $	Absolute Temperature delta between any point on the window edge and the ceramic test point TP1 <sup>(17)(18)</sup>			14	$^{\circ}$ C
$T_{DP\_AVG}$	Average dew point average temperature (non-condensing) <sup>(19)</sup>			28	$^{\circ}$ C
$T_{DP\_MAX}$	Elevated dew point temperature range (non-condensing) <sup>(20)</sup>	28		36	$^{\circ}$ C
$CT_{ELR}$	Cumulative time in elevated dew point temperature range			24	Months
L	Operating system luminance <sup>(18)</sup>			7000	lm
$ILL_{UV}$	Illumination Wavelengths < 395 nm <sup>(12)(21)</sup>		0.68	2.00	mW/cm <sup>2</sup>
$ILL_{VIS}$	Illumination Wavelengths between 395 nm and 800 nm <sup>(21)</sup>		Thermally limited		mW/cm <sup>2</sup>
$ILL_{IR}$	Illumination Wavelengths > 800 nm <sup>(21)</sup>			10	mW/cm <sup>2</sup>

(10) See LVDS Timing Requirements in [Timing Requirements](#) and [Figure 6](#).

(11) See [Figure 5](#) LVDS Waveform Requirements.

(12) Simultaneous exposure of the DMD to the maximum [Recommended Operating Conditions](#) for temperature and UV illumination will reduce device lifetime.

(13) The array temperature cannot be measured directly and must be computed analytically from the temperature measured at test point 1 (TP1) shown in [Figure 11](#) and the package thermal resistance [Micromirror Array Temperature Calculation](#).

(14) Per [Figure 1](#), the maximum operational array temperature should be derated based on the micromirror landed duty cycle that the DMD experiences in the end application. See [Micromirror Landed-On/Landed-Off Duty Cycle](#) for a definition of micromirror landed duty cycle.

(15) Long-term is defined as the usable life of the device.

(16) Array temperatures beyond those specified as long-term are recommended for short-term conditions only (power-up). Short-term is defined as cumulative time over the usable life of the device and is less than 500 hours.

(17) Temperature delta is the highest difference between the ceramic test point 1 (TP1) and anywhere on the window edge as shown in [Figure 11](#). The window test points TP2, TP3, TP4 and TP5 shown in [Figure 11](#) are intended to result in the worst case delta temperature. If a particular application causes another point on the window edge to result in a larger delta temperature, that point should be used.

(18) DMD is qualified at the combination of the maximum temperature and maximum lumens specified. Operation of the DMD outside of these limits has not been tested.

(19) The average over time (including storage and operating) that the device is not in the elevated dew point temperature range.

(20) Exposure to dew point temperatures in the elevated range during storage and operation should be limited to less than a total cumulative time of  $CT_{ELR}$ .

(21) Supported for Video applications only

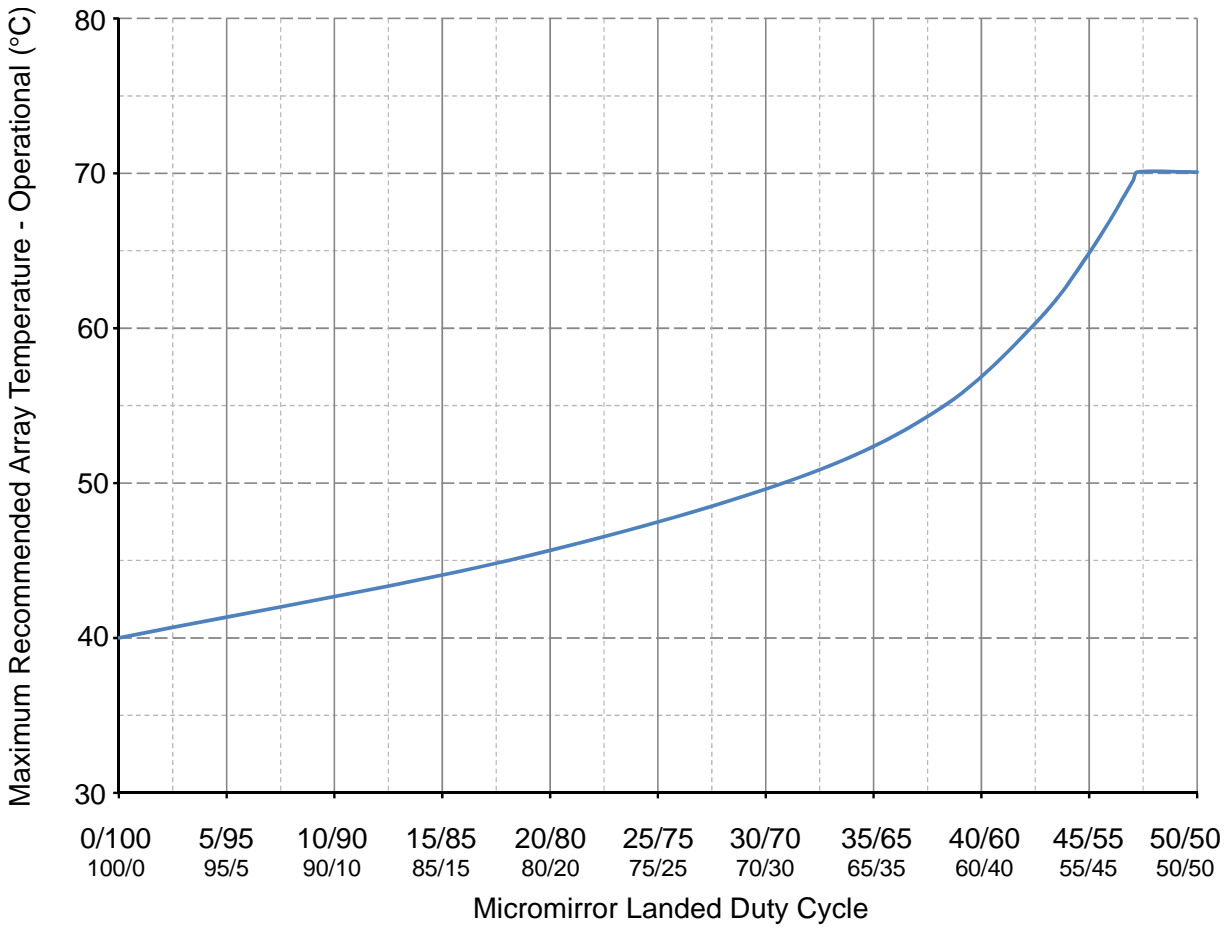

**Figure 1. Max Recommended Array Temperature - Derating Curve**

## 6.5 Thermal Information

THERMAL METRIC	DLP660TE	UNIT
	FYG Package	
	350 PINS	
Thermal resistance, active area to test point 1 (TP1) <sup>(1)</sup>	0.60	°C/W

- (1) The DMD is designed to conduct absorbed and dissipated heat to the back of the package. The cooling system must be capable of maintaining the package within the temperature range specified in the [Recommended Operating Conditions](#). The total heat load on the DMD is largely driven by the incident light absorbed by the active area; although other contributions include light energy absorbed by the window aperture and electrical power dissipation of the array. Optical systems should be designed to minimize the light energy falling outside the window clear aperture since any additional thermal load in this area can significantly degrade the reliability of the device.

## 6.6 Electrical Characteristics

Over operating free-air temperature range (unless otherwise noted)

PARAMETER	TEST CONDITIONS	MIN	TYP	MAX	UNIT
V <sub>OH</sub>	High level output voltage V <sub>CC</sub> = 1.8 V, I <sub>OH</sub> = - 2 mA	0.8 x V <sub>CC</sub>			V
V <sub>OL</sub>	Low level output voltage V <sub>CC</sub> = 1.95 V, I <sub>OL</sub> = 2 mA	0.2 x V <sub>CC</sub>			V
I <sub>OZ</sub>	High impedance output current V <sub>CC</sub> = 1.95 V	-40		25	µA
I <sub>IL</sub>	Low level input current V <sub>CC</sub> = 1.95 V, V <sub>I</sub> = 0	-1			µA
I <sub>IH</sub>	High level input current <sup>(1)</sup> V <sub>CC</sub> = 1.95 V, V <sub>I</sub> = V <sub>CC</sub>			110	µA
I <sub>CC</sub>	Supply current VCC V <sub>CC</sub> = 1.95 V			1200	mA
I <sub>CCI</sub>	Supply current VCCI V <sub>CCI</sub> = 1.95 V			330	mA
I <sub>OFFSET</sub>	Supply current VOFFSET <sup>(2)</sup> V <sub>OFFSET</sub> = 10.5 V			13.2	mA
I <sub>BIAS</sub>	Supply current VBIAS <sup>(2)</sup> <sup>(3)</sup> V <sub>BIAS</sub> = 18.5 V			-3.641	mA
I <sub>RESET</sub>	Supply current VRESET <sup>(3)</sup> V <sub>RESET</sub> = - 14.5 V			9.02	mA
Supply power dissipation Total				3320.25	mW

- (1) Applies to LVCMOS pins only. Excludes LVDS pins and test pad pins.

- (2) To prevent excess current, the supply voltage delta |V<sub>BIAS</sub> – V<sub>OFFSET</sub>| must be less than the specified limit in [Recommended Operating Conditions](#).

- (3) To prevent excess current, the supply voltage delta |V<sub>BIAS</sub> – V<sub>RESET</sub>| must be less than specified limit in [Recommended Operating Conditions](#).

## 6.7 Capacitance at Recommended Operating Conditions

over operating free-air temperature range (unless otherwise noted)

PARAMETER	TEST CONDITIONS	MIN	TYP	MAX	UNIT
C <sub>I_lvds</sub>	LVDS Input Capacitance 2xLVDS f = 1 MHz			20	pF
C <sub>I_nonlvds</sub>	Non-LVDS Input capacitance 2xLVDS f = 1 MHz			20	pF
C <sub>I_tdiode</sub>	Temp Diode Input capacitance 2xLVDS f = 1 MHz			30	pF
C <sub>O</sub>	Output Capacitance f = 1 MHz			20	pF

## 6.8 Timing Requirements

			MIN	NOM	MAX	UNIT
<b>SCP<sup>(1)</sup></b>						
$t_r$	Rise slew rate	20% to 80% reference points	1		3	V/ns
$t_f$	Fall slew rate	80% to 20% reference points	1		3	V/ns
<b>LVDS<sup>(2)</sup></b>						
$t_r$	Rise slew rate	20% to 80% reference points	0.7	1		V/ns
$t_f$	Fall slew rate	80% to 20% reference points	0.7	1		V/ns
$t_C$	Clock Cycle	DCLK_A, LVDS pair	2.5			ns
$t_C$	Clock Cycle	DCLK_B, LVDS pair	2.5			ns
$t_C$	Clock Cycle	DCLK_C, LVDS pair	2.5			ns
$t_C$	Clock Cycle	DCLK_D, LVDS pair	2.5			ns
$t_W$	Pulse Width	DCLK_A LVDS pair	1.19	1.25		ns
$t_W$	Pulse Width	DCLK_B LVDS pair	1.19	1.25		ns
$t_W$	Pulse Width	DCLK_C LVDS pair	1.19	1.25		ns
$t_W$	Pulse Width	DCLK_D LVDS pair	1.19	1.25		ns
$t_{Su}$	Setup Time	D_A(15:0) before DCLK_A, LVDS pair	0.325			ns
$t_{Su}$	Setup Time	D_B(15:0) before DCLK_B, LVDS pair	0.325			ns
$t_{Su}$	Setup Time	D_C(15:0) before DCLK_C, LVDS pair	0.325			ns
$t_{Su}$	Setup Time	D_D(15:0) before DCLK_D, LVDS pair	0.325			ns
$t_{Su}$	Setup Time	SCTRL_A before DCLK_A, LVDS pair	0.325			ns
$t_{Su}$	Setup Time	SCTRL_B before DCLK_B, LVDS pair	0.325			ns
$t_{Su}$	Setup Time	SCTRL_C before DCLK_C, LVDS pair	0.325			ns
$t_{Su}$	Setup Time	SCTRL_D before DCLK_D, LVDS pair	0.325			ns
$t_h$	Hold Time	D_A(15:0) after DCLK_A, LVDS pair	0.145			ns
$t_h$	Hold Time	D_B(15:0) after DCLK_B, LVDS pair	0.145			ns
$t_h$	Hold Time	D_C(15:0) after DCLK_C, LVDS pair	0.145			ns
$t_h$	Hold Time	D_D(15:0) after DCLK_D, LVDS pair	0.145			ns
$t_h$	Hold Time	SCTRL_A after DCLK_A, LVDS pair	0.145			ns
$t_h$	Hold Time	SCTRL_B after DCLK_B, LVDS pair	0.145			ns
$t_h$	Hold Time	SCTRL_C after DCLK_C, LVDS pair	0.145			ns
$t_h$	Hold Time	SCTRL_D after DCLK_D, LVDS pair	0.145			ns
<b>LVDS<sup>(2)</sup></b>						
$t_{SKEW}$	Skew Time	Channel B relative to Channel A <sup>(3)(4)</sup> , LVDS pair	-1.25		+1.25	ns
$t_{SKEW}$	Skew Time	Channel D relative to Channel C <sup>(5)(6)</sup> , LVDS pair	-1.25		+1.25	ns

(1) See [Figure 3](#) for Rise Time and Fall Time for SCP.

(2) See [Figure 5](#) for Timing Requirements for LVDS.

(3) Channel A (Bus A) includes the following LVDS pairs: DCLK\_AN and DCLK\_AP, SCTRL\_AN and SCTRL\_AP, D\_AN(15:0) and D\_AP(15:0).

(4) Channel B (Bus B) includes the following LVDS pairs: DCLK\_BN and DCLK\_BP, SCTRL\_BN and SCTRL\_BP, D\_BN(15:0) and D\_BP(15:0).

(5) Channel C (Bus C) includes the following LVDS pairs: DCLK\_CN and DCLK\_CP, SCTRL\_CN and SCTRL\_CP, D\_CN(15:0) and D\_CP(15:0).

(6) Channel D (Bus D) includes the following LVDS pairs: DCLK\_DN and DCLK\_DP, SCTRL\_DN and SCTRL\_DP, D\_DN(15:0) and D\_DP(15:0).



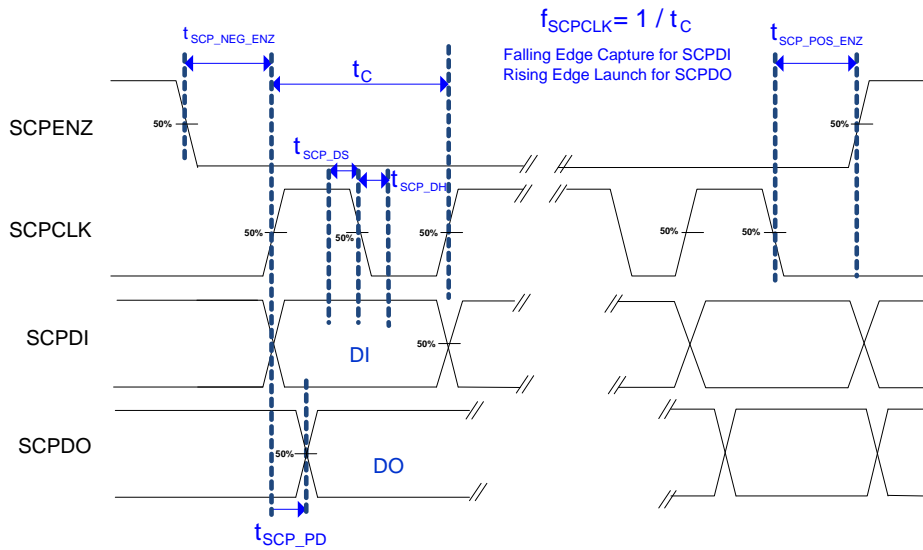

Figure 2. SCP Timing Requirements

See [Recommended Operating Conditions](#) for  $f_{SCPCLK}$ ,  $t_{SCP\_DS}$ ,  $t_{SCP\_DH}$  and  $t_{SCP\_PD}$  specifications.

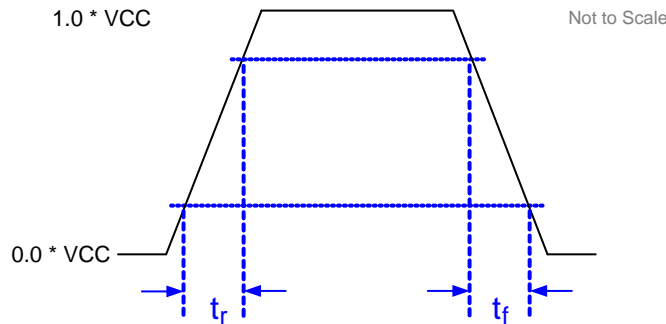

Figure 3. SCP Requirements for Rise and Fall

See [Timing Requirements](#) for  $t_r$  and  $t_f$  specifications and conditions.

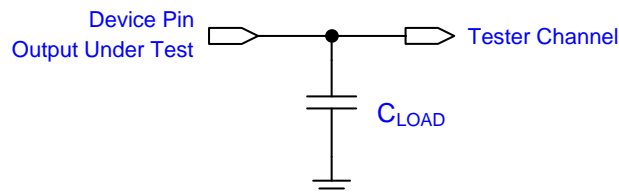
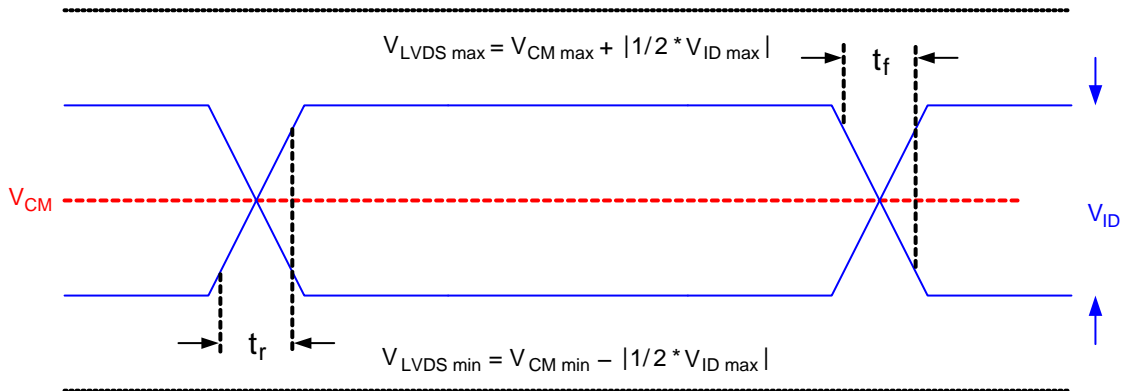

Figure 4. Test Load Circuit for Output Propagation Measurement

For output timing analysis, the tester pin electronics and its transmission line effects must be taken into account. System designers should use IBIS or other simulation tools to correlate the timing reference load to a system environment.

Not to Scale



**Figure 5. LVDS Waveform Requirements**

See *Recommended Operating Conditions* for  $V_{CM}$ ,  $V_{ID}$ , and  $V_{LVDS}$  specifications and conditions.

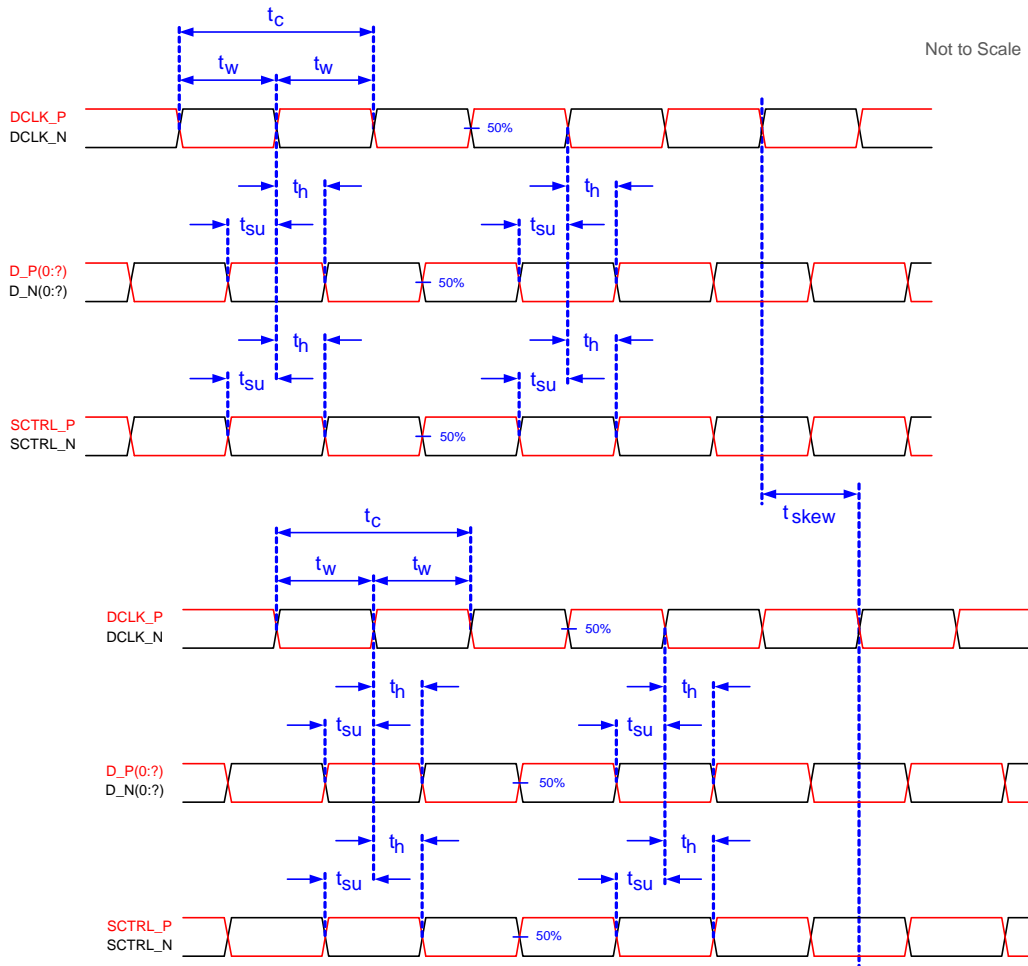

**Figure 6. Timing Requirements**

See *Timing Requirements* for timing requirements and LVDS pairs per channel (bus) defining D\_P(0:x) and D\_N(0:x).

## 6.9 System Mounting Interface Loads

Table 1. System Mounting Interface Loads

PARAMETER		MIN	NOM	MAX	UNIT
Thermal interface area	Condition 1: Maximum load of 22.6 kg evenly distributed within each area below: <sup>(1)</sup>			11.3	kg
Electrical interface area				11.3	kg
Thermal interface area	Condition 2: Maximum load of 22.6 kg evenly distributed within each area below: <sup>(1)</sup>			0	kg
Electrical interface area				22.6	kg

(1) See Figure 7.

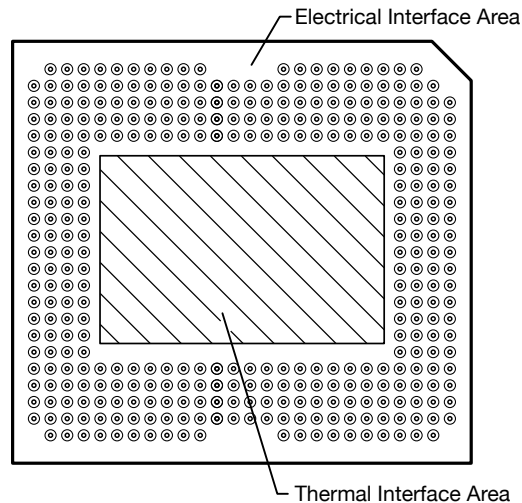

Figure 7. System Mounting Interface Loads

## 6.10 Micromirror Array Physical Characteristics

Table 2. Micromirror Array Physical Characteristics

PARAMETER DESCRIPTION		VALUE	UNIT
Number of active columns <sup>(1)</sup>	M	2716	micromirrors
Number of active rows <sup>(1)</sup>	N	1528	micromirrors
Micromirror (pixel) pitch <sup>(1)</sup>	P	5.4	μm
Micromirror active array width <sup>(1)</sup>	Micromirror Pitch × number of active columns	14.67	mm
Micromirror active array height <sup>(1)</sup>	Micromirror Pitch × number of active rows	8.25	mm
Micromirror active border (Top / Bottom) <sup>(2)</sup>	Pond of micromirrors (POM)	56	micromirrors / side
Micromirror active border (Right / Left) <sup>(2)</sup>	Pond of micromirrors (POM)	20	micromirrors / side

(1) See Figure 8.

(2) The structure and qualities of the border around the active array includes a band of partially functional micromirrors called the “Pond Of Mirrors” (POM). These micromirrors are structurally and/or electrically prevented from tilting toward the bright or “on” state but still require an electrical bias to tilt toward “off.”

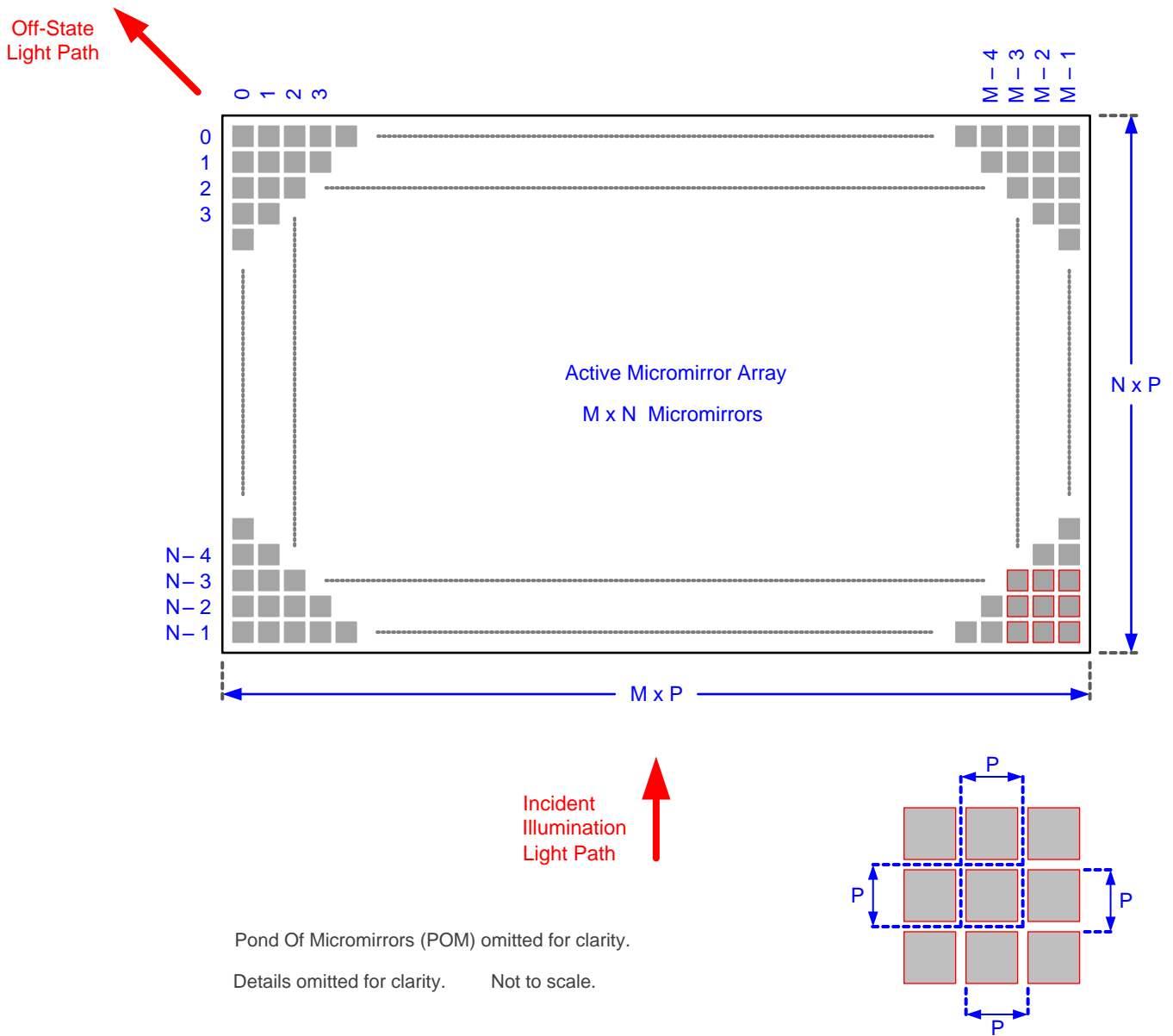

**Figure 8. Micromirror Array Physical Characteristics**

Refer to section [Micromirror Array Physical Characteristics](#) table for M, N, and P specifications.

### 6.11 Micromirror Array Optical Characteristics

**Table 3. Micromirror Array Optical Characteristics**

PARAMETER		MIN	NOM	MAX	UNIT
Mirror Tilt angle, variation device to device <sup>(1)</sup> <sup>(2)</sup>		15.6	17.0	18.4	degrees
Number of out-of-specification micromirrors <sup>(3)</sup>	Adjacent micromirrors	0			micromirrors
	Non-Adjacent micromirrors	10			

- (1) Limits on variability of micromirror tilt angle are critical in the design of the accompanying optical system. Variations in tilt angle within a device may result in apparent non-uniformities, such as line pairing and image mottling, across the projected image. Variations in the average tilt angle between devices may result in colorimetric and system contrast variations.
- (2) See [Figure 9](#).
- (3) An out-of-specification micromirror is defined as a micromirror that is unable to transition between the two landed states within the specified Micromirror Switching Time.

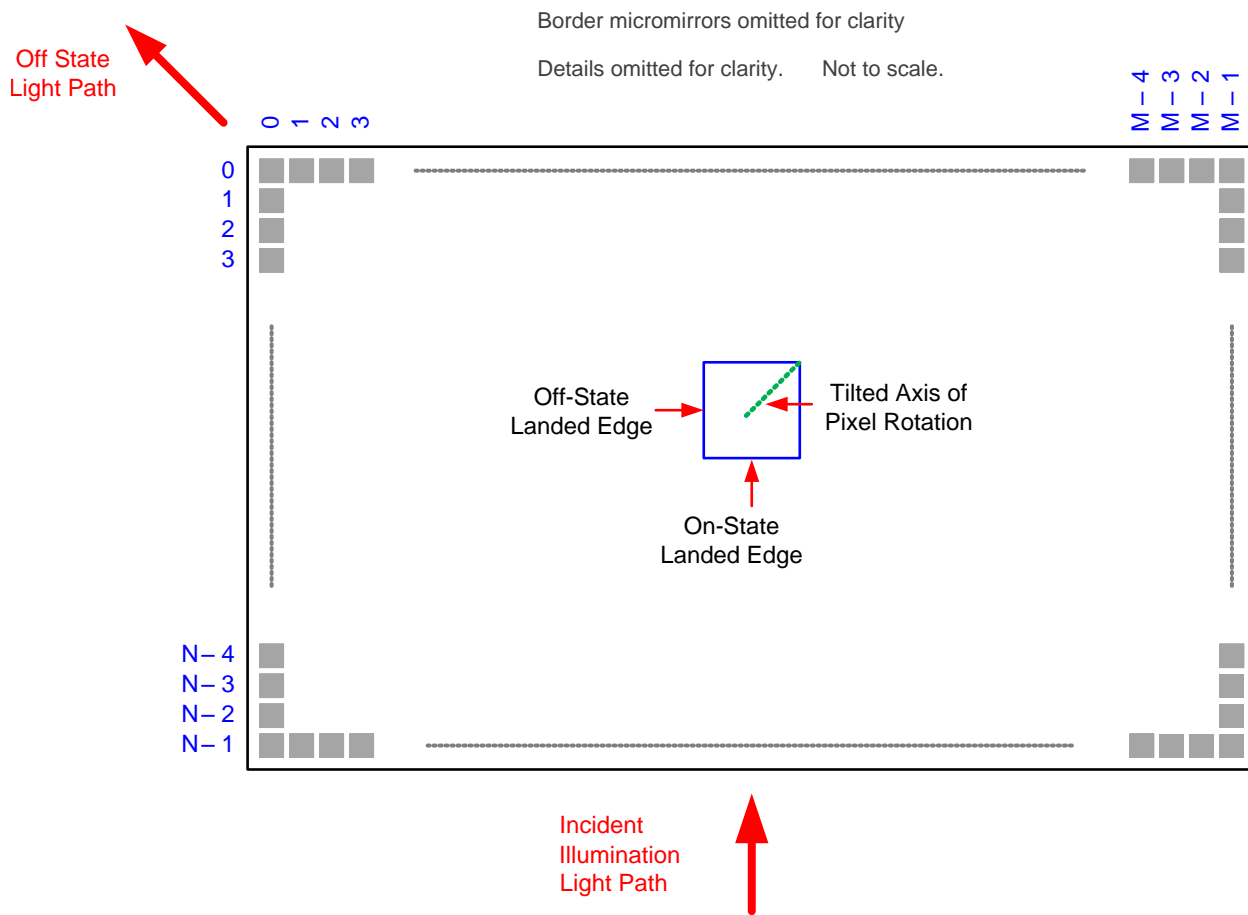

**Figure 9. Micromirror Landed Orientation and Tilt**

Refer to section [Micromirror Array Physical Characteristics](#) table for M, N, and P specifications.

## 6.12 Window Characteristics

**Table 4. DMD Window Characteristics**

PARAMETER	MIN	NOM	MAX	UNIT
Window Material Designation S610		Corning Eagle XG		
Window Refractive Index at 546.1 nm		1.5119		
Window Transmittance, minimum within the wavelength range 420–680 nm. Applies to all angles 0–30° AOI. <sup>(1)</sup> <sup>(2)</sup>	97%			
Window Transmittance, average over the wavelength range 420–680 nm. Applies to all angles 30–45° AOI. <sup>(1)</sup> <sup>(2)</sup>	97%			

(1) Single-pass through both surfaces and glass.

(2) AOI – angle of incidence is the angle between an incident ray and the normal to a reflecting or refracting surface.

## 6.13 Chipset Component Usage Specification

Reliable function and operation of the DLP660TE DMD requires that it be used in conjunction with the other components of the applicable DLP chipset, including those components that contain or implement TI DMD control technology. TI DMD control technology is the TI technology and devices for operating or controlling a DLP DMD.

## 7 Detailed Description

### 7.1 Overview

The DMD is a 0.66 inch diagonal spatial light modulator which consists of an array of highly reflective aluminum micromirrors. The DMD is an electrical input, optical output micro-electrical-mechanical system (MEMS). The electrical interface is Low Voltage Differential Signaling (LVDS). The DMD consists of a two-dimensional array of 1-bit CMOS memory cells. The array is organized in a grid of M memory cell columns by N memory cell rows. Refer to the [Functional Block Diagram](#). The positive or negative deflection angle of the micromirrors can be individually controlled by changing the address voltage of underlying CMOS addressing circuitry and micromirror reset signals (MBRST).

The DLP660TE DMD is part of the chipset comprising of the DLP660TE DMD, the DLPC4422 display controller and the DLPA100 power and motor driver. To ensure reliable operation, the DLP660TE DMD must always be used with the DLPC4422 display controller and the DLPA100 power and motor driver.

### 7.2 Functional Block Diagram

Not to Scale. Details Omitted for Clarity. See Accompanying Notes in this Section.

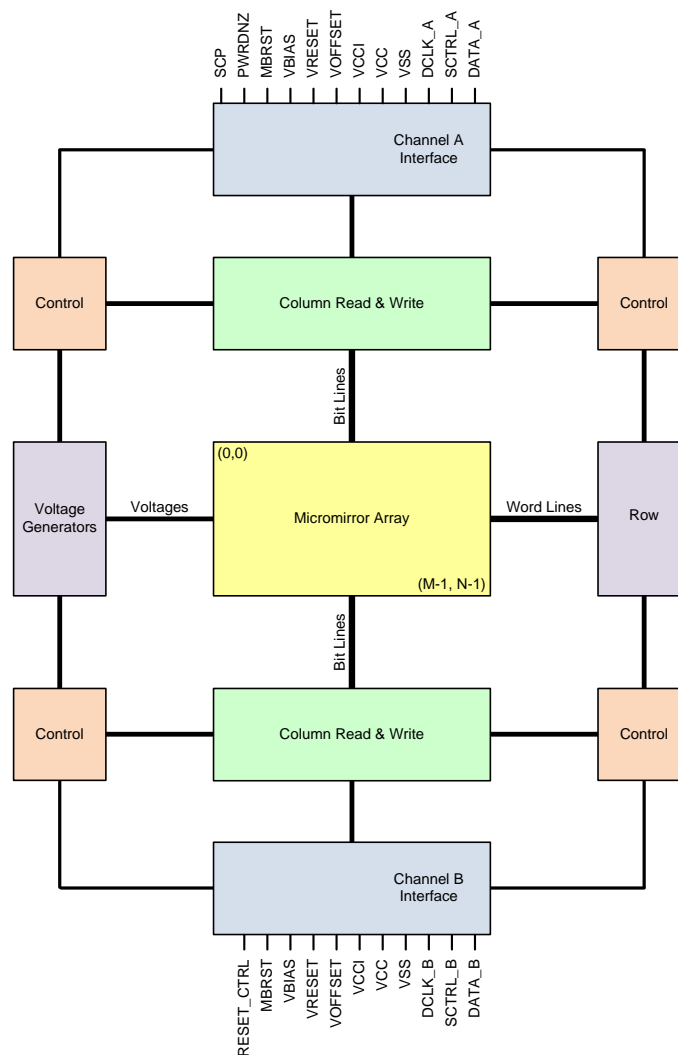

For pin details on Channels A, B, C, and D, refer to [Pin Configurations and Functions](#) and [LVDS Interface](#) section of [Timing Requirements](#).

**Figure 10. Functional Block Diagram**

## 7.3 Feature Description

### 7.3.1 Power Interface

The DMD requires 5 DC voltages: DMD\_P3P3V, DMD\_P1P8V, VOFFSET, VRESET, and VBIAS. DMD\_P3P3V is created by the DLPA100 power and motor driver and is used on the DMD board to create the other 4 DMD voltages, as well as powering various peripherals (TMP411, I2C, and TI level translators). DMD\_P1P8V is created by the TI PMIC LP38513S and provides the VCC voltage required by the DMD. VOFFSET (10V), VRESET (-14V), and VBIAS(18V) are made by the TI PMIC TPS65145 and are supplied to the DMD to control the micromirrors.

### 7.3.2 Timing

The data sheet provides timing at the device pin. For output timing analysis, the tester pin electronics and its transmission line effects must be taken into account. [Figure 4](#) shows an equivalent test load circuit for the output under test. Timing reference loads are not intended as a precise representation of any particular system environment or depiction of the actual load presented by a production test. System designers should use IBIS or other simulation tools to correlate the timing reference load to a system environment. The load capacitance value stated is only for characterization and measurement of AC timing signals. This load capacitance value does not indicate the maximum load the device is capable of driving.

## 7.4 Device Functional Modes

DMD functional modes are controlled by the DLPC4422 display controller. See the DLPC4422 display controller data sheet or contact a TI applications engineer.

## 7.5 Optical Interface and System Image Quality Considerations

### 7.5.1 Optical Interface and System Image Quality

TI assumes no responsibility for end-equipment optical performance. Achieving the desired end-equipment optical performance involves making trade-offs between numerous component and system design parameters. Optimizing system optical performance and image quality strongly relate to optical system design parameter trades. Although it is not possible to anticipate every conceivable application, projector image quality and optical performance is contingent on compliance to the optical system operating conditions described in the following sections.

#### 7.5.1.1 Numerical Aperture and Stray Light Control

The angle defined by the numerical aperture of the illumination and projection optics at the DMD optical area should be the same. This angle should not exceed the nominal device micromirror tilt angle unless appropriate apertures are added in the illumination and/or projection pupils to block out flat-state and stray light from the projection lens. The micromirror tilt angle defines DMD capability to separate the "ON" optical path from any other light path, including undesirable flat-state specular reflections from the DMD window, DMD border structures, or other system surfaces near the DMD such as prism or lens surfaces. If the numerical aperture exceeds the micromirror tilt angle, or if the projection numerical aperture angle is more than two degrees larger than the illumination numerical aperture angle, objectionable artifacts in the display's border and/or active area could occur.

#### 7.5.1.2 Pupil Match

TI's optical and image quality specifications assume that the exit pupil of the illumination optics is nominally centered within 2° of the entrance pupil of the projection optics. Misalignment of pupils can create objectionable artifacts in the display's border and/or active area, which may require additional system apertures to control, especially if the numerical aperture of the system exceeds the pixel tilt angle.



## Optical Interface and System Image Quality Considerations (continued)

### 7.5.1.3 Illumination Overfill

The active area of the device is surrounded by an aperture on the inside DMD window surface that masks structures of the DMD chip assembly from normal view, and is sized to anticipate several optical operating conditions. Overfill light illuminating the window aperture can create artifacts from the edge of the window aperture opening and other surface anomalies that may be visible on the screen. The illumination optical system should be designed to limit light flux incident anywhere on the window aperture from exceeding approximately 10% of the average flux level in the active area. Depending on the particular system's optical architecture, overfill light may have to be further reduced below the suggested 10% level in order to be acceptable.

## 7.6 Micromirror Array Temperature Calculation

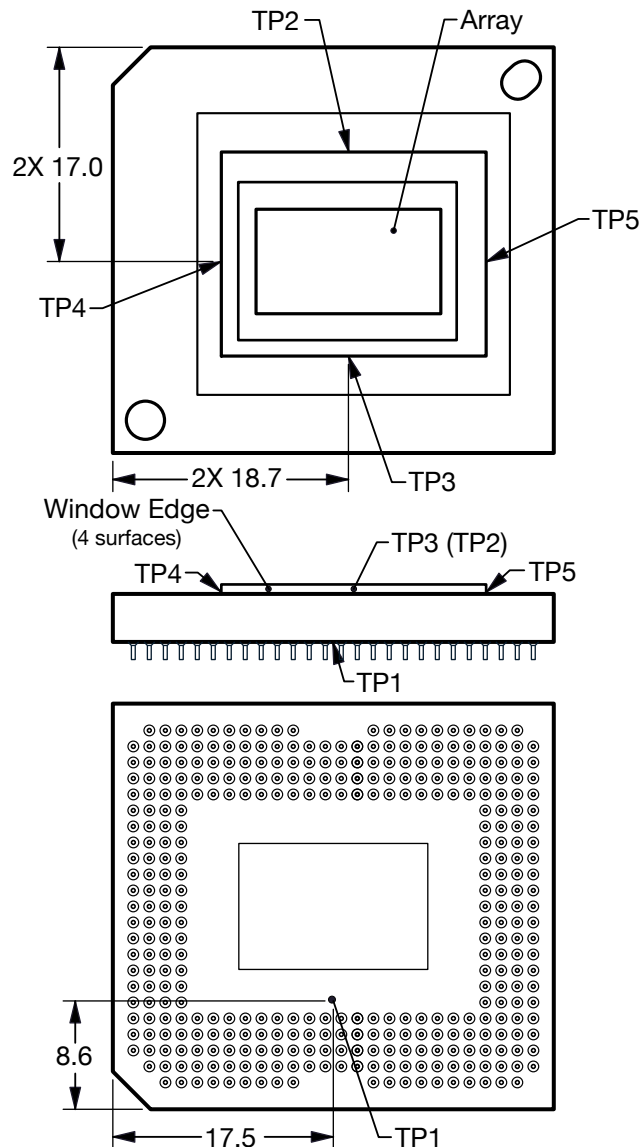

Figure 11. DMD Thermal Test Points

## Micromirror Array Temperature Calculation (continued)

Micromirror array temperature can be computed analytically from measurement points on the outside of the package, the package thermal resistance, the electrical power, and the illumination heat load. The relationship between micromirror array temperature and the reference ceramic temperature is provided by the following equations:

$$T_{\text{ARRAY}} = T_{\text{CERAMIC}} + (Q_{\text{ARRAY}} \times R_{\text{ARRAY-TO-CERAMIC}})$$

$$Q_{\text{ARRAY}} = Q_{\text{ELECTRICAL}} + Q_{\text{ILLUMINATION}}$$

where

- $T_{\text{ARRAY}}$  = computed array temperature (°C)
- $T_{\text{CERAMIC}}$  = measured ceramic temperature (°C) (TP1 location)
- $R_{\text{ARRAY-TO-CERAMIC}}$  = thermal resistance of package from array to ceramic TP1 (°C/Watt)
- $Q_{\text{ARRAY}}$  = Total DMD power on the array (Watts) (electrical + absorbed)
- $Q_{\text{ELECTRICAL}}$  = nominal electrical power
- $Q_{\text{ILLUMINATION}} = (C_{\text{L2W}} \times \text{SL})$
- $C_{\text{L2W}}$  = Conversion constant for screen lumens to power on DMD (Watts/Lumen)
- $\text{SL}$  = measured screen lumens

The electrical power dissipation of the DMD is variable and depends on the voltages, data rates and operating frequencies. A nominal electrical power dissipation to use when calculating array temperature is 3.0 Watts. The absorbed power from the illumination source is variable and depends on the operating state of the micromirrors and the intensity of the light source. The equations shown above are valid for a 1-Chip DMD system with projection efficiency from the DMD to the screen of 87%.

The conversion constant  $C_{\text{L2W}}$  is based on array characteristics. It assumes a spectral efficiency of 300 lumens/Watt for the projected light and illumination distribution of 83.7% on the active array, and 16.3% on the array border.

Sample calculations for typical projection application:

$$Q_{\text{ELECTRICAL}} = 3.0 \text{ W}$$

$$C_{\text{L2W}} = 0.00266$$

$$\text{SL} = 5000 \text{ lm}$$

$$T_{\text{CERAMIC}} = 55.0^\circ\text{C}$$

$$Q_{\text{ARRAY}} = 3.0 \text{ W} + (0.00266 \times 5000 \text{ lm}) = 16.3 \text{ W}$$

$$T_{\text{ARRAY}} = 55.0^\circ\text{C} + (16.3 \text{ W} \times 0.60^\circ\text{C/W}) = 64.78^\circ\text{C}$$

## 7.7 Micromirror Landed-On/Landed-Off Duty Cycle

### 7.7.1 Definition of Micromirror Landed-On/Landed-Off Duty Cycle

The micromirror landed-on/landed-off duty cycle (landed duty cycle) denotes the amount of time (as a percentage) that an individual micromirror is landed in the On state versus the amount of time the same micromirror is landed in the Off state.

As an example, a landed duty cycle of 100/0 indicates that the referenced pixel is in the On state 100% of the time (and in the Off state 0% of the time); whereas 0/100 would indicate that the pixel is in the Off state 100% of the time. Likewise, 50/50 indicates that the pixel is On 50% of the time and Off 50% of the time.

Note that when assessing landed duty cycle, the time spent switching from one state (ON or OFF) to the other state (OFF or ON) is considered negligible and is thus ignored.

Since a micromirror can only be landed in one state or the other (On or Off), the two numbers (percentages) always add to 100.

## Micromirror Landed-On/Landed-Off Duty Cycle (continued)

### 7.7.2 Landed Duty Cycle and Useful Life of the DMD

Knowing the long-term average landed duty cycle (of the end product or application) is important because subjecting all (or a portion) of the DMD's micromirror array (also called the active array) to an asymmetric landed duty cycle for a prolonged period of time can reduce the DMD's usable life.

Note that it is the symmetry/asymmetry of the landed duty cycle that is of relevance. The symmetry of the landed duty cycle is determined by how close the two numbers (percentages) are to being equal. For example, a landed duty cycle of 50/50 is perfectly symmetrical whereas a landed duty cycle of 100/0 or 0/100 is perfectly asymmetrical.

### 7.7.3 Landed Duty Cycle and Operational DMD Temperature

Operational DMD Temperature and Landed Duty Cycle interact to affect the DMD's usable life, and this interaction can be exploited to reduce the impact that an asymmetrical Landed Duty Cycle has on the DMD's usable life. This is quantified in the de-rating curve shown in [Figure 1](#). The importance of this curve is that:

- All points along this curve represent the same usable life.
- All points above this curve represent lower usable life (and the further away from the curve, the lower the usable life).
- All points below this curve represent higher usable life (and the further away from the curve, the higher the usable life).

In practice, this curve specifies the Maximum Operating DMD Temperature that the DMD should be operated at for a given long-term average Landed Duty Cycle.

### 7.7.4 Estimating the Long-Term Average Landed Duty Cycle of a Product or Application

During a given period of time, the Landed Duty Cycle of a given pixel follows from the image content being displayed by that pixel.

For example, in the simplest case, when displaying pure-white on a given pixel for a given time period, that pixel will experience a 100/0 Landed Duty Cycle during that time period. Likewise, when displaying pure-black, the pixel will experience a 0/100 Landed Duty Cycle.

Between the two extremes (ignoring for the moment color and any image processing that may be applied to an incoming image), the Landed Duty Cycle tracks one-to-one with the gray scale value, as shown in [Table 5](#).

**Table 5. Grayscale Value and Landed Duty Cycle**

Grayscale Value	Landed Duty Cycle
0%	0/100
10%	10/90
20%	20/80
30%	30/70
40%	40/60
50%	50/50
60%	60/40
70%	70/30
80%	80/20
90%	90/10
100%	100/0

Accounting for color rendition (but still ignoring image processing) requires knowing both the color intensity (from 0% to 100%) for each constituent primary color (red, green, and/or blue) for the given pixel as well as the color cycle time for each primary color, where “color cycle time” is the total percentage of the frame time that a given primary must be displayed in order to achieve the desired white point.

During a given period of time, the landed duty cycle of a given pixel can be calculated as follows:

- Landed Duty Cycle = (Red\_Cycle\_% × Red\_Scale\_Value) + (Green\_Cycle\_% × Green\_Scale\_Value) + (Blue\_Cycle\_% × Blue\_Scale\_Value)

Where

- Red\_Cycle\_%, Green\_Cycle\_%, and Blue\_Cycle\_%, represent the percentage of the frame time that Red, Green, and Blue are displayed (respectively) to achieve the desired white point. (1)

For example, assume that the red, green and blue color cycle times are 50%, 20%, and 30% respectively (in order to achieve the desired white point), then the Landed Duty Cycle for various combinations of red, green, blue color intensities would be as shown in [Table 6](#) and [Table 7](#).

**Table 6. Example Landed Duty Cycle for Full-Color, Color Percentage**

Red Cycle Percentage	Green Cycle Percentage	Blue Cycle Percentage
50%	20%	30%

**Table 7. Example Landed Duty Cycle for Full-Color**

Red Scale Value	Green Scale Value	Blue Scale Value	Landed Duty Cycle
0%	0%	0%	0/100
100%	0%	0%	50/50
0%	100%	0%	20/80
0%	0%	100%	30/70
12%	0%	0%	6/94
0%	35%	0%	7/93
0%	0%	60%	18/82
100%	100%	0%	70/30
0%	100%	100%	50/50
100%	0%	100%	80/20
12%	35%	0%	13/87
0%	35%	60%	25/75
12%	0%	60%	24/76
100%	100%	100%	100/0

## 8 Application and Implementation

### NOTE

Information in the following applications sections is not part of the TI component specification, and TI does not warrant its accuracy or completeness. TI's customers are responsible for determining suitability of components for their purposes. Customers should validate and test their design implementation to confirm system functionality.

### 8.1 Application Information

Texas Instruments DLP technology is a micro-electro-mechanical systems (MEMS) technology that modulates light using a digital micromirror device (DMD). DMDs vary in resolution and size and can contain over 8 million micromirrors. Each micromirror of a DMD can represent either one or more pixels on the display and is independently controlled, synchronized with color sequential illumination, to create stunning images on any surface. DLP technology enables a wide variety of display products worldwide, from tiny projection modules embedded in smartphones to high powered digital cinema projectors, and emerging display products such as digital signage and laser TV.

The most recent class of chipsets from Texas Instruments is based on a breakthrough micromirror technology, called TRP. With a smaller pixel pitch of 5.4  $\mu\text{m}$  and increased tilt angle of 17 degrees, TRP chipsets enable higher resolution in a smaller form factor and enhanced image processing features while maintaining high optical efficiency. DLP chipsets are a great fit for any system that requires high resolution and high brightness displays.

### 8.2 Typical Application

The DLP660TE DMD is the first full 4K UHD DLP digital micromirror device. When combined with two display controllers (DLPC4422), an FPGA, a power management device (DLPA100), and other electrical, optical and mechanical components the chipset enables bright, affordable, full 4K UHD display solutions. A typical 4K UHD system application using the DLP660TE DMD is shown in Figure 12.

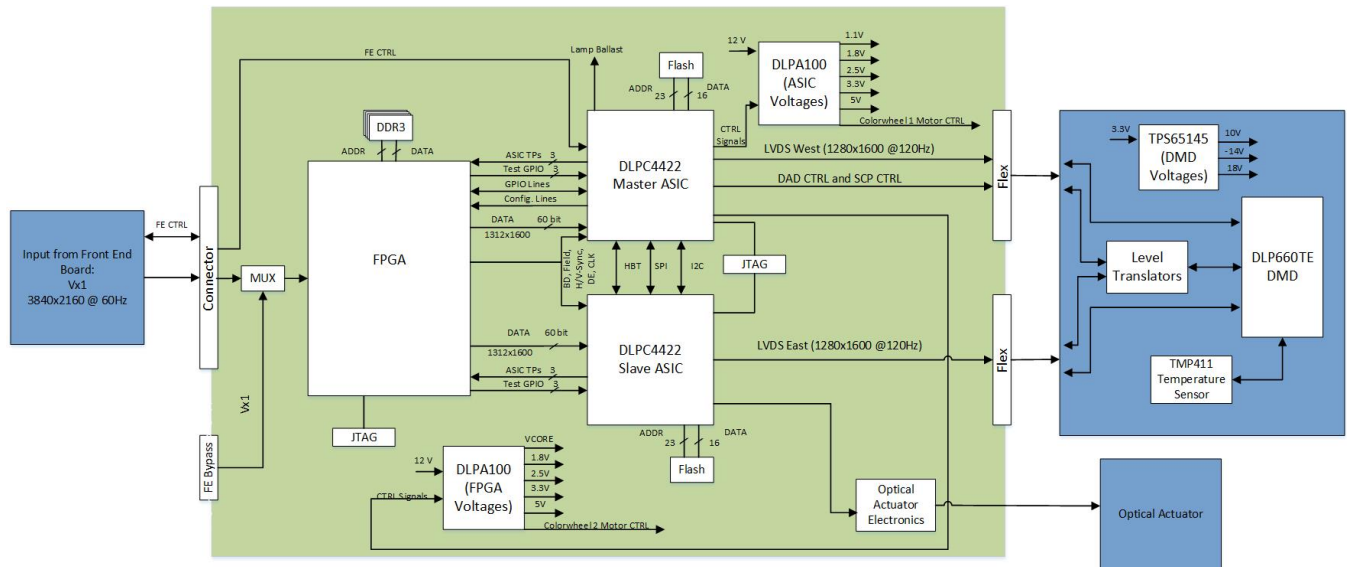

Figure 12. Typical 4K UHD Application Diagram

## Typical Application (continued)

### 8.2.1 Design Requirements

At the high level, DLP660TE DMD systems will include an illumination source, a light engine, electronic components, and software. The designer must first choose an illumination source and design the optical engine taking into consideration the relationship between the optics and the illumination source. The designer must then understand the electronic components of a DLP660TE DMD system, which is made up of a DMD board and formatter board. The DMD board channels image data to and powers the DMD chip. The formatter board supports the rest of the electronic components, which can include an FPGA, the DLPC4422 display controller, power supplies, and drivers for illumination sources, color wheels, fans, and dynamic optical components.

### 8.2.2 Detailed Design Procedure

For connecting together the DLPC4422 display controller and the DLP660TE DMD, see the reference design schematic. Layout guidelines should be followed to achieve a reliable projector. To complete the DLP system an optical module or light engine is required that contains the DLP660TE DMD, associated illumination sources, optical elements, and necessary mechanical components.

### 8.2.3 Application Curves

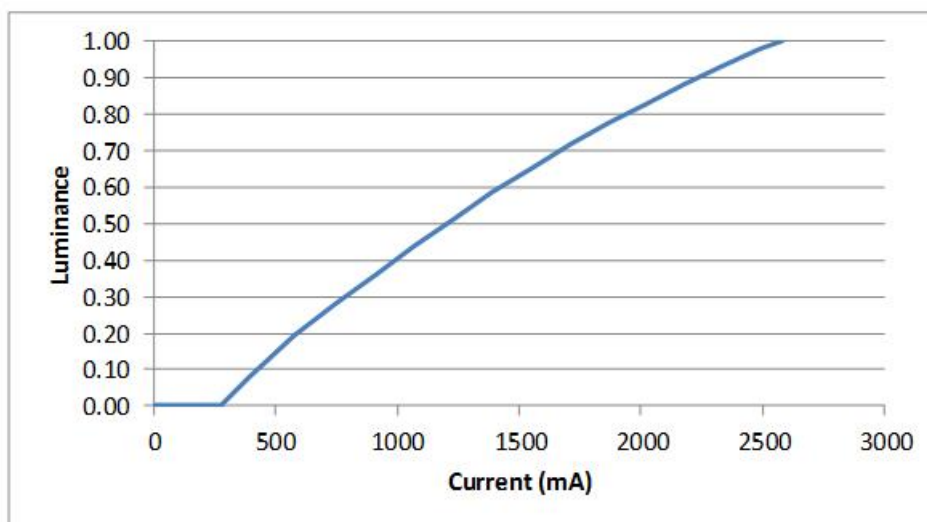

**Figure 13. Luminance vs. Current**

## 8.3 DMD Die Temperature Sensing

The DMD features a built-in thermal diode that measures the temperature at one corner of the die outside the micromirror array. The thermal diode can be interfaced with the TMP411 temperature sensor as shown in [Figure 14](#). The serial bus from the TMP411 can be connected to the DLPC4422 display controller to enable its temperature sensing features. See the DLPC4422 Programmers' Guide for instructions on installing the DLPC4422 controller support firmware bundle and obtaining the temperature readings.

The software application contains functions to configure the TMP411 to read the DMD temperature sensor diode. This data can be leveraged to incorporate additional functionality in the overall system design such as adjusting illumination, fan speeds, and so forth. All communication between the TMP411 and the DLPC4422 controller will be completed using the I<sup>2</sup>C interface. The TMP411 connects to the DMD via pins E16 and E17 as outlined in [Pin Configuration and Functions](#).

## DMD Die Temperature Sensing (continued)

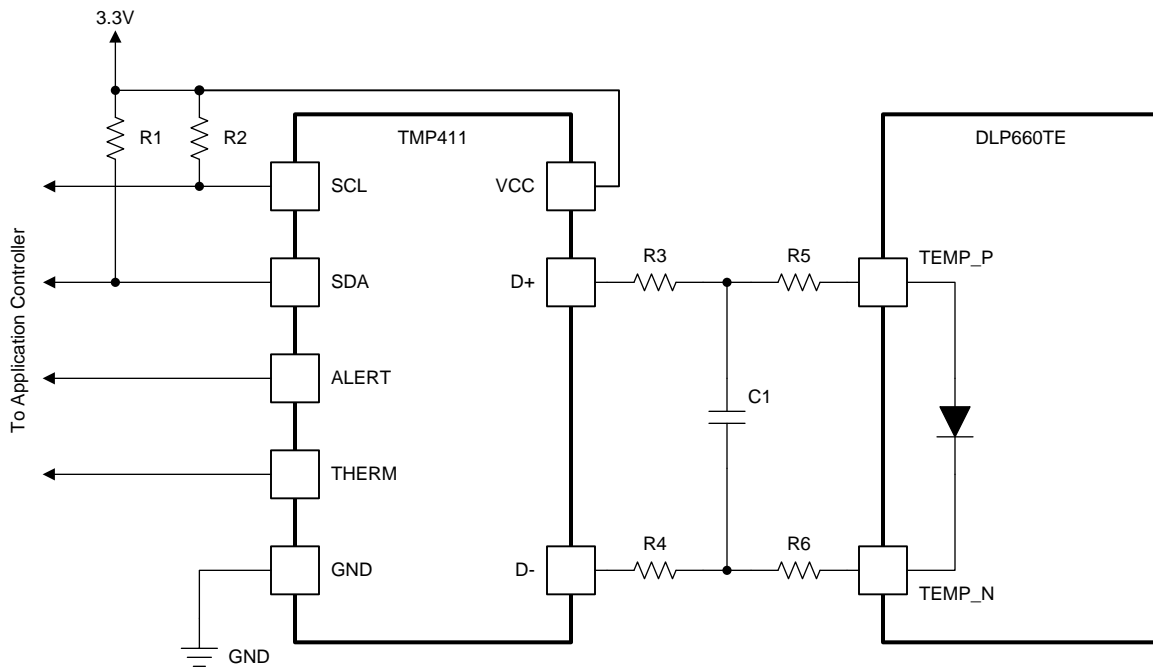

- (1) Details omitted for clarity, see the [TI Reference Design](#) for connections to the DLPC4422 controller.
- (2) See the [TMP411](#) datasheet for system board layout recommendation.
- (3) See the [TMP411](#) datasheet and the TI reference design for suggested component values for R1, R2, R3, R4, and C1.
- (4) R5 = 0 Ω. R6 = 0 Ω. Zero ohm resistors should be located close to the DMD package pins.

**Figure 14. TMP411 Sample Schematic**

## 9 Power Supply Recommendations

The following power supplies are all required to operate the DMD:

- VSS
- VCC
- VCCI
- VBIAS
- VOFFSET
- VRESET

DMD power-up and power-down sequencing is strictly controlled by the DLP display controller.

### CAUTION

For reliable operation of the DMD, the following power supply sequencing requirements must be followed. Failure to adhere to any of the prescribed power-up and power-down requirements may affect device reliability. See [Figure 15 DMD Power Supply Sequencing Requirements](#).

VBIAS, VCC, VCCI, VOFFSET, and VRESET power supplies must be coordinated during power-up and power-down operations. Failure to meet any of the below requirements will result in a significant reduction in the DMD's reliability and lifetime. Common ground VSS must also be connected.

### 9.1 DMD Power Supply Power-Up Procedure

- During power-up, VCC and VCCI must always start and settle before VOFFSET plus Delay1 specified in [Table 8](#), VBIAS, and VRESET voltages are applied to the DMD.
- During power-up, it is a strict requirement that the voltage delta between VBIAS and VOFFSET must be within the specified limit shown in [Recommended Operating Conditions](#).
- During power-up, there is no requirement for the relative timing of VRESET with respect to VBIAS.
- Power supply slew rates during power-up are flexible, provided that the transient voltage levels follow the requirements specified in [Absolute Maximum Ratings](#), in [Recommended Operating Conditions](#), and in [Figure 15](#).
- During power-up, LVCMOS input pins must not be driven high until after VCC and VCCI have settled at operating voltages listed in [Recommended Operating Conditions](#).

### 9.2 DMD Power Supply Power-Down Procedure

- During power-down, VCC and VCCI must be supplied until after VBIAS, VRESET, and VOFFSET are discharged to within the specified limit of ground. See [Table 8](#).
- During power-down, it is a strict requirement that the voltage delta between VBIAS and VOFFSET must be within the specified limit shown in [Recommended Operating Conditions](#).
- During power-down, there is no requirement for the relative timing of VRESET with respect to VBIAS.
- Power supply slew rates during power-down are flexible, provided that the transient voltage levels follow the requirements specified in [Absolute Maximum Ratings](#), in [Recommended Operating Conditions](#), and in [Figure 15](#).
- During power-down, LVCMOS input pins must be less than specified in [Recommended Operating Conditions](#).



DMD Power Supply Power-Down Procedure (continued)

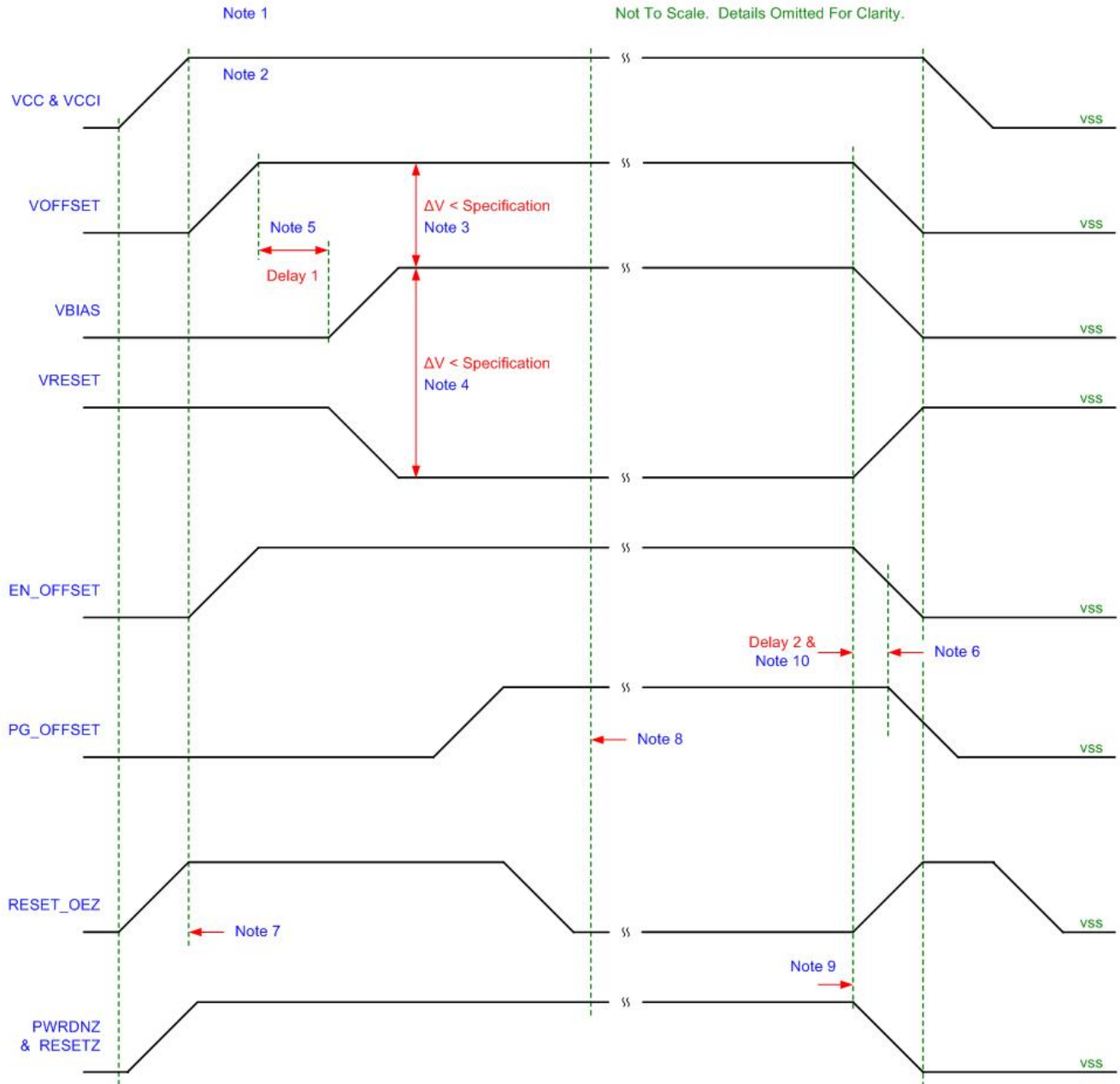

Figure 15. DMD Power Supply Requirements

1. See *Recommended Operating Conditions*, Pin Functions.
2. To prevent excess current, the supply voltage delta  $|VCCI - VCC|$  must be less than specified limit in *Recommended Operating Conditions*.
3. To prevent excess current, the supply voltage delta  $|VBIAS - VOFFSET|$  must be less than specified in *Recommended Operating Conditions*.
4. To prevent excess current, the supply voltage delta  $|VBIAS - VRESET|$  must be less than specified limit in *Recommended Operating Conditions*.
5. VBIAS should power up after VOFFSET has powered up, per the Delay1 specification in [Table 8](#).
6. PG\_OFFSET should turn off after EN\_OFFSET has turned off, per the Delay2 specification in [Table 8](#).

**DMD Power Supply Power-Down Procedure (continued)**

7. DLP controller software enables the DMD power supplies to turn on after RESET\_OEZ is at logic high.
8. DLP controller software initiates the global VBIAS command.
9. After the DMD micromirror park sequence is complete, the DLP controller software initiates a hardware power-down that activates PWRDNZ and disables VBIAS, VRESET and VOFFSET.
10. Under power-loss conditions where emergency DMD micromirror park procedures are being enacted by the DLP controller hardware, EN\_OFFSET may turn off after PG\_OFFSET has turned off. The OEZ signal should go high prior to PG\_OFFSET turning off to indicate the DMD micromirror has completed the emergency park procedures.

**Table 8. DMD Power-Supply Requirements**

Parameter	Description	Min	NOM	Max	Unit
Delay1	Delay from VOFFSET settled at recommended operating voltage to VBIAS and VRESET power up	1	2		ms
Delay2	PG_OFFSET hold time after EN_OFFSET goes low	100			ns

## 10 Layout

### 10.1 Layout Guidelines

The DLP660TE DMD is part of a chipset that is controlled by the DLPC4422 display controller in conjunction with the DLPA100 power and motor driver. These guidelines are targeted at designing a PCB board with the DLP660TE DMD. The DLP660TE DMD board is a high-speed multi-layer PCB, with primarily high-speed digital logic utilizing dual edge clock rates up to 400MHz for DMD LVDS signals. The remaining traces are comprised of low speed digital LVTTTL signals. TI recommends that mini power planes are used for VOFFSET, VRESET, and VBIAS. Solid planes are required for DMD\_P3P3V(3.3V), DMD\_P1P8V and Ground. The target impedance for the PCB is  $50\ \Omega \pm 10\%$  with the LVDS traces being  $100\ \Omega \pm 10\%$  differential. TI recommends using an 8 layer stack-up as described in [Table 9](#).

### 10.2 Layout Example

#### 10.2.1 Layers

The layer stack-up and copper weight for each layer is shown in [Table 9](#). Small sub-planes are allowed on signal routing layers to connect components to major sub-planes on top/bottom layers if necessary.

**Table 9. Layer Stack-Up**

LAYER NO.	LAYER NAME	COPPER WT. (oz.)	COMMENTS
1	Side A - DMD only	1.5	DMD, escapes, low frequency signals, power sub-planes.
2	Ground	1	Solid ground plane (net GND).
3	Signal	0.5	$50\ \Omega$ and $100\ \Omega$ differential signals
4	Ground	1	Solid ground plane (net GND)
5	DMD_P3P3V	1	+3.3-V power plane (net DMD_P3P3V)
6	Signal	0.5	$50\ \Omega$ and $100\ \Omega$ differential signals
7	Ground	1	Solid ground plane (net GND).
8	Side B - All other Components	1.5	Discrete components, low frequency signals, power sub-planes

#### 10.2.2 Impedance Requirements

TI recommends that the board has matched impedance of  $50\ \Omega \pm 10\%$  for all signals. The exceptions are listed in [Table 10](#).

**Table 10. Special Impedance Requirements**

Signal Type	Signal Name	Impedance (ohms)
A channel LVDS differential pairs	D_AP(0:15), D_AN(0:15)	$100\ \pm 10\%$ differential across each pair
	DCLKA_P, DCLKA_N	
	SCTRL_AP, SCTRL_AN	
B channel LVDS differential pairs	D_BP(0:15), D_BN(0:15)	$100\ \pm 10\%$ differential across each pair
	DCLKB_P, DCLKB_N	
	SCTRL_BP, SCTRL_BN	
C channel LVDS differential pairs	D_CP(0:15), D_CN(0:15)	$100\ \pm 10\%$ differential across each pair
	DCLKC_P, DCLKC_N	
	SCTRL_CP, SCTRL_CN	
D channel LVDS differential pairs	D_DP(0:15), D_DN(0:15)	$100\ \pm 10\%$ differential across each pair
	DCLKD_P, DCLKD_N	
	SCTRL_DP, SCTRL_DN	

### 10.2.3 Trace Width, Spacing

Unless otherwise specified, TI recommends that all signals follow the 0.005"/0.005" design rule. Minimum trace clearance from the ground ring around the PWB has a 0.1" minimum. An analysis of impedance and stack-up requirements determine the actual trace widths and clearances.

#### 10.2.3.1 Voltage Signals

**Table 11. Special Trace Widths, Spacing Requirements**

SIGNAL NAME	MINIMUM TRACE WIDTH TO PINS (MIL)	LAYOUT REQUIREMENT
GND	15	Maximize trace width to connecting pin
DMD_P3P3V	15	Maximize trace width to connecting pin
DMD_P1P8V	15	Maximize trace width to connecting pin
VOFFSET	15	Create mini plane from U2 to U3
VRESET	15	Create mini plane from U2 to U3
VBIAS	15	Create mini plane from U2 to U3
All U3 control connections	10	Use 10 mil etch to connect all signals/voltages to DMD pads

## 11 Device and Documentation Support

### 11.1 Device Support

#### 11.1.1 Device Nomenclature

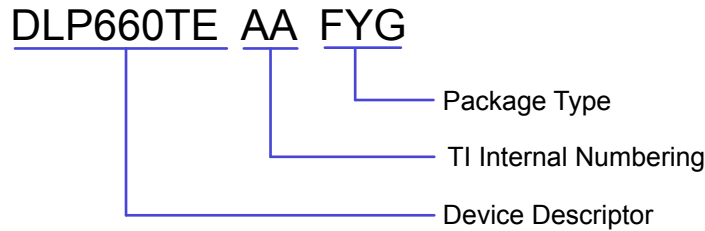

Figure 16. Part Number Description

#### 11.1.2 Device Markings

The device marking will include both human-readable information and a 2-dimensional matrix code. The human-readable information is described in Figure 17. The 2-dimensional matrix code is an alpha-numeric character string that contains the DMD part number, Part 1 of Serial Number, and Part 2 of Serial Number. The first character of the DMD Serial Number (part 1) is the manufacturing year. The second character of the DMD Serial Number (part 1) is the manufacturing month. The last character of the DMD Serial Number (part 2) is the bias voltage bin letter.

Example: \*2715-7032 GHXXXXX LLLLLLM

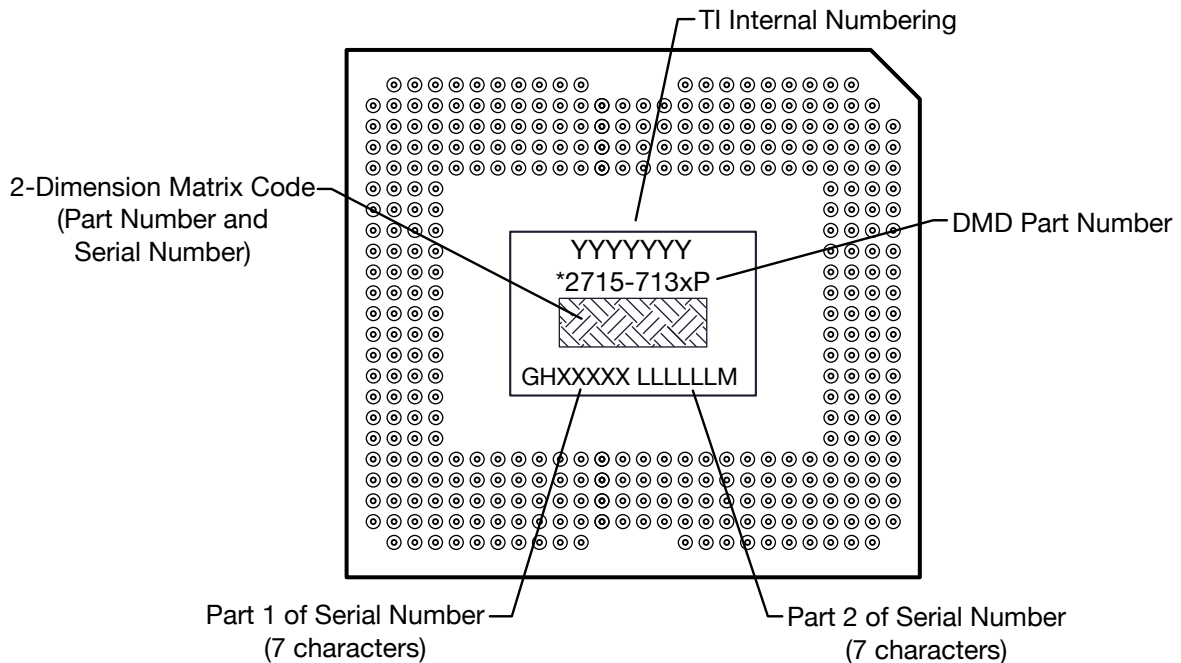

Figure 17. DMD Marking Locations

## 11.2 Documentation Support

### 11.2.1 Related Documentation

The following documents contain additional information related to the chipset components used with the DLP660TE:

- DLPC4422 Display Controller
- DLPA100 Power and Motor Driver Data Sheet

### 11.3 Receiving Notification of Documentation Updates

To receive notification of documentation updates, navigate to the device product folder on ti.com. In the upper right corner, click on *Alert me* to register and receive a weekly digest of any product information that has changed. For change details, review the revision history included in any revised document.

### 11.4 Community Resources

The following links connect to TI community resources. Linked contents are provided "AS IS" by the respective contributors. They do not constitute TI specifications and do not necessarily reflect TI's views; see TI's [Terms of Use](#).

**TI E2E™ Online Community** *TI's Engineer-to-Engineer (E2E) Community*. Created to foster collaboration among engineers. At e2e.ti.com, you can ask questions, share knowledge, explore ideas and help solve problems with fellow engineers.

**Design Support** *TI's Design Support* Quickly find helpful E2E forums along with design support tools and contact information for technical support.

### 11.5 Trademarks

E2E is a trademark of Texas Instruments.

DLP is a registered trademark of Texas Instruments.

### 11.6 Electrostatic Discharge Caution



These devices have limited built-in ESD protection. The leads should be shorted together or the device placed in conductive foam during storage or handling to prevent electrostatic damage to the MOS gates.

### 11.7 Glossary

**SLYZ022** — *TI Glossary*.

This glossary lists and explains terms, acronyms, and definitions.

## 12 Mechanical, Packaging, and Orderable Information

The following pages include mechanical, packaging, and orderable information. This information is the most current data available for the designated devices. This data is subject to change without notice and revision of this document. For browser-based versions of this data sheet, refer to the left-hand navigation.

**PACKAGING INFORMATION**

Orderable Device	Status (1)	Package Type	Package Drawing	Pins	Package Qty	Eco Plan (2)	Lead/Ball Finish (6)	MSL Peak Temp (3)	Op Temp (°C)	Device Marking (4/5)	Samples
DLP660TEAAFYG	ACTIVE	CPGA	FYG	350	1	RoHS & non-Green	Call TI	Call TI			Samples
DLP660TEFYG	OBSOLETE	CPGA	FYG	350		TBD	Call TI	Call TI			

(1) The marketing status values are defined as follows:

**ACTIVE:** Product device recommended for new designs.

**LIFEBUY:** TI has announced that the device will be discontinued, and a lifetime-buy period is in effect.

**NRND:** Not recommended for new designs. Device is in production to support existing customers, but TI does not recommend using this part in a new design.

**PREVIEW:** Device has been announced but is not in production. Samples may or may not be available.

**OBSOLETE:** TI has discontinued the production of the device.

(2) **RoHS:** TI defines "RoHS" to mean semiconductor products that are compliant with the current EU RoHS requirements for all 10 RoHS substances, including the requirement that RoHS substance do not exceed 0.1% by weight in homogeneous materials. Where designed to be soldered at high temperatures, "RoHS" products are suitable for use in specified lead-free processes. TI may reference these types of products as "Pb-Free".

**RoHS Exempt:** TI defines "RoHS Exempt" to mean products that contain lead but are compliant with EU RoHS pursuant to a specific EU RoHS exemption.

**Green:** TI defines "Green" to mean the content of Chlorine (Cl) and Bromine (Br) based flame retardants meet JS709B low halogen requirements of <=1000ppm threshold. Antimony trioxide based flame retardants must also meet the <=1000ppm threshold requirement.

(3) MSL, Peak Temp. - The Moisture Sensitivity Level rating according to the JEDEC industry standard classifications, and peak solder temperature.

(4) There may be additional marking, which relates to the logo, the lot trace code information, or the environmental category on the device.

(5) Multiple Device Markings will be inside parentheses. Only one Device Marking contained in parentheses and separated by a "~" will appear on a device. If a line is indented then it is a continuation of the previous line and the two combined represent the entire Device Marking for that device.

(6) Lead/Ball Finish - Orderable Devices may have multiple material finish options. Finish options are separated by a vertical ruled line. Lead/Ball Finish values may wrap to two lines if the finish value exceeds the maximum column width.

**Important Information and Disclaimer:**The information provided on this page represents TI's knowledge and belief as of the date that it is provided. TI bases its knowledge and belief on information provided by third parties, and makes no representation or warranty as to the accuracy of such information. Efforts are underway to better integrate information from third parties. TI has taken and continues to take reasonable steps to provide representative and accurate information but may not have conducted destructive testing or chemical analysis on incoming materials and chemicals. TI and TI suppliers consider certain information to be proprietary, and thus CAS numbers and other limited information may not be available for release.

In no event shall TI's liability arising out of such information exceed the total purchase price of the TI part(s) at issue in this document sold by TI to Customer on an annual basis.



REVISIONS			
REV	DESCRIPTION	DATE	APPROVED
A	ECO 2146754, INITIAL RELEASE	11/18/2014	M. AVERY
B	ECO 2147303, ADD GLASS DIMS	12/18/2014	F. ARMSTRONG
C	ECO 2149265, CHG ARRAY TO 1528 ROWS	03/17/2015	F. ARMSTRONG
D	ECO 2156970, CHG NUMERICAL IDENTIFIER TO 317	03/17/2016	F. ARMSTRONG

NOTES: UNLESS OTHERWISE SPECIFIED:

- 1 DIE PARALLELISM TOLERANCE APPLIES TO DMD ACTIVE ARRAY ONLY
- 2 ROTATION ANGLE OF DMD ACTIVE ARRAY IS A REFINEMENT OF THE LOCATION TOLERANCE AND HAS A MAXIMUM ALLOWED VALUE OF 0.8 DEGREES
- 3 SUBSTRATE SYMBOLIZATION PAD AND PLATING AT BOTTOM OF DATUMS B AND C HOLES ARE ELECTRICALLY CONNECTED TO VSS PLANE WITHIN THE SUBSTRATE
- 4 BOUNDARY MIRRORS SURROUNDING THE DMD ACTIVE AREA
- 5 MAXIMUM ENCAPSULANT PROFILE SHOWN
- 6 ENCAPSULANT ALLOWED ON THE SURFACE OF THE CERAMIC IN THE AREA SHOWN IN VIEW B (SHEET 2). ENCAPSULANT SHALL NOT EXCEED 0.200 THICKNESS MAXIMUM.
- 7 SUBSTRATES PLATED WITH Ni/Au SHALL HAVE THE THREE-DIGIT NUMERICAL MARKING IN THE AREA ABOVE THE SYMBOLIZATION PAD. SUBSTRATES PLATED WITH Ni/Pd/Au SHALL HAVE THE MARKING IN THE AREA BELOW THE SYMBOLIZATION PAD.

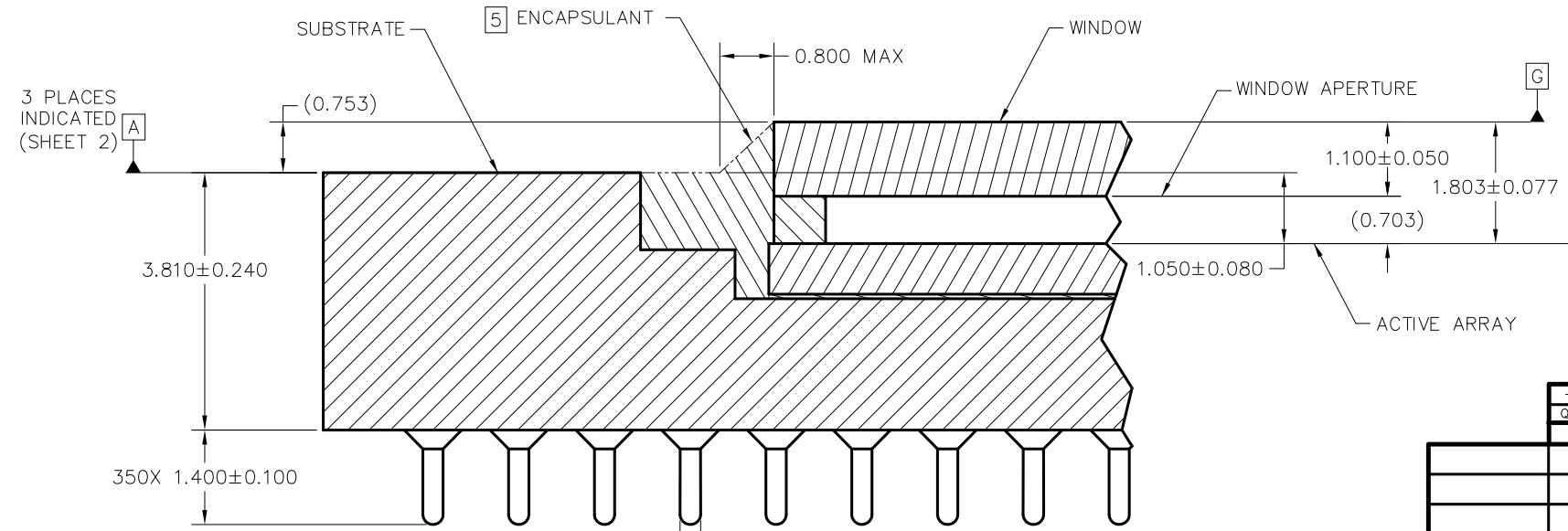
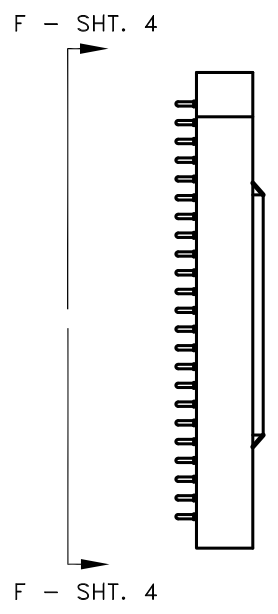
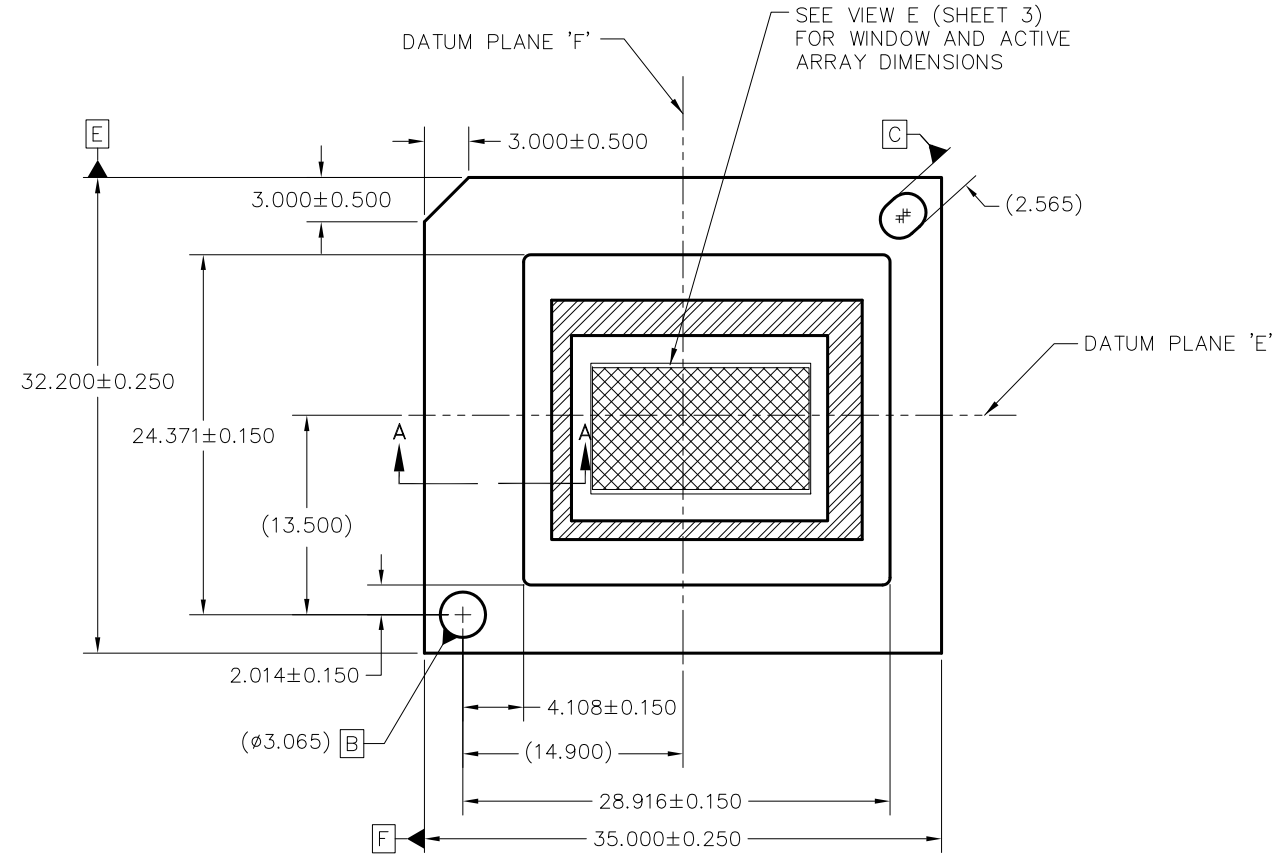
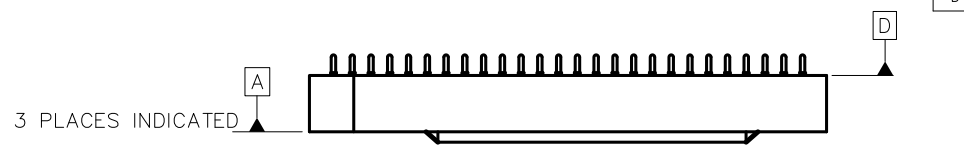

SECTION A-A  
SCALE 20/1

-1	ITEM	PART OR IDENTIFYING NUMBER	NOMENCLATURE OR DESCRIPTION	NOTES
QTY	NO			
PARTS LIST				
	ENGR	M. AVERY	DATE 11/18/2014	
	ENGR	F. ARMSTRONG	DATE 11/18/2014	
	QA	P. KONRAD	DATE 12/04/2014	
	QA	E. CARPENTER	DATE 12/04/2014	
	COE	M. DORAK	DATE 12/04/2014	
		S. SUSI	DATE 12/04/2014	

UNLESS OTHERWISE SPECIFIED DIMENSIONS ARE IN MILLIMETERS TOLERANCES: ANGLES ± 1° 2 PLACE DECIMALS ± 0.25 3 PLACE DECIMALS ± 0.50			
REMOVE ALL BURRS AND SHARP EDGES INTERPRET DIMENSIONS IN ACCORDANCE WITH ASME Y14.5-1994 DIMENSIONAL LIMITS APPLY BEFORE PROCESSES PARENTHEetical INFO FOR REF ONLY		ICD, MECHANICAL, DMD .66 UHD HB MTRP 2XLVDS SERIES 610 (FYG PACKAGE)	
THIRD ANGLE PROJECTION	NONE	0314DA	SIZE D
NEXT ASSY	USED ON	APPLICATION	DRAWING NO 2514366
			SCALE 4/1
			SHEET 1 OF 4

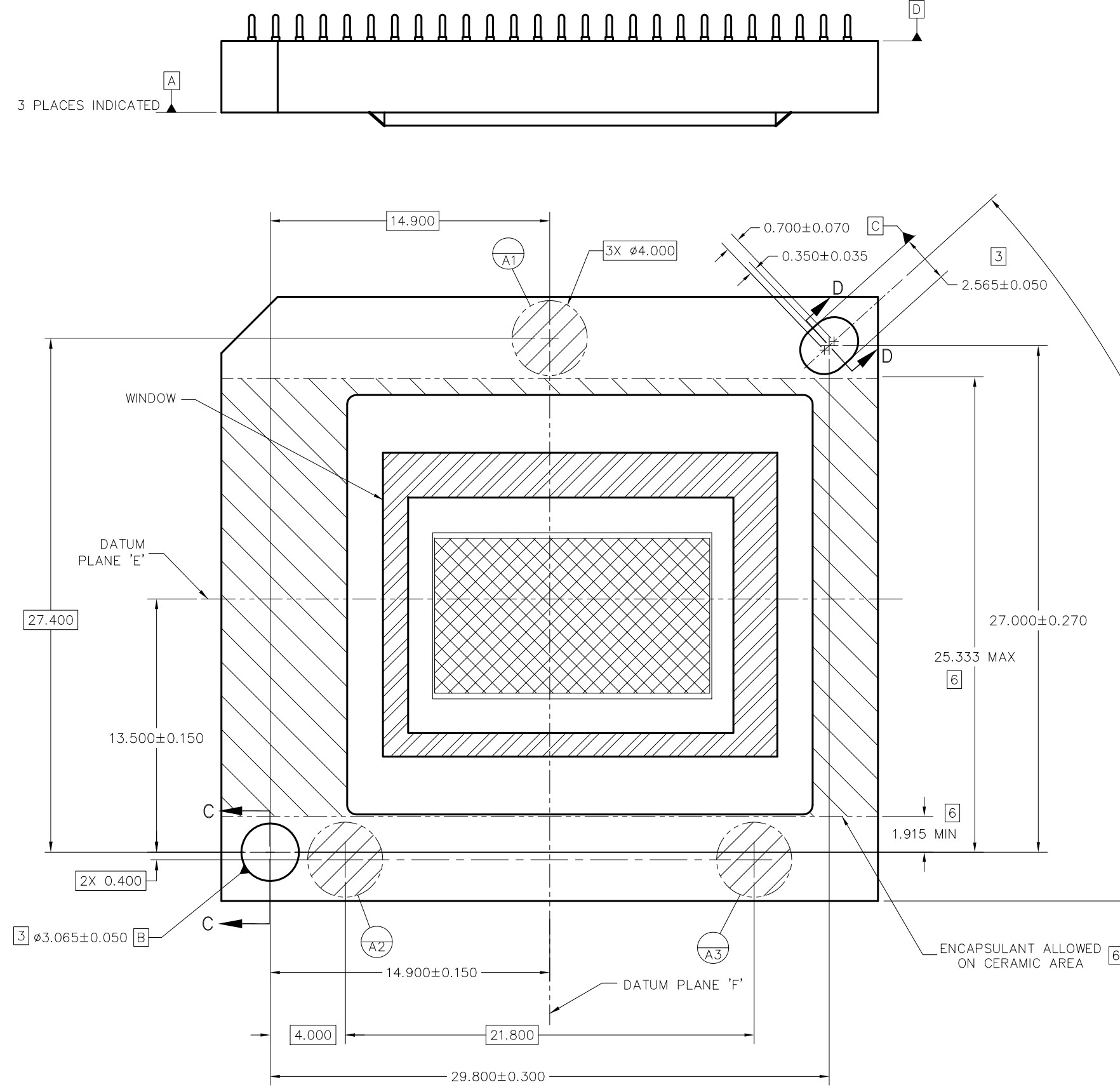

VIEW B  
DATUMS AND ENCAPSULANT ALLOWABLE AREA  
SCALE 8/1

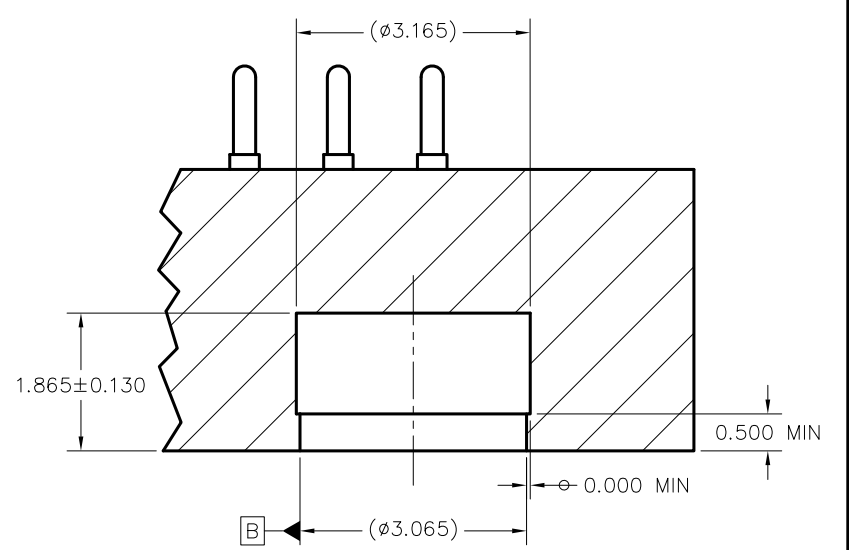

SECTION C-C  
DATUM B  
SCALE 16/1

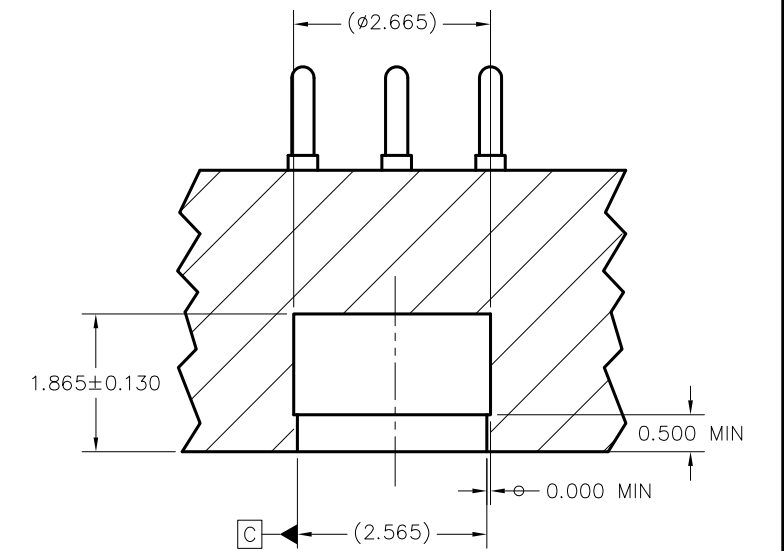

SECTION D-D  
DATUM C  
SCALE 16/1

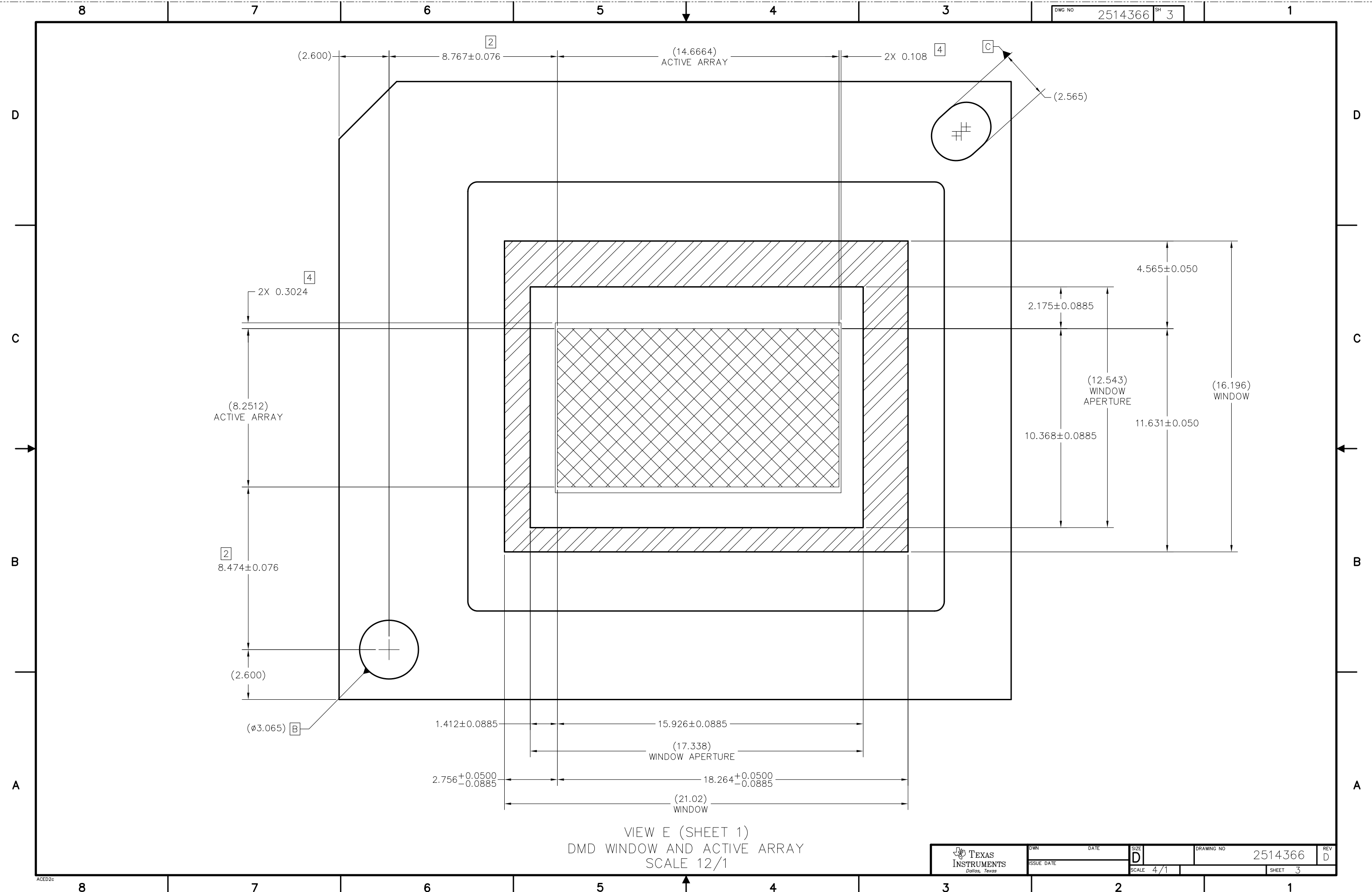

VIEW E (SHEET 1)  
DMD WINDOW AND ACTIVE ARRAY  
SCALE 12/1

D

C

B

A

D

C

B

A

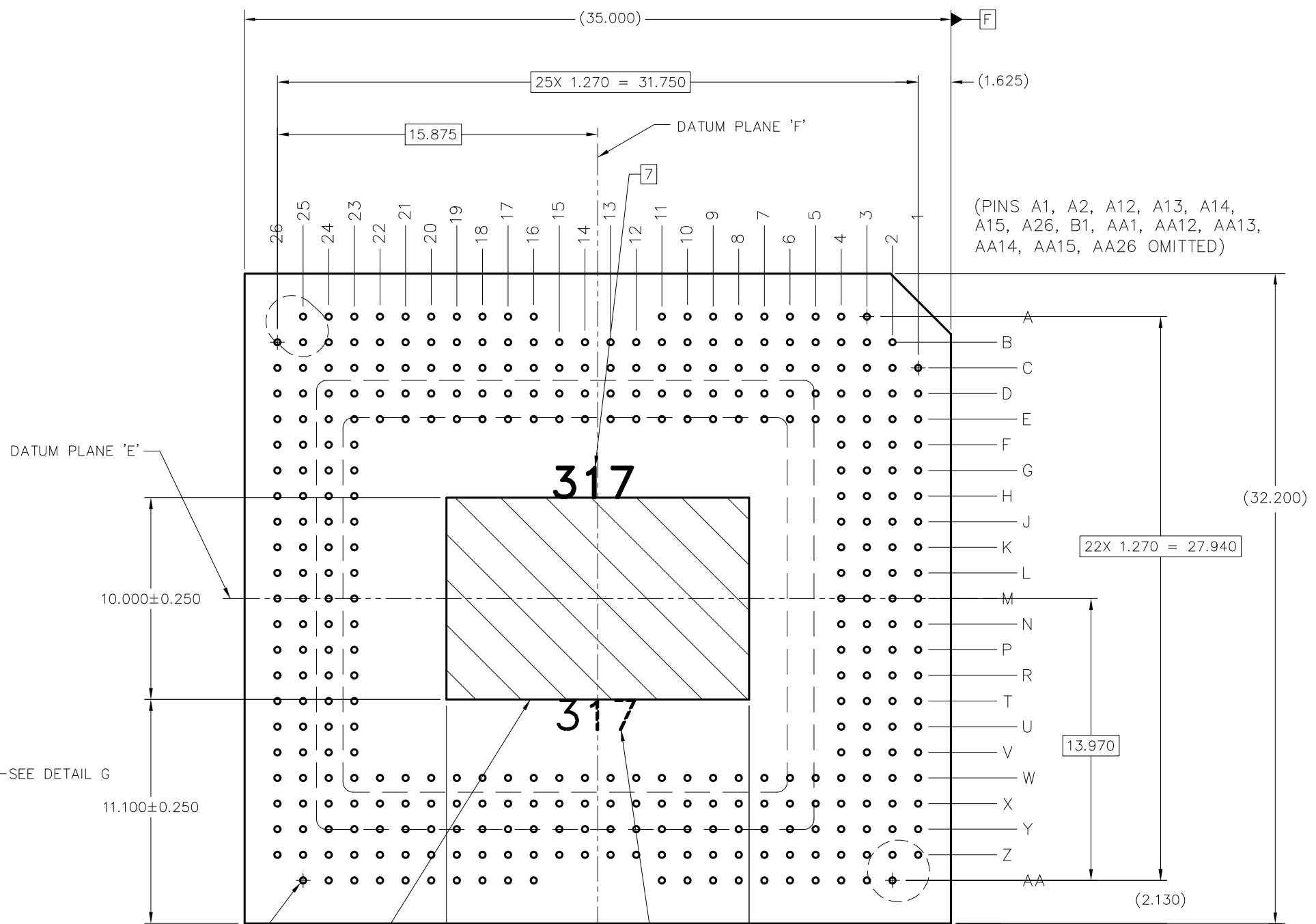
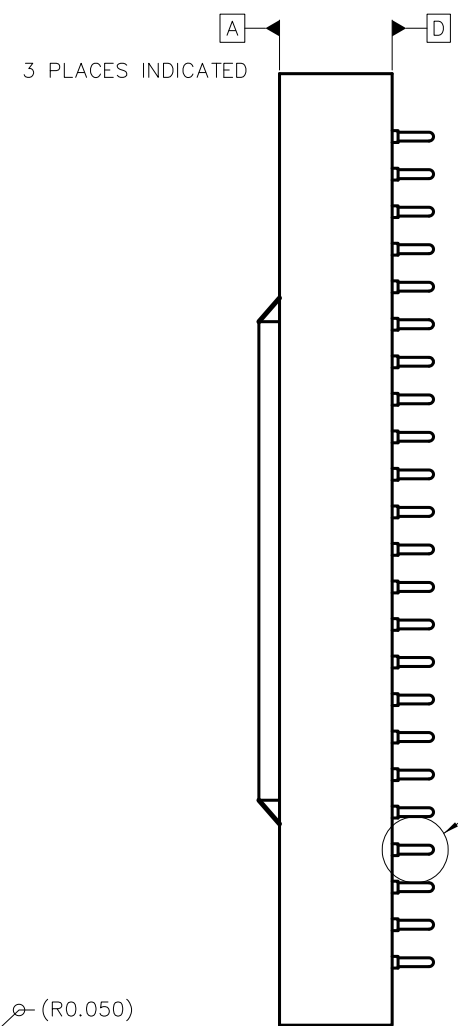

(PINS A1, A2, A12, A13, A14, A15, A26, B1, AA1, AA12, AA13, AA14, AA15, AA26 OMITTED)

350X  $\phi 0.305^{+0.050}_{-0.025}$  PINS

$\phi 0.500$	D	E	F
$\phi 0.250$	D		

3 SYMBOLIZATION PAD

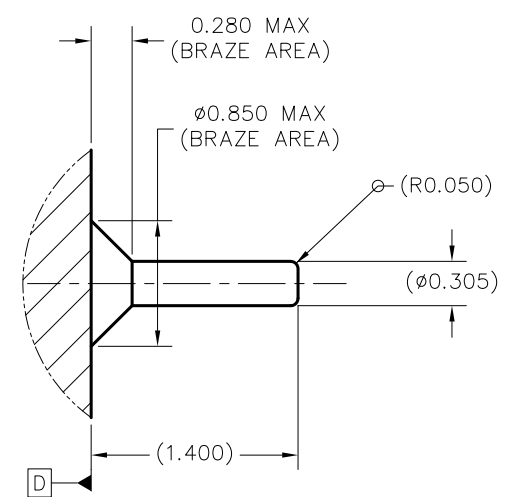

DETAIL G (350 PLACES)  
PIN & BRAZE DIMENSIONS  
SCALE 40/1

VIEW F-F (SHEET 1)  
PINS AND SYMBOLIZATION PAD  
SCALE 8/1

## IMPORTANT NOTICE AND DISCLAIMER

TI PROVIDES TECHNICAL AND RELIABILITY DATA (INCLUDING DATASHEETS), DESIGN RESOURCES (INCLUDING REFERENCE DESIGNS), APPLICATION OR OTHER DESIGN ADVICE, WEB TOOLS, SAFETY INFORMATION, AND OTHER RESOURCES "AS IS" AND WITH ALL FAULTS, AND DISCLAIMS ALL WARRANTIES, EXPRESS AND IMPLIED, INCLUDING WITHOUT LIMITATION ANY IMPLIED WARRANTIES OF MERCHANTABILITY, FITNESS FOR A PARTICULAR PURPOSE OR NON-INFRINGEMENT OF THIRD PARTY INTELLECTUAL PROPERTY RIGHTS.

These resources are intended for skilled developers designing with TI products. You are solely responsible for (1) selecting the appropriate TI products for your application, (2) designing, validating and testing your application, and (3) ensuring your application meets applicable standards, and any other safety, security, or other requirements. These resources are subject to change without notice. TI grants you permission to use these resources only for development of an application that uses the TI products described in the resource. Other reproduction and display of these resources is prohibited. No license is granted to any other TI intellectual property right or to any third party intellectual property right. TI disclaims responsibility for, and you will fully indemnify TI and its representatives against, any claims, damages, costs, losses, and liabilities arising out of your use of these resources.

TI's products are provided subject to TI's Terms of Sale ([www.ti.com/legal/termsofsale.html](http://www.ti.com/legal/termsofsale.html)) or other applicable terms available either on [ti.com](http://ti.com) or provided in conjunction with such TI products. TI's provision of these resources does not expand or otherwise alter TI's applicable warranties or warranty disclaimers for TI products.

Mailing Address: Texas Instruments, Post Office Box 655303, Dallas, Texas 75265  
Copyright © 2019, Texas Instruments Incorporated