

| REVISIONS | | | | |
|-----------|-----|---------------------------|-----------|----------|
| P | LTN | DESCRIPTION | DATE | DWN APVD |
| S3 | | REVISED PER ECR-17-008392 | 28JUN2017 | BW KR |

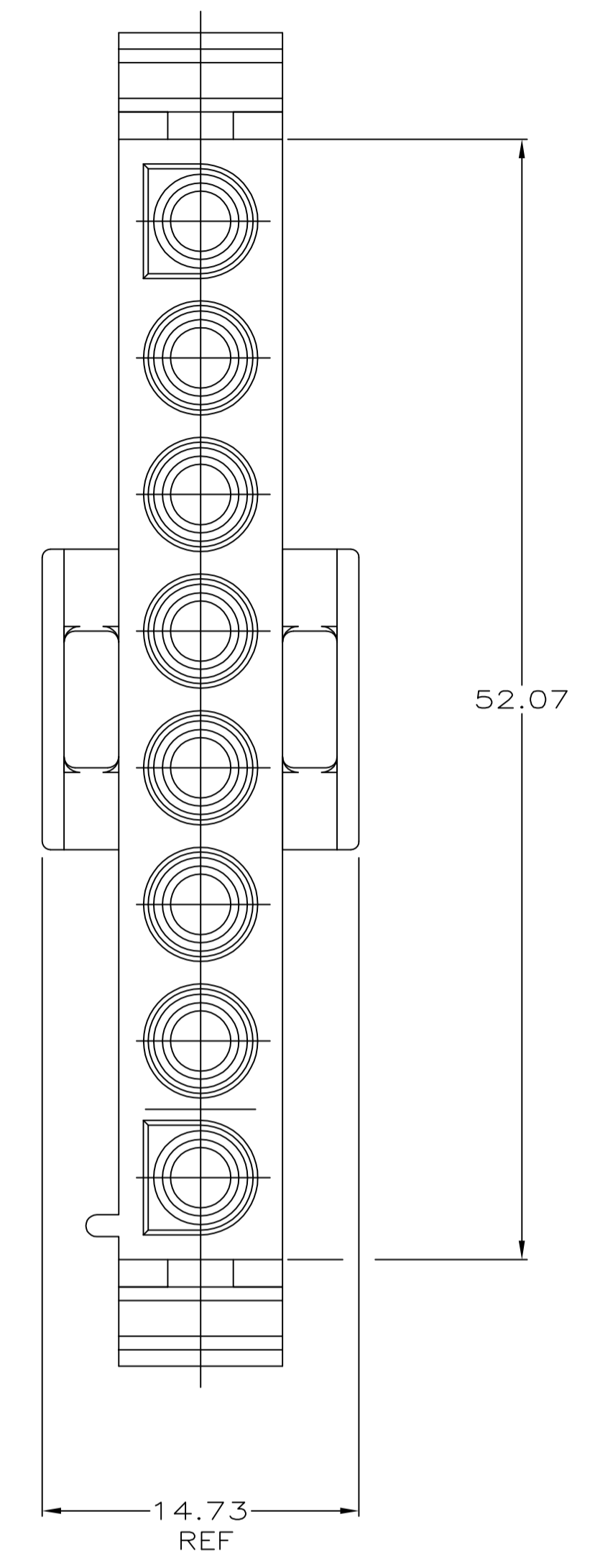

- MATES WITH APPROPRIATE UNIVERSAL MATE-N-LOK™ CAP OR HEADER.
 - SMALL NICKS ARE PERMITTED ON THE CIRCUIT TOWERS WHICH COULD INCREASE THE INITIAL HOUSING MATING FORCE BY UP TO 4.4 NEWTONS [1.0 LBS]. NO INDIVIDUAL NICKED TOWER SHALL INCREASE THIS FORCE BY OVER 2.2 NEWTONS [.5 LBS].
 - DIMENSIONS SHOWN REPRESENT PRODUCT IN DRY, AS MOLDED, CONDITION. ADDITIONAL 2% GROWTH DUE TO SUBSEQUENT MOISTURE ABSORPTION MAY OCCUR AND SHOULD BE ACCOUNTED FOR.
- △ FOUR RIBS EQUALLY SPACED, NO SPECIFIC ORIENTATION. NO RIBS OR SIX RIBS EQUALLY SPACED, NO SPECIFIC ORIENTATION, OPTIONAL.
 - △ UNDERWRITERS RECOGNIZED COMPONENT LOGO AND CSA CERTIFICATION LOGO TO BE LOCATED ONCE EACH ON SIDE OF HOUSING.
 - △ PRELIMINARY PART. NOT RELEASED FOR PRODUCTION.

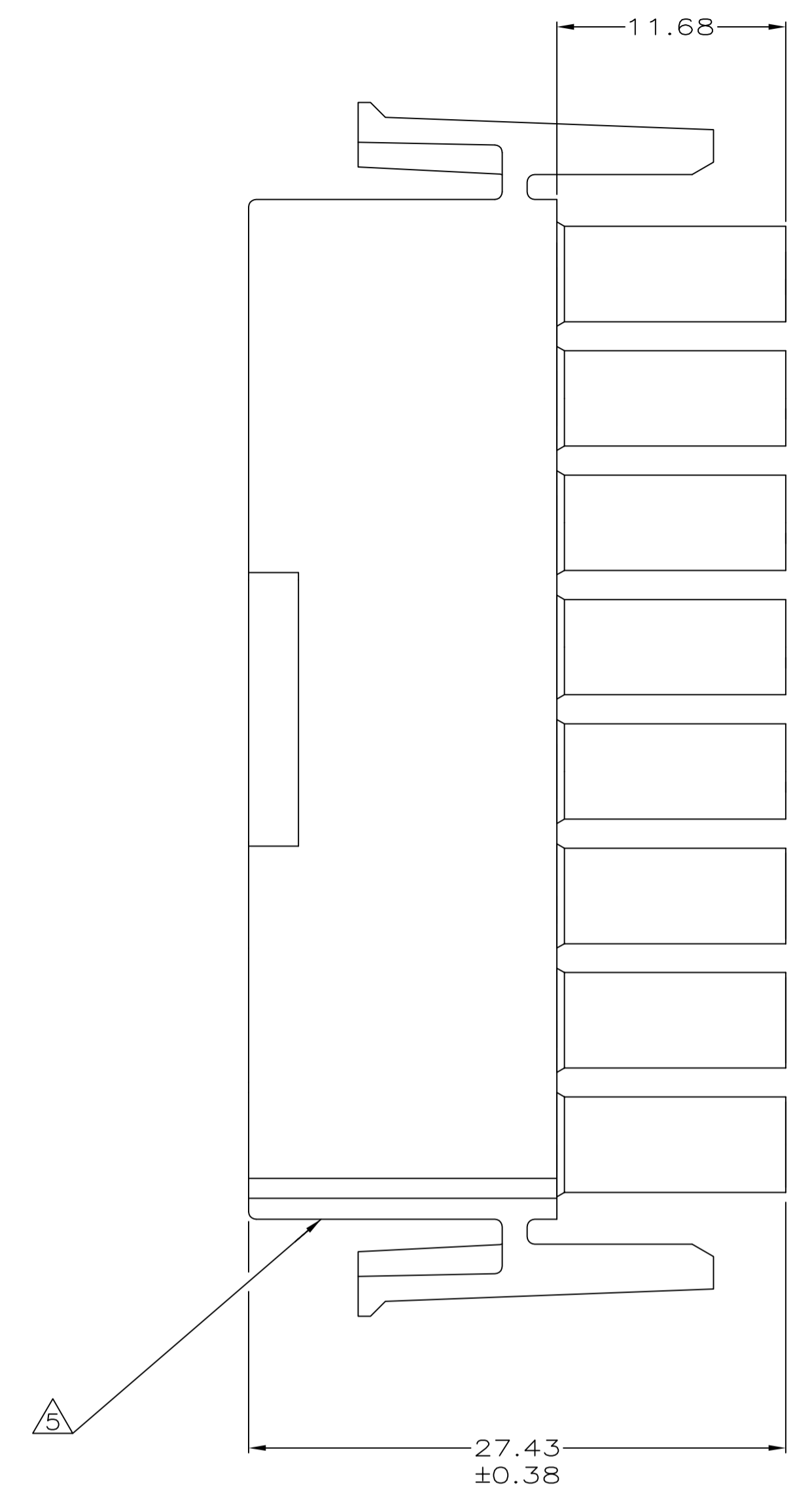
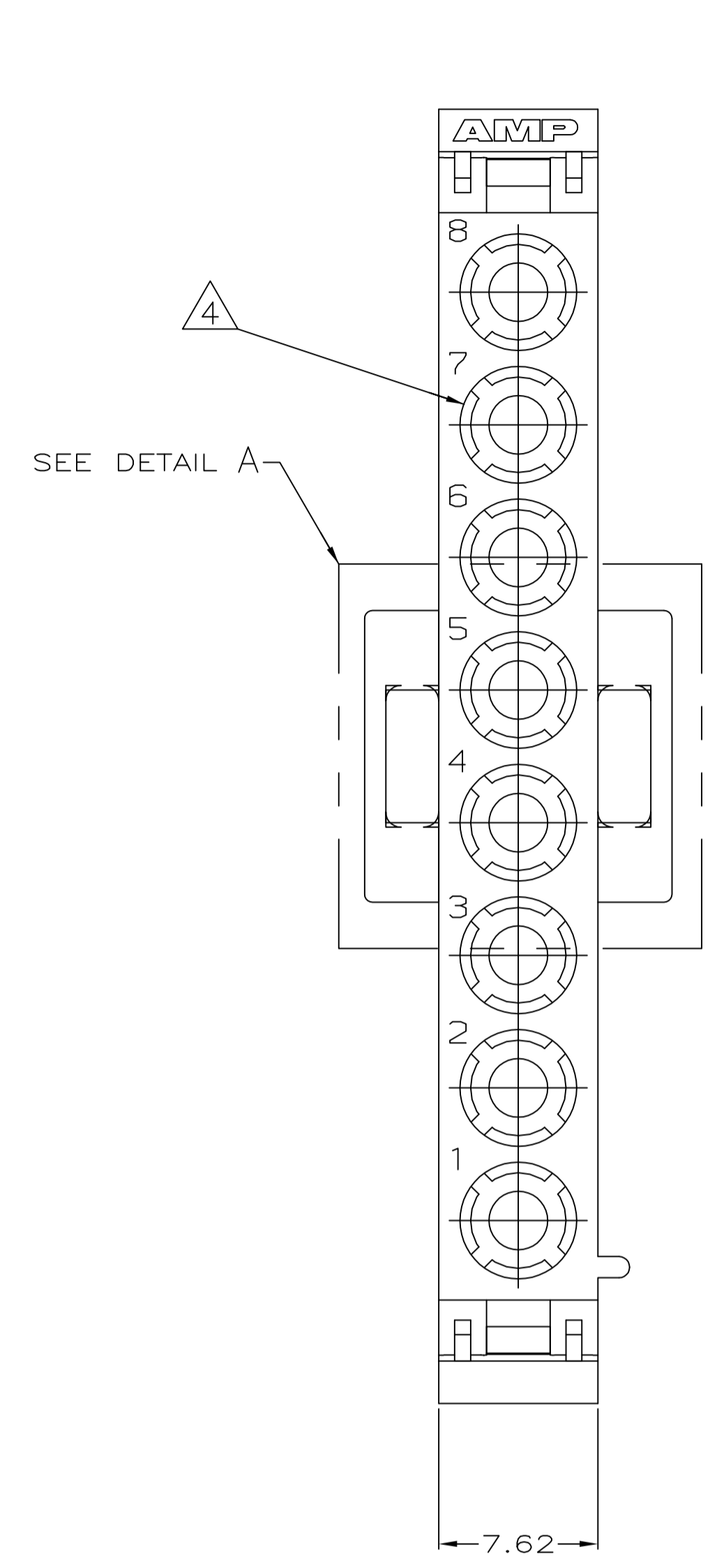
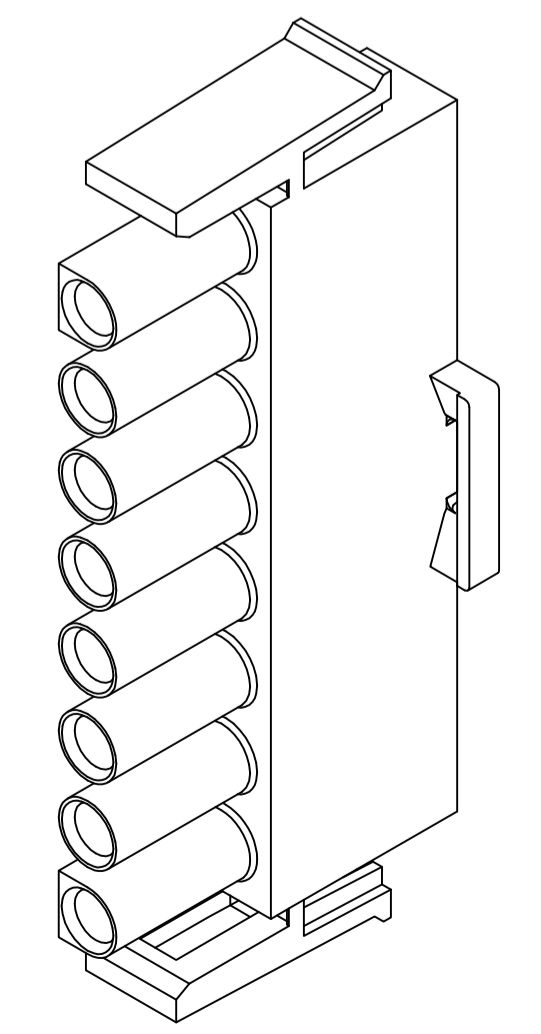

3-DIMENSIONAL MODEL NTS

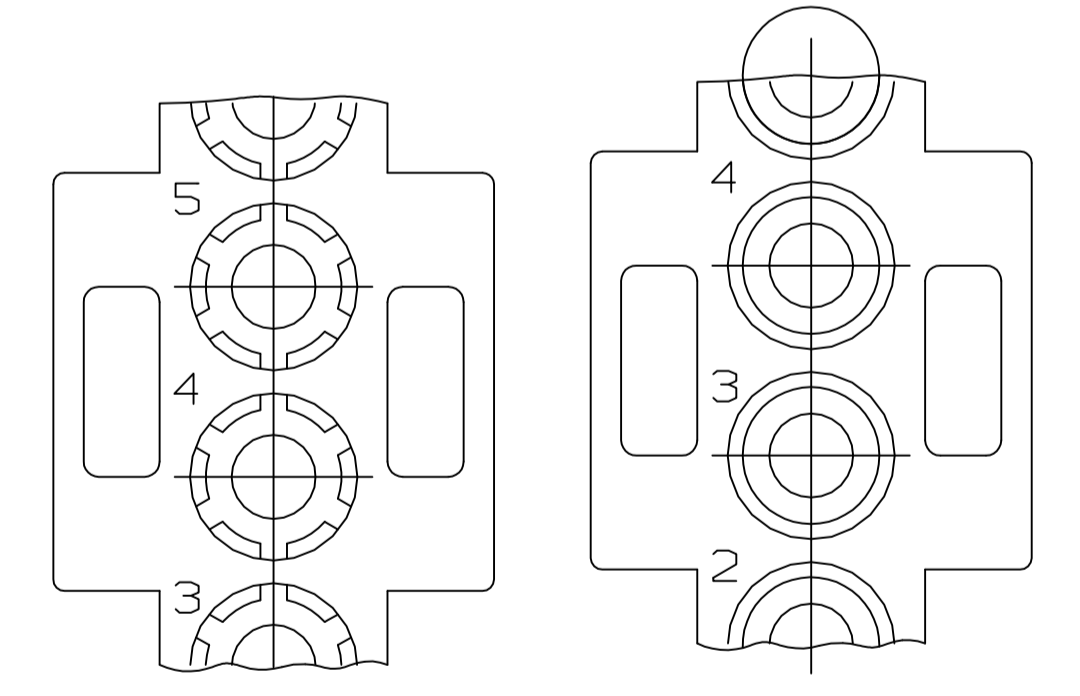
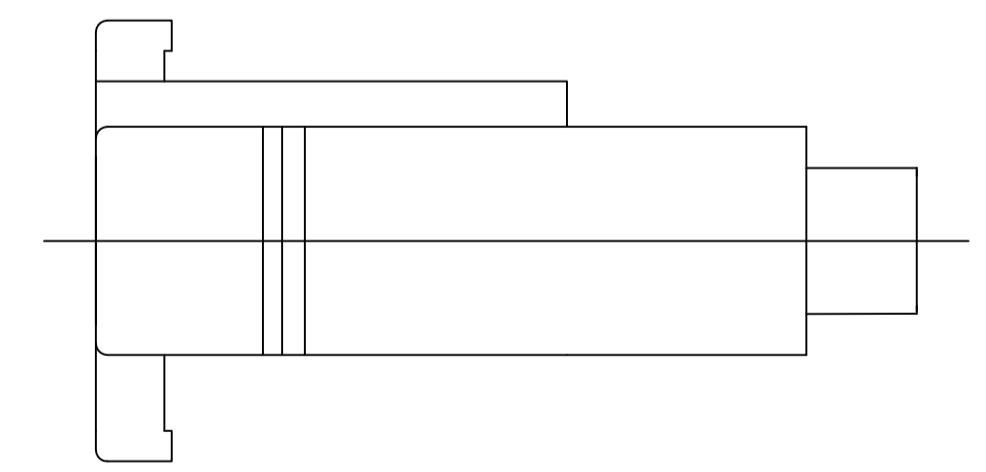

DETAIL A
 OPTIONAL CONSTRUCTIONS

| MM | IN |
|-------|-------|
| 52.07 | 2.050 |
| 27.43 | 1.080 |
| 14.73 | .580 |
| 11.68 | .460 |
| 7.62 | .300 |
| 0.38 | .015 |
| 0.13 | .005 |
| MM | IN |

CONVERSION TABLE

| | | | | | |
|--|--|-------------------------------|---------|--|------------|
| THIS DRAWING IS A CONTROLLED DOCUMENT. | | DWN K. WHITAKER 2-28-92 | 2-28-92 | RED | △ 640582-2 |
| DIMENSIONS: | | CHK P. SWING 2-28-92 | 3-5-92 | WHITE | 640582-1 |
| TOLERANCES UNLESS OTHERWISE SPECIFIED: | | APVD D. SELF 3-5-92 | NAME | COLOR | PART NO |
| 0 PLC ± - | | PRODUCT SPEC | | STE TE Connectivity | |
| 1 PLC ± - | | 108-1031 | | PLUG, 8 CIRCUIT, UNIVERSAL MATE-N-LOK™ | |
| 2 PLC ± 0.13 | | APPLICATION SPEC | | RESTRICTED TO | |
| 3 PLC ± - | | 114-1010 | | - | |
| 4 PLC ± - | | SIZE | | CAGE CODE | |
| ANGLES ± 0° 30' | | 114-1010 | | DRAWING NO | |
| FINISH - | | WEIGHT | | DRAWING NO | |
| | | 0.000000 | | A1 00779 C=640582 | |
| | | CUSTOMER DRAWING | | SCALE | |
| | | | | 4:1 | |
| | | | | SHEET 1 OF 1 | |
| | | | | REV S3 | |