

引き出し方向  
PULL DIRECTION



U



DETAIL U

NOTES

- 梱包数量 : 3000個 / リール  
NUMBER OF CONNECTORS : 3000 PCS/REEL.
- リードテープ長さ  
LEAD TAPE LENGTH



- カバーテープの剥離強度については、IEC60286-3に準拠。  
COVER TAPE PEEL FORCE IS DEFINED BY IEC 60286-3.
- 製品詳細寸法については、図面 5051101008-SD を参照下さい。  
DIMENSIONS OF PRODUCT, REFER TO 5051101008-SD.
- 材料 MATERIAL  
 キャリアテープ : ポリスチレン  
 トップテープ : ポリエチレンテレフタレート、ポリエチレン  
 リール : ポリスチレン<リサイクル材を含む>  
 CARRIER TAPE : POLYSTYRENE  
 TOP TAPE : POLYETHYLENE TEREPHTHALATE, POLYETHYLENE  
 REEL : POLYSTYRENE < RECYCLE MATERIAL CONTAINED >

|   |         |                        |            |                             |                 |
|---|---------|------------------------|------------|-----------------------------|-----------------|
| THIS DRAWING CONTAINS INFORMATION THAT IS PROPRIETARY TO MOLEX ELECTRONIC TECHNOLOGIES, LLC AND SHOULD NOT BE USED WITHOUT WRITTEN PERMISSION |         | CURRENT REV DESC:      |            | <b>molex</b>                |                 |
| DIMENSION UNITS   | SCALE   |                        |            |                             |                 |
| mm  | 2:1     |                        |            | 0.5 FPC ZIF 2 CONT EMBT PKG |                 |
| GENERAL TOLERANCES (UNLESS SPECIFIED)   |         | EC NO: 605617          |            | PRODUCT CUSTOMER DRAWING    |                 |
| ANGULAR TOL   | ± 3.0 ° | DRWN: JASANUMA         | 2018/10/05 | DOCUMENT NUMBER             |                 |
| 4 PLACES  | ± 0.2   | CHK'D: TRSUZUKI        | 2018/10/10 | 5051100008-SD               |                 |
| 3 PLACES  | ± 0.2   | APPR: RTAKEUCHI        | 2018/10/10 | DOC TYPE                    | DOC PART        |
| 2 PLACES  | ± 0.2   | INITIAL REVISION:      |            | PSD                         | 000             |
| 1 PLACE   | ± 0.25  | DRWN: JASANUMA         | 2018/10/05 | REVISION                    |                 |
| 0 PLACES  | ± 0.3   | APPR: RTAKEUCHI        | 2018/10/10 | A                           |                 |
| DRAFT WHERE APPLICABLE MUST REMAIN WITHIN DIMENSIONS  |         | THIRD ANGLE PROJECTION | DRAWING    | SERIES                      | MATERIAL NUMBER |
|   |         |                        | A3-SIZE    | 505110                      | SEE CHART       |
|   |         |                        |            | CUSTOMER                    | SHEET NUMBER    |
|   |         |                        |            |                             | 1 OF 3          |



|                  |      |     |            |      |      |      |      |                  |     |
|------------------|------|-----|------------|------|------|------|------|------------------|-----|
| 11.5             | ---- | 24  | 29.4       | 25.4 | 10.9 | 14.9 | 16   | 5051102096       | 20  |
|                  |      |     |            |      | 10.4 | 14.4 | 15.5 | 5051101997       | 19  |
|                  |      |     |            |      | 9.9  | 13.9 | 15   | 5051101897       | 18  |
|                  |      |     |            |      | 9.4  | 13.4 | 14.5 | 5051101797       | 17  |
|                  |      |     |            |      | 8.9  | 12.9 | 14   | 5051101697       | 16  |
|                  |      |     |            |      | 8.4  | 12.4 | 13.5 | 5051101597       | 15  |
|                  |      |     |            |      | 7.9  | 11.9 | 13   | 5051101497       | 14  |
|                  |      |     |            |      | 7.4  | 11.4 | 12.5 | 5051101397       | 13  |
|                  |      |     |            |      | 6.9  | 10.9 | 12   | 5051101297       | 12  |
|                  |      |     |            |      | 6.4  | 10.4 | 11.5 | 5051101197       | 11  |
|                  |      |     |            |      | 5.9  | 9.9  | 11   | 5051101097       | 10  |
|                  |      |     |            |      | 5.4  | 9.4  | 10.5 | 5051100997       | 9   |
|                  |      |     |            |      | 4.9  | 8.9  | 10   | 5051100897       | 8   |
| 4.4              | 8.4  | 9.5 | 5051100797 | 7    |      |      |      |                  |     |
| 3.9              | 7.9  | 9   | 5051100697 | 6    |      |      |      |                  |     |
| 3.4              | 7.4  | 8.5 | 5051100597 | 5    |      |      |      |                  |     |
| 7.5              | ---- | 16  | 21.4       | 17.4 | 2.9  | 6.9  | 8    | 5051100497       | 4   |
| H                | G    | F   | E          | D    | C    | B    | A    | EMBOSSED PACKAGE | Ckt |
| オーダー番号 ORDER No. |      |     |            |      |      |      |      |                  |     |

THIS DRAWING CONTAINS INFORMATION THAT IS PROPRIETARY TO MOLEX ELECTRONIC TECHNOLOGIES, LLC AND SHOULD NOT BE USED WITHOUT WRITTEN PERMISSION

|  |              |                            |         |                          |                 |          |              |
|--|--------------|----------------------------|---------|--------------------------|-----------------|----------|--------------|
| DIMENSION UNITS<br>mm                                | SCALE<br>2:1 | CURRENT REV DESC:          |         | <b>molex</b>             |                 |          |              |
| GENERAL TOLERANCES (UNLESS SPECIFIED)                |              | EC NO: 605617              |         |                          |                 |          |              |
| ANGULAR TOL  | ± 3.0 °      | DRWN: JASANUMA 2018/10/05  |         | PRODUCT CUSTOMER DRAWING |                 |          |              |
| 4 PLACES   | ± 0.2        | CHK'D: TRSUZUKI 2018/10/10 |         | DOCUMENT NUMBER          |                 |          |              |
| 3 PLACES   | ± 0.2        | APPR: RTAKEUCHI 2018/10/10 |         | 5051100008-SD            |                 |          |              |
| 2 PLACES   | ± 0.2        | INITIAL REVISION:          |         | DOC TYPE                 |                 |          |              |
| 1 PLACE  | ± 0.25       | DRWN: JASANUMA 2018/10/05  |         | PSD                      |                 |          |              |
| 0 PLACES   | ± 0.3        | APPR: RTAKEUCHI 2018/10/10 |         | DOC PART                 |                 |          |              |
| DRAFT WHERE APPLICABLE MUST REMAIN WITHIN DIMENSIONS |              | THIRD ANGLE PROJECTION     | DRAWING | SERIES                   | MATERIAL NUMBER | CUSTOMER | SHEET NUMBER |
|  |              |                            | A3-SIZE | 505110                   | SEE CHART       |          | 2 OF 3       |



|   |   |   |   |   |      |      |      |                  |     |
|---|---|---|---|---|------|------|------|------------------|-----|
|   |   |   |   |   | 40.9 | 44.9 | 46   | 5051108096       | 80  |
|   |   |   |   |   | 35.9 | 39.9 | 41   | 5051107096       | 70  |
|   |   |   |   |   | 34.9 | 38.9 | 40   | 5051106896       | 68  |
|   |   |   |   |   | 32.9 | 36.9 | 38   | 5051106496       | 64  |
|   |   |   |   |   | 31.4 | 35.4 | 36.5 | 5051106196       | 61  |
|   |   |   |   |   | 30.9 | 34.9 | 36   | 5051106096       | 60  |
|   |   |   |   |   | 30.4 | 34.4 | 35.5 | 5051105996       | 59  |
|   |   |   |   |   | 29.9 | 33.9 | 35   | 5051105896       | 58  |
|   |   |   |   |   | 29.4 | 33.4 | 34.5 | 5051105796       | 57  |
|   |   |   |   |   | 28.9 | 32.9 | 34   | 5051105696       | 56  |
| H | G | F | E | D | C    | B    | A    | EMBOSSED PACKAGE | Ckt |
|   |   |   |   |   |      |      |      | オーダー番号 ORDER No. |     |

|      |      |    |      |      |      |      |      |                  |     |
|------|------|----|------|------|------|------|------|------------------|-----|
| 26.2 | 52.4 | 56 | 61.4 | 57.4 | 28.4 | 32.4 | 33.5 | 5051105596       | 55  |
|      |      |    |      |      | 27.9 | 31.9 | 33   | 5051105496       | 54  |
|      |      |    |      |      | 27.4 | 31.4 | 32.5 | 5051105396       | 53  |
|      |      |    |      |      | 26.9 | 30.9 | 32   | 5051105296       | 52  |
|      |      |    |      |      | 26.4 | 30.4 | 31.5 | 5051105196       | 51  |
|      |      |    |      |      | 25.9 | 29.9 | 31   | 5051105096       | 50  |
|      |      |    |      |      | 25.4 | 29.4 | 30.5 | 5051104996       | 49  |
|      |      |    |      |      | 24.9 | 28.9 | 30   | 5051104896       | 48  |
|      |      |    |      |      | 24.4 | 28.4 | 29.5 | 5051104796       | 47  |
|      |      |    |      |      | 23.9 | 27.9 | 29   | 5051104696       | 46  |
|      |      |    |      |      | 23.4 | 27.4 | 28.5 | 5051104596       | 45  |
|      |      |    |      |      | 22.9 | 26.9 | 28   | 5051104496       | 44  |
|      |      |    |      |      | 22.4 | 26.4 | 27.5 | 5051104396       | 43  |
|      |      |    |      |      | 21.9 | 25.9 | 27   | 5051104296       | 42  |
|      |      |    |      |      | 21.4 | 25.4 | 26.5 | 5051104196       | 41  |
|      |      |    |      |      | 20.9 | 24.9 | 26   | 5051104096       | 40  |
|      |      |    |      |      | 20.4 | 24.4 | 25.5 | 5051103996       | 39  |
|      |      |    |      |      | 19.9 | 23.9 | 25   | 5051103896       | 38  |
|      |      |    |      |      | 19.4 | 23.4 | 24.5 | 5051103796       | 37  |
|      |      |    |      |      | 18.9 | 22.9 | 24   | 5051103696       | 36  |
|      |      |    |      |      | 18.4 | 22.4 | 23.5 | 5051103596       | 35  |
|      |      |    |      |      | 17.9 | 21.9 | 23   | 5051103496       | 34  |
|      |      |    |      |      | 17.4 | 21.4 | 22.5 | 5051103396       | 33  |
|      |      |    |      |      | 16.9 | 20.9 | 22   | 5051103296       | 32  |
|      |      |    |      |      | 16.4 | 20.4 | 21.5 | 5051103196       | 31  |
|      |      |    |      |      | 15.9 | 19.9 | 21   | 5051103096       | 30  |
|      |      |    |      |      | 15.4 | 19.4 | 20.5 | 5051102996       | 29  |
|      |      |    |      |      | 14.9 | 18.9 | 20   | 5051102896       | 28  |
|      |      |    |      |      | 14.4 | 18.4 | 19.5 | 5051102796       | 27  |
|      |      |    |      |      | 13.9 | 17.9 | 19   | 5051102696       | 26  |
|      |      |    |      |      | 13.4 | 17.4 | 18.5 | 5051102596       | 25  |
|      |      |    |      |      | 12.9 | 16.9 | 18   | 5051102496       | 24  |
|      |      |    |      |      | 12.4 | 16.4 | 17.5 | 5051102396       | 23  |
|      |      |    |      |      | 11.9 | 15.9 | 17   | 5051102296       | 22  |
|      |      |    |      |      | 11.4 | 15.4 | 16.5 | 5051102196       | 21  |
| H    | G    | F  | E    | D    | C    | B    | A    | EMBOSSED PACKAGE | Ckt |
|      |      |    |      |      |      |      |      | オーダー番号 ORDER No. |     |

THIS DRAWING CONTAINS INFORMATION THAT IS PROPRIETARY TO MOLEX ELECTRONIC TECHNOLOGIES, LLC AND SHOULD NOT BE USED WITHOUT WRITTEN PERMISSION

|  |         |                        |                 |
|--|---------|------------------------|-----------------|
| DIMENSION UNITS                                      | SCALE   | CURRENT REV DESC:      |                 |
| mm   | 2:1     |                        |                 |
| GENERAL TOLERANCES (UNLESS SPECIFIED)                |         |                        |                 |
| ANGULAR TOL  | ± 3.0 ° | EC NO: 605617          |                 |
| 4 PLACES   | ± 0.2   | DRWN: JASANUMA         | 2018/10/05      |
| 3 PLACES   | ± 0.2   | CHK'D: TRSUZUKI        | 2018/10/10      |
| 2 PLACES   | ± 0.2   | APPR: RTAKEUCHI        | 2018/10/10      |
| 1 PLACE  | ± 0.25  | INITIAL REVISION:      |                 |
| 0 PLACES   | ± 0.3   | DRWN: JASANUMA         | 2018/10/05      |
|  |         | APPR: RTAKEUCHI        | 2018/10/10      |
| DRAFT WHERE APPLICABLE MUST REMAIN WITHIN DIMENSIONS |         | THIRD ANGLE PROJECTION | DRAWING         |
|  |         |                        | A3-SIZE         |
|  |         | SERIES                 | MATERIAL NUMBER |
|  |         | 5051110                | SEE CHART       |
|  |         | CUSTOMER               | SHEET NUMBER    |
|  |         |                        | 3 OF 3          |

**molex**

0.5 FPC ZIF 2 CONT EMBT PKG

PRODUCT CUSTOMER DRAWING

|                 |          |          |          |
|-----------------|----------|----------|----------|
| DOCUMENT NUMBER | DOC TYPE | DOC PART | REVISION |
| 5051100008-SD   | PSD      | 000      | A        |



: PICK UP AREA



|       |      |     |      |                  |     |
|-------|------|-----|------|------------------|-----|
| 10.07 | 12.6 | 9   | 14.2 | 5051101997       | 19  |
| 9.57  | 12.1 | 8.5 | 13.7 | 5051101897       | 18  |
| 9.07  | 11.6 | 8   | 13.2 | 5051101797       | 17  |
| 8.57  | 11.1 | 7.5 | 12.7 | 5051101697       | 16  |
| 8.07  | 10.6 | 7   | 12.2 | 5051101597       | 15  |
| 7.57  | 10.1 | 6.5 | 11.7 | 5051101497       | 14  |
| 7.07  | 9.6  | 6   | 11.2 | 5051101397       | 13  |
| 6.57  | 9.1  | 5.5 | 10.7 | 5051101297       | 12  |
| 6.07  | 8.6  | 5   | 10.2 | 5051101197       | 11  |
| 5.57  | 8.1  | 4.5 | 9.7  | 5051101097       | 10  |
| 5.07  | 7.6  | 4   | 9.2  | 5051100997       | 9   |
| 4.57  | 7.1  | 3.5 | 8.7  | 5051100897       | 8   |
| 4.07  | 6.6  | 3   | 8.2  | 5051100797       | 7   |
| 3.57  | 6.1  | 2.5 | 7.7  | 5051100697       | 6   |
| 3.07  | 5.6  | 2   | 7.2  | 5051100597       | 5   |
| 2.57  | 5.1  | 1.5 | 6.7  | 5051100497       | 4   |
| D     | C    | B   | A    | EMBOSSED PACKAGE | Ckt |
|       |      |     |      | オーダー番号 ORDER No. |     |

THIS DRAWING CONTAINS INFORMATION THAT IS PROPRIETARY TO MOLEX ELECTRONIC TECHNOLOGIES, LLC AND SHOULD NOT BE USED WITHOUT WRITTEN PERMISSION

|  |                     |                        |         |                 |                 |          |
|--|---------------------|------------------------|---------|-----------------|-----------------|----------|
| DIMENSION UNITS<br><b>mm</b>                         | SCALE<br><b>8:1</b> | CURRENT REV DESC:      |         | <b>molex</b>    |                 |          |
| GENERAL TOLERANCES (UNLESS SPECIFIED)                |                     | EC NO: 720907          |         |                 |                 |          |
| ANGULAR TOL  | ± 3.0 °             | DRWN: RAJMOK           |         | 2022/09/09      |                 |          |
| 4 PLACES   | ± 0.2               | CHK'D: YNUKANOBU       |         | 2022/09/22      |                 |          |
| 3 PLACES   | ± 0.2               | APPR: YNAITO           |         | 2022/09/22      |                 |          |
| 2 PLACES   | ± 0.2               | INITIAL REVISION:      |         | DOCUMENT NUMBER |                 |          |
| 1 PLACE  | ± 0.25              | DRWN: JASANUMA         |         | 2018/10/05      |                 | DOC TYPE |
| 0 PLACES   | ± 0.3               | APPR: RTAKEUCHI        |         | 2018/10/10      |                 | DOC PART |
| DRAFT WHERE APPLICABLE MUST REMAIN WITHIN DIMENSIONS |                     | THIRD ANGLE PROJECTION | DRAWING | SERIES          | MATERIAL NUMBER | CUSTOMER |
|  |                     |                        | A3-SIZE | 505110          | 5051101008-SD   | PSD      |
|  |                     |                        |         | REVISION        | 000             | C        |
|  |                     |                        |         | SHEET NUMBER    |                 | 1 OF 4   |

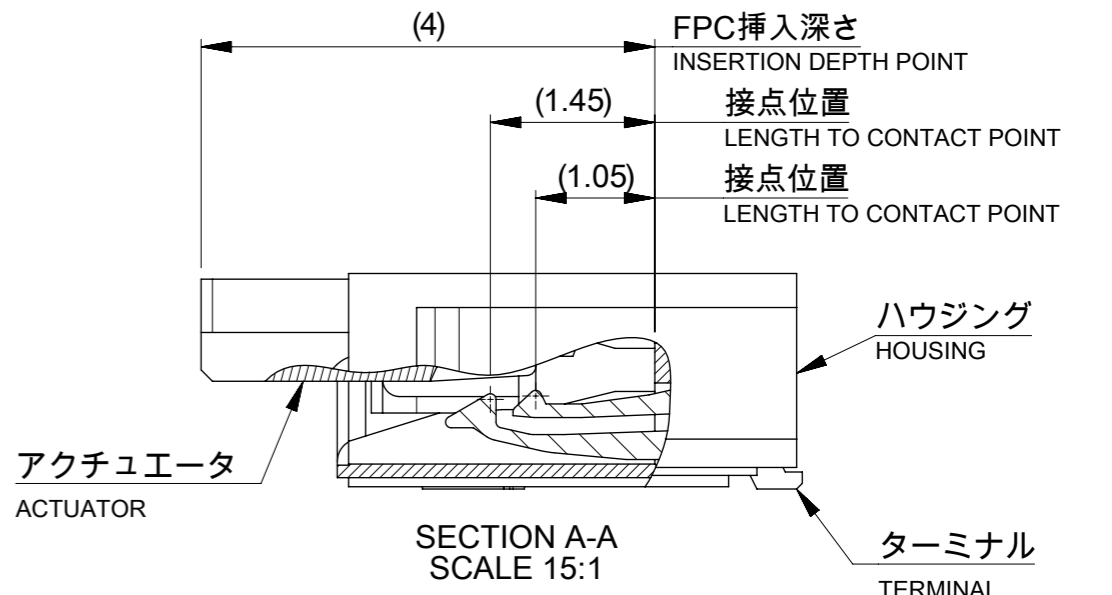

|      |      |      |      |                  |     |      |      |      |      |                  |     |      |      |      |      |                  |     |      |      |      |      |                  |     |
|------|------|------|------|------------------|-----|------|------|------|------|------------------|-----|------|------|------|------|------------------|-----|------|------|------|------|------------------|-----|
| 40.5 | 43.1 | 39.5 | 44.7 | 5051108096       | 80  | 25   | 27.6 | 24   | 29.2 | 5051104996       | 49  | 20   | 22.6 | 19   | 24.2 | 5051103996       | 39  | 15   | 17.6 | 14   | 19.2 | 5051102996       | 29  |
| 35.5 | 38.1 | 34.5 | 39.7 | 5051107096       | 70  | 24.5 | 27.1 | 23.5 | 28.7 | 5051104896       | 48  | 19.5 | 22.1 | 18.5 | 23.7 | 5051103896       | 38  | 14.5 | 17.1 | 13.5 | 18.7 | 5051102896       | 28  |
| 34.5 | 37.1 | 33.5 | 38.7 | 5051106896       | 68  | 24   | 26.6 | 23   | 28.2 | 5051104796       | 47  | 19   | 21.6 | 18   | 23.2 | 5051103796       | 37  | 14   | 16.6 | 13   | 18.2 | 5051102796       | 27  |
| 32.5 | 35.1 | 31.5 | 36.7 | 5051106496       | 64  | 23.5 | 26.1 | 22.5 | 27.7 | 5051104696       | 46  | 18.5 | 21.1 | 17.5 | 22.7 | 5051103696       | 36  | 13.5 | 16.1 | 12.5 | 17.7 | 5051102696       | 26  |
| 31   | 33.6 | 30   | 35.2 | 5051106196       | 61  | 23   | 25.6 | 22   | 27.2 | 5051104596       | 45  | 18   | 20.6 | 17   | 22.2 | 5051103596       | 35  | 13   | 15.6 | 12   | 17.2 | 5051102596       | 25  |
| 30.5 | 33.1 | 29.5 | 34.7 | 5051106096       | 60  | 22.5 | 25.1 | 21.5 | 26.7 | 5051104496       | 44  | 17.5 | 20.1 | 16.5 | 21.7 | 5051103496       | 34  | 12.5 | 15.1 | 11.5 | 16.7 | 5051102496       | 24  |
| 30   | 32.6 | 29   | 34.2 | 5051105996       | 59  | 22   | 24.6 | 21   | 26.2 | 5051104396       | 43  | 17   | 19.6 | 16   | 21.2 | 5051103396       | 33  | 12   | 14.6 | 11   | 16.2 | 5051102396       | 23  |
| 29.5 | 32.1 | 28.5 | 33.7 | 5051105896       | 58  | 21.5 | 24.1 | 20.5 | 25.7 | 5051104296       | 42  | 16.5 | 19.1 | 15.5 | 20.7 | 5051103296       | 32  | 11.5 | 14.1 | 10.5 | 15.7 | 5051102296       | 22  |
| 29   | 31.6 | 28   | 33.2 | 5051105796       | 57  | 21   | 23.6 | 20   | 25.2 | 5051104196       | 41  | 16   | 18.6 | 15   | 20.2 | 5051103196       | 31  | 11   | 13.6 | 10   | 15.2 | 5051102196       | 21  |
| 28.5 | 31.1 | 27.5 | 32.7 | 5051105696       | 56  | 20.5 | 23.1 | 19.5 | 24.7 | 5051104096       | 40  | 15.5 | 18.1 | 14.5 | 19.7 | 5051103096       | 30  | 10.5 | 13.1 | 9.5  | 14.7 | 5051102096       | 20  |
| 28   | 30.6 | 27   | 32.2 | 5051105596       | 55  | D    | C    | B    | A    | EMBOSSED PACKAGE | Ckt | D    | C    | B    | A    | EMBOSSED PACKAGE | Ckt | D    | C    | B    | A    | EMBOSSED PACKAGE | Ckt |
| 27.5 | 30.1 | 26.5 | 31.7 | 5051105496       | 54  |      |      |      |      | オーダー番号 ORDER No. |     |      |      |      |      | オーダー番号 ORDER No. |     |      |      |      |      | オーダー番号 ORDER No. |     |
| 27   | 29.6 | 26   | 31.2 | 5051105396       | 53  |      |      |      |      |                  |     |      |      |      |      |                  |     |      |      |      |      |                  |     |
| 26.5 | 29.1 | 25.5 | 30.7 | 5051105296       | 52  |      |      |      |      |                  |     |      |      |      |      |                  |     |      |      |      |      |                  |     |
| 26   | 28.6 | 25   | 30.2 | 5051105196       | 51  |      |      |      |      |                  |     |      |      |      |      |                  |     |      |      |      |      |                  |     |
| 25.5 | 28.1 | 24.5 | 29.7 | 5051105096       | 50  |      |      |      |      |                  |     |      |      |      |      |                  |     |      |      |      |      |                  |     |
| D    | C    | B    | A    | EMBOSSED PACKAGE | Ckt |      |      |      |      |                  |     |      |      |      |      |                  |     |      |      |      |      |                  |     |
|      |      |      |      | オーダー番号 ORDER No. |     |      |      |      |      |                  |     |      |      |      |      |                  |     |      |      |      |      |                  |     |

THIS DRAWING CONTAINS INFORMATION THAT IS PROPRIETARY TO MOLEX ELECTRONIC TECHNOLOGIES, LLC AND SHOULD NOT BE USED WITHOUT WRITTEN PERMISSION

|  |        |                   |                 |
|--|--------|-------------------|-----------------|
| DIMENSION UNITS                                      | SCALE  | CURRENT REV DESC: |                 |
| mm   | 8:1    |                   |                 |
| GENERAL TOLERANCES (UNLESS SPECIFIED)                |        |                   |                 |
| ANGULAR TOL  | ± 3.0° |                   |                 |
| 4 PLACES   | ± 0.2  | EC NO: 720907     | 2022/09/09      |
| 3 PLACES   | ± 0.2  | DRWN: RAJMOK      | 2022/09/22      |
| 2 PLACES   | ± 0.2  | CHK'D: YNUKANOBU  | 2022/09/22      |
| 1 PLACE  | ± 0.25 | APPR: YNAITO      | 2022/09/22      |
| 0 PLACES   | ± 0.3  | INITIAL REVISION: |                 |
| DRAFT WHERE APPLICABLE MUST REMAIN WITHIN DIMENSIONS |        | DRWN: JASANUMA    | 2018/10/05      |
| THIRD ANGLE PROJECTION                               |        | APPR: RTAKEUCHI   | 2018/10/10      |
| DRAWING  |        | SERIES            | MATERIAL NUMBER |
| A3-SIZE  |        | 505110            | 5051101008-SD   |
| CUSTOMER   |        | DOCUMENT NUMBER   | DOC TYPE        |
|  |        | 5051101008-SD     | PSD             |
| SHEET NUMBER   |        | DOC PART          | REVISION        |
| 2 OF 4   |        | 000               | C               |



適合FPC/FFC推奨寸法  
 APPLICABLE FPC/FFC RECOMMENDED DIMENSION

( ) : FFCに適用  
 ( ) : APPLY TO FFC



適合FPC/FFC推奨寸法  
 APPLICABLE FPC/FFC RECOMMENDED DIMENSION

( ) : FFCに適用  
 ( ) : APPLY TO FFC

\*1 : 125°Cを超える環境下で使用する場合に適用。  
 Apply when use in over 125 deg.C environment.

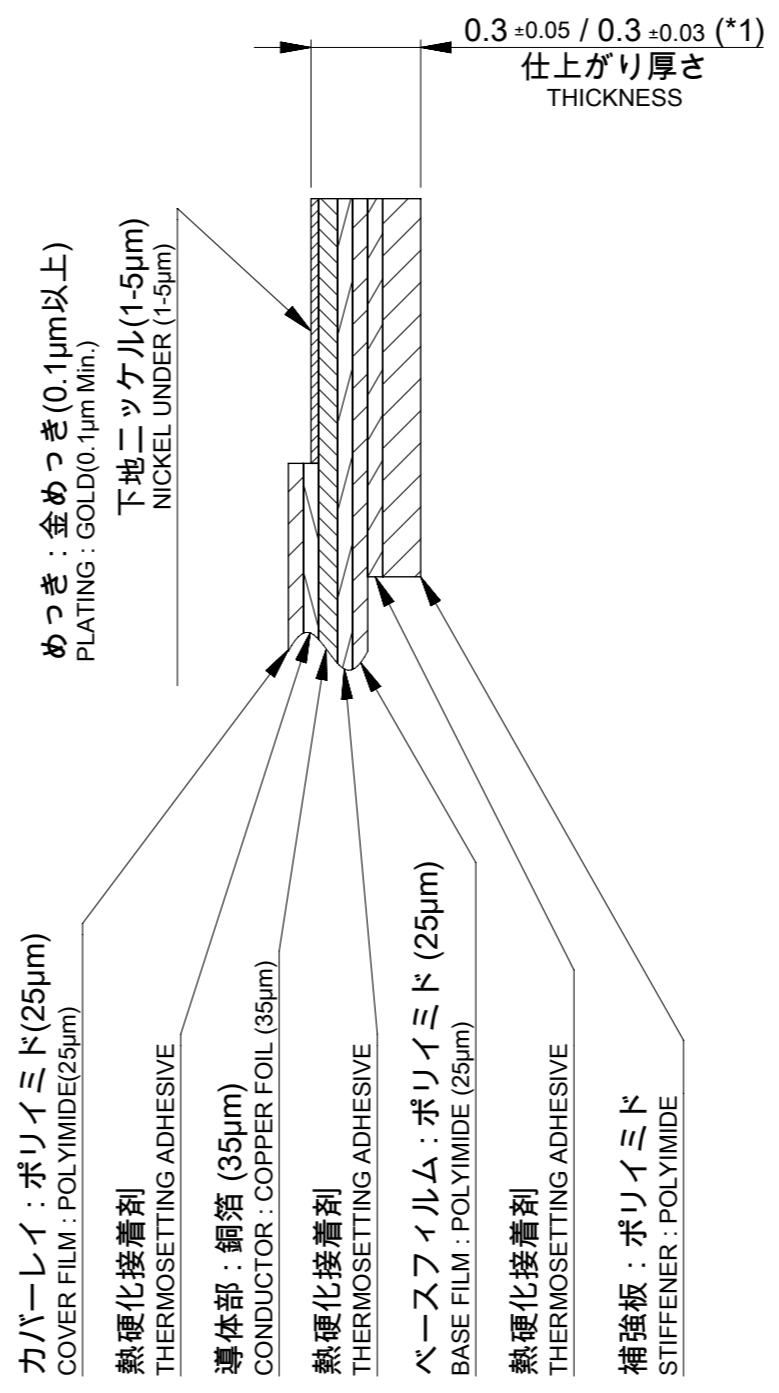

FPC構成推奨仕様  
 STRUCTURE OF FPC

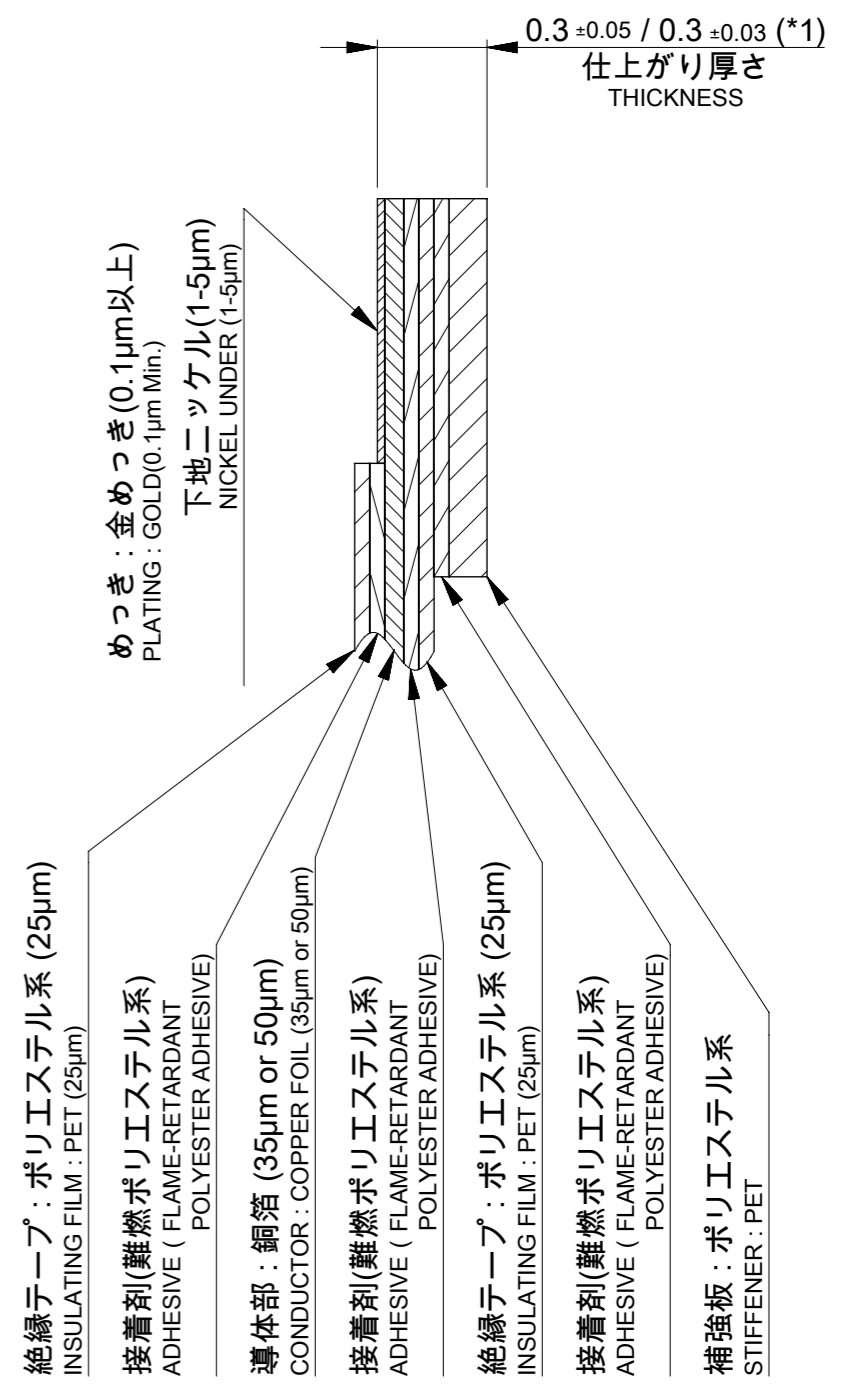

FFC構成推奨仕様  
 STRUCTURE OF FFC

|   |  |        |  |                        |  |            |  |               |  |                            |  |
|---|--|--------|--|------------------------|--|------------|--|---------------|--|----------------------------|--|
| THIS DRAWING CONTAINS INFORMATION THAT IS PROPRIETARY TO MOLEX ELECTRONIC TECHNOLOGIES, LLC AND SHOULD NOT BE USED WITHOUT WRITTEN PERMISSION |  |        |  |                        |  |            |  |               |  |                            |  |
| DIMENSION UNITS   |  | SCALE  |  | CURRENT REV DESC:      |  |            |  |               |  |                            |  |
| mm  |  | 10:1   |  |                        |  |            |  |               |  |                            |  |
| GENERAL TOLERANCES (UNLESS SPECIFIED)   |  |        |  |                        |  |            |  |               |  |                            |  |
| ANGULAR TOL ± 3.0°  |  |        |  |                        |  |            |  |               |  |                            |  |
| 4 PLACES  |  | ± 0.2  |  | EC NO: 720907          |  |            |  |               |  |                            |  |
| 3 PLACES  |  | ± 0.2  |  | DRWN: RAJMOK           |  | 2022/09/09 |  |               |  |                            |  |
| 2 PLACES  |  | ± 0.2  |  | CHK'D: YNUKANOBU       |  | 2022/09/22 |  |               |  |                            |  |
| 1 PLACE   |  | ± 0.25 |  | APPR: YNAITO           |  | 2022/09/22 |  |               |  |                            |  |
| 0 PLACES  |  | ± 0.3  |  | INITIAL REVISION:      |  |            |  |               |  |                            |  |
|   |  |        |  | DRWN: JASANUMA         |  | 2018/10/05 |  |               |  |                            |  |
|   |  |        |  | APPR: RTAKEUCHI        |  | 2018/10/10 |  |               |  |                            |  |
| DRAFT WHERE APPLICABLE MUST REMAIN WITHIN DIMENSIONS  |  |        |  | THIRD ANGLE PROJECTION |  | DRAWING    |  | SERIES        |  | DOCUMENT NUMBER            |  |
|   |  |        |  | A3-SIZE                |  | 505110     |  | 5051101008-SD |  | DOC TYPE DOC PART REVISION |  |
|   |  |        |  |                        |  |            |  | PSD 000       |  | C                          |  |
|   |  |        |  |                        |  |            |  |               |  | SHEET NUMBER               |  |
|   |  |        |  |                        |  |            |  |               |  | 3 OF 4                     |  |

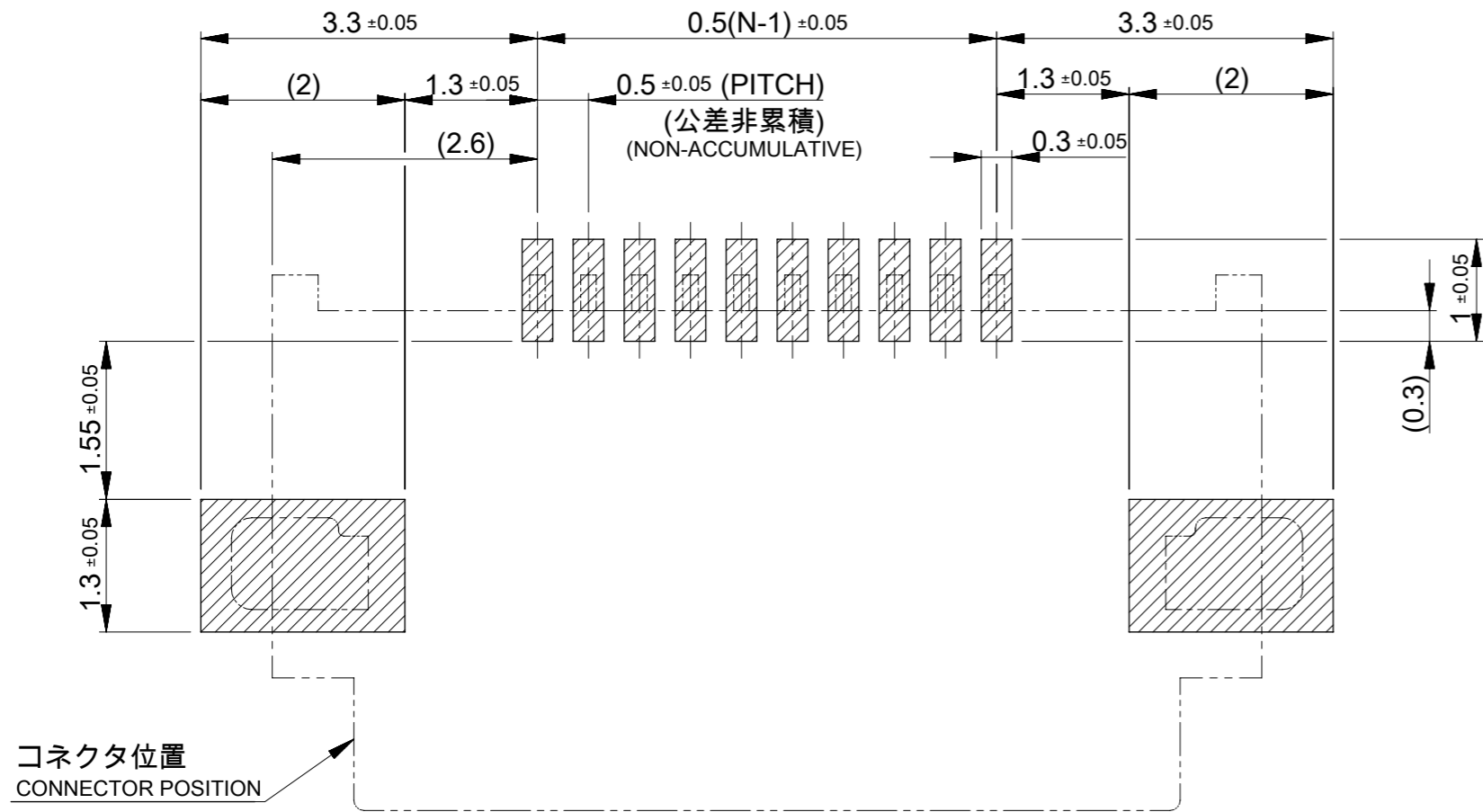

推奨基板レイアウト  
RECOMMENDED P.W.B PATTERN LAYOUT

参考マスク厚 : 100µm  
REFERENCE SCREEN THICKNESS : 100µm  
参考マスク開口率 : 100%  
REFERENCE SCREEN OPEN RATIO : 100%

FPC/FFCについて ABOUT FPC/FFC

打ち抜き方向は導体側から補強板側を推奨します。  
導体部については軟箔銅35µmまたは50µmを推奨します。  
FFCに規定された定格温度がFFC単体前提である場合が御座います。  
コネクタと組み合わせた実使用において、接着層が劣化するなどの信頼性を満足できないケースを回避するため、  
実機での評価/確認をお願いいたします。  
RECOMMENDED PUNCHING DIRECTION : FROM CONDUCTOR SIDE TO STIFFENER SIDE  
RECOMMENDED CONDUCTOR SPEC : SOFT COPPER FOIL  
RECOMMENDED CONDUCTOR THICKNESS : 35 MICROMETER OR 50 MICROMETER  
NOTE : WHEN ACTUALLY USING IT WITH CONNECTOR, PLEASE DO THE EVALUATION AND THE CONFIRMATION WITH AN ACTUAL EQUIPMENT TO EVADE THE CASE WHERE RELIABILITY CANNOT BE FILLED (THE ADHESIVE LINE OF FFC IS DETERIORATED ETC.)

FPCについて ABOUT FPC

補強フィルム材質はポリイミドを推奨します。ベースフィルムは25µmを推奨します。  
接着剤は熱硬化接着剤を推奨します。  
尚、接着剤の接点部への付着は導通不良の原因になりますので、染み出しが無い様お願い致します。  
RECOMMENDED STIFFENER MATERIAL : POLYIMIDE  
RECOMMENDED BASE FILM THICKNESS : 25 MICROMETER  
RECOMMENDED ADHESIVE : THERMOSETTING ADHESIVE  
NOTE : PLEASE PUT APPROPRIATE AMOUNT OF ADHESIVE ON ADHEREND BECAUSE THERE IS A POSSIBILITY THAT THE EXTRA ADHESIVE CAUSES THE DEFECT IN ELECTRICAL CONTINUITY.

注記 NOTES

1. 使用材料 MATERIAL

ハウジング : 液晶ポリマー ガラス充填、UL94V-0 (ベージュ)  
HOUSING : LIQUID CRYSTAL POLYMER GLASS FILLED, UL94V-0 (BEIGE)  
アクチュエータ : ポリアミド ガラス充填、UL94V-0 (黒)  
ACTUATOR : POLYAMIDE GLASS FILLED, UL94V-0 (BLACK)  
ターミナル : 銅合金(t=0.15)  
TERMINAL : COPPER ALLOY  
金具 : リン青銅 (t=0.15)  
FITTING NAIL : PHOSPHOR BRONZE

2. めっき仕様 PLATING

ターミナル TERMINAL  
コンタクト部 : 部分金めっき (0.05µm以上)  
CONTACT AREA : SEPARATED GOLD PLATING (0.05µm MINIMUM)  
テール部 : 部分金めっき  
SOLDER TAIL AREA : SEPARATED GOLD PLATING  
下地:ニッケルめっき (1.0µm以上)  
UNDERPLATE : NICKEL OVERALL (1.0µm MINIMUM)  
金具 FITTING NAIL  
錫めっき (1.0µm以上)  
TIN PLATING (1.0µm MINIMUM)  
下地:ニッケルめっき (1.0µm以上)  
UNDER PLATING : NICKEL PLATING (1.0µm MINIMUM)

3. エンボステープ梱包時は、アクチュエータが閉じた状態とする。  
IN THE PACKAGE, ACTUATOR OF PART SHOULD BE CLOSED.

△4 パターン剥離止め用金具  
FITTING NAIL FOR PREVENTING PEELING OF P.W.B. PATTERN.

△5 R0.3はFPC/FFC導体部にかからないこと。  
R0.3 MUST NOT BE OVERLAPPED TO PATTERN OF FPC/FFC.

6. N : 極数 N : CIRCUIT

7. テールと金具を併せた平坦度は0.1mm以下とする。  
TAILS AND NAILS COPLANALITY TO BE 0.1mm MAXIMUM.

|   |  |       |  |                             |  |         |  |        |  |              |  |
|---|--|-------|--|-----------------------------|--|---------|--|--------|--|--------------|--|
| THIS DRAWING CONTAINS INFORMATION THAT IS PROPRIETARY TO MOLEX ELECTRONIC TECHNOLOGIES, LLC AND SHOULD NOT BE USED WITHOUT WRITTEN PERMISSION |  |       |  |                             |  |         |  |        |  |              |  |
| DIMENSION UNITS   |  | SCALE |  | CURRENT REV DESC:           |  |         |  |        |  |              |  |
| mm  |  | 15:1  |  |                             |  |         |  |        |  |              |  |
| GENERAL TOLERANCES (UNLESS SPECIFIED)   |  |       |  |                             |  |         |  |        |  |              |  |
| ANGULAR TOL ± 3.0°  |  |       |  | 0.5 FPC ZIF 2 CONT HSG ASSY |  |         |  |        |  |              |  |
| 4 PLACES ± 0.2  |  |       |  | PRODUCT CUSTOMER DRAWING    |  |         |  |        |  |              |  |
| 3 PLACES ± 0.2  |  |       |  | DOCUMENT NUMBER             |  |         |  |        |  |              |  |
| 2 PLACES ± 0.2  |  |       |  | 5051101008-SD               |  |         |  |        |  |              |  |
| 1 PLACE ± 0.25  |  |       |  | DOC TYPE                    |  |         |  |        |  |              |  |
| 0 PLACES ± 0.3  |  |       |  | PSD                         |  |         |  |        |  |              |  |
| DRAFT WHERE APPLICABLE MUST REMAIN WITHIN DIMENSIONS  |  |       |  | THIRD ANGLE PROJECTION      |  | DRAWING |  | SERIES |  | SHEET NUMBER |  |
|   |  |       |  |                             |  | A3-SIZE |  | 505110 |  | 4 OF 4       |  |