

# CPI0806J1R2R-10

**UNCONTROLLED DOCUMENT**

## PHYSICAL DIMENSIONS:

A	2.00 [.079]	+ 0.15 [.006]
B	1.60 [.063]	+ 0.15 [.006]
C	0.90 [.035]	+ 0.10 [.004]
D	0.50 [.020]	+ 0.20 [.008]

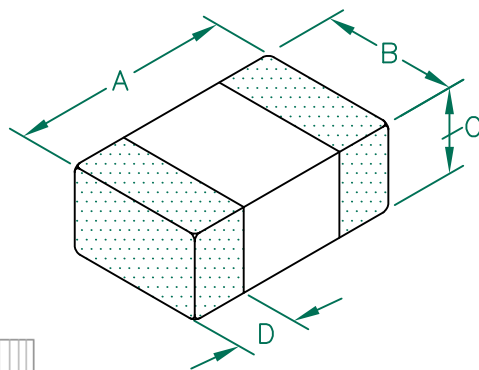

## ELECTRICAL CHARACTERISTICS:

	L ( $\mu\text{H}$ ) @ 1MHz $\pm 20\%$	DCR ( $\Omega$ ) $\pm 30\%$	I (Max)
Nom	1.20	0.160	
Min	0.96	0.112	
Max	1.44	0.208	1400mA

### NOTES: UNLESS OTHERWISE SPECIFIED

1. TAPED AND REELED per CURRENT EIA SPECIFICATIONS  
7" REELS, 3000 PCS/REEL, EMBOSSED PLASTIC TAPE.
2. TERMINATION FINISH IS 100% MATTE Sn OVER Ni.
3. COMPONENTS SHOULD BE ADEQUATELY PREHEATED BEFORE SOLDERING.
4. I (MAX.) IS BASED ON THE MAXIMUM SUSTAINED CURRENT APPLIED WHILE MAINTAINING A MAXIMUM TEMPERATURE RISE OF 40°C OVER AMBIENT.
5. OPERATION TEMPERATURE TEMP: -55°C~+125°C (INCLUDING SELF-HEATING)

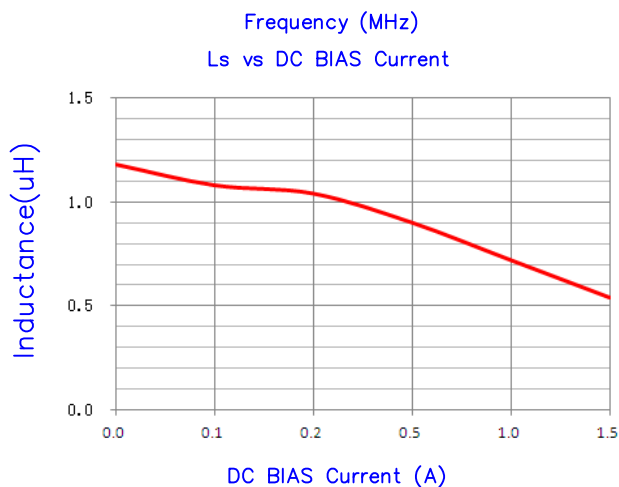
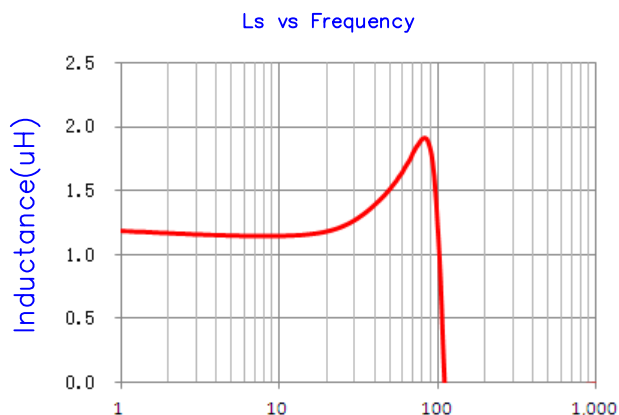

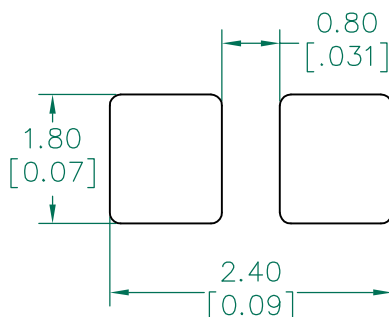

## LAND PATTERNS FOR REFLOW SOLDERING

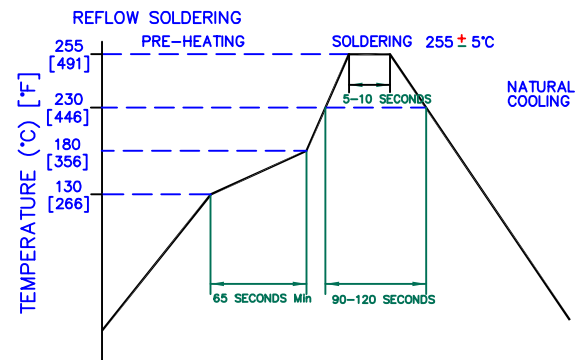

(For wave soldering, add 0.763 [0.030] to this dimension)

## RECOMMENDED SOLDERING CONDITIONS



DIMENSIONS ARE IN mm [INCHES].				This print is the property of Laird Tech. and is loaned in confidence subject to return upon request and with the understanding that no copies shall be made without the written consent of Laird Tech. All rights to design or invention are reserved.				
								
				PROJECT/PART NUMBER:		REV:	PART TYPE:	DRAWN BY:
				CPI0806J1R2R-10		B	CO-FIRE	QU
				DATE: 03/01/11		SCALE: NTS		SHEET:
				CAD #		TOOL #		2 of 2
REV	DESCRIPTION	DATE	INT	CPI0806J1R2R-10-B				