

| REVISIONS | | | |
|-----------|-----------------|----------|----------|
| REV | DESCRIPTION | DATE | APPROVED |
| A | INITIAL RELEASE | 01/19/10 | D.N. |

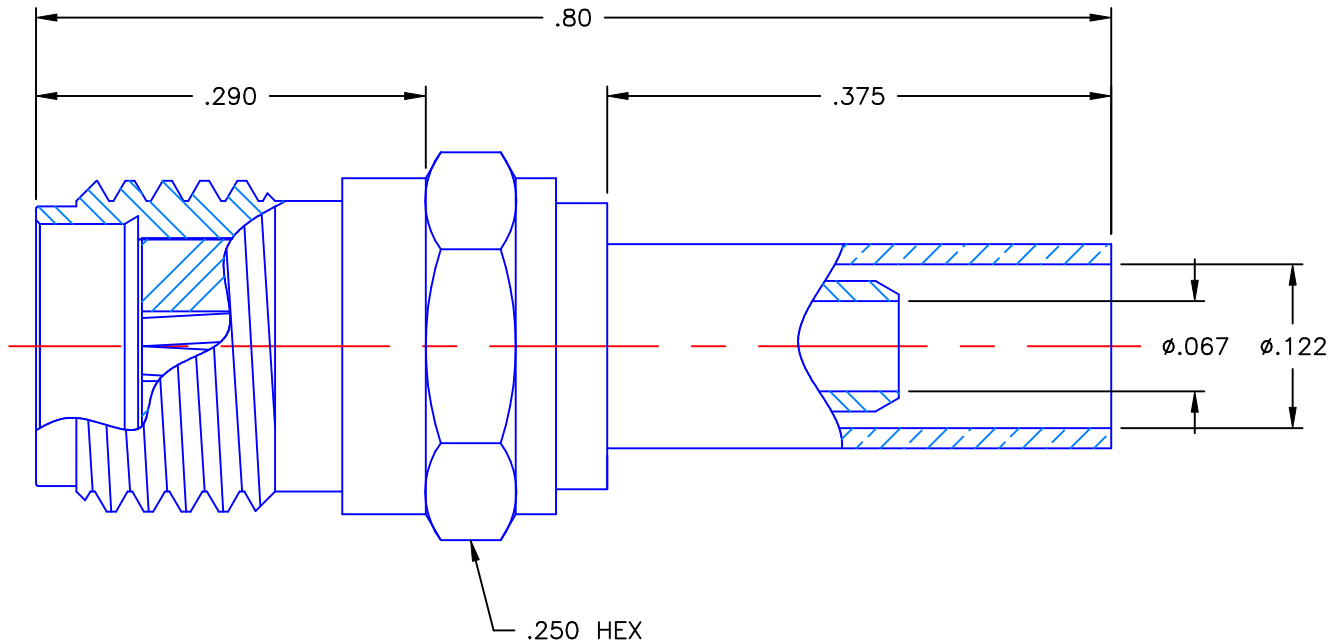

NOTES:

MATERIALS:

1. BODY = STAINLESS STEEL PER ASTM A582, ALLOY 303, CONDITION "A".
2. INSULATOR = VIRGIN WHITE TEFLON PER ASTM D1710, GRADE 1, TYPE I, CLASS "B".
3. CONTACT = BERYLLIUM COPPER PER ASTM B196, ALLOY C17300, TEMPER TD04.
4. CRIMP SLEEVE = SEAMLESS LOWLEAD BRASS TUBE, ALLOY 330, SOFT ANNEAL TEMPER, .025/.060 GRAIN SIZE OR SEAMLESS COPPER TUBE PER ASTM B75, TYPE C12000, TEMPER: LIGHT ANNEAL 050 EXCEPT YIELD STRENGTH.
5. SHRINK SLEEVE = THEROFIT SCL, BLACK (NOT SHOWN).

FINISHES:

1. BODY = PASSIVATE PER QQ-P-35, TYPE VI.
2. CONTACT = GOLD PLATE PER MIL-G-45204, TYPE II, CLASS 1, GRADE C, OVER .00010 TO .00020 STRESS FREE SULFAMATE NICKEL PER QQ-N-290.
3. CRIMP SLEEVE = NICKEL PLATE PER QQ-N-290, CLASS 1, GRADE G, EXCEPT .0001 TO .0002 THICK OVER .00005 TO .0001 THICK COPPER PER MIL-C-14550.

Property of Radiall Incorporated
 This document cannot be reproduced or
 communicated to a third party without prior
 written permission of RADIALL Incorporated.

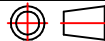
| | | | | |
|---|-------|--|----------|--|
| UNLESS OTHERWISE SPECIFIED DIMENSIONS ARE IN INCHES TOLERANCES ON | | DWN: | DATE |  APPLIED ENGINEERING PRODUCTS 104 John W. Murphy Dr. New Haven, CT 06513 |
| | | D.N. | 01/19/10 | |
| DECIMAL | ANGLE | CHKD: | DATE | SMA STRAIGHT JACK CRIMP TYPE FOR RG-316 & SIMILAR CABLES |
| | | A.D.M. | 01/19/10 | |
| REFERENCE: | | APVD: | DATE | SIZE A FSCM NO. 19505 DWG NO. 9002-9023-003 REV A |
| | | J.M. | 01/19/10 | |
| ORIGINATOR: D.N. DATE: 01/19/10 | | MATERIALS & FINISHES: SEE NOTES | | SCALE 7:1 THIRD ANGLE PROJECTION  SHEET 1 OF 1 |

9002-9023-003