



**ZMOTIONL200ZCOG**

# **ZMOTION® 20-Pin Detection and Control Development Kit**

**User Manual**

UM023902-1013



**Warning:** DO NOT USE THIS PRODUCT IN LIFE SUPPORT SYSTEMS.

---

### **LIFE SUPPORT POLICY**

ZILOG'S PRODUCTS ARE NOT AUTHORIZED FOR USE AS CRITICAL COMPONENTS IN LIFE SUPPORT DEVICES OR SYSTEMS WITHOUT THE EXPRESS PRIOR WRITTEN APPROVAL OF THE PRESIDENT AND GENERAL COUNSEL OF ZILOG CORPORATION.

### **As used herein**

Life support devices or systems are devices which (a) are intended for surgical implant into the body, or (b) support or sustain life and whose failure to perform when properly used in accordance with instructions for use provided in the labeling can be reasonably expected to result in a significant injury to the user. A critical component is any component in a life support device or system whose failure to perform can be reasonably expected to cause the failure of the life support device or system or to affect its safety or effectiveness.

### **Document Disclaimer**

©2013 Zilog Inc. All rights reserved. Information in this publication concerning the devices, applications, or technology described is intended to suggest possible uses and may be superseded. ZILOG, INC. DOES NOT ASSUME LIABILITY FOR OR PROVIDE A REPRESENTATION OF ACCURACY OF THE INFORMATION, DEVICES, OR TECHNOLOGY DESCRIBED IN THIS DOCUMENT. ZILOG ALSO DOES NOT ASSUME LIABILITY FOR INTELLECTUAL PROPERTY INFRINGEMENT RELATED IN ANY MANNER TO USE OF INFORMATION, DEVICES, OR TECHNOLOGY DESCRIBED HEREIN OR OTHERWISE. The information contained within this document has been verified according to the general principles of electrical and mechanical engineering.

ZMOTION and Z8 Encore! XP are registered trademarks of Zilog Inc. All other product or service names are the property of their respective owners.

---

# Revision History

Each instance in the table below reflects a change to this document from its previous edition. To learn more, refer to the corresponding pages and appropriate links in the table below.

---

<b>Date</b>	<b>Revision Level</b>	<b>Description</b>	<b>Page</b>
Oct 2013	02	Deleted references to CD-ROM. All software and documentation is available free from the Zilog Store.	n/a
Mar 2012	01	Original issue	All

---

---

# Table of Contents

Revision History . . . . .	iii
Introduction . . . . .	1
Kit Contents . . . . .	1
Hardware . . . . .	1
Supported Operating Systems . . . . .	2
Safeguards . . . . .	3
Download and Install the ZDSII Software and Documentation . . . . .	3
Download and Install the Code and Documentation . . . . .	3
Safeguards . . . . .	5
ZMOTION 20-Pin Detection and Control Development Board . . . . .	6
Features . . . . .	6
MCU Features . . . . .	6
ZMOTION 20-Pin Detection and Control Development Kit Lenses and Pyroelectric Sensors . . . . .	7
Pyroelectric Sensor Options . . . . .	7
Lens Mounting Options . . . . .	8
Attaching the PIR Sensor Lens . . . . .	9
Attaching the Circuit Board Lens . . . . .	9
Assembling the Circular Lens Holder . . . . .	10
Assembling the Flat Lens Holder . . . . .	13
Connecting the USB SmartCable . . . . .	15
Running the Sample Project . . . . .	16
ZMOTION 20-Pin Development Kit Application Software . . . . .	19
Making Changes to the ZMOTION_Serial_Config Project . . . . .	21
Appendix A. Installing the USB SmartCable Driver . . . . .	23
Windows 7 32/64 Systems . . . . .	23
Windows Vista 32/64 Systems . . . . .	24
Windows XP Systems . . . . .	24
Appendix B. Installing the FTDI USB-to-UART Driver . . . . .	26
Appendix C. Schematic Diagrams . . . . .	28
Customer Support . . . . .	30

---

# Introduction

Zilog's ZMOTION 20-Pin Development Kit provides a general-purpose platform for evaluating the capabilities and operation of the ZMOTION 20-Pin Detection and Control Family of microcontrollers featuring Zilog's passive infrared (PIR) technology. The family includes a series of high-performance microcontrollers with integrated motion detection algorithms. A variety of included lenses and pyroelectric sensors demonstrate the flexibility of the integrated motion detection algorithms to provide the best possible performance for a range of lighting, detection and control applications.

---

► **Note:** This user manual acquaints users with Zilog's ZMOTION 20-Pin Detection and Control Development Kit Revision B or later.

---

The Z8FS040 MCU, a prominent member of the ZMOTION 20-Pin Detection and Control Family, combines the programmability and rich peripheral set of Zilog's Flash Z8 Encore! XP® Family of MCUs with built-in motion detection software algorithms to provide the functions necessary for PIR motion detection applications. These motion detection algorithms comprise Zilog's PIR technology and run in the background while control and status of the motion detection engine is accessed through a software Application Programmer Interface (API). As a result, the designer can create his or her own application-specific software while taking advantage of Zilog's ZMOTION Motion Detection Technology.

Within this kit, API settings are provided to match the Engine operation to each of the lens and pyroelectric sensor combinations provided.

To learn more about the ZMOTION MCU, including functional differences between the 8- and 20-pin versions, refer to the [ZMOTION Detection and Control Product Specification \(PS0285\)](#), available free for download from the Zilog website.

## Kit Contents

The ZMOTION 20-Pin Detection and Control Development Kit contains the following hardware, software and documentation:

### Hardware

- ZMOTION 20-Pin Development Board
- USB SmartCable Debugger
- 0.9" Focal Flat Lens Holder
- 0.77" Focal Circular Lens Holder
- Selection of lenses

- Selection of pyroelectric sensors, including a RE200B-P sensor installed on the Board
- Mini-USB serial cable
- Wall-mount mini-USB 5V DC power supply<sup>1</sup>
- An assortment of mounting hardware

The contents of the kit are shown in Figure 1.

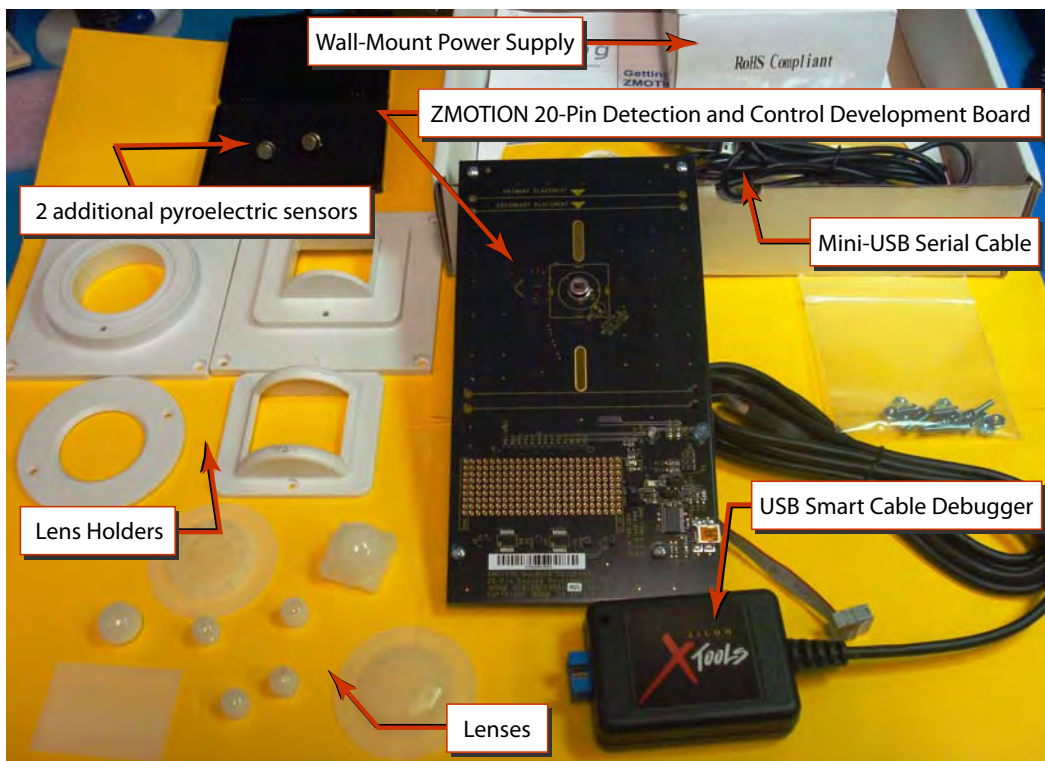

Figure 1. ZMOTION 20-Pin Detection and Control Development Kit Components

## Supported Operating Systems

The software and documentation for this kit supports Microsoft Windows 7 (32-bit/64-bit), Windows Vista (32-bit/64-bit) and Windows XP.

---

1. Zilog recommends using only the power supply provided in the ZMOTION 20-Pin Detection and Control Development Kit.

---

## Safeguards

The following precaution must be observed when working with the devices described in this document.



**Caution:** Always use a grounding strap to prevent damage resulting from electrostatic discharge (ESD).

---

## Download and Install the ZDSII Software and Documentation

Prior to connecting the ZMOTION Development Board to your PC, observe the following procedure.

1. Download ZDS II for Z8 Encore! v5.0.0 (or later) from the Downloadable Software category in the [Zilog Store](#).
2. Run the software installation file and follow the on-screen instructions to install ZDS II.

## Download and Install the Code and Documentation

ZMOTION software and documentation is available as a downloadable file from the Zilog Store. Observe the following brief procedure to download and install your ZMOTION software.

1. In the [Zilog Store](#), under Categories, click **Downloadable Software** to present a list of the available software in the Zilog Store. In this list, click **ZMOTIONL200ZCOG Software and Documentation**; the Product ID for this software is SD00026. On the Product Details page that appears next, click the blue **Add to Cart** button and complete the checkout process to download the ZMOTION software and documentation files to your hard drive.



**Note:** If you're a first-time visitor to the Zilog Store, you will first be required to register as a Zilog Store user before downloading your software. Returning visitors must log in to purchase or download.

---

2. When the download is complete, unzip the file to your hard drive, double-click to launch the ZMOTIONL200ZCOG\_<version>.exe installation file, and follow the on-screen instructions.

---

► **Note:** <version> represents the release version of the ZMOTIONL200ZCOG installation.

---

3. When the installation is complete, the ZMOTION documentation will be located in the following path, by default:

```
C:\Program Files\Zilog\ZMOTIONL200ZCOG_<version>\ZMOTION  
Lighting Documentation
```

### Documentation

The following documentation supports the ZMOTION 20-Pin Detection and Control Development Kit.

- ZMOTION Detection and Control Product Brief ([PB0225](#))
- ZMOTION Detection and Control Development Kit Quick Start Guide ([QS0076](#))
- ZMOTION Detection and Control Product Specification ([PS0285](#))
- This ZMOTION 20-Pin Detection and Control Development Kit User Manual ([UM0239](#))

The following documentation supports the ZMOTION Product Family.

- ZMOTION Detection Module:
  - ZMOTION Detection Module Product Brief ([PB0223](#))
  - ZMOTION Detection Module Product Specification ([PS0284](#))
- ZMOTION Intrusion Detection:
  - ZMOTION Intrusion Detection Product Brief ([PB0230](#))
  - ZMOTION Intrusion Detection Product Specification ([PS0288](#))
- Supporting Documentation:
  - ZMOTION Lens and Pyroelectric Sensor Product Specification ([PS0286](#))
  - ZMOTION – A New PIR Motion Detection Architecture White Paper ([WP0017](#))
  - ZMOTION Detection Lens and Pyro Sensor Configuration Guide ([WP0018](#))
  - Power Management and Customer Sensing with Zilog’s ZMOTION Detection Module ([AN0301](#))
  - ZMOTION Detection Module Application Walkthrough ([AN0307](#))
  - High Brightness LED Reference Design ([AN0309](#))
  - Controlling Power with the ZMOTION Detection Module and Clare Solid State Relays Application Note ([AN0319](#))
  - ZMOTION Intrusion Reference Design ([RD0001](#))
  - Motion Sensing & LED Control with a ZMOTION/ IXYS Display ([RD0003](#))
  - ZMOTION Detection Module II Reference Design ([RD0026](#))



---

## Safeguards

The following precaution must be observed when working with the devices described in this document.



**Caution:** Always use a grounding strap to prevent damage resulting from electrostatic discharge (ESD).

---

---

# ZMOTION 20-Pin Detection and Control Development Board

Zilog's ZMOTION 20-Pin Detection and Control Development Board is a development and prototyping platform for the ZMOTION 20-pin silicon and software, as well as for its lens/pyroelectric sensor/silicon and software bundled solutions. The Board provides the user with a tool to evaluate the many features of ZMOTION PIR technology as well as the actual performance of each lens and pyro combination.

## Features

The ZMOTION 20-Pin Detection and Control Development Board features the following elements:

- Z8FS040 ZMOTION 20-Pin Detection and Control MCU (20-pin SSOP)
- Mini-USB power connector and serial interface
- Power-On and Detection LED
- On-chip debugger interface
- Board openings for an assortment of lens holders and clip-on lens attachments
- Prototyping area
- 2.7V–3.6V operating voltage with 5V-tolerant inputs

## MCU Features

The Z8FS040 ZMOTION 20-Pin Detection and Control MCU combines the programmability and rich peripheral set of Zilog's Flash Z8 Encore! XP Family of MCUs with built-in motion detection software algorithms to provide the functions necessary for PIR motion detection applications.

The Z8FS040 MCU includes the following features:

- High-performance eZ8® MCU core
- 4KB in-circuit programmable Flash memory available for application code
- Single-pin debug with unlimited breakpoints
- Flexible clocking scheme
- Internal precision oscillator running at 5.53MHz
- External oscillator operating up to 20MHz
- Sigma Delta ADC
- Four single-ended channels or two differential channels available
- On-chip analog comparator with independent programmable reference voltage

- Full-duplex UART with dedicated BRG
- Two 16-bit timers with input capture, output compare and PWM capability (11 modes total)
- Watchdog timer (WDT) with dedicated internal oscillator
- Up to 20 vectored interrupts
- 16 I/O pins
- 2.7 V to 3.6 V operating voltage with extended operating temperature range  $-40^{\circ}\text{C}$  to  $+105^{\circ}\text{C}$
- Zilog PIR technology controlled and monitored via software API registers
- Selection capability from an assortment of lenses and pyroelectric sensors to best fit your application
- API settings provided for each lens and pyroelectric sensor combination
- Directly supports 1 or 2 pyroelectric sensors
- Sensitivity control, range control and directionality detection
- Extended detection modes for occupancy sensing
- Low power modes

## ZMOTION 20-Pin Detection and Control Development Kit Lenses and Pyroelectric Sensors

The ZMOTION 20-Pin Detection and Control Development Kit includes nine different types of lenses and three different types of pyroelectric sensors to fill a wide variety of lighting control, occupancy sensing, HVAC, display, proximity and power management applications. These applications also demonstrate the flexibility, and superior performance of Zilog's PIR motion detection technology.

Please refer to the [ZMOTION Lens and Pyroelectric Sensor Product Specification \(PS0286\)](#) for part-specific details about the individual lenses and pyroelectric sensors. Refer to the [ZMOTION 20-Pin Detection and Control Development Kit Quick Start Guide \(QS0085\)](#) for specific installation instructions for the lenses and pyroelectric sensors.

### Pyroelectric Sensor Options

The ZMOTION 20-Pin Detection and Control Development Kit includes the following three pyroelectric sensors:

- RE200B-P: a basic dual element sensor installed on the board
- SDA02-54-P, a premium dual-element sensor
- SBDI46-504AA, a quad-element sensor

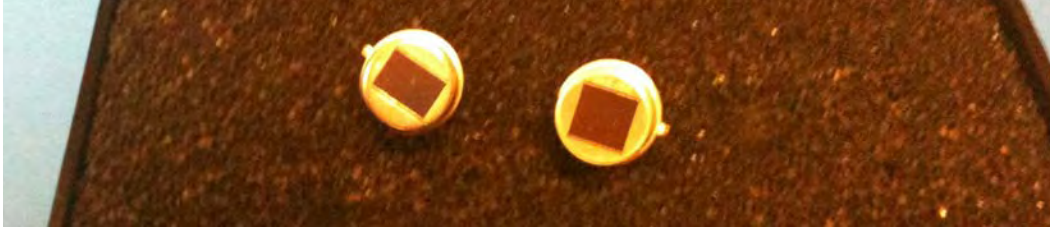

Figure 2. Two Additional Pyroelectric Sensors (L–R): SDA02-54-P and SBDI46-504AA

- **Note:** The type of sensor you use depends on your application requirements; however, not all sensors are suitable for all lenses.

## Lens Mounting Options

The ZMOTION 20-Pin Detection and Control Development Board supports four lens-mounting options, as indicated in Table 1. For lens installation instructions, please refer to the sections that follow.

**Table 1. Four Supported Lens-Mounting Options**

Lens Mounting	Supported Lens
PIR Sensor Clip-On	NCL-9(26)
	NCL-3B
	NCL-3R
	NCL-10S
	NCL-10IL
Circuit Board Clip-In	CWM 0.5 GI V1
Circular Lens Holder 0.77 Focal	CM 0.77 GI V3
	CM 0.77 GI V5
Flat Lens Holder 0.9 Focal	AA 0.9 GI T1

## Attaching the PIR Sensor Lens

Each of the clip-on lenses slide atop the PIR sensor, and the notch on the PIR sensor aligns with the notch in the base of the lens, as shown in Figure 3.



Figure 3. NCL-9(26) Lens and PIR Sensor Installed on the ZMOTION 20-Pin Development Board

## Attaching the Circuit Board Lens

This clip-in lens style clips directly into the circuit board over the top of the PIR sensor. There are 4 mounting clips on the lens that are aligned with the slots in the circuit board. Note the locating tab on the side of the lens is to be aligned with the silkscreened tab, as indicated in Figure 4.

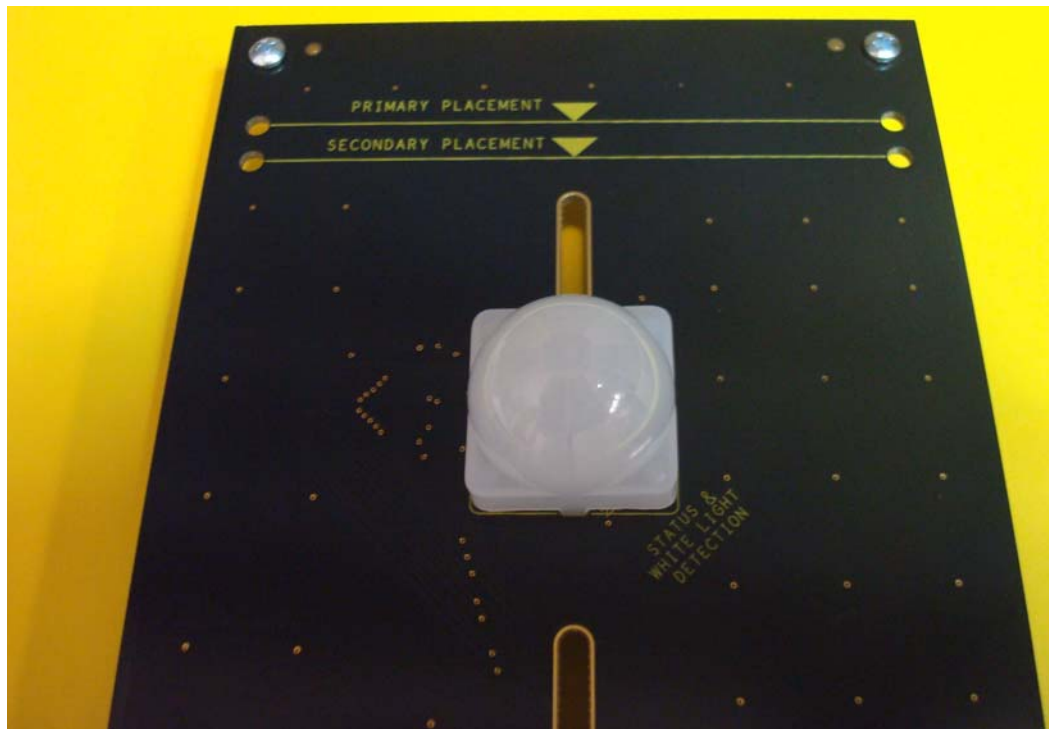

Figure 4. Assembled Clip-In Lens Installed on the ZMOTION 20-Pin Development Board

## Assembling the Circular Lens Holder

The circular lens holder, shown in Figure 5, is a 2-piece assembly that provides a 0.77" focal length mounting.



**Figure 5. Circular 0.77" Lens Holder (Cap and Base)**

To assemble the lens and lens holder, observe the following brief procedure.

1. Place the circular lens into the base of the lens holder, aligning the notch on the lens with the inside notch on the base.
2. Place the circular cap over the lens and the base ensuring the outside tab on the cap aligns with the outside tab on the base. Use the provided  $\frac{3}{4}$ " machine screws (2) with a nut to secure the cap in place.
3. Place the lens and lens holder assembly onto the ZMOTION 20-Pin Development Board by aligning the screw holes on the lens holder with the upper set of holes on the circuit board, as shown in Figure 6. The 4 screw holes in the circuit board should line up with the four center-mounting holes in the lens holder.



**Figure 6. Top of Lens Holder on the ZMOTION 20-Pin Development Board**

4. Use the provided  $\frac{3}{8}$ " machine screws (4) with a nut to secure the lens holder in place. See Figure 7.





**Figure 7. Assembled Circular 0.77" Lens Holder and Circular Lens Installed on the ZMOTION 20-Pin Development Board**

## Assembling the Flat Lens Holder

The flat lens holder, shown in Figures 8 and 9, is a two-piece assembly that provides a 0.9" focal length mounting.



Figure 8. Flat 0.9" Lens Holder (Cap and Base)

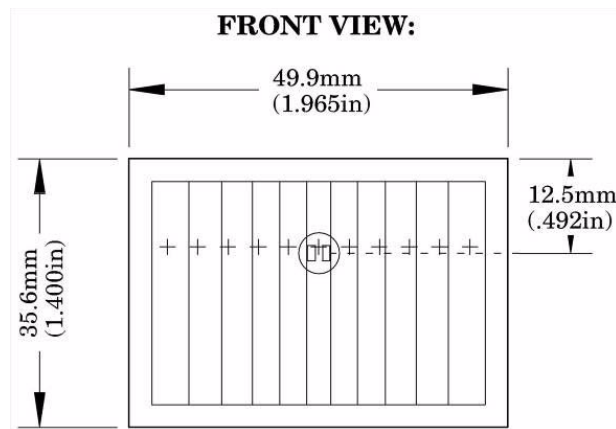

Figure 9. Flat Lens: AA 0.9 GI T1

To assemble this flat lens and holder, observe the following brief procedure.

1. Place the lens into the inside of the cap, ensuring that the grooves of the lens are facing inward.
2. Place the cap over the base, ensuring that the top of the lens is toward the arrow on the base. Use the provided 1/2" machine screws (2) with a nut to secure the cap in place; see the example in Figure 10.
3. Place the lens and lens holder assembly onto the ZMOTION 20-Pin Development Board with the arrow on the lens holder aligned with the primary placement arrow on the circuit board, as shown in Figure 10. The four screw holes in the circuit board should line up with the four upper mounting holes in the lens holder.

4. Use the provided  $\frac{3}{8}$ " machine screws (4) with a nut to secure the lens holder in place; see the example in [Figure 6](#) on page 12.

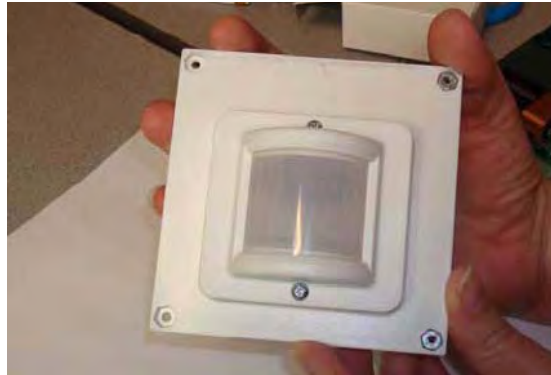

Figure 10. Assembled Flat 0.9" Lens Holder and Flat Lens

## Connecting the USB SmartCable

Observe the following steps to connect the USB SmartCable to the ZMOTION 20-Pin Development Board.



**Caution:** The power to the development board must be disconnected or turned OFF before connecting or disconnecting the USB SmartCable.

1. Attach one end of the six-conductor ribbon cable (included) to the USB SmartCable six-pin DBG connector, as shown in Figure 11.



Figure 11. Connecting the Six-Conductor Ribbon Cable to the USB SmartCable

2. Attach the free end of the ribbon cable to the DBG connector (ZDI Interface) on the development board. Ensure that pin 1 on the ribbon cable (indicated by the dark stripe) is aligned with pin 1 on the target connector (indicated by a 1 on P2 of the board).
3. Install the FTDI USB-to-serial driver. For assistance, see [Appendix B. Installing the FTDI USB-to-UART Driver](#) on page 26.

## Running the Sample Project

In this example, we reference the ZMOTION\_Serial\_Config project, which is the project that the kit is initially programmed with. The steps that follow show you how to build the project and run it on the ZMOTION Module in a debug session; these steps also apply to any of the other projects provided in the kit.

---

► **Note:** At this point, you should have installed the FTDI-to-USB Serial Driver and loaded ZDSII and the USB SmartCable driver onto your computer. If you haven't yet done so, refer to [Appendix A. Installing the USB SmartCable Driver](#) on page 23 and/or [Appendix B. Installing the FTDI USB-to-UART Driver](#) on page 26 to learn more about how to install these items.

---

1. Open ZDSII and select **File** → **Open Project**, then navigate via the following path to the project folder labeled ZMOTION\_Serial\_Config:  

```
C:\Program Files\Zilog\ZMOTIONL200ZCOG_<version>\SW Project and Downloads\ZMOTION_Serial_Config
```
2. Open the ZMotion\_Serial\_Config\_20\_Pin.zdsproj project. When you first receive your kit, this project is already loaded into the ZMOTION MCU. Right-click within the open grey area below the menu icons and select **Workbook Mode** to turn on the tabs at the bottom of the editor and therefore make it easier to switch between files.
3. Click the **Rebuild All** icon to build the project. The build output should not indicate any errors. If you receive errors, try reloading the projects from the original Application CD and ensure that the folders are not set to **Read Only**. See Figure 12 for an example; Figure 13 indicates the location of the **Rebuild All** icon in the ZDSII menu bar.

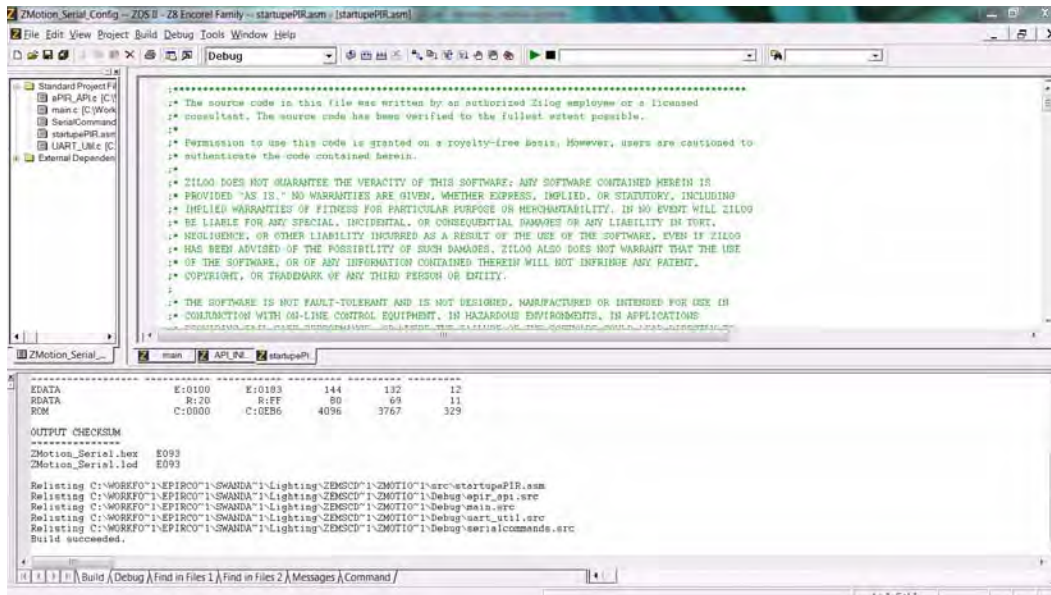

Figure 12. Building the ZMOTION\_Serial\_Config project in ZDSII

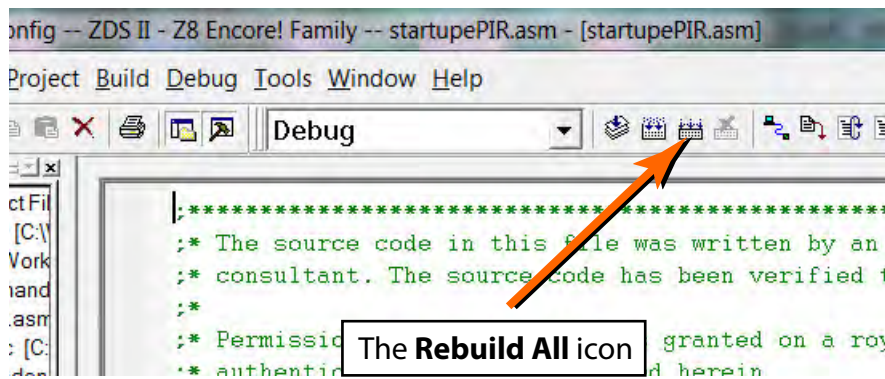

Figure 13. The Location of the Rebuild All Icon

4. Make sure that the ZMOTION 20-Pin Development Board is powered OFF, then connect the USB SmartCable (Debugger) to P2, as described above.
5. Ensure that the J8 jumper is closed in position 1–2, to control the USB power supply.
6. Apply power to the Development Board by plugging in the USB cable and setting SW1 to the ON position. Next, click the **Reset** icon in ZDSII. Figure 14 indicates the location of both the **Reset** and **Go** icons in the ZDSII menu bar.

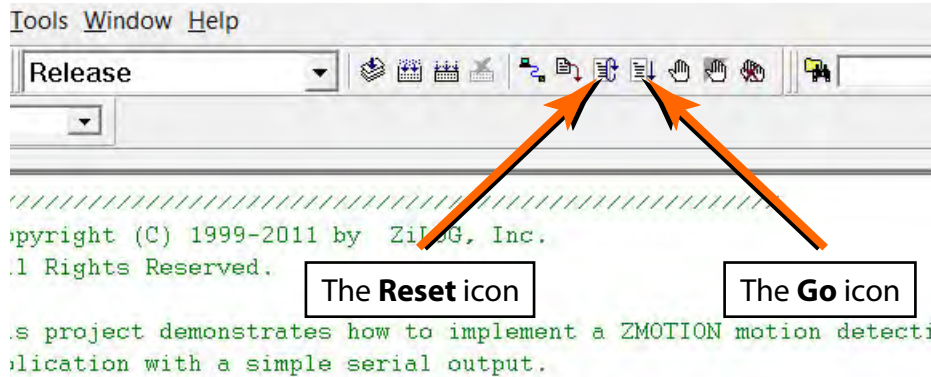

Figure 14. The Location of the Rest and Go Icons

- An information notice may appear, indicating that the silicon is not the latest version. This occurrence is normal and is not an issue. Click **OK** to continue. You should see a message in the Debug Output Window indicating that the load was successful, as shown in Figure 15.

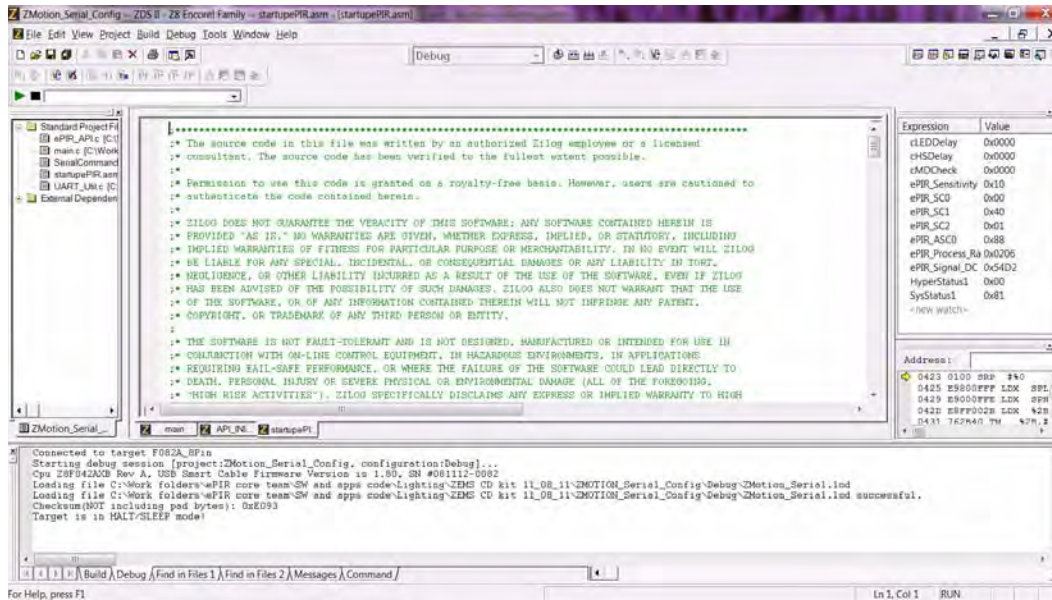

Figure 15. ZDSII's Debug Output Window for the ZMOTION\_Serial\_Config Project

- Click the **Go** icon to start the application running. The Red LED (LED3) will be ON initially until the pyroelectric sensor stabilizes – a period that can take up to 30 seconds. After it has stabilized, (LED3) turns OFF, to turn ON only when motion is detected.
- To test this procedure, wave your hand over the lens and notice (LED3) turning ON for approximately 1 second.

## ZMOTION 20-Pin Development Kit Application Software

The ZMOTION application software includes the ZMOTION\_Serial\_Config motion detection project, which is described in this section.

### ZMOTION\_Serial\_Config

The ZMOTION\_Serial\_Config project demonstrates the basic motion detection functionality of the ZMOTION 20-Pin Development Board. The MCU included with the Board is programmed with this project.

Each lens type is supported by an associated lens configuration header file which displays a name format of API\_INIT\_xx.h. Header files for all supported lens types are included in the include project folder of the ZMOTION\_Serial\_Config project. The main.c source file contains the include directive to add the header file to the project. Changes to these header files should not be required, but any modifications you make should be made to a copy of the original header file; *do not modify the original versions*. As new lens types are added to the ZMOTION family, an associated lens configuration file is made available on the Zilog website.

Table 2 lists additional project features that can be modified or enabled in main.c and main.h.

**Table 2. Additional Project Features**

Feature	File	Define/Variable	Default Values
LED ON time duration	main.h	DEF_LED_ON_TIME	DELAY_500MSEC (500 milliseconds)
Lens Support	main.c	#include "API_INIT_xx.h"	API_INIT_04.h

When motion is detected, the LED is turned ON for 500msec (DEF\_LED\_ON\_TIME). A serial terminal program such as HyperTerminal can be used to view the detection messages from the ZMOTION 20-Pin Development Board. In Figure 16, **26** indicates the version of the application; the **S** following the ZMOTION> prompt is displayed when the pyroelectric sensor has become stable and the system is ready to detect motion. When motion is detected, an **N** or **E** is displayed to indicate the type of detection (**N**ormal motion or **E**xtended motion), along with the count and a time stamp (in seconds) after power-up.

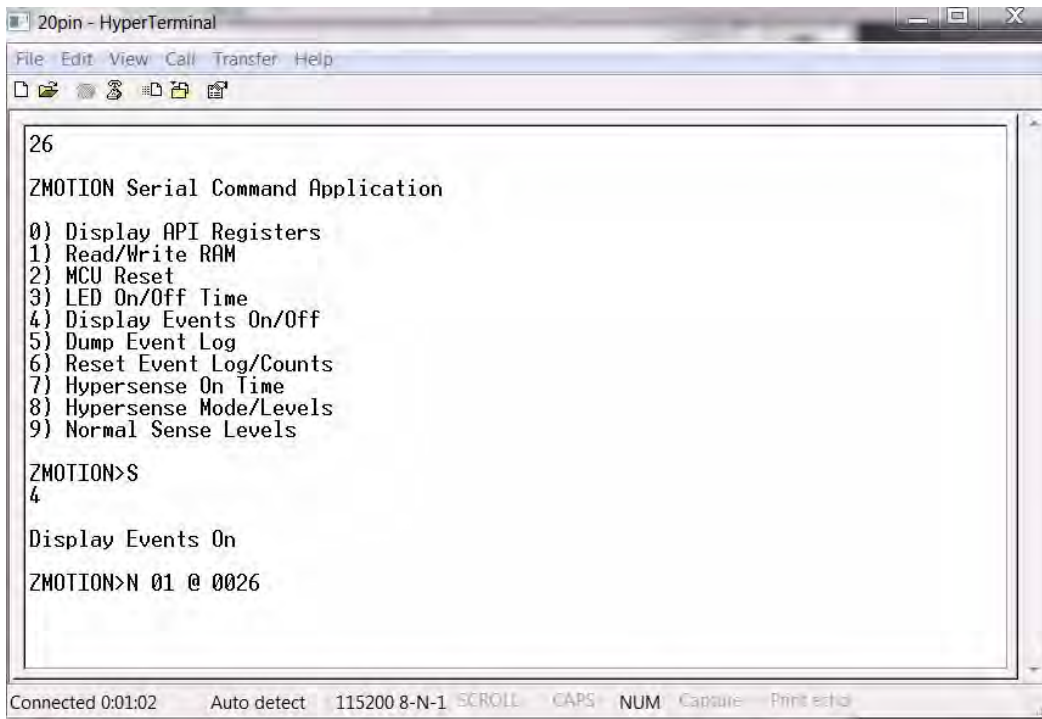

```
26
ZMOTION Serial Command Application
0) Display API Registers
1) Read/Write RAM
2) MCU Reset
3) LED On/Off Time
4) Display Events On/Off
5) Dump Event Log
6) Reset Event Log/Counts
7) Hypersense On Time
8) Hypersense Mode/Levels
9) Normal Sense Levels

ZMOTION>S
4
Display Events On
ZMOTION>N 01 @ 0026

Connected 0:01:02   Auto detect   115200 8-N-1  SCROLL  CAPS  NUM  Capture  Print echo
```

**Figure 16. The ZMOTION\_Serial\_Config Project Running in HyperTerminal**

The menu shown in Figure 16 allows you to monitor and make real-time changes to the operation of the motion detection software (a description of this menu's selections follows). When the ZMOTION device is reset or power-cycled, all settings return to their default values.

- 0) Display API Registers.** Displays the current setting of the ZMOTION Engine registers.
- 1) Read/Write RAM.** Allows you to make direct modifications to specific RAM locations (Peek/Poke).
- 2) MCU Reset.** Reset the ZMOTION MCU.
- 3) LED On/Off Time.** Sets the duration of the LED ON time and minimum LED OFF time.
- 4) Display Events On/Off.** Turns the automatic display of motion events ON or OFF. When OFF, events are still stored in the log.
- 5) Dump Event Log.** Displays a history of motion events since power-on.
- 6) Reset Event Log/Counts.** Clears the Event Log and resets the time stamp to 0.
- 7) Hypersense On Time.** If Hypersense mode (menu item 8) is enabled when motion is detected, the sensitivity of the system can be increased for a set amount of time; Hypersense On Time sets this time. If motion is detected while sensitivity is increased, the ON time starts over.



**8) Hypersense Mode/Level.** There are three settings that control sensitivity to motion during Hypersense; these settings are *Major Sensitivity*, *Minor Sensitivity* and *Range*. This menu option allows you to enable and set each of these settings individually.

**9) Normal Sense Level.** When in normal motion sense mode (i.e., not in Hypersense mode), this selection allows you to set the sensitivity levels of the three settings (*Major Sensitivity*, *Minor Sensitivity* and *Range*).

## Making Changes to the ZMOTION\_Serial\_Config Project

The operation of the motion detection software can be changed by making modifications directly to the source code. Follow the comments in the code (generally in `main.h` and `main.c`) to make any permanent changes. For example, to change the lens configuration file and the duration of the LED ON time, observe the following procedure.

1. Change the following line in the `main.h` file:

```
#define DEF_LED_ON_TIME DELAY_500MSEC           //Time the LED
                                                //stays on
                                                //when motion
                                                //is detected
```

2. Change the line as follows to select a five-second LED ON time:

```
#define DEF_LED_ON_TIME DELAY_5SEC             //Time the LED
                                                //stays on when
                                                //motion is
                                                //detected
```

---

► **Note:** LED ON time definitions are provided in the `main.h` file for values from 50ms to 30 minutes.

---

3. Click the **Rebuild** icon to build the project. The build output should not indicate any errors. Click the **Go** icon to download the modified project and start the application running. Generate motion and notice that the LED now stays on for 5 seconds.

```
// This file must match the lens and PIR sensor used in the application
//#include "API_INIT_00.h"           // Generic settings: non-lens-specific
//#include "API_INIT_01.h"           // API configuration file for AA 0.9 GI V1 Lens
//#include "API_INIT_02.h"           // API configuration file for CM 0.77 GI V3 Lens
//#include "API_INIT_03.h"           // API configuration file for CM 0.77 GI V5 Lens
#include "API_INIT_04.h"             // API configuration file for CWM 0.5 GI V1 Lens
//#include "API_INIT_05.h"           // API configuration file for NCL-9(26) Lens
//#include "API_INIT_06.h"           // API configuration file for NCL-10IL Lens
//#include "API_INIT_07.h"           // API configuration file for NCL-3B Lens
//#include "API_INIT_08.h"           // API configuration file for NCL-3R Lens
//#include "API_INIT_09.h"           // API configuration file for NCL-10S Lens
//#include "API_INIT_0A.h"           // API configuration file for NCL-11 Lens
//#include "API_INIT_IML-0643.h+"    // API configuration file for IML-0643 Lens
```

► **Note:** As the code listed above demonstrates, the `API_INIT` file must match the lens and pyroelectric sensor being used on the Development Board. Use the Lens Selection Guide in the [ZMOTION Lens and Pyroelectric Sensor Product Specification \(PS0286\)](#) to determine which `API_INT` file is required for each lens setting.

---

4. To change the lens used by the project, edit the `include` line at the top of the `main.c` file to include the appropriate `API_INIT` file. The project initially uses `API_INIT_04.h` to support the CWM 0.5 GI V1 (board clip-in) lens; see the above code example. To use a different lens, edit out the comment characters (`//`) in the `main.c` file that correspond to the new lens, and comment out the lens that is no longer in use.

---

# Appendix A. Installing the USB SmartCable Driver

The USB Smart Cable can be installed on PCs that run on Windows 7 (32- and 64-bit), Windows Vista (32- and 64-bit) and Windows XP operating systems. The procedures in this appendix will guide you through the USB Smart Cable installation process.

## Windows 7 32/64 Systems

Observe the following steps to install the USB Smart Cable on a Windows 7 system.

1. Connect the USB Smart Cable to a USB port on your development PC. When the PC detects the new hardware, it will display the Installing device driver software dialog.
2. Windows automatically searches for the driver; this process can take a few moments. Because there is no option to terminate this search process, wait for the search to complete.

If the driver was previously installed, Windows will automatically install the USB Smart Cable driver. If this is the case, skip ahead to [Step 9](#). If Windows cannot find the driver, close the search dialog and proceed to the next step.

3. From the Start menu, navigate via the **Search Programs and files** menu, and enter `Device Manager` in the **Search** field to cause the Device Manager to appear in a list of search results.
4. From this search list, click **Device Manager** to open the Device Manager dialog, which presents a list of devices that operate on your PC. Find **Other devices**, toggle it to view a sublist of additional devices, and right-click your mouse on **USB Smart Cable**.
5. In the submenu that appears, click **Update Driver Software...**
6. In the **Update Driver Software – USB Smart Cable** dialog that appears, click the **Browse my computer for driver Software** option.
7. Click the **Browse...** button to browse to one of the following driver directories, depending on the configuration of your PC.

On 32-bit Windows 7 systems, navigate to:

```
<ZDS II Installation Directory>\device drivers\USB\x32
```

On 64-bit Windows 7 systems, navigate to:

```
<ZDS II Installation Directory>\device drivers\USB\x64
```

8. Click **Next** to install the driver. On 32-bit: Windows systems, a security dialog will appear; select **Install this driver software anyway**.
9. Click **Close** after the Wizard finishes the installation.

---

## Windows Vista 32/64 Systems

Observe the following steps to install the USB Smart Cable on a Windows Vista system.

1. Connect the USB Smart Cable to a USB port on the development PC.
2. After the PC detects the new hardware, it will display the Found New Hardware Wizard dialog box. Click **Locate and install driver software (recommended)**.
3. Depending on your development PC's User Account Control settings, Windows may ask for permission to continue the installation. Click **Continue**.
4. When the Insert the Disc dialog appears, select **I don't have the disc. Show me other options**. Click the **Next** button to display the Windows couldn't find driver dialog.
5. Select **Browse my computer for driver software (advanced)** to display the Browse For Driver dialog, which prompts you to key in or browse for the location of the driver's .inf file. Depending on the type of computer you use (32-bit or 64-bit), use the **Browse...** button to navigate to one of the following paths, then click the **Next** button.

On 32-bit Vista systems, navigate to:

```
<ZDSII Installation>\device drivers\USB\x32
```

On 64-bit Vista systems, navigate to:

```
<ZDSII Installation>\device drivers\USB\x64
```

6. When the Windows Security dialog prompts you whether to install or not install, click **Install this driver software anyway** and wait until the installation is completed (Windows may prompt you more than once).
7. When the software has been installed successfully, click **Close**.

## Windows XP Systems

Observe the following steps to install the USB Smart Cable on a Windows XP system.

1. Connect the USB Smart Cable to a USB port on the development PC. When the PC detects the new hardware, it will display the Found New Hardware Wizard dialog.
2. In the Wizard, select **Install from a list or specific location (Advanced)**, then click **Next**.

---

► **Note:** If the Windows Hardware Installation dialog appears, click **Continue Anyway**.

---

3. In the Please choose your search and installations dialog, select **Search for the best driver in these locations and include this location in search**.
4. Use the **Browse...** button to navigate to one of the following paths:

<ZDSII Installation>\device drivers\USB\x32

5. Click **Next** to locate the appropriate driver.
6. Click **Next**, then click **Finish** to complete the installation.

---

## Appendix B. Installing the FTDI USB-to-UART Driver

An FTDI USB-to-UART driver is required to allow your PC to communicate through its USB port to the on-chip UART of the Z8F042A MCU. Observe the following procedure to perform these connections.

1. Ensure that the USB cable is not plugged in to the Buck Converter Battery Charger Design Module's USB J1 connector.
2. Navigate to the following filepath and double-click the CDM20802\_setup.exe file to begin the driver installation.

```
<ZDS II Installation>\device drivers\FTDI Uart
```

3. The installation process will begin and you should observe output similar to the following messages on the screen of your PC:

```
32-bit OS detected  
<installation path>\dpinstx86.exe  
Installation driver  
FTDI CDM driver installation process completed...
```

4. When the installation is complete, plug in the B connector of the USB cable into the Board, and the larger A connector into the USB port of your PC.
5. If the driver installation was successful, the Ports (COM & LPT) section of the Device Manager will display USB Serial Port (COMx) or similar message, as highlighted in Figure 2.



**Figure 17. A Successful USB-to-UART Driver Installation**

- 
- **Note:** To launch the Device Manager on Windows 7 systems, launch the **Start** menu, enter device manager in the **Search programs and files** field, and press the Enter key.

To open the Device manager on earlier Windows systems, navigate via the following path:

**Start** → **Control Panel** → **System** → **Hardware** → **Device Manager** → **Ports (COM& LPT)**.

---

# Appendix C. Schematic Diagrams

Figures 18 and 19 show the schematics for the ZMOTION 20-Pin Development Board.

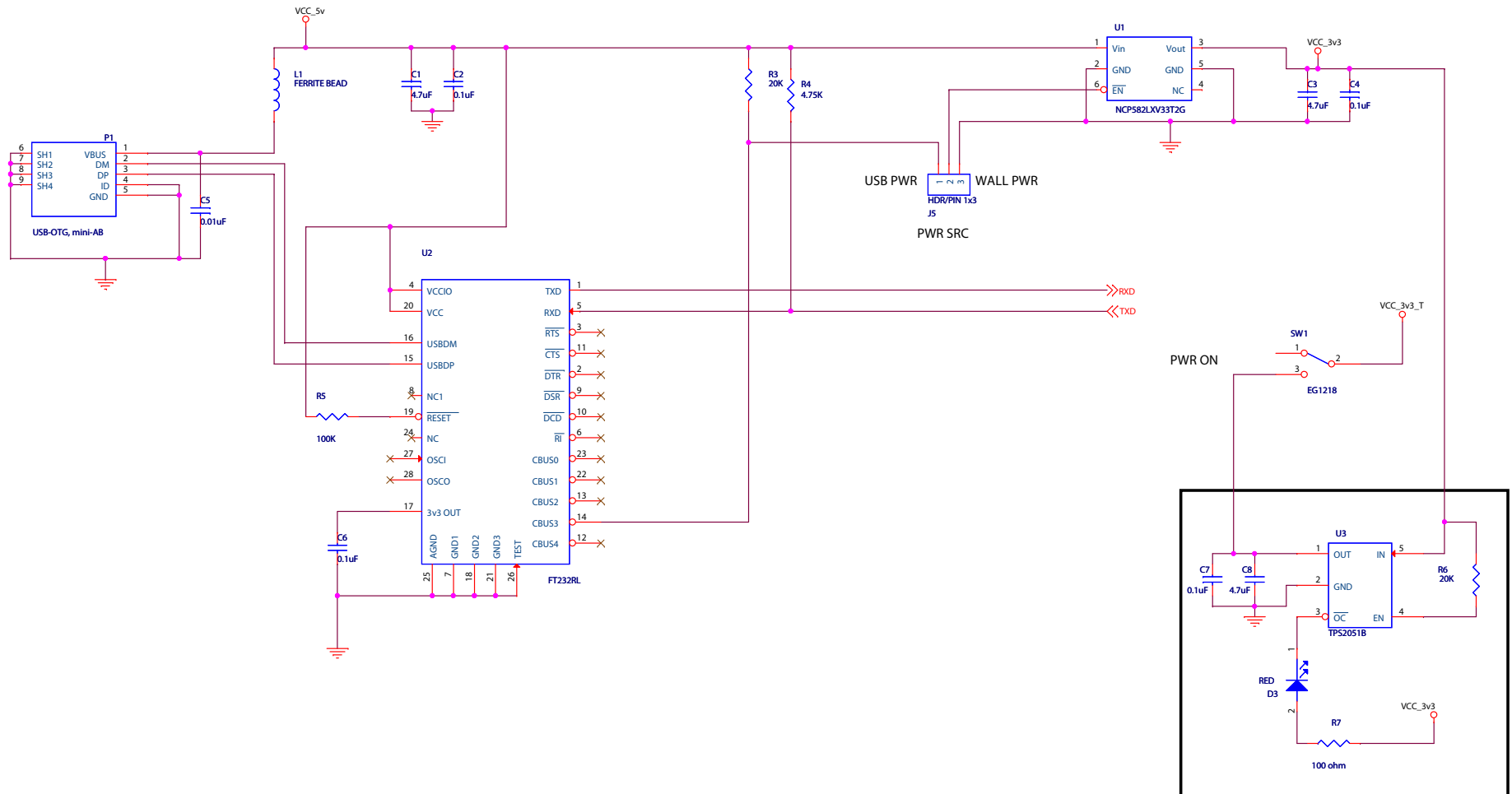

Figure 18. ZMOTION 20-Pin Development Board Schematic Diagram, #1 of 2



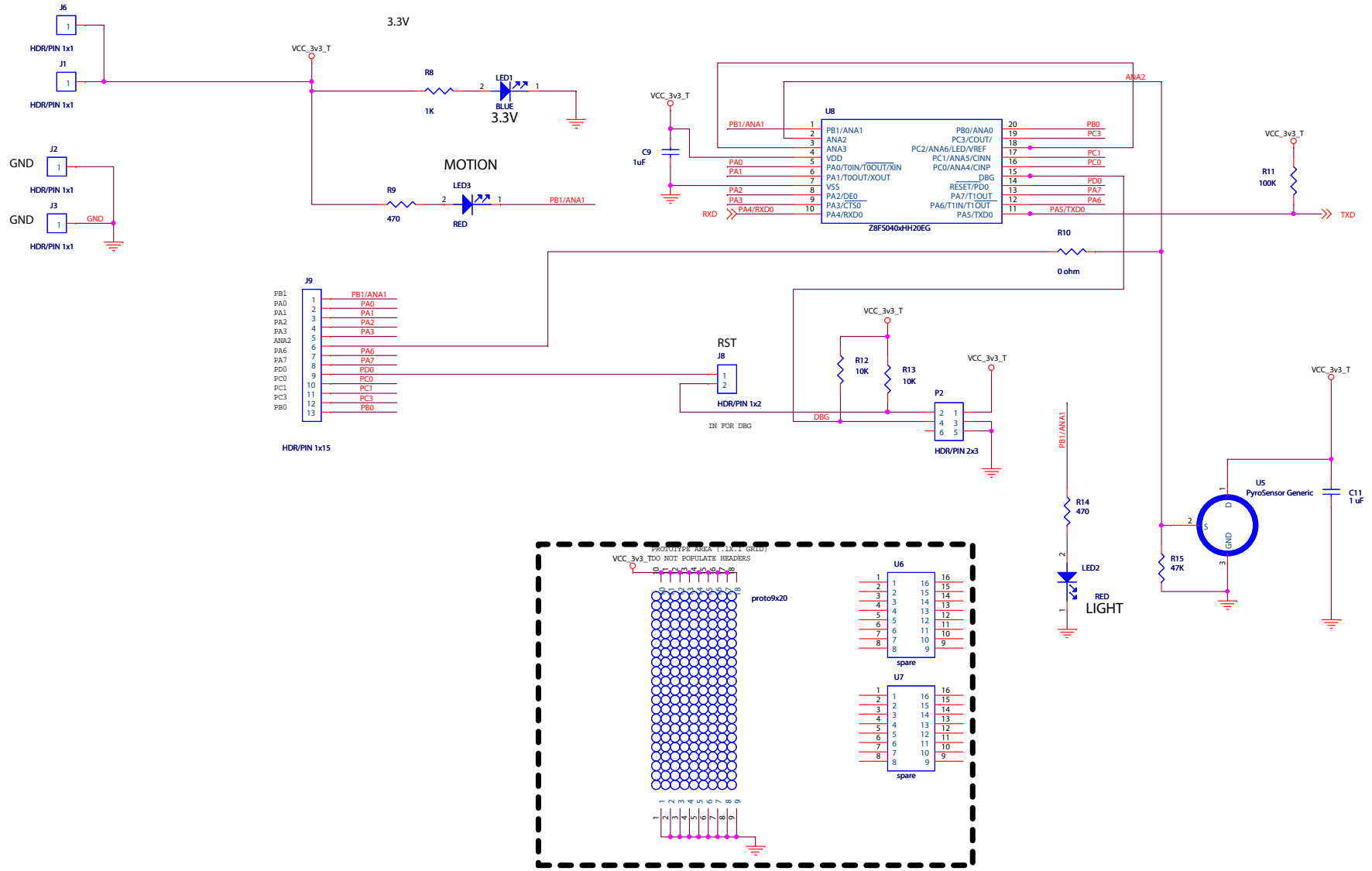

Figure 19. ZMOTION 20-Pin Development Board Schematic Diagram, #2 of 2

---

# Customer Support

To share comments, get your technical questions answered, or report issues you may be experiencing with our products, please visit Zilog's Technical Support page at <http://support.zilog.com>.

To learn more about this product, find additional documentation, or to discover other facts about Zilog product offerings, please visit the [Zilog Knowledge Base](#) or consider participating in the [Zilog Forum](#).

This publication is subject to replacement by a later edition. To determine whether a later edition exists, please visit the Zilog website at <http://www.zilog.com>.