

THIS DRAWING IS UNPUBLISHED. RELEASED FOR PUBLICATION ,19 .
 © COPYRIGHT 19 BY AMP INCORPORATED. ALL INTERNATIONAL RIGHTS RESERVED.

LOC	DIST	P	F	ZONE	LTR	DESCRIPTION	DATE	APPD
CH	11				A	ECN 92102701		
					B	EC 0B20-1551-98	20/NOV/98	RNP
					B1	REVISED PER ECO-09-020935	09SEP09	AEG

1. WIRE RACK MARKS PERMISSIBLE IN THREAD RELIEF AFTER PLATING.

△2 OBSOLETE PARTS: OBSOLETE CIS STREAMLINING PER D.RENAUD/D.SINISI

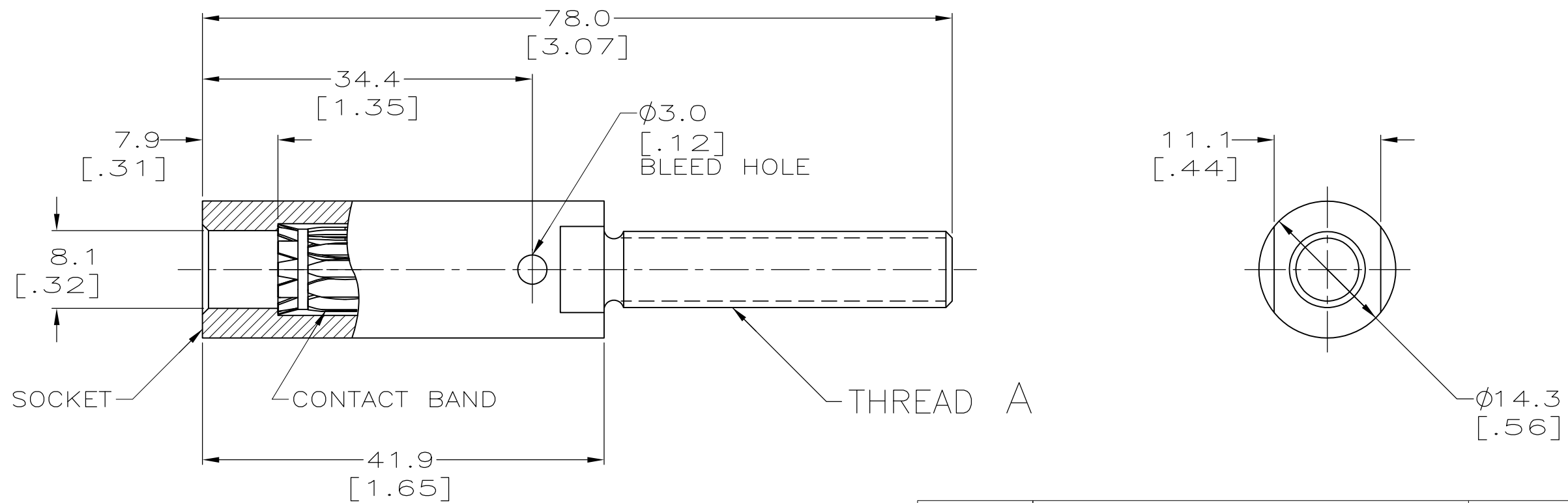

△2 OBSOLETE	M8 X 1.25-6g	192271-3
	5/16-24UNF-2A W/HARDWARE	192271-2
	5/16-24UNF-2A	192271-1

DO NOT SCALE PRINT. UNLESS SPECIFIED DIMENSIONS IN mm [INCHES] TOLERANCES ON:		DR D. WILSON 03-12-92		AMP AMP Incorporated Harrisburg, PA 17105-3608
1 PLC DEC ± 0.5 [.02] 2 PLC DEC ± 0.25 [.010] ANGLES ± -		CHK R. JAYNE 03-13-92		
MATERIAL	BRASS	APPD S. SIEGRIST 03-17-92	APPD P. GLASER 03-17-92	NAME
FINISH	SILVER PLATE 200-400µ THK	PRODUCT SPEC	-	SOCKET ASSY, 8mm
		APPLICATION SPEC	-	SIZE B
		WEIGHT	-	CAGE CODE 00779
				DRAWING NO 192271
				SCALE 2:1
				SHEET 1 OF 1