

25 WAY CONNECTOR ASSEMBLY
KEY 1 & KEY 5

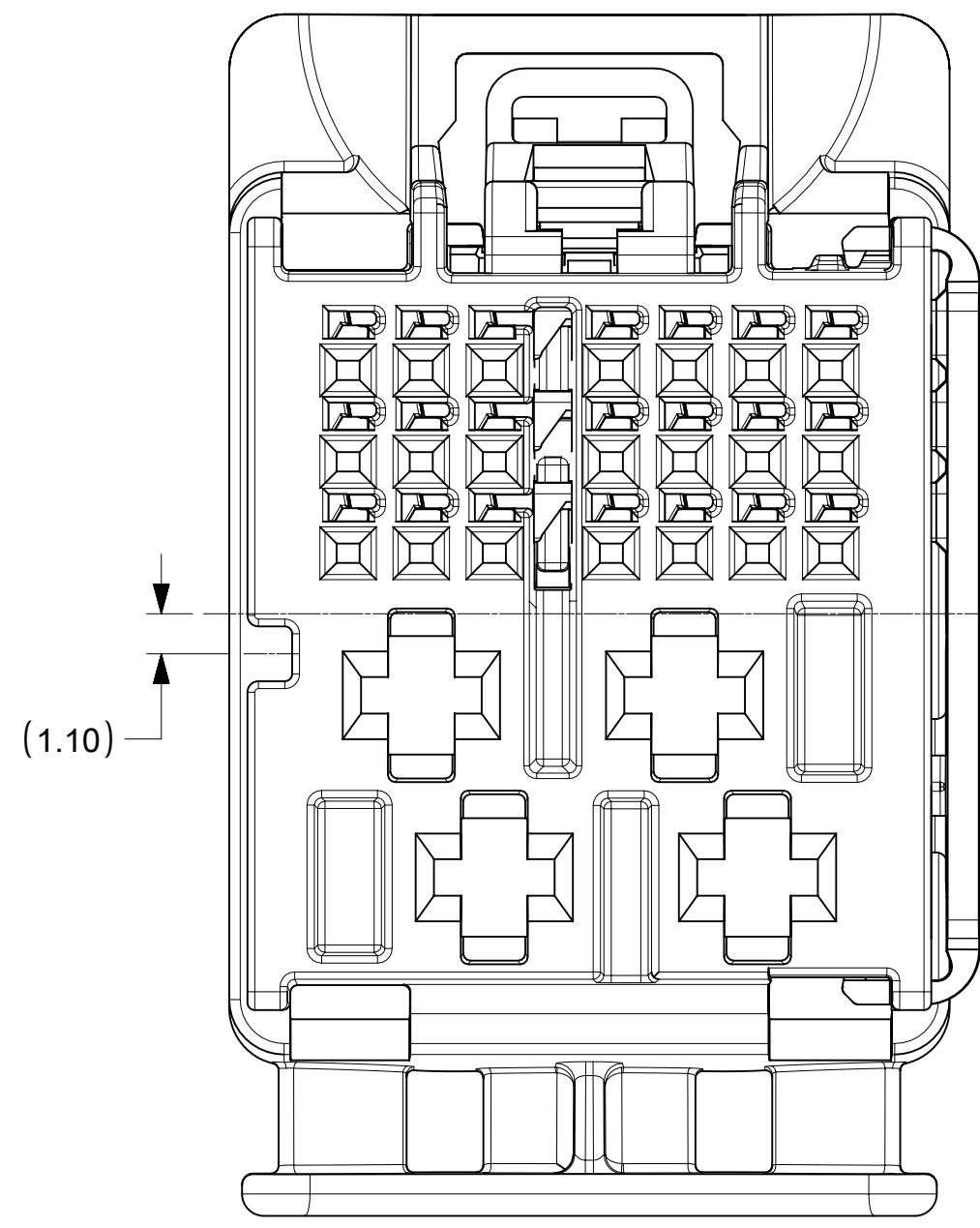

25 WAY CONNECTOR ASSEMBLY
KEY 2 & KEY 6

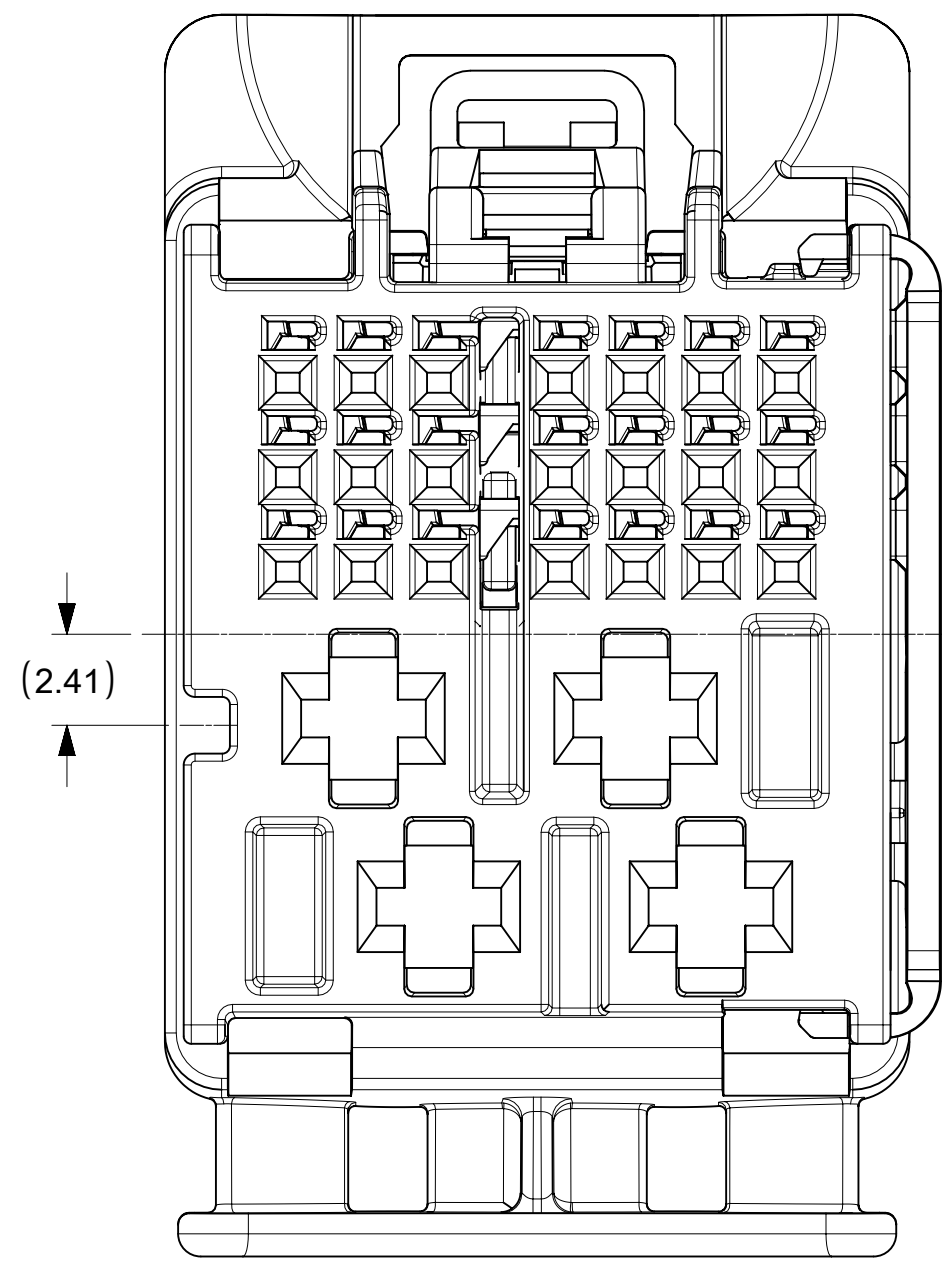

25 WAY CONNECTOR ASSEMBLY
KEY 3 & KEY 7

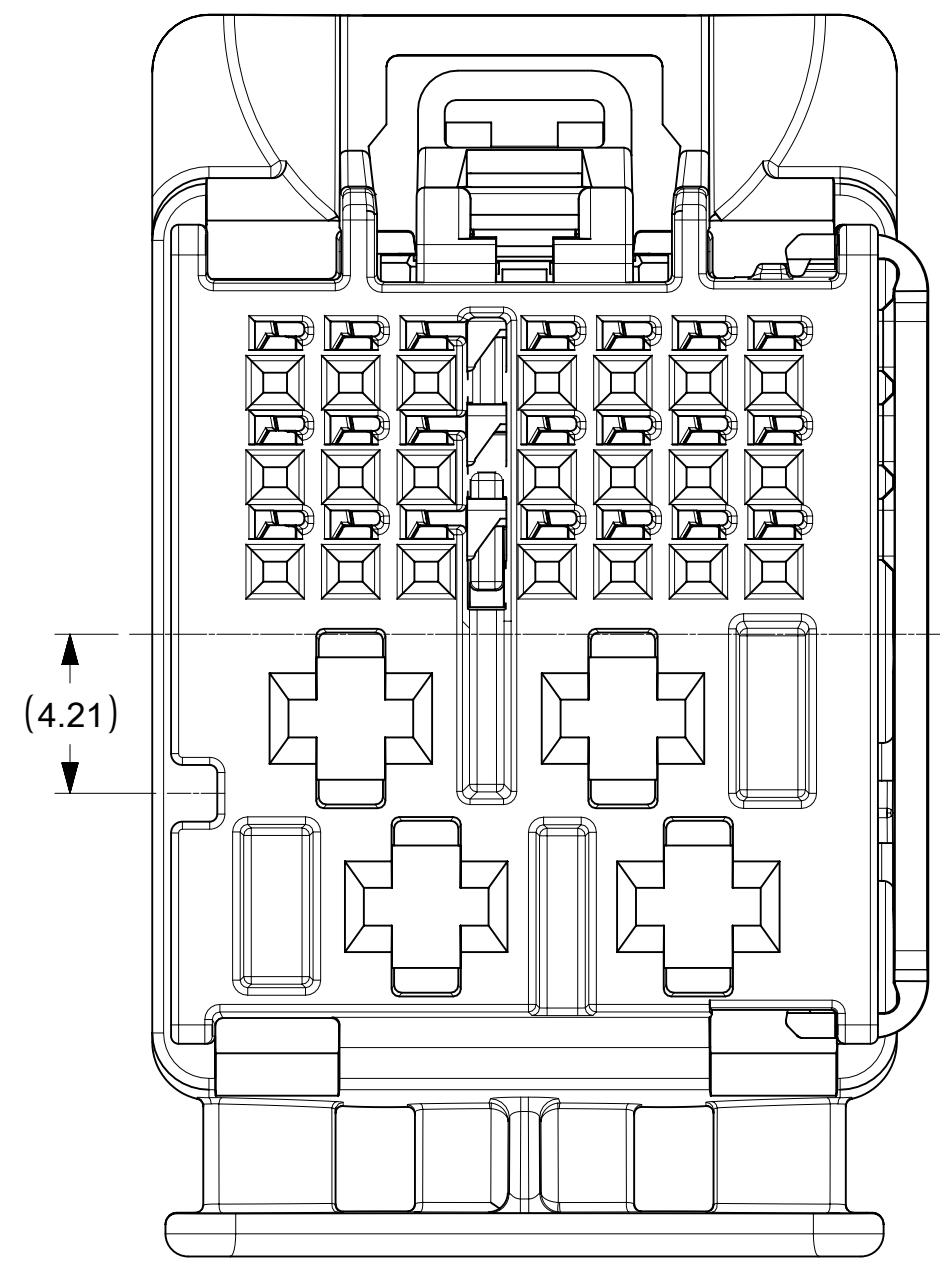

25 WAY CONNECTOR ASSEMBLY
KEY 4 & KEY 8

NOTES: VALID UNLESS OTHERWISE SPECIFIED

1. GENERAL:
- a. APPLICATION SPECIFICATION SEE: AS-160014-001
 - b. PRODUCT SPECIFICATION SEE: PS-160014-001
 - c. PACKAGING SPECIFICATION PER MOLEX DRAWING: PK-31302-266
 - d. PARTS MUST BE IN COMPLIANCE TO MOLEX CHEMICAL SUBSTANCES FOR PRODUCTS AND PACKAGING SPECIFICATION: ES-40000-5016
 - e. DATA MUST BE SUBMITTED UNDER THE MOLEX PART NUMBER TO IMDS (COMPANY ID#13255)

2. DESIGN - MATERIALS:
- a. SEE BOM TABLE

3. DESIGN - GEOMETRY:
- a. ALL GRAPHIC DATA IS BASIC (NO TOLERANCE) AND MUST BE TAKEN FROM THE DATA FILE AT ITS LATEST REVISION.
 - b. PRODUCT DESIGN MODEL NUMBER(S): SEE BOM TABLE
 - c. GEOMETRIC DIMENSIONS AND TOLERANCES PER ASME Y14.5-2009
 - d. EDGES AND UNDIMENSIONED DETAILS PER ISO13715
 - e. CORNERS SHOWN AS SHARP TO BE R 0.2 MAX.
 - f. MARKED TEXT TO INCLUDE RECYCLING CODE, CAVITY ID, VENDOR IDENTIFICATION AND CUSTOMER MATERIAL NUMBER.
 - 1. LASER ETCHED DATE CODE
 - 1ST THROUGH 2ND DIGIT = CALENDAR YEAR
 - 3RD THROUGH 5TH DIGIT = "DAY #" OF YEAR
 - 6TH THROUGH 7TH DIGIT = HOUR OF DAY
 - 8TH THROUGH 9TH DIGIT = MINUTE OF HOUR
 - 10TH THROUGH 11TH DIGIT = SECOND OF MINUTE

4. DESIGN - MANUFACTURING:
- a. VISUAL DEFECTS SHALL MEET COSMETIC STANDARD PS-45499-002 (Class B)

PART NUMBER	PLATING	SUPPLIER	WIRE GAGE (mm2)	TERMINAL FAMILY	WIRE SPECIFICATION
200096-3101	TIN PLATING	MOLEX	0.35	TAK FAMILY (0.5 mm)	VW 60306 OR GMW 15626 (SEE APPLICATION SPECIFICATION FOR MORE DETAILS)
200096-3201	TIN PLATING	MOLEX	0.13	TAK FAMILY (0.5 mm)	
2272196-2	TIN PLATING	TE	0.35	Generation 50 Locking Lance (0.5mm)	SAE/ J1128 THIN WALL INSULATION
2272196-1	TIN PLATING	TE	0.13	Generation 50 Locking Lance (0.5mm)	
1-968851-1	TIN PLATING	TE	1.0 - 2.5	AMP MCP 2.8	GMW 15626 INSULATION TYPE FLR (REGULAR THIN WALL)
1-968849-1	TIN PLATING	TE	0.5 - 1.0	AMP MCP 2.8	
15457849	TIN PLATING	DELPHI	1.5 - 2.5	CTS 2.8mm	
15457848	TIN PLATING	DELPHI	0.5 - 1.0	CTS 2.8mm	

ITEM	DESCRIPTION	COLOR	RECYCLING CODE	WEIGHT (GRAMS)	RIB OPTION	NO OF ITEMS REQUIRED														
1	OUTER SHROUD - KEY 1	LIGHT GREEN B	SPS/PA66-GF20	4.1	A	1														
2	OUTER SHROUD - KEY 2	STONE GRAY	SPS/PA66-GF20	4.1	A		1													
3	OUTER SHROUD - KEY 3	BLACK	SPS/PA66-GF20	4.1	A			1												
4	OUTER SHROUD - KEY 4	DARK GRAY	SPS/PA66-GF20	4.1	A				1											
5	OUTER SHROUD - KEY 5	DK PURPLE A	SPS/PA66-GF20	4.1	B					1										
6	OUTER SHROUD - KEY 6	TBD	SPS/PA66-GF20	4.1	B						1									
7	OUTER SHROUD - KEY 7	TBD	SPS/PA66-GF20	4.1	B							1								
8	OUTER SHROUD - KEY 8	LT GRAY	SPS/PA66-GF20	4.1	B								1							
9	ISL	NATURAL	SPS-GF30	0.37	N/A	1	1	1	1	1	1	1	1	1	1	1	1	1	1	1
10	CPA	NATURAL	PA66-GF50	0.08	N/A	1	1	1	1	1	1	1	1	1	1	1	1	1	1	1
11	INNER HOUSING	STONE GRAY	SPS/PA66-GF20	1.04	N/A	1	1	1	1											
12	INNER HOUSING	STONE GRAY	SPS/PA66-GF20	1.04	N/A							1	1	1	1	1	1	1	1	1

MOLEX ASSEMBLY PART NO.'S	
1600270011	KEY 1
1600270012	KEY 2
1600270013	KEY 3
1600270014	KEY 4
1600270015	KEY 5
1600270016	KEY 6
1600270017	KEY 7
1600270018	KEY 8

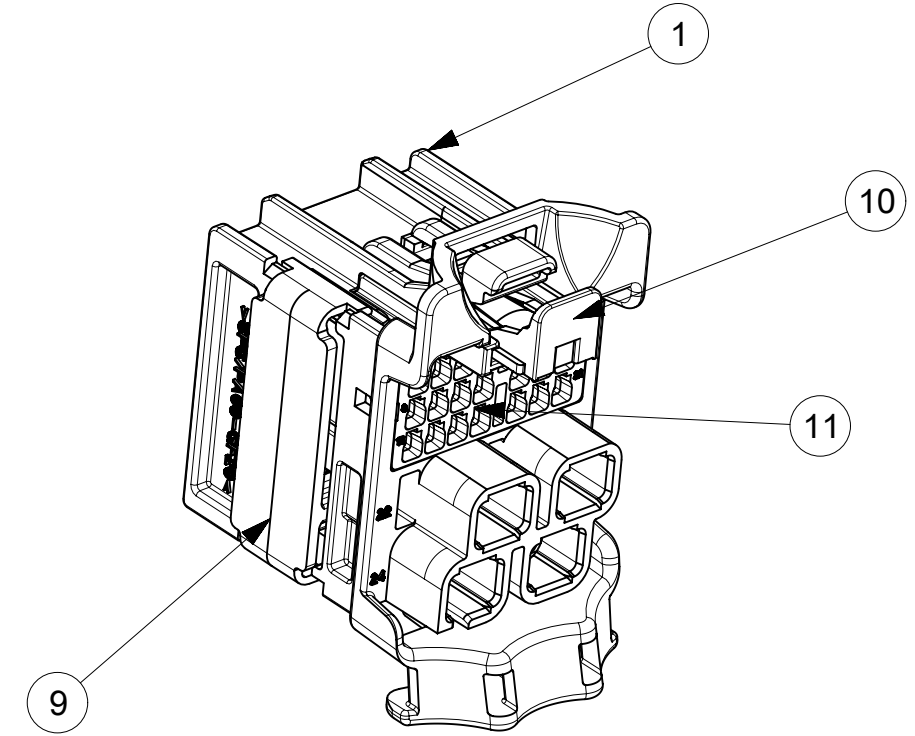

SCALE 2:1

RIB OPTION A

RIB OPTION B

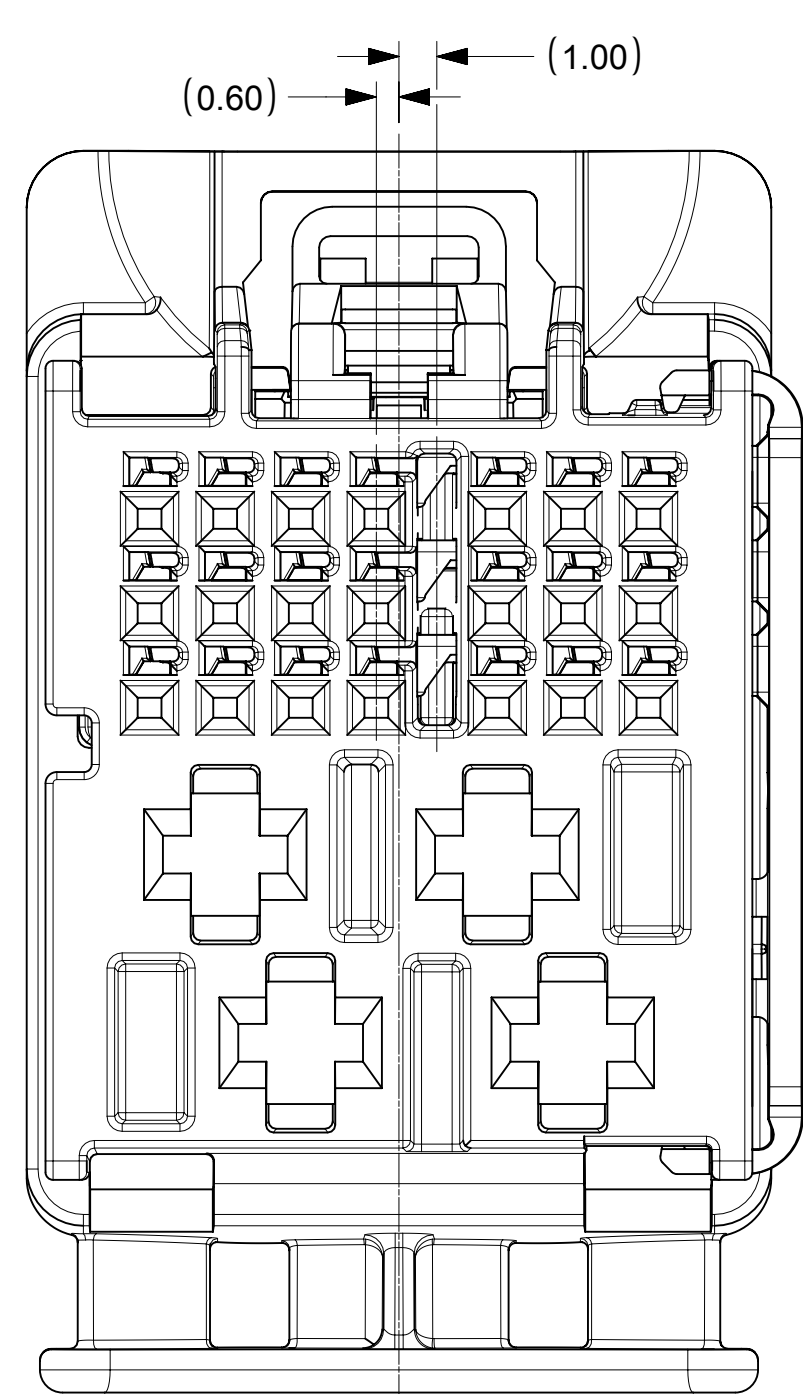
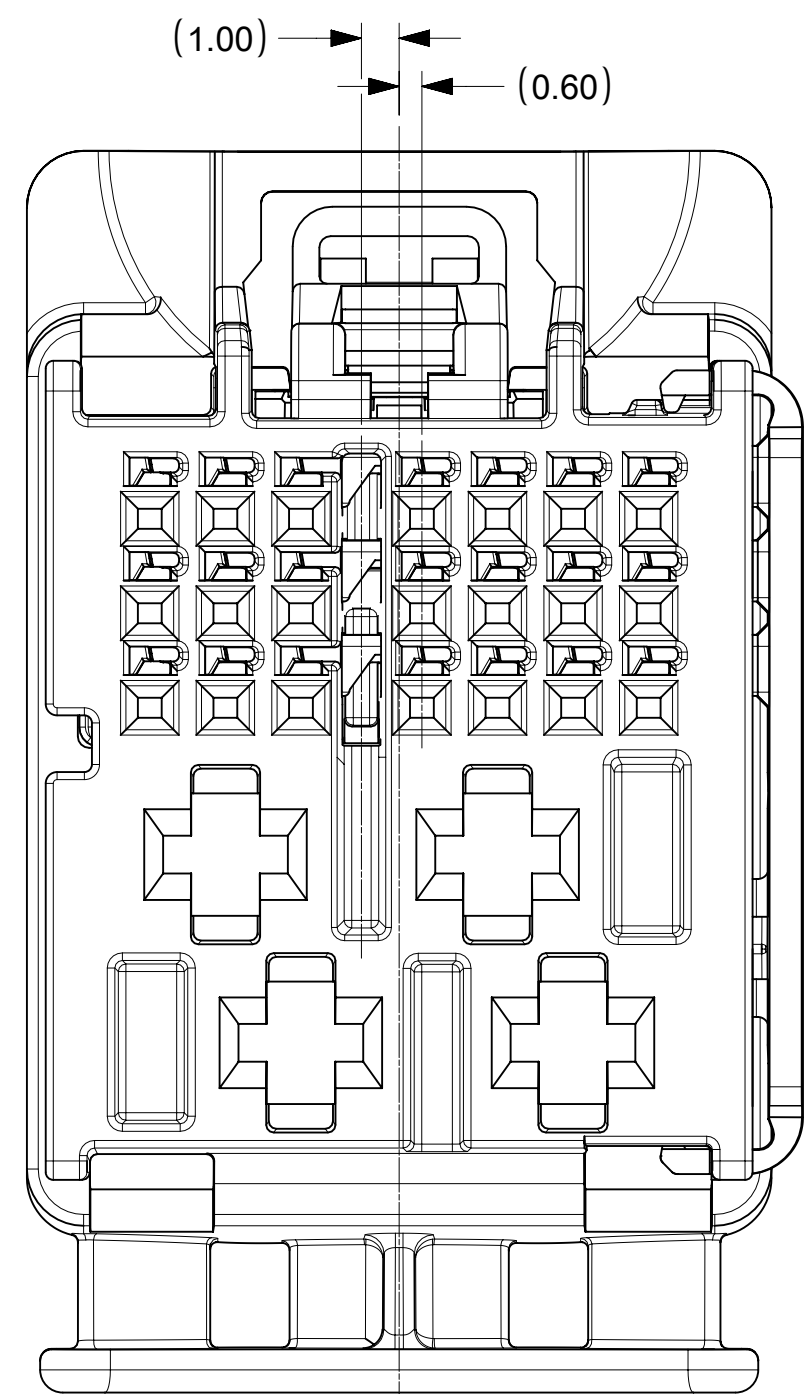

INSPECTION BALLOON NUMBER LOG	
PER DRAWING REVISION :	A3
LAST BALLOON NUMBER:	2
ADDED BALLOON NUMBER:	NONE
DELETED BALLOON NUMBER:	NONE

A4	UPDATED TAK50 TERMINAL PINS 21-July-2021 YPENG47 ECN 648438
REVISION	DESCRIPTION

SYMBOLS	THIS DRAWING CONTAINS INFORMATION THAT IS PROPRIETARY TO MOLEX ELECTRONIC TECHNOLOGIES, LLC AND SHOULD NOT BE USED WITHOUT WRITTEN PERMISSION		CURRENT REV DESC: UPDATED TAK50 TERMINAL PINS	
	DIMENSION UNITS	SCALE		
▽ = 0	mm	5:1		
▽ = 0	GENERAL TOLERANCES (UNLESS SPECIFIED)			
▽ = 0	ANGULAR TOL	± 3.0°		
▽ = 0	4 PLACES	±		
▽ = 0	3 PLACES	±		
▽ = 0	2 PLACES	± 0.3		
▽ = 0	1 PLACE	± 0.3		
▽ = 0	0 PLACES	± 0.3		
■ = 0	DRAFT WHERE APPLICABLE MUST REMAIN WITHIN DIMENSIONS			
▽ = 0	THIRD ANGLE PROJECTION	DRAWING	SERIES	
		D-SIZE	160027	
		MATERIAL NUMBER	CUSTOMER	SHEET NUMBER
		SEE CHART	GENERAL MARKET	1 OF 2

molex

25WAY STAK50H HYBRID ASSEMBLY
CONNECTOR ASSEMBLY

PRODUCT CUSTOMER DRAWING

DOCUMENT NUMBER	DOC TYPE	DOC PART	REVISION
1600270011	PSD	000	A3

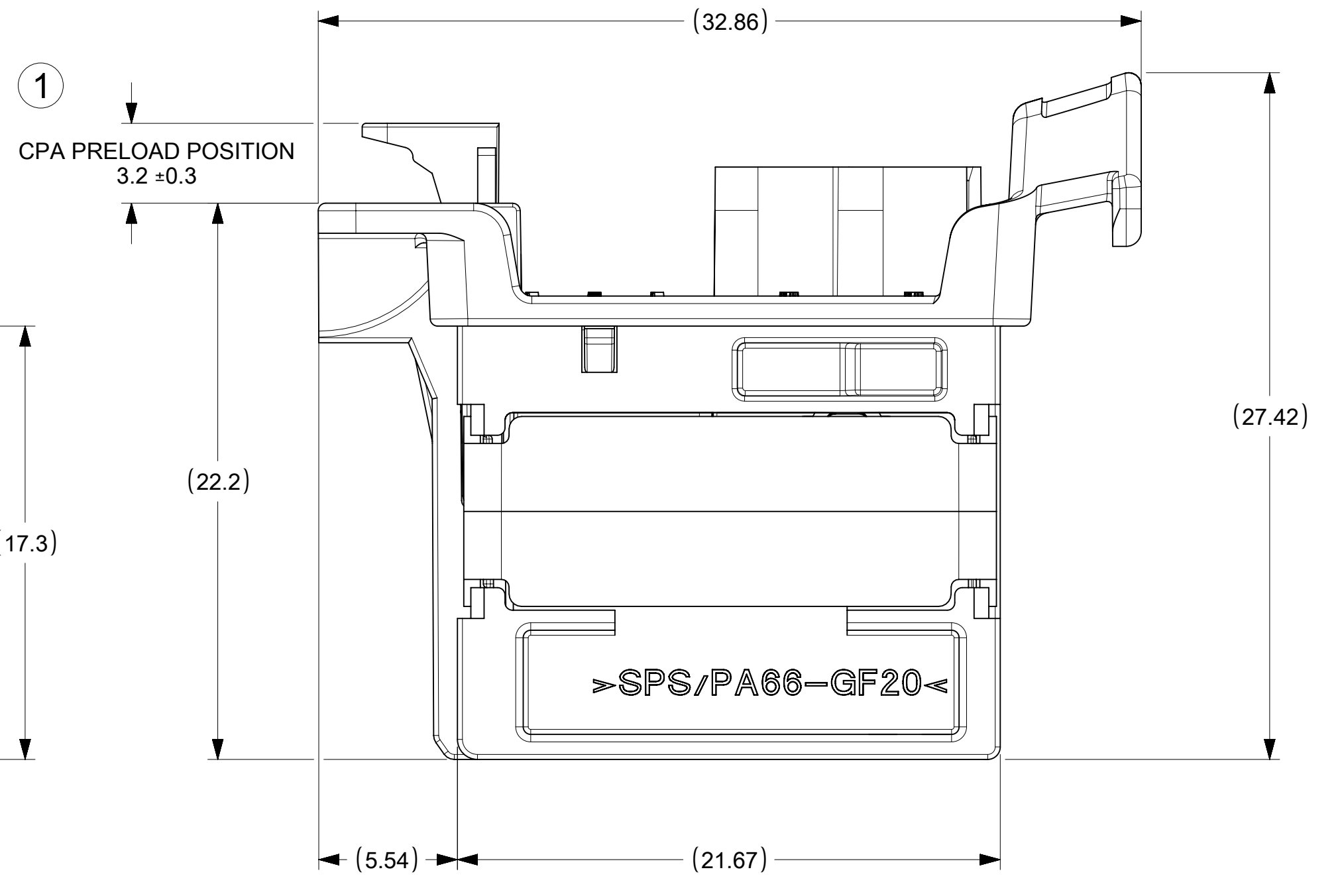
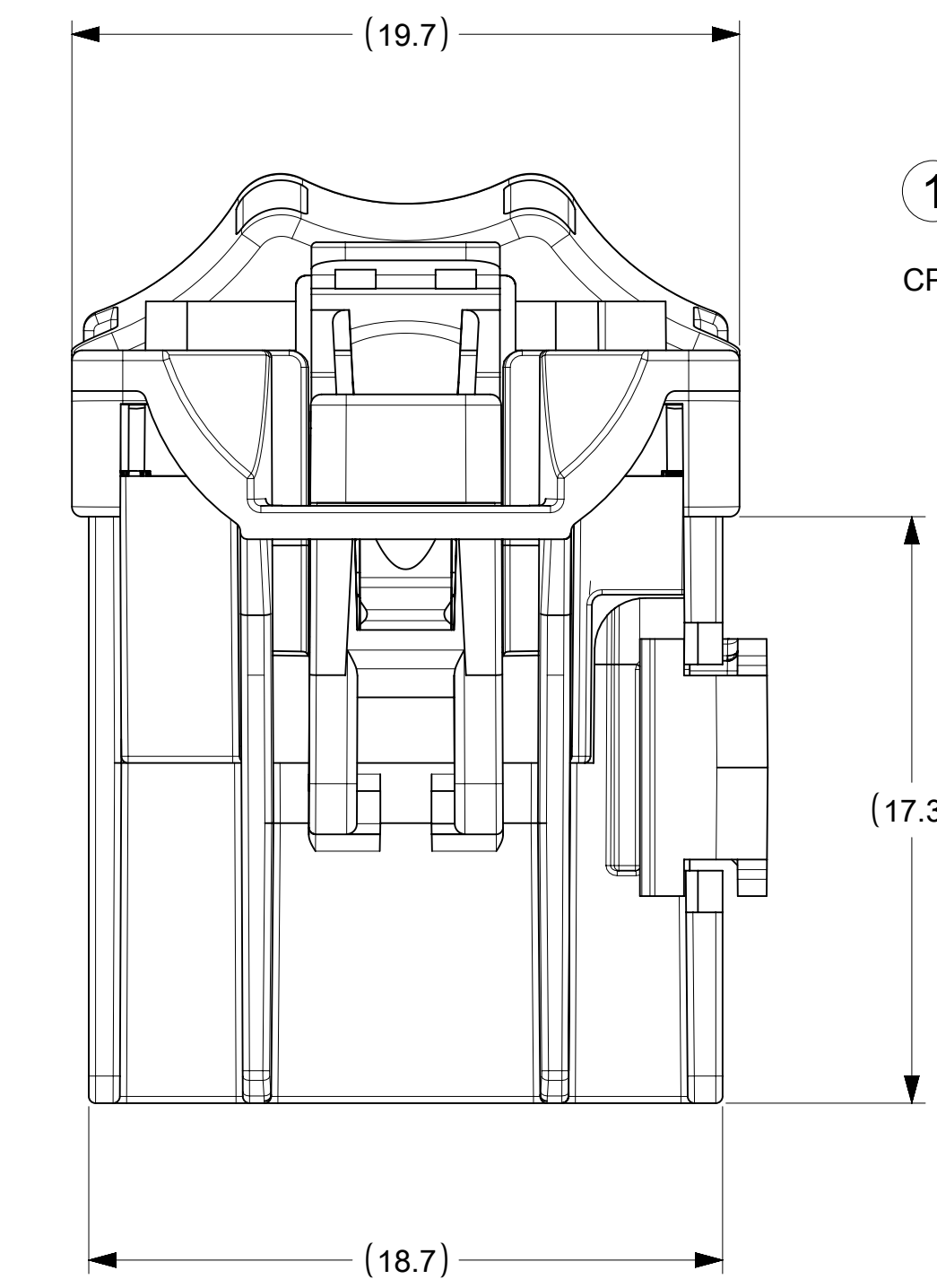
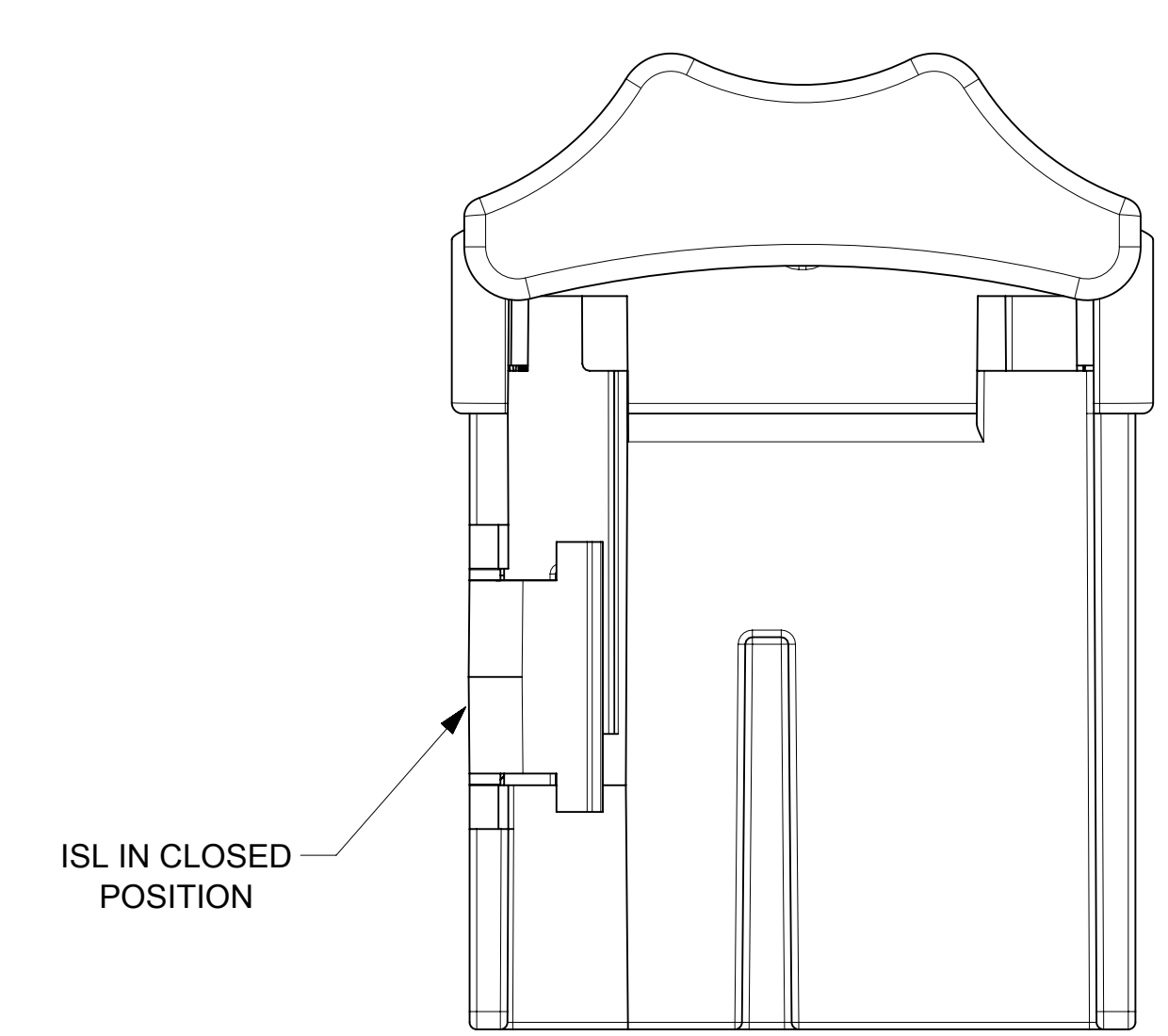
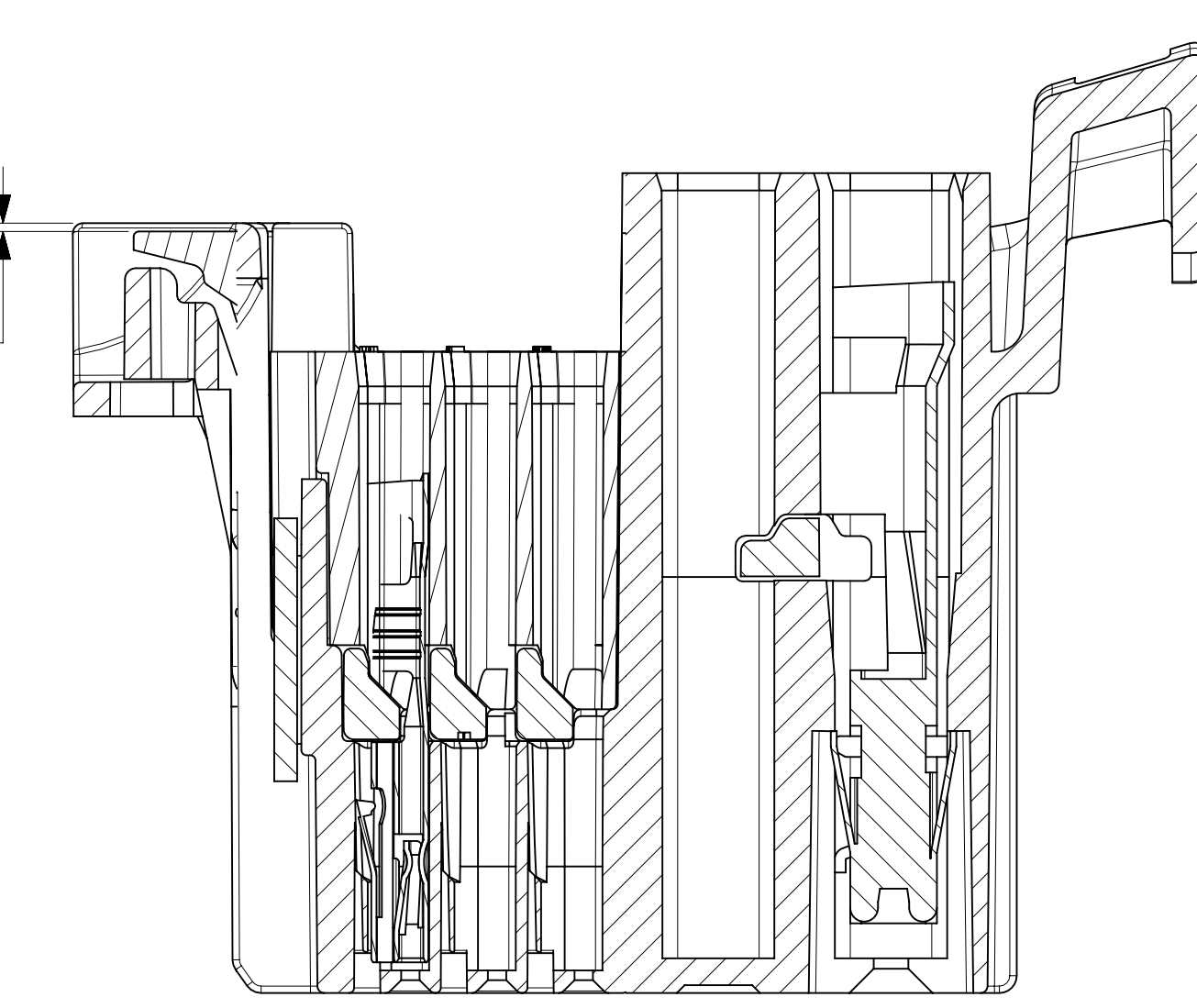
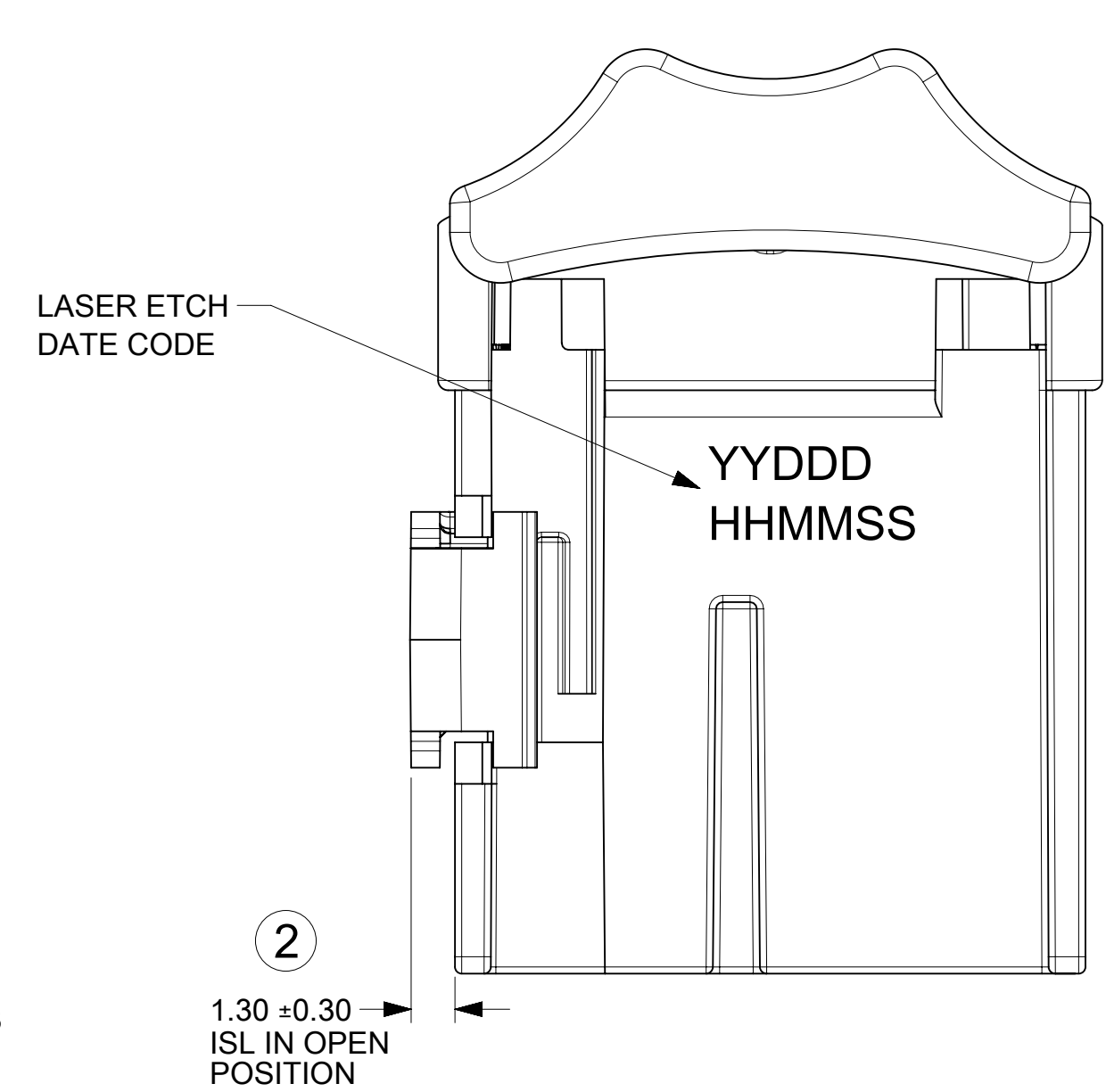
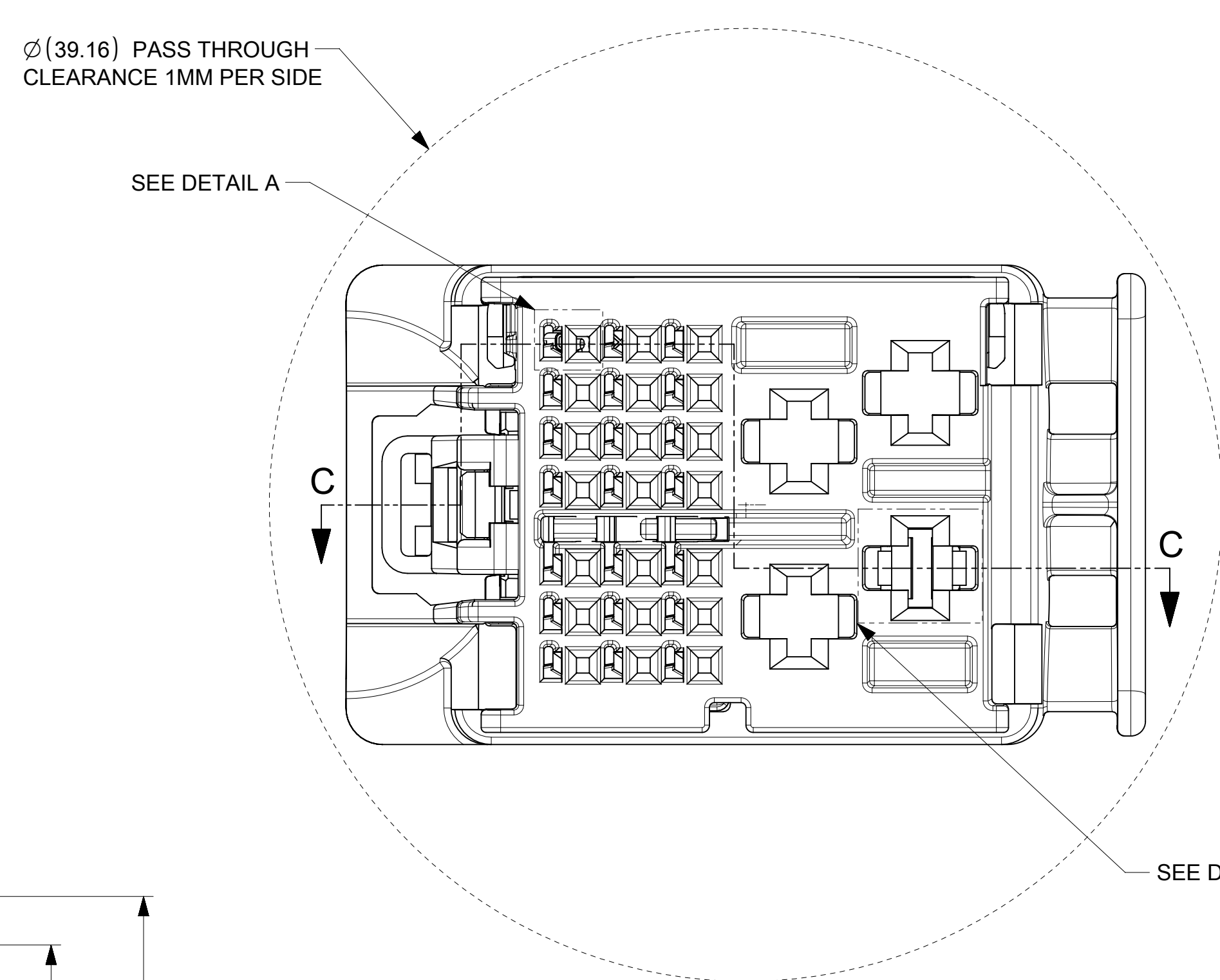
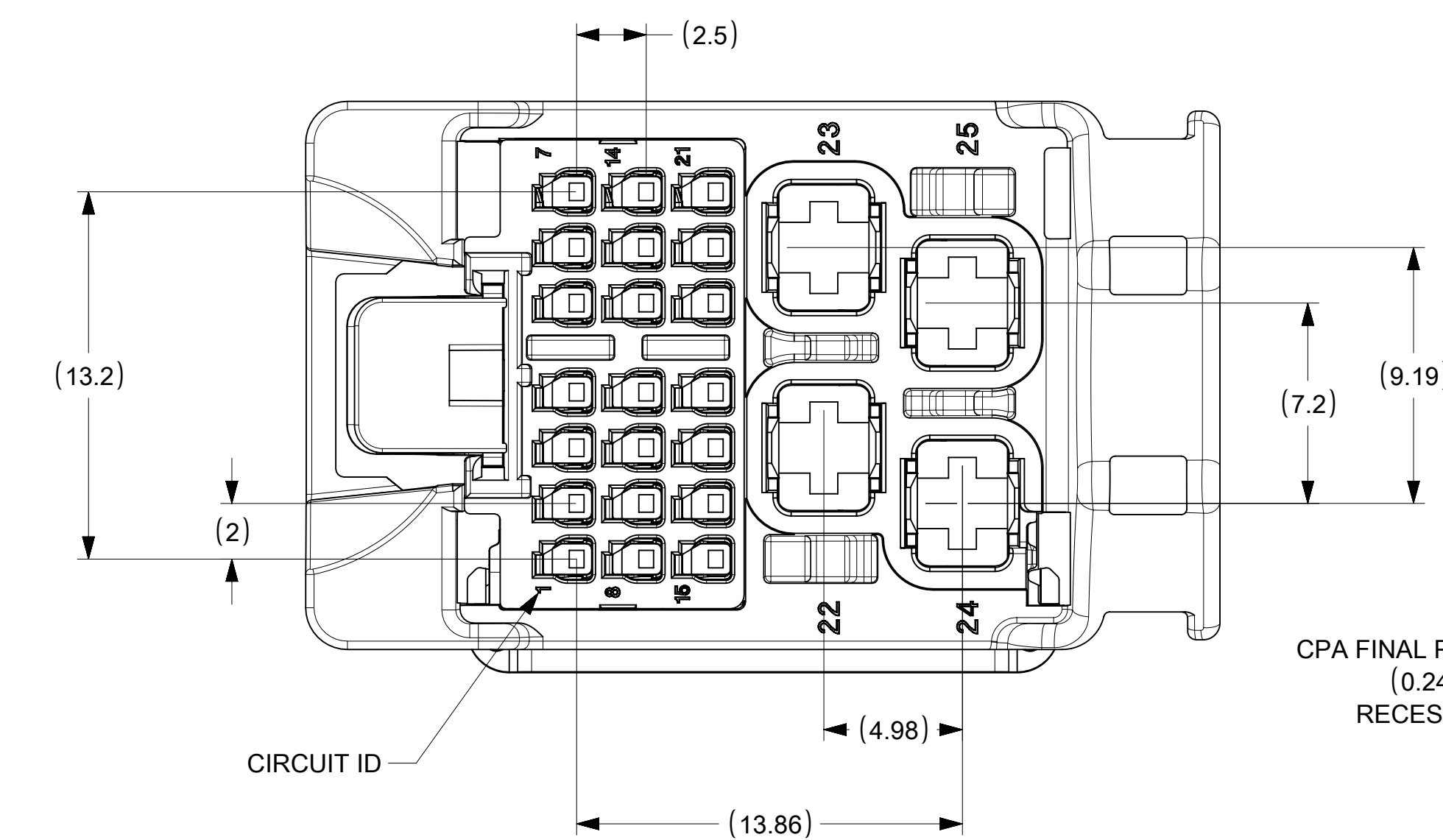
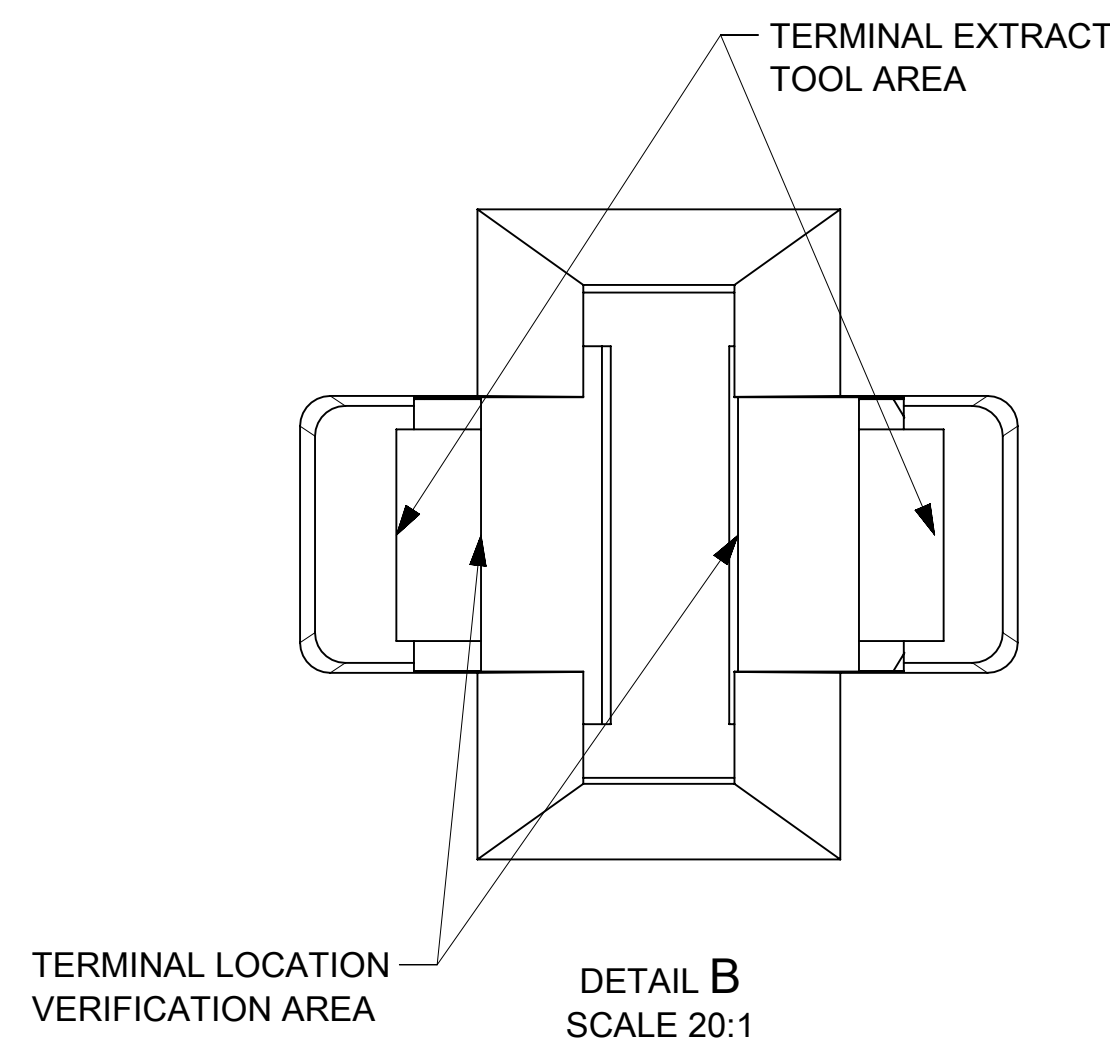
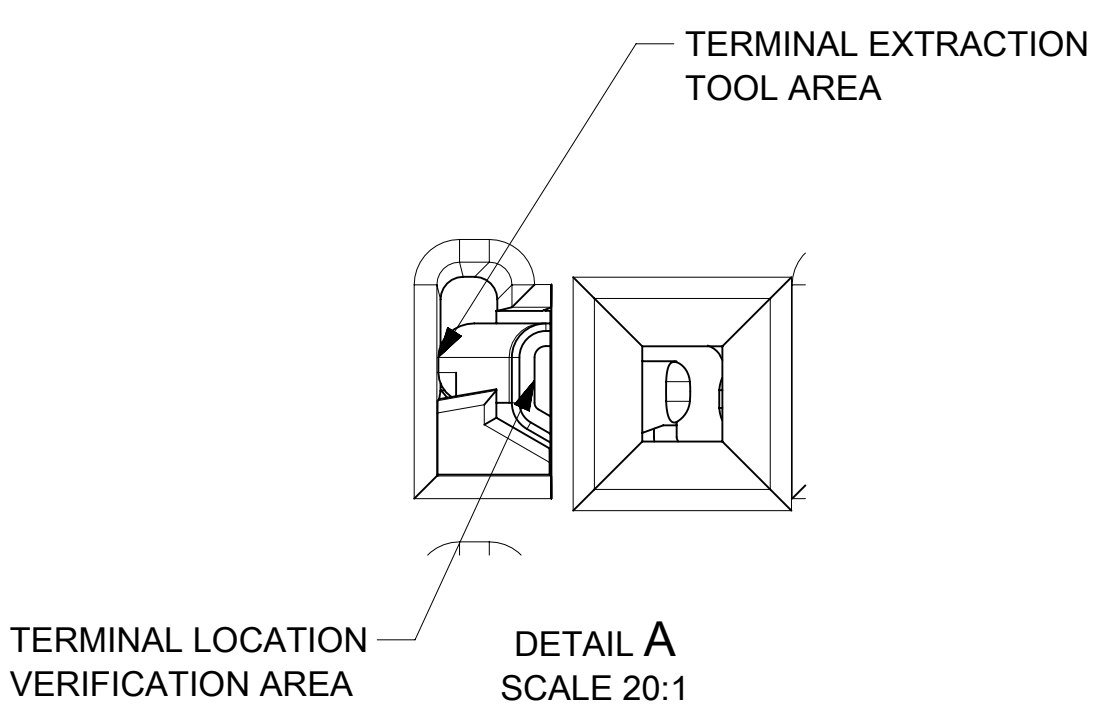

SYMBOLS		THIS DRAWING CONTAINS INFORMATION THAT IS PROPRIETARY TO MOLEX ELECTRONIC TECHNOLOGIES, LLC AND SHOULD NOT BE USED WITHOUT WRITTEN PERMISSION	
▽ = 0	DIMENSION UNITS	SCALE	CURRENT REV DESC: UPDATED TAK50
▽ = 0	mm	5:1	TERMINAL PNS
▽ = 0	GENERAL TOLERANCES (UNLESS SPECIFIED)		EC NO: 648438
▽ = 0	ANGULAR TOL ± 3.0°		DRWN: YPENG47 2021/07/21
▽ = 0	4 PLACES ±		CHK'D: RCARLSON 2021/07/29
▽ = 0	3 PLACES ±		APPR: JCONDON 2021/08/02
▽ = 0	2 PLACES ± 0.3		INITIAL REVISION:
▽ = 0	1 PLACE ± 0.3		DRWN: RCARLSON 2019/02/18
▽ = 0	0 PLACES ± 0.3		APPR: JCONDON 2019/02/25
■ = 0	DRAFT WHERE APPLICABLE MUST REMAIN WITHIN DIMENSIONS		THIRD ANGLE PROJECTION
▽ = 0	DRAWING		SERIES
▽ = 0	D-SIZE		160027
DOCUMENT NUMBER		DOC TYPE	DOC PART
1600270011		PSD	000
REVISION		A3	
MATERIAL NUMBER		CUSTOMER	SHEET NUMBER
SEE SHEET 1		GENERAL MARKET	2 OF 2

DOCUMENT STATUS	P1	RELEASE DATE	2021/08/02	13:46:02
-----------------	----	--------------	------------	----------

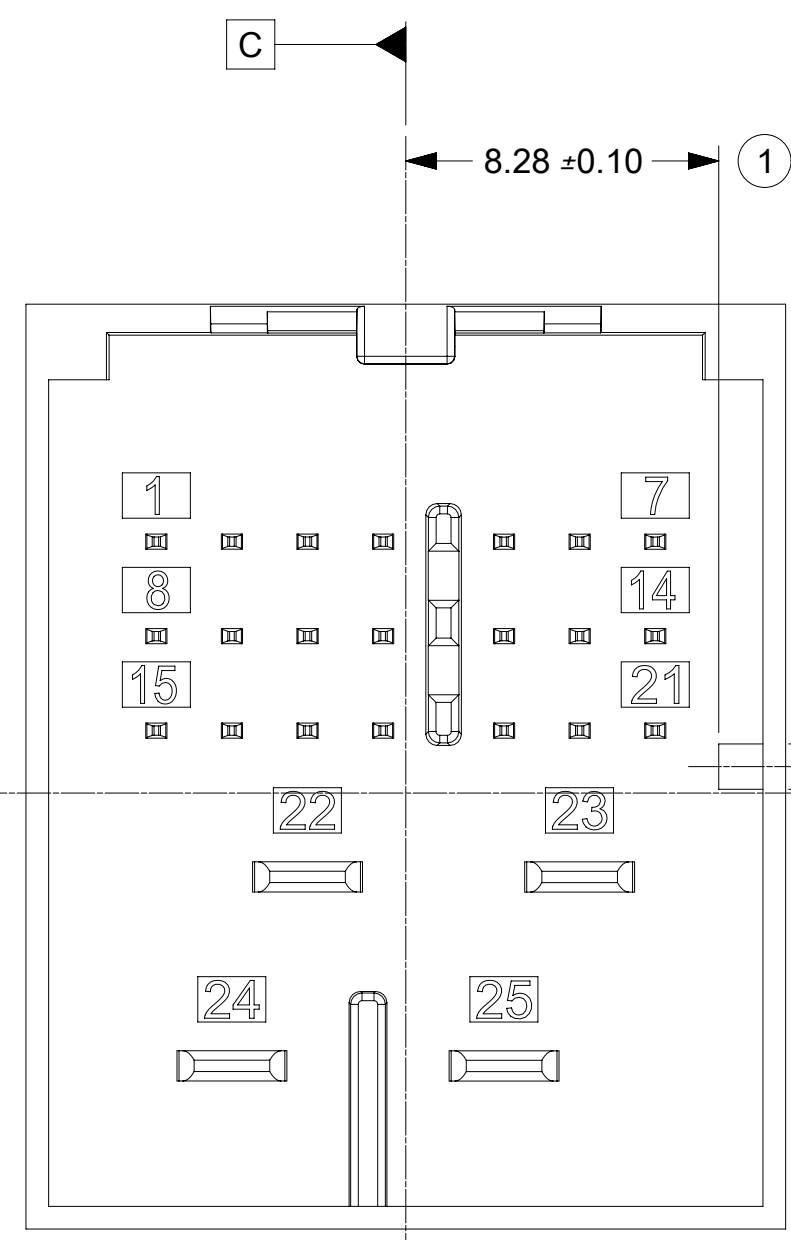

INTERFACE KEY 1 & KEY 5

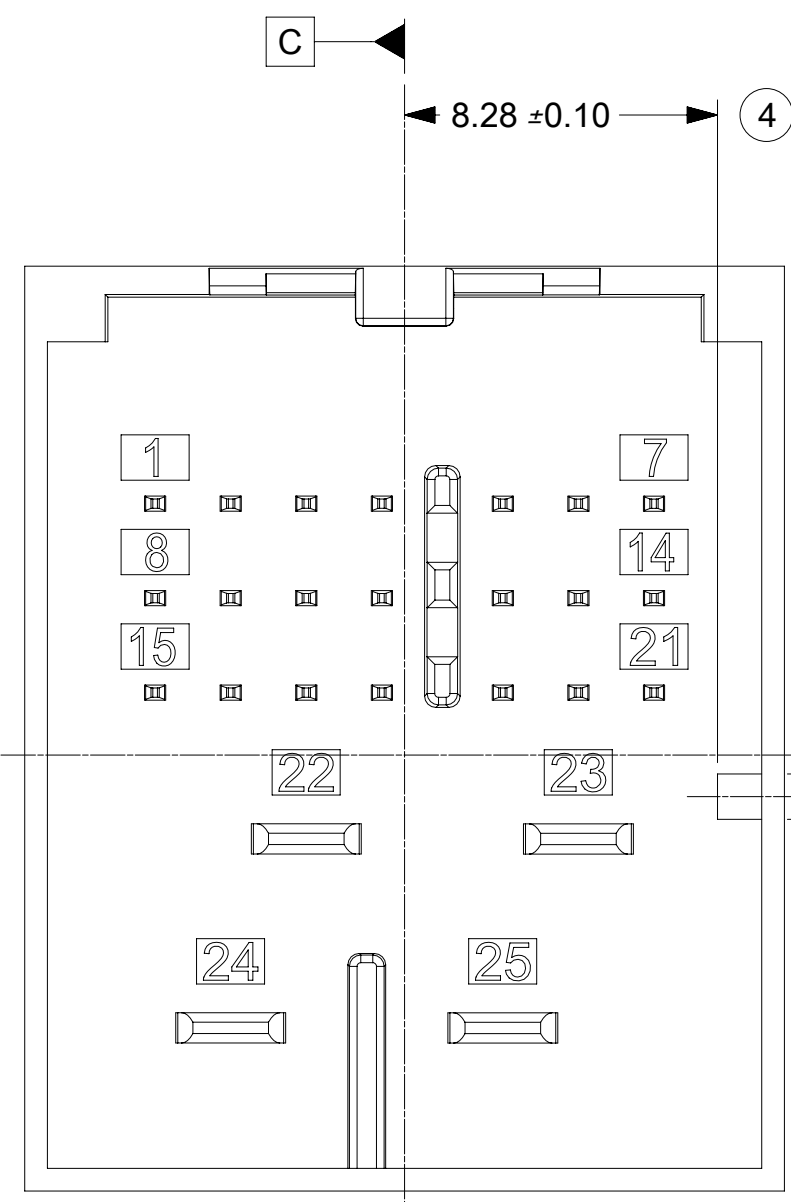

INTERFACE KEY 2 & KEY 6

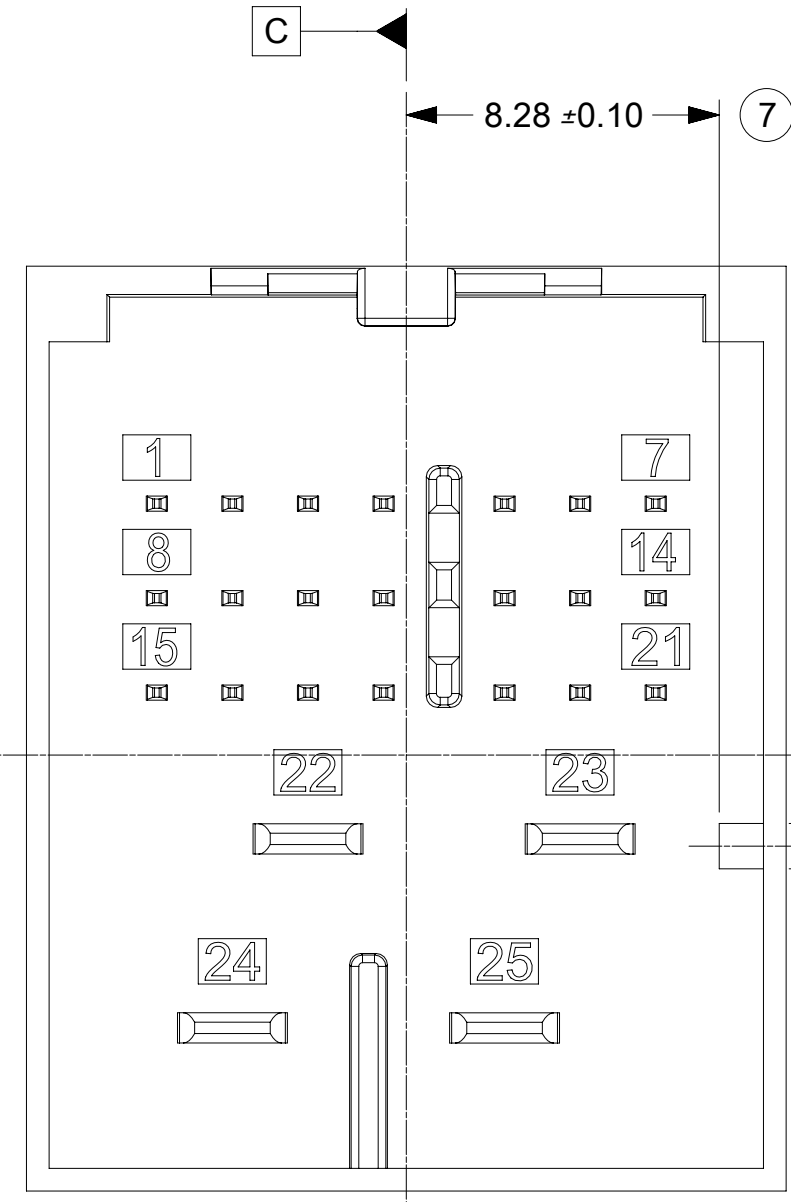

INTERFACE KEY 3 & KEY 7

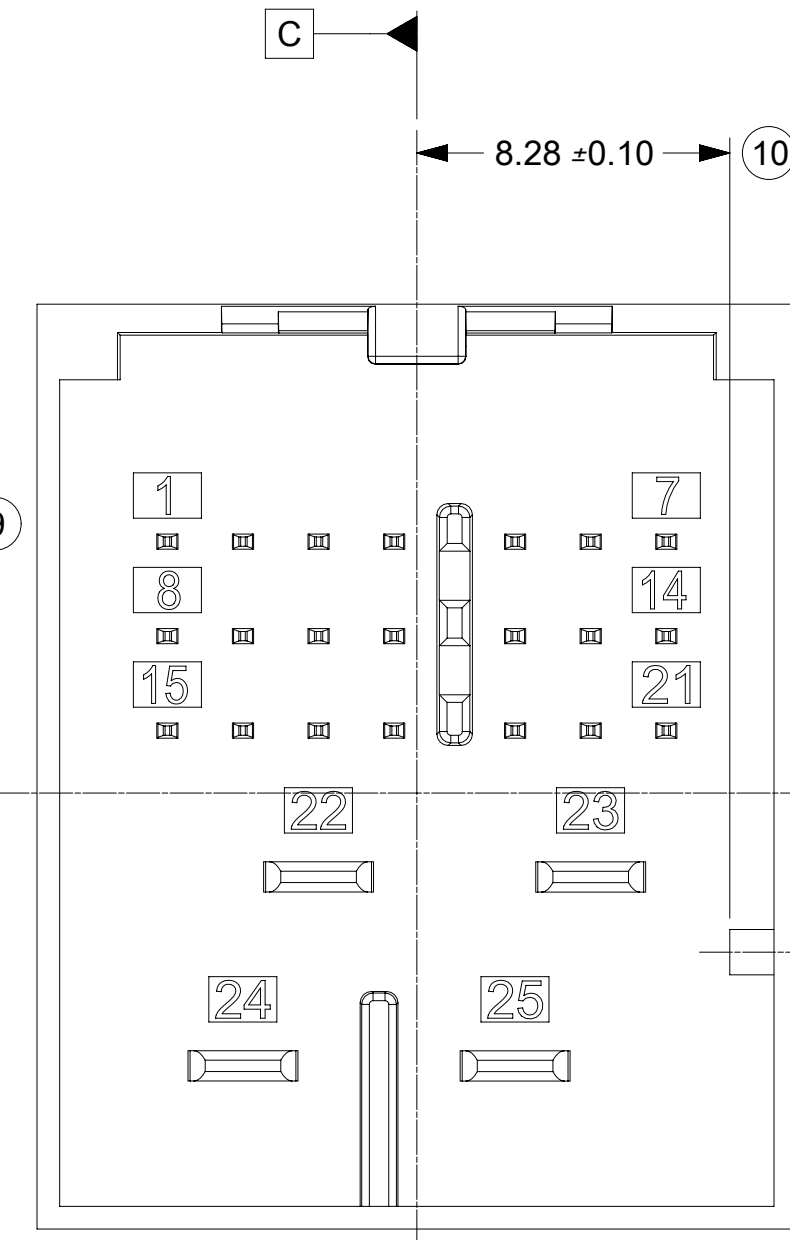

INTERFACE KEY 4 & KEY 8

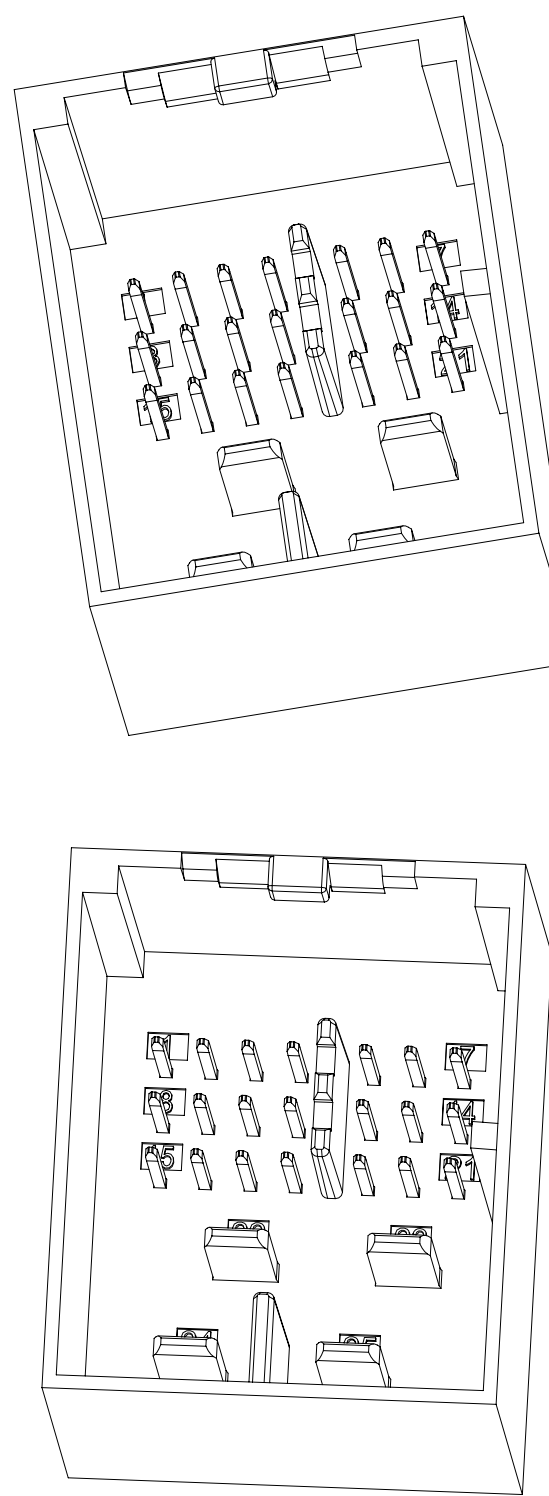

INTERFACE OPTIONS		
KEY	RIB OPTION	MATING CONNECTOR COLOR
1	OPTION A	LIGHT GREEN B
2	OPTION A	STONE GRAY
3	OPTION A	BLACK
4	OPTION A	DARK GRAY
5	OPTION B	DARK PURPLE A
6	OPTION B	TBD
7	OPTION B	TBD
8	OPTION B	LIGHT GRAY

NOTES: VALID UNLESS OTHERWISE SPECIFIED

1. DESIGN - MATERIALS:

- a. RESIN MATERIAL : PBT+GF30 OR SPS+GF30 OR EQUIVALENT
- b. PIN/BLADE MATERIAL : ACCORDING TO USCAR DRAWING EWCAP-001 NOTE B2
- c. PLATING: ACCORDING TO USCAR DRAWING EWCAP-001 TIN REFLOW WITH UNDERPLATE
- d. PIN TIPS ACCORDING TO USCAR DRAWING EWCAP-001 (050-T001 & 280-T001)
- e. DEVIATION TO EWCAP-001 ACCEPTABLE IF PERFORMANCE (ELECTRICAL/MECHANICAL) IS SHOWN TO BE EQUAL OR BETTER AS REQUIRED BY VALIDATION TESTING.
- Ⓢ 1. DEVIATION TO TIN PLATING THICKNESS AS NECESSARY TO MEET MATING FORCE AND ALL VALIDATION REQUIREMENTS

2. DRAWING - GEOMETRY:

- a. ALL GRAPHIC DATA IS BASIC (NO TOLERANCE) AND MUST BE TAKEN FROM THE DATA FILE AT ITS LATEST REVISION.
- b. GEOMETRIC DIMENSIONS AND TOLERANCES PER ASME Y14.5M-2009.
- c. GENERAL TOLERANCES:
 LINEAR : PER DIN 16901 LINEAR CODE B FOR PRECISION ENGINEERING
 ANGULAR : ±3°
- d. EDGES AND UNDIMENSIONED DETAILS PER ISO13715
- e. CORNERS SHOW AS SHARP TO BE R 0.2 MAX.
- f. LETTERS SHALL BE 0.2 MAX RAISED IN 0.25 MAX RECESSED PAD.
 THIS INCLUDES RECYCLING CODE, CAVITY ID, VENDOR IDENTIFICATION, AND CUSTOMER MATERIAL NUMBER.

3. DESIGN - MANUFACTURING:

- a. DRAFT TO BE WITHIN TOLERANCE.

C1	UPDATED BASIC DIMENSIONS IN SECTION B-B ON SHEET 2 ECN: 649575 11/19/2020 YPENG47
C	ADDED 2.8MM BLADE LENGTH VARIANT FOR MATE FORCE REQUIREMENT ADDED NOTE 1.E.1 CHANGE RECORD: 626144 JPATE 10/22/2019
B1	ADDED BALLOONS JCONDON 08/02/2018
B	REMOVED 0.2MM FROM CONNECTOR LOCK TAB FEATURE
A2	ADDED CIRCUIT IDs
A1	ADDED NOTE 1e, MKOWALSKY 7/7/2017
8	GEOMETRY UPDATED , SPEMMARAJU 02/18/2016
7	UAU2016-1146 SAP # 10681629 JCONDON 03/25/2015

INSPECTION BALLOON NUMBER LOG	
PER DRAWING REVISION:	C1
LAST BALLOON NUMBER:	63
ADDED BALLOON NUMBER:	NONE
DELETED BALLOON NUMBER:	NONE

FUNCTIONAL SYMBOLS	THIS DRAWING CONTAINS INFORMATION THAT IS PROPRIETARY TO MOLEX ELECTRONIC TECHNOLOGIES, LLC AND SHOULD NOT BE USED WITHOUT WRITTEN PERMISSION
FA = 0	DIMENSION UNITS: mm SCALE: 5:1
FE = 0	GENERAL TOLERANCES (UNLESS SPECIFIED)
FP = 0	ANGULAR TOL ± °
DIVISIONAL SYMBOLS	4 PLACES ±
	3 PLACES ±
	2 PLACES ±
	1 PLACE ±
	0 PLACES ±
DRAFT WHERE APPLICABLE MUST REMAIN WITHIN DIMENSIONS	THIRD ANGLE PROJECTION
	DRAWING SERIES: D-SIZE 160027
	CURRENT REV DESC: UPDATED BASIC DIMENSIONS IN SECTION B-B ON SHEET 2
	EC NO: 649575
	DRWN: YPENG47 2020/11/19
	CHK'D: JRUTTER 2020/11/23
	APPR: MVANSLAMBROU 2020/11/25
	INITIAL REVISION:
	DRWN: SPEMMARAJU 2015/11/03
	APPR: KDEKOSKI 2016/03/24
	MATERIAL NUMBER: SD-160027-002
	CUSTOMER: GENERAL MARKET
	DOC TYPE: PSD
	DOC PART: 000
	REVISION: C1
	SHEET NUMBER: 1 OF 3

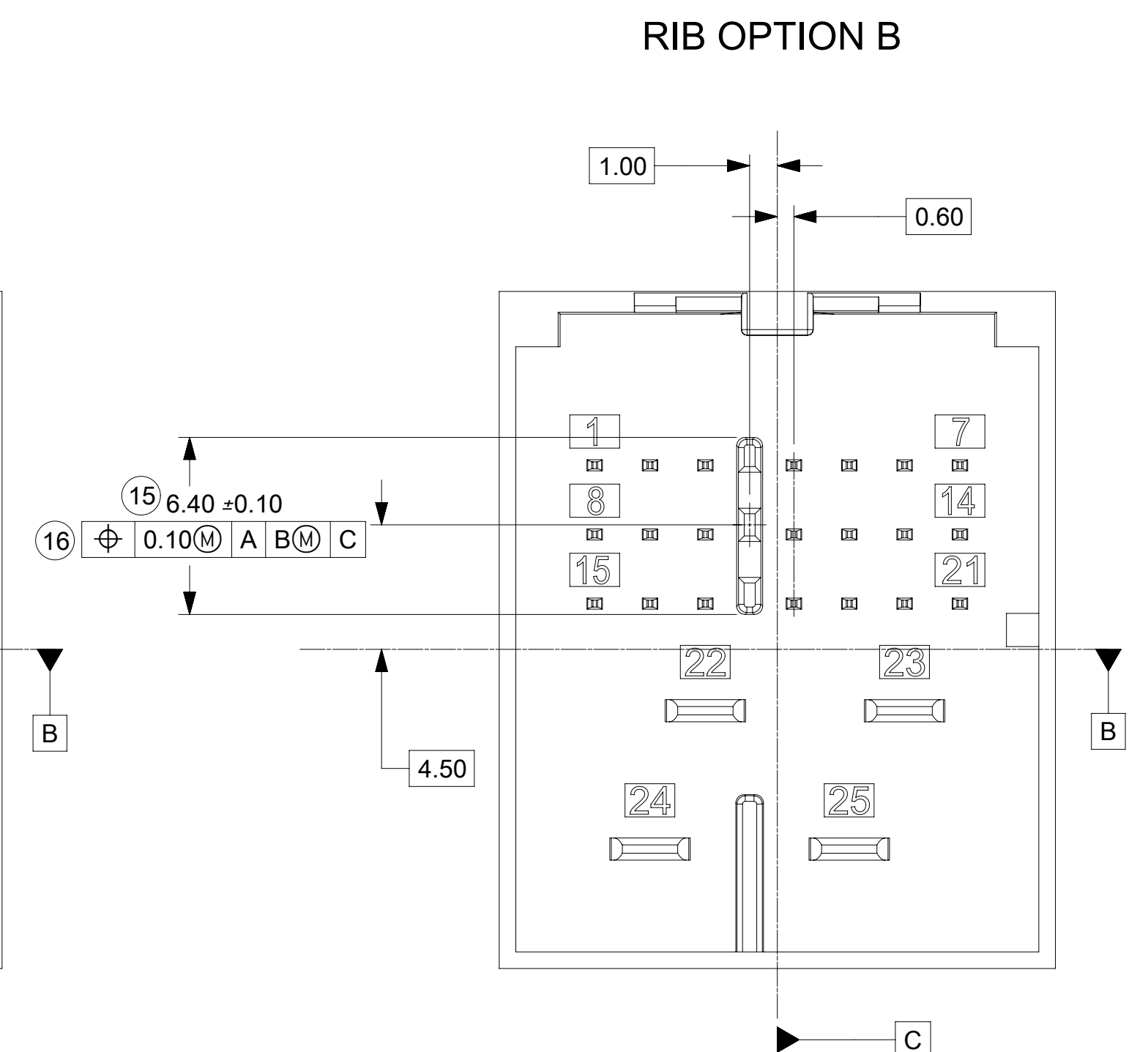
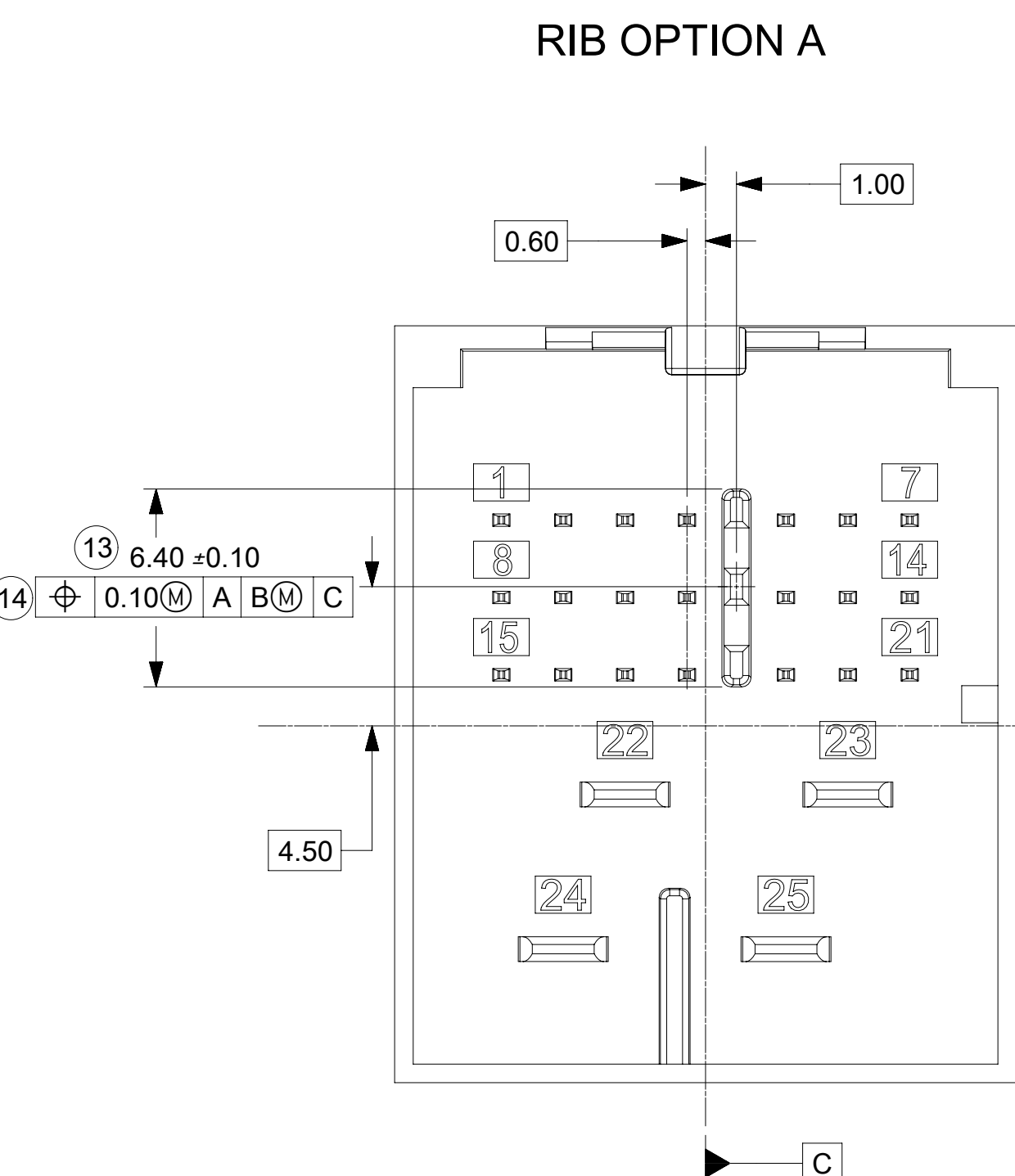

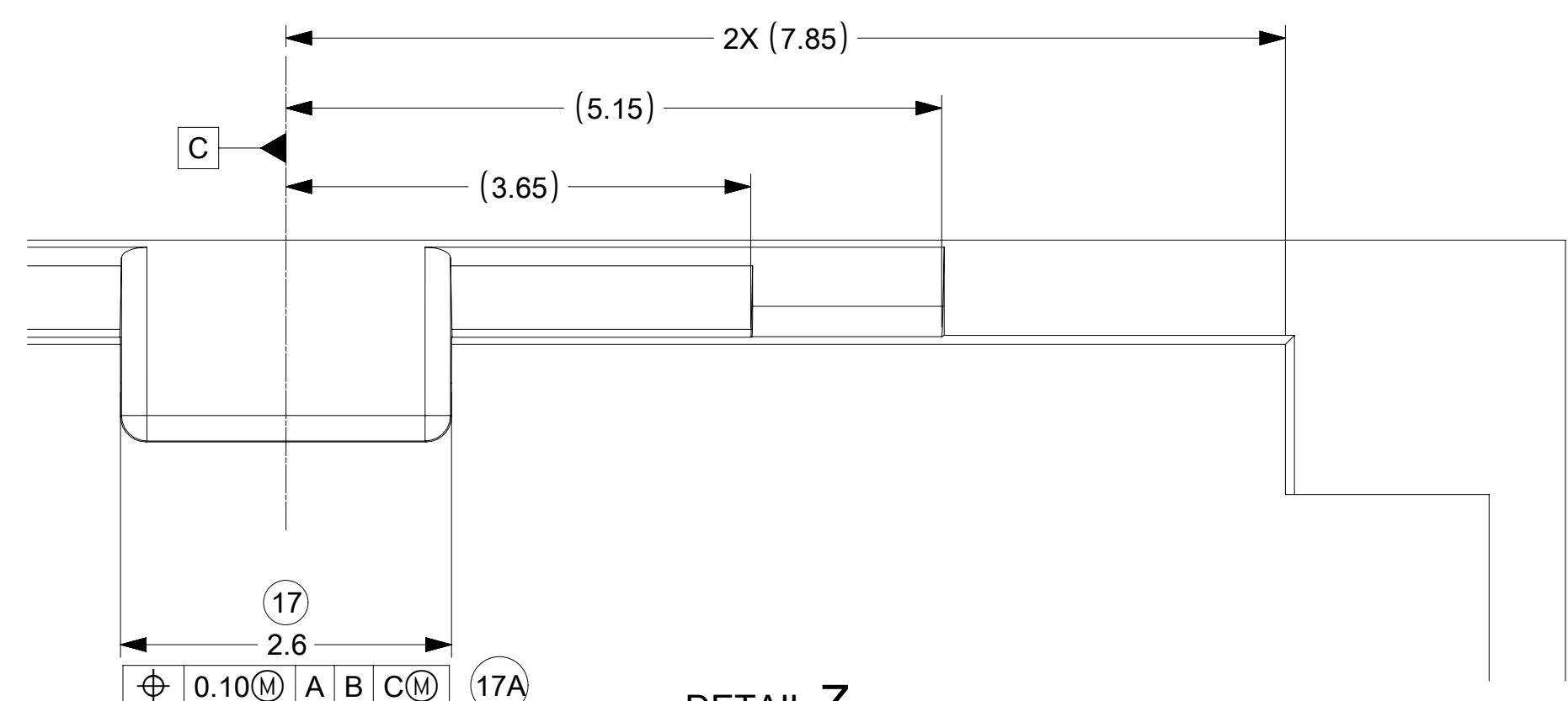

DETAIL Z
SCALE 20:1

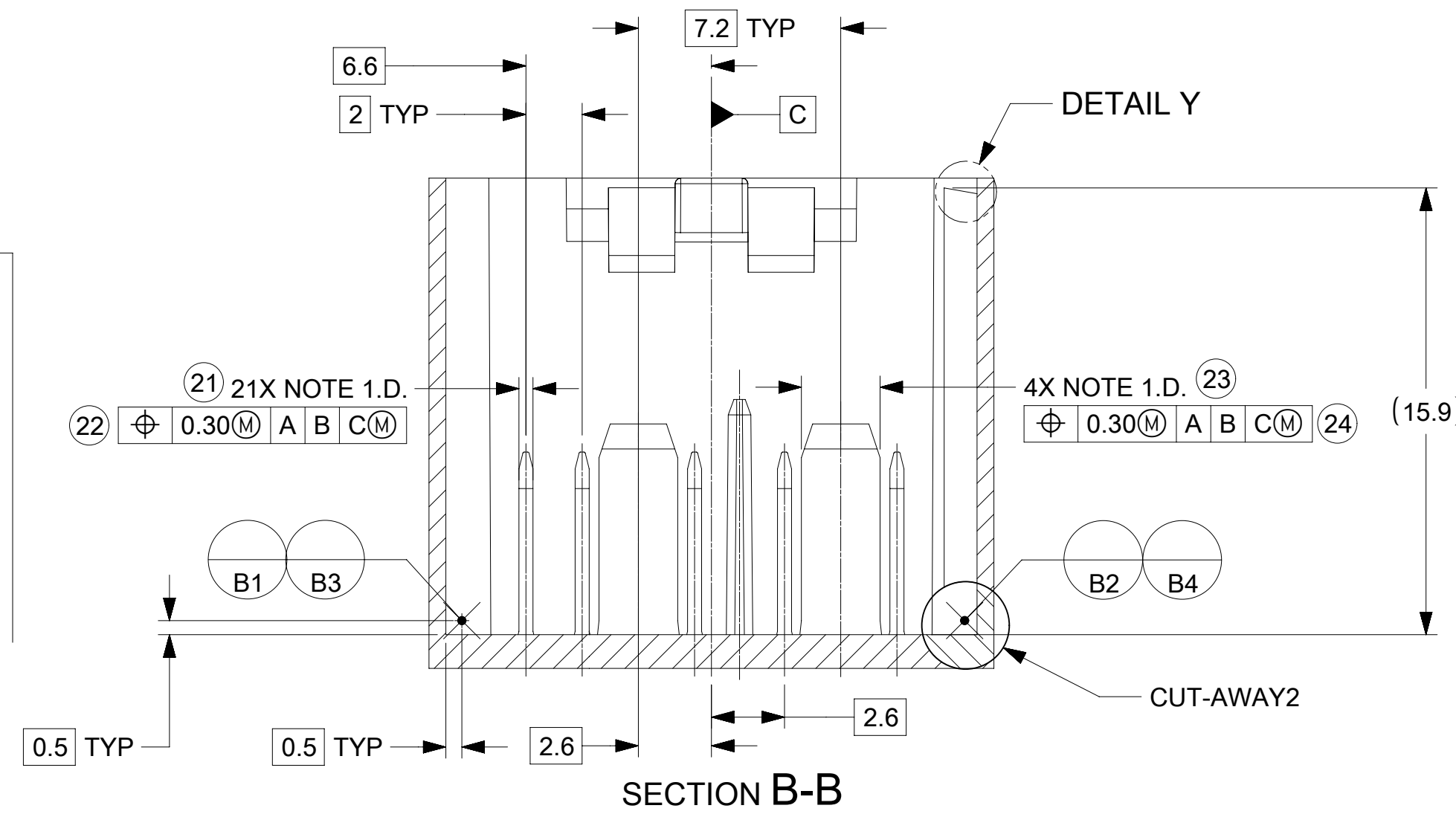

SECTION B-B

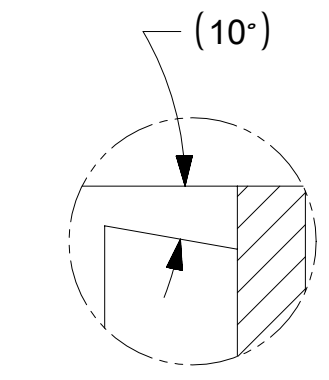

DETAIL Y
SCALE 15:1

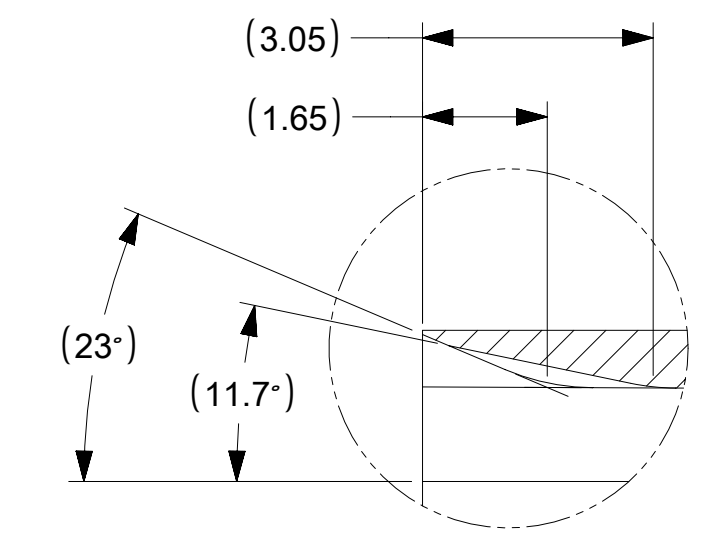

DETAIL X
SCALE 10:1

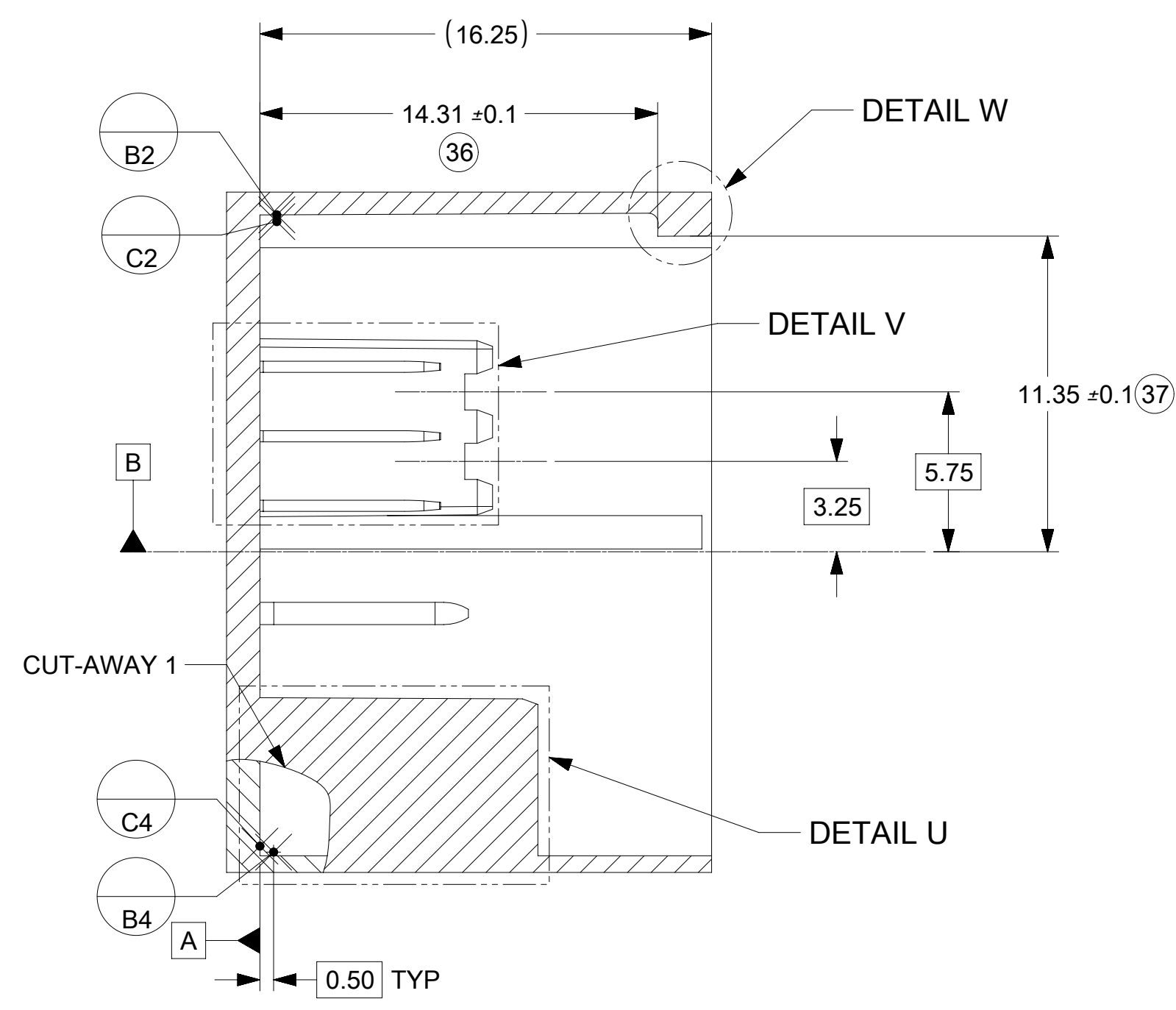

SECTION A-A

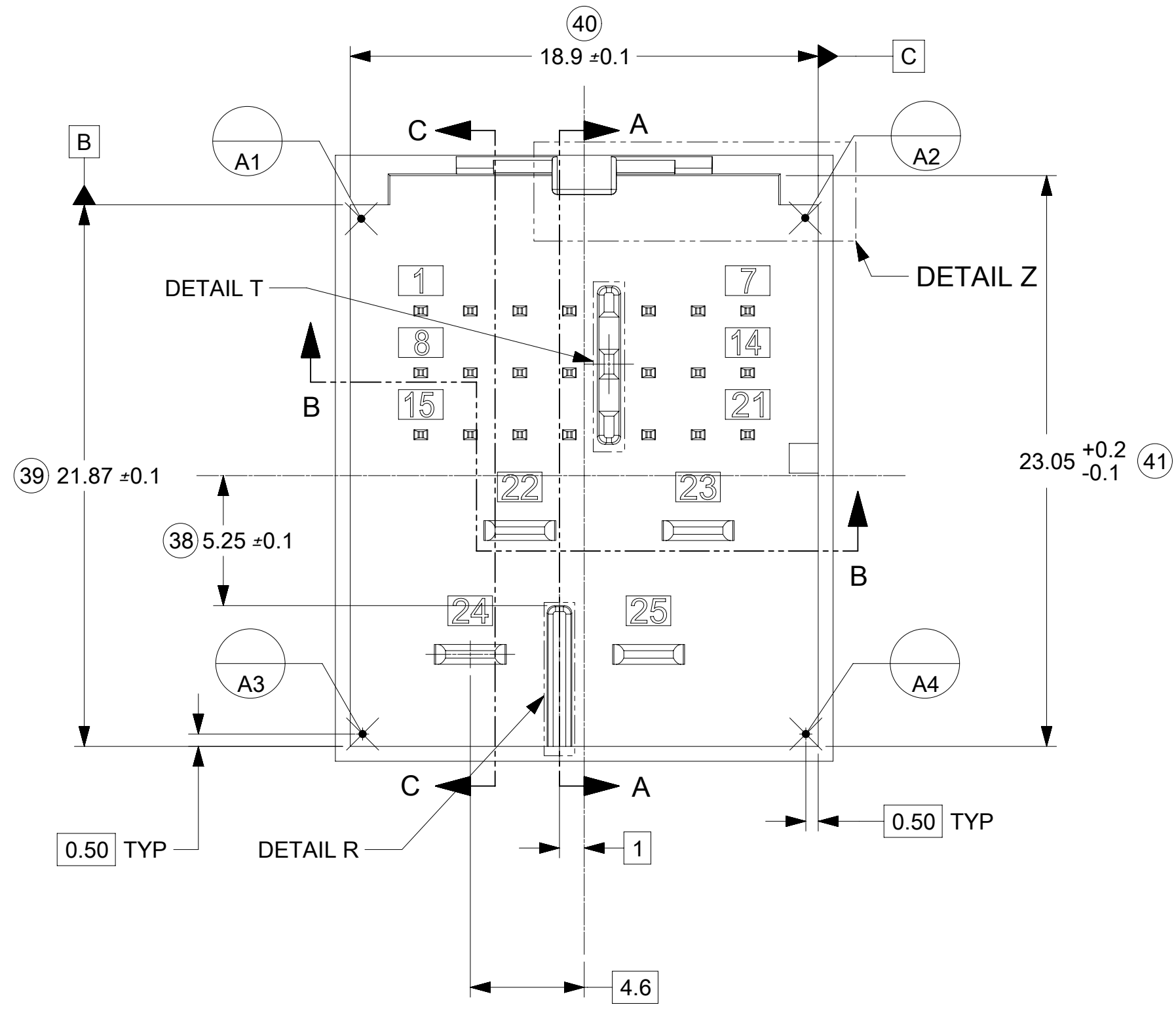

SECTION C-C

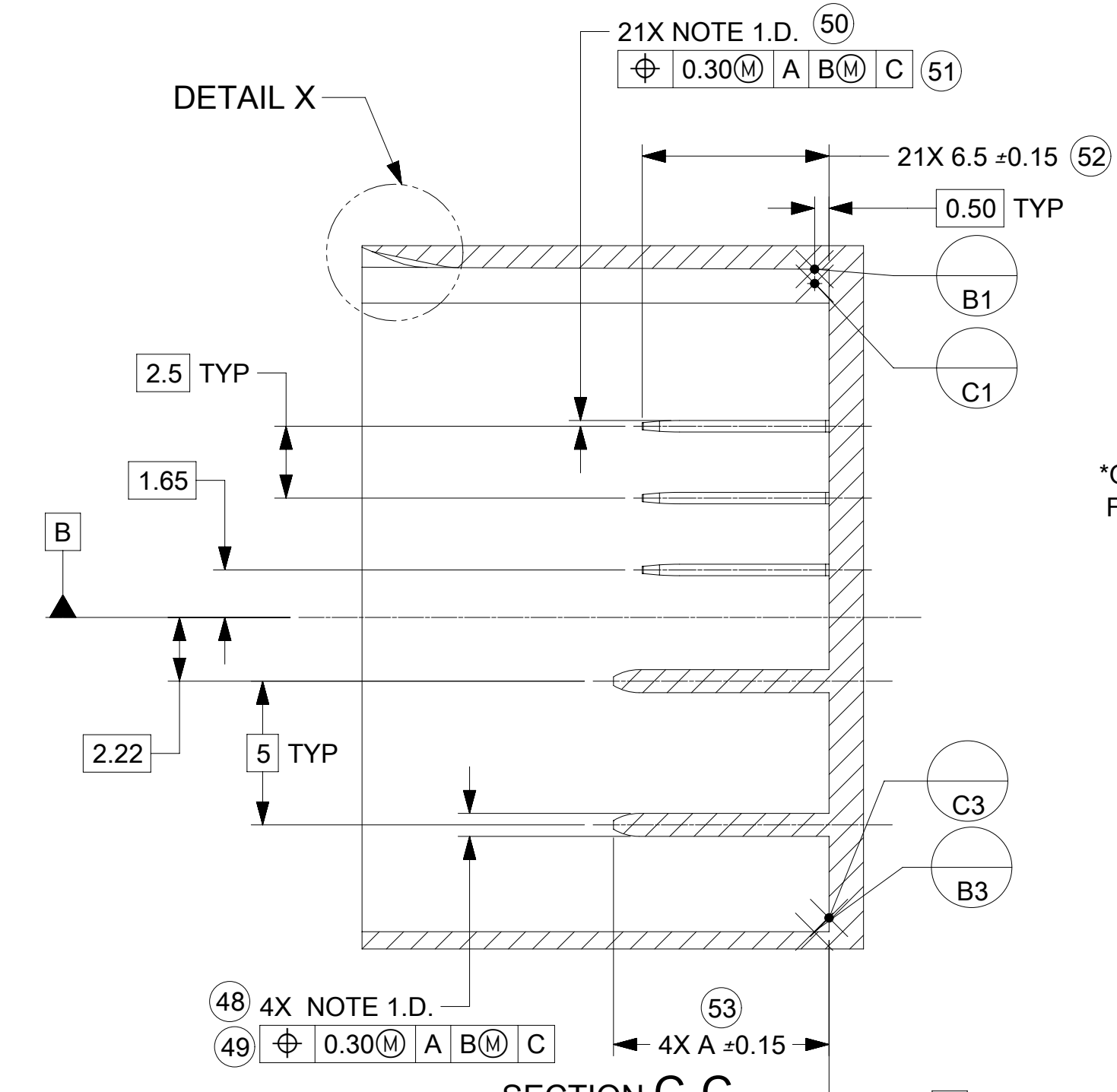

SECTION C-C

CONSTRUCTION	DIM. A (mm)	STATUS
OPTION A	7.5	REVISION B
OPTION B	6.5	REVISION C

*OPTION B IS THE PREFERRED CONSTRUCTION FOR ALL NEW HEADERS

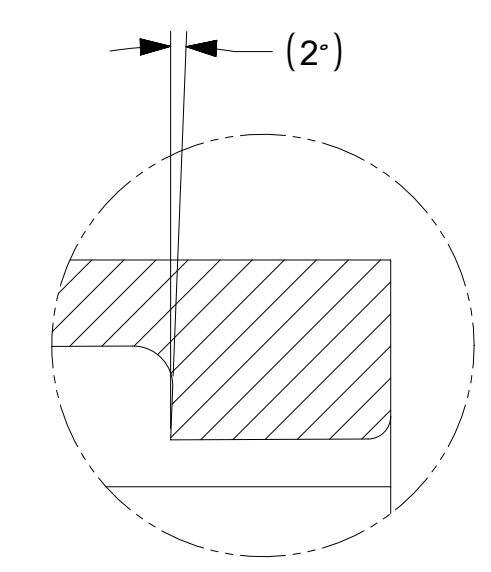

DETAIL W
SCALE 15:1

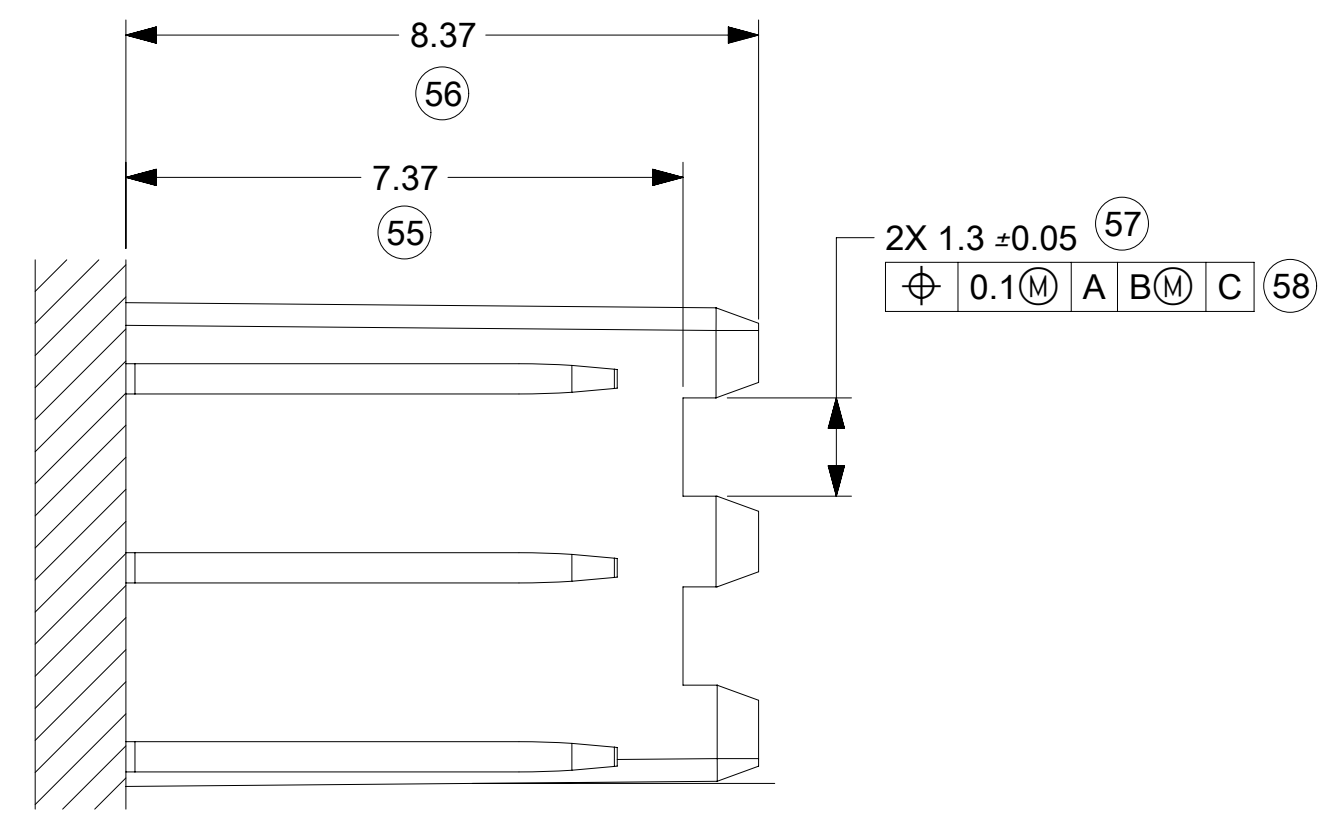

DETAIL V
SCALE 10:1

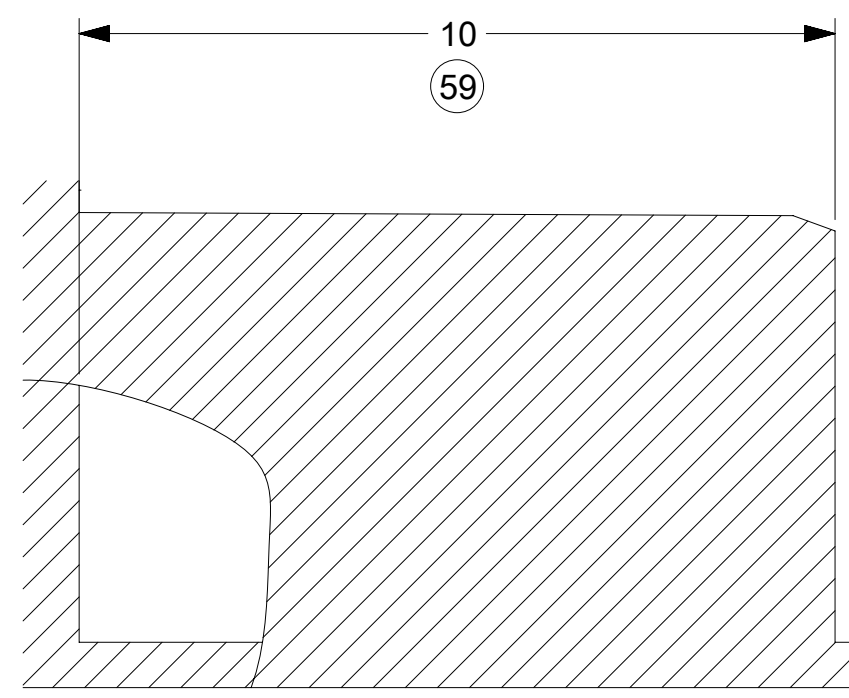

DETAIL U
SCALE 10:1

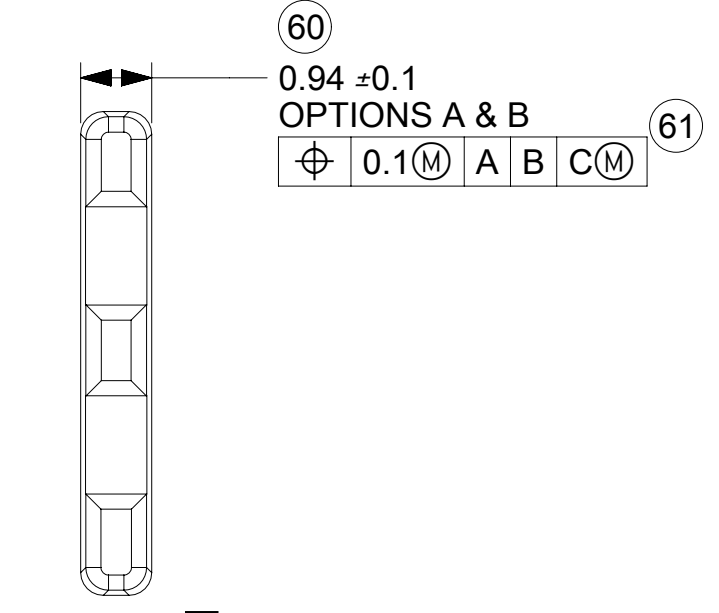

DETAIL T
SCALE 10:1

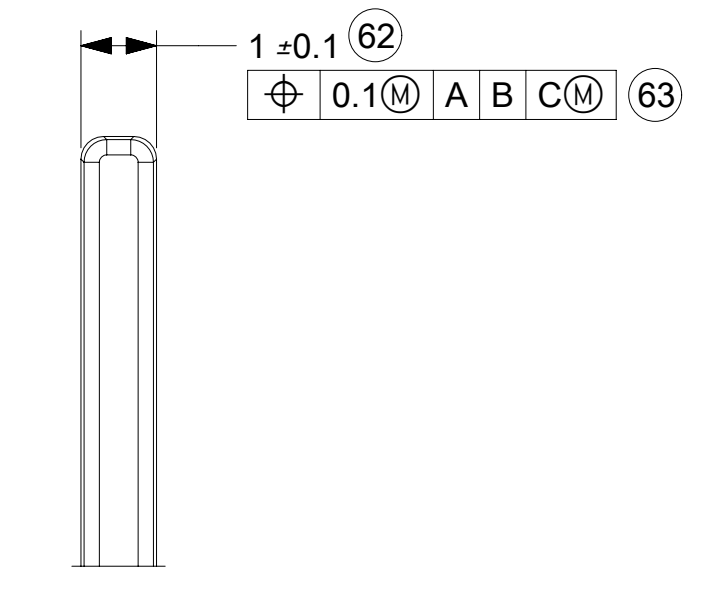

DETAIL R
SCALE 10:1

FUNCTIONAL SYMBOLS FA = 0 FC = 0 FD = 0	THIS DRAWING CONTAINS INFORMATION THAT IS PROPRIETARY TO MOLEX ELECTRONIC TECHNOLOGIES, LLC AND SHOULD NOT BE USED WITHOUT WRITTEN PERMISSION	SCALE 5:1	CURRENT REV DESC: UPDATED BASIC DIMENSIONS IN SECTION B-B ON SHEET 2		
	DIMENSION UNITS mm	GENERAL TOLERANCES (UNLESS SPECIFIED)	EC NO: 649575		
DIVISIONAL SYMBOLS	ANGULAR TOL ± °	4 PLACES ±	3 PLACES ±	2 PLACES ±	1 PLACE ±
	0 PLACES ±	DRAFT WHERE APPLICABLE MUST REMAIN WITHIN DIMENSIONS		THIRD ANGLE PROJECTION	DRAWING SERIES D-SIZE 160027
DRWN: YPENG47 CHK'D: JRUTTER APPR: MVANSLAMBROU		2020/11/19 2020/11/23 2020/11/25	molex		
DRWN: SPEMMARAJU APPR: KDEKOSKI		2015/11/03 2016/03/24	25WAY STAK50H INTERFACE DRAWING		
INITIAL REVISION:		PRODUCT CUSTOMER DRAWING			
DRAFT WHERE APPLICABLE MUST REMAIN WITHIN DIMENSIONS		DOCUMENT NUMBER SD-160027-002		DOC TYPE PSD	DOC PART 000
MATERIAL NUMBER GENERAL MARKET		CUSTOMER GENERAL MARKET		REVISION C1	SHEET NUMBER 2 OF 3

PACKAGE SPACE
FOR UNMATED
CONNECTOR

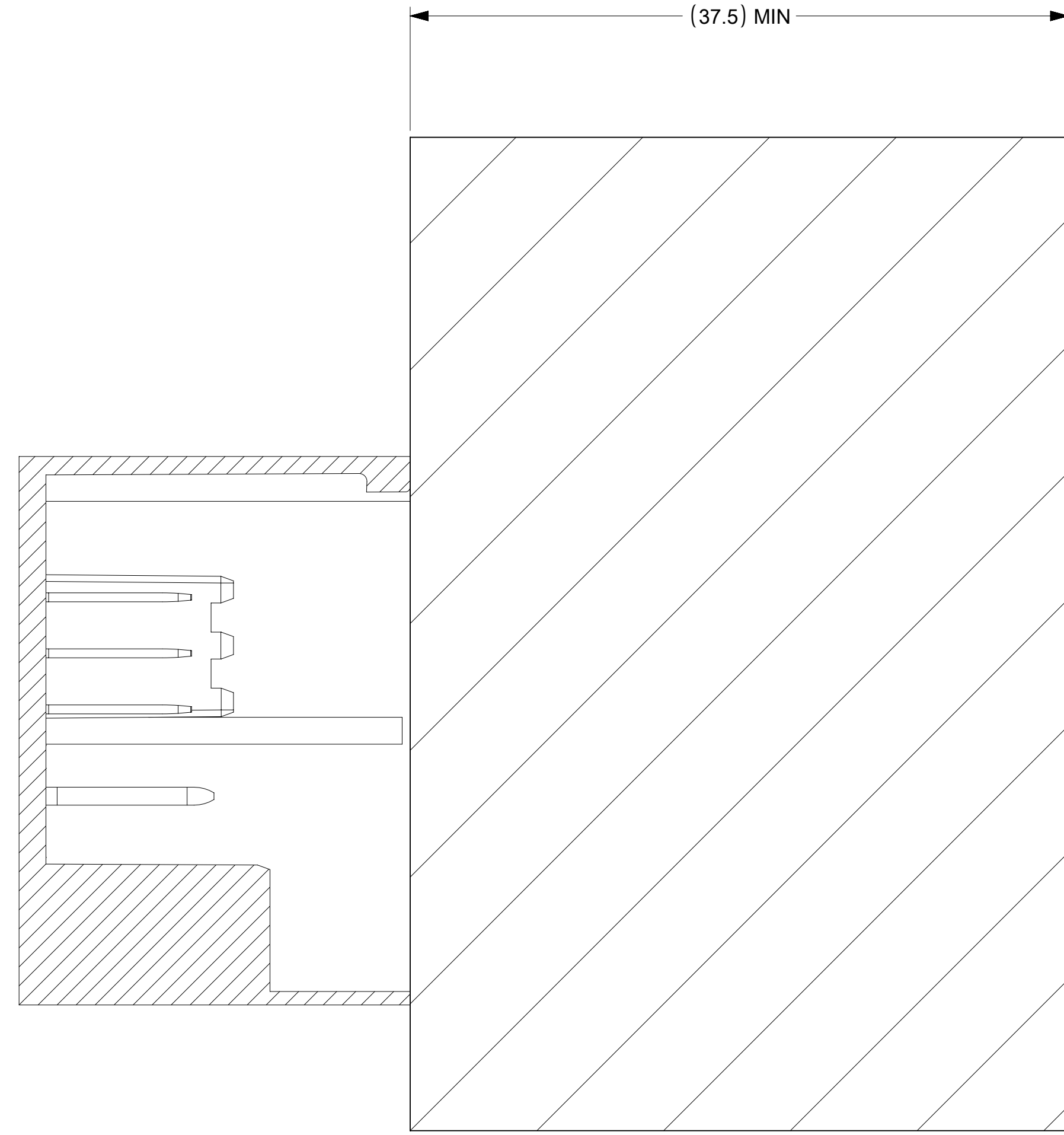

PACKAGE SPACE
FOR CONNECTOR

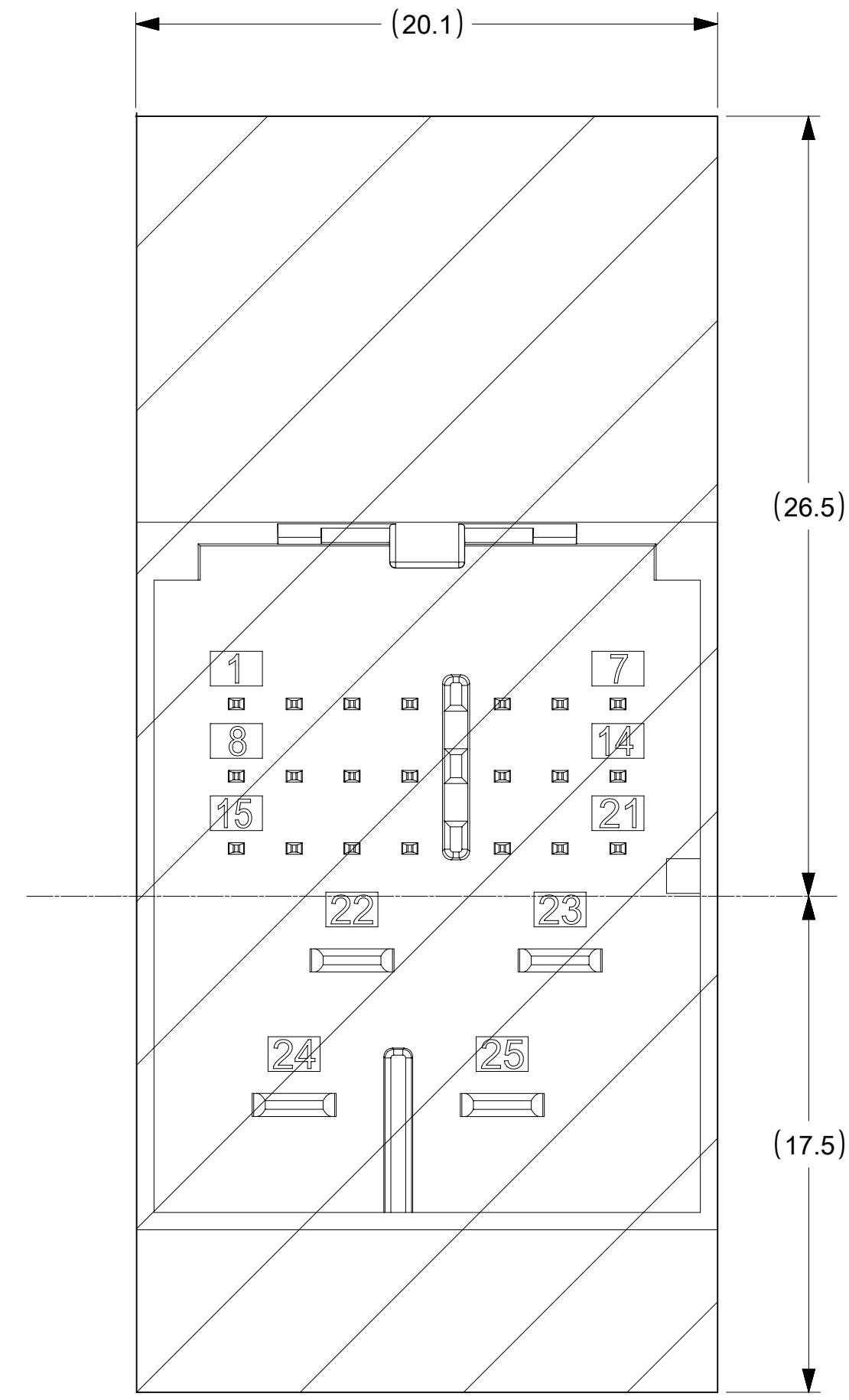

PACKAGE SPACE FOR
MATED CONNECTOR
WITH COVER

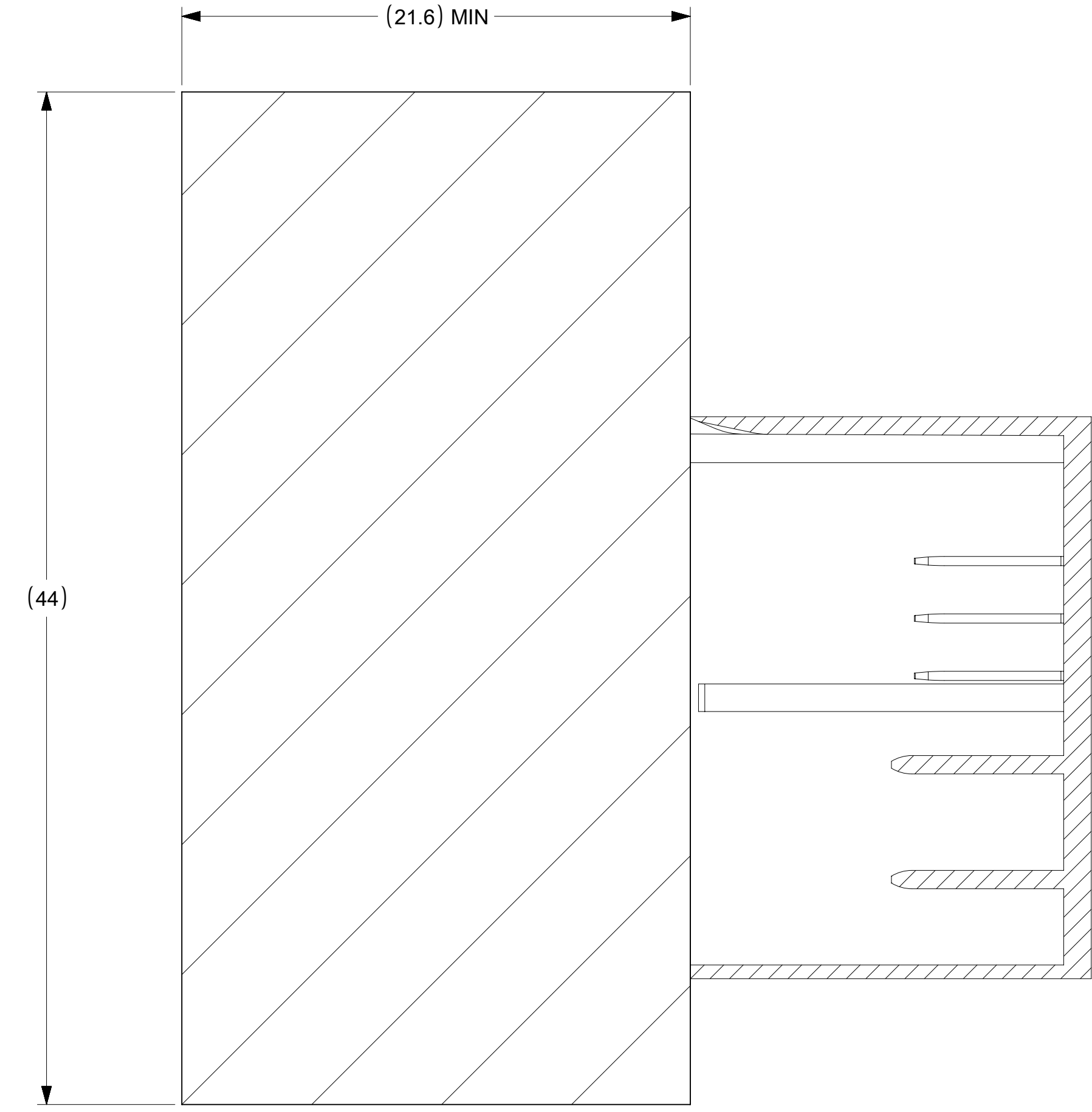

FUNCTIONAL SYMBOLS $F_A = 0$ $F_C = 0$ $F_P = 0$ DIVISIONAL SYMBOLS	THIS DRAWING CONTAINS INFORMATION THAT IS PROPRIETARY TO MOLEX ELECTRONIC TECHNOLOGIES, LLC AND SHOULD NOT BE USED WITHOUT WRITTEN PERMISSION		CURRENT REV DESC: UPDATED BASIC DIMENSIONS IN SECTION B-B ON SHEET 2			
	DIMENSION UNITS mm	SCALE 1:1	GENERAL TOLERANCES (UNLESS SPECIFIED)			
	ANGULAR TOL ± °		4 PLACES ±		INITIAL REVISION: DRWN: SPEMMARAJU 2015/11/03 APPR: KDEKOSKI 2016/03/24	
	3 PLACES ±		2 PLACES ±		DOCUMENT NUMBER SD-160027-002	
2 PLACES ±		1 PLACE ±		DOC TYPE DOC PART REVISION PSD 000 C1		
1 PLACE ±		0 PLACES ±		MATERIAL NUMBER CUSTOMER SHEET NUMBER 160027 GENERAL MARKET 3 OF 3		
DRAFT WHERE APPLICABLE MUST REMAIN WITHIN DIMENSIONS		THIRD ANGLE PROJECTION		DRAWING SERIES D-SIZE 160027		