

THIS DRAWING IS UNPUBLISHED. RELEASED FOR PUBLICATION
 © COPYRIGHT - BY TYCO ELECTRONICS CORPORATION. ALL RIGHTS RESERVED.

LOC	DIST	REVISIONS					
		P	LTR	DESCRIPTION	DATE	DWN	APVD
AF	50		E1	ECR-06-023927(REDRAWN IN AUTOCAD)	17OCT06	HMR	GP

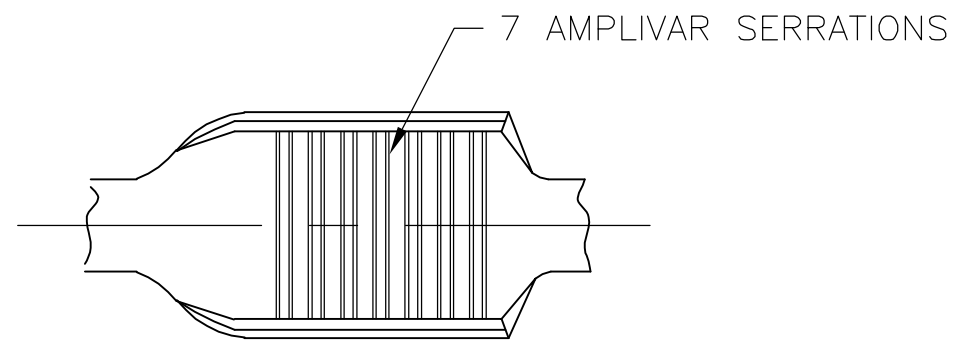

- CONTINUOUS STRIP ON REELS
- DIMENSIONS IN BRACKETS ARE IN INCHES
- FOR ADDITIONAL INFORMATION, SEE APPLICATION SPEC. 114-2002
- WIRE RANGE: 600-3000 CMA.
- CRIMP WIDTH: .110 F TYPE (AMPLIVAR PIGTAIL)
 CRIMP HEIGHT (±.002)=(TOTAL CMA+9,400)/190,500
 GENERAL APPLICATION GUIDELINES MUST BE FOLLOWED AS SPECIFIED IN CATALOG #82221
 FOR APPLICATOR INFORMATION CALL:1-800-722-1111
 FOR PRODUCT INFORMATION CALL:1-800-522-6752

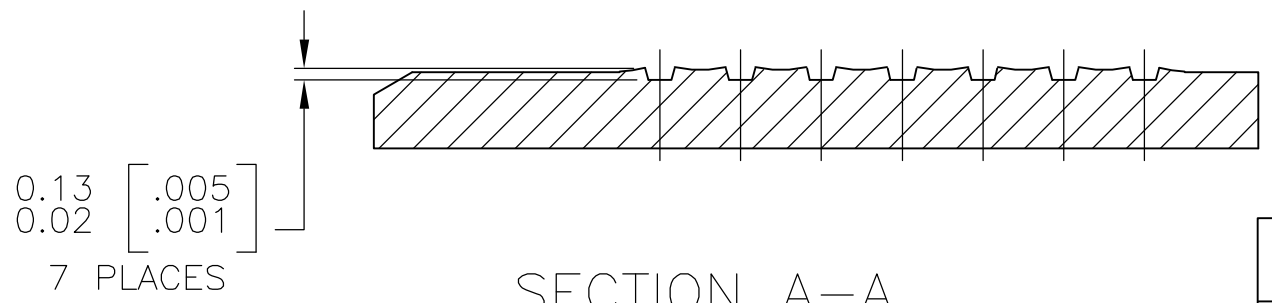
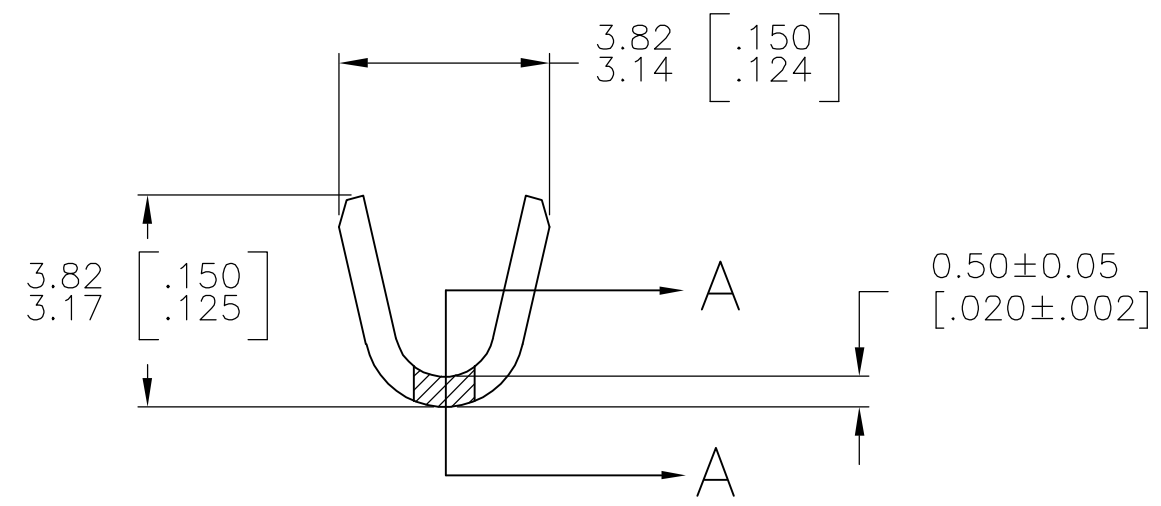
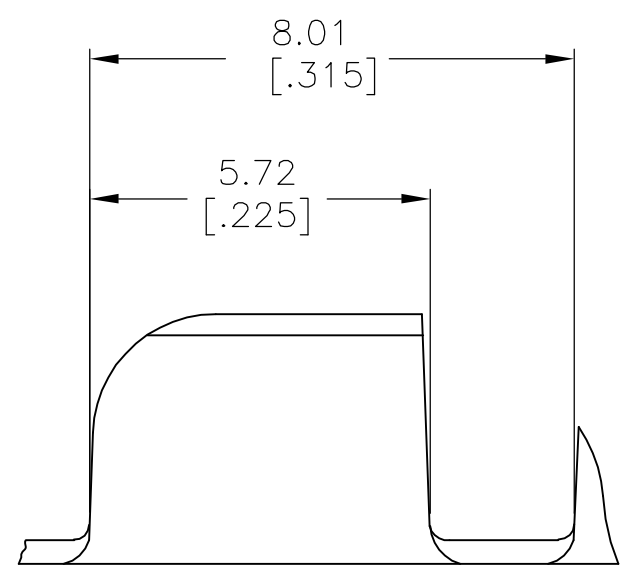

TIN PLATE	62157-2
-	62157-1
FINISH	PART NO

THIS DRAWING IS A CONTROLLED DOCUMENT.		DWN RAGHAVENDRA 17OCT2006	Tyco Electronics Corporation Harrisburg, PA 17105-3608	
DIMENSIONS: mm [INCHES]		CHK G.D.PORTA		
TOLERANCES UNLESS OTHERWISE SPECIFIED:		APVD G.D.PORTA	NAME	
0 PLC ± - 1 PLC ± - 2 PLC ± - 3 PLC ± 0.38 [.015] 4 PLC ± - ANGLES ± 1' 0"		PRODUCT SPEC -	SPLICE, AMPLIVAR	
MATERIAL BRASS		FINISH SEE TABLE	APPLICATION SPEC -	RESTRICTED TO -
		WEIGHT -	SIZE A3	CAGE CODE 00779
		CUSTOMER DRAWING	DRAWING NO C-62157	RESTRICTED TO -
		SCALE 8:1	SHEET 1 OF 1	REV E1