

SEE INTERFACE DRAWING(SEE CHART) FOR POCKET DETAILS
SEE NOTE 3.7

- NOTES: VALID UNLESS OTHERWISE SPECIFIED
- GENERAL:
 - APPLICATION SPECIFICATION 2005060000-AS
 - PRODUCT SPECIFICATION 2005060001-PS
CLASSIFICATIONS T1V1S1 TO GMW 3191 2012
 - PACKAGING SPECIFICATION PER MOLEX DRAWING
 - DESIGN - MATERIALS:
 - HOUSING: SPS 30% GF
 - BLADE TERMINALS:
 - 0.5MM BLADES
BASE MATERIAL: COPPER ALLOY
CONDUCTIVITY > 28% IACS @ 20°C
UNDERPLATE: OVERALL NICKEL
OVERPLATE: OVERALL TIN
 - 1.2MM BLADES
BASE MATERIAL: COPPER ALLOY
CONDUCTIVITY > 28% IACS @ 20°C
UNDERPLATE: OVERALL NICKEL
OVERPLATE: OVERALL TIN
 - 2.8MM BLADES
BASE MATERIAL: COPPER ALLOY
CONDUCTIVITY > 40% IACS @ 20°C
UNDERPLATE: OVERALL NICKEL
OVERPLATE: OVERALL TIN
 - FASTENER: STAINLESS STEEL
 - DESIGN - GEOMETRY:
 - ALL GRAPHIC DATA IS BASIC (NO TOLERANCE) AND MUST BE TAKEN FROM THE DATA FILE AT ITS LATEST REVISION
 - PRODUCT DESIGN MODEL NUMBER: SEE CHART. MODEL NUMBERS SAME AS PART NUMBERS.
 - GEOMETRIC DIMENSIONS AND TOLERANCES PER ASME Y14.5-2009
 - EDGES OF UNDEFINED SHAPE PER ISO 13715
 - CORNERS SHOWN AS SHARP TO BE R 0.4 MAX
 - LETTERING SHALL BE MAX POSSIBLE FOR READABILITY. THIS INCLUDES RECYCLING CODE, CAVITY ID, VENDOR IDENTIFICATION, AND CUSTOMER MATERIAL NUMBER.
 - FOR BAY/POCKET DEFINITION SEE MOLEX INTERFACE DRAWINGS IN CHART. FUNCTIONAL APPLIES TO ALL FUNCTIONALS IN INTERFACE DRAWINGS.
 - [G] DENOTES DIMENSIONS TO BE QUALIFIED WITH GAGE FOR PPAP AND IN PROCESS QUALITY CHECKS.
 - DESIGN - MANUFACTURING:
 - VISUAL DEFECTS SHALL MEET MOLEX COSMETIC STANDARD PS-45499-002 (CLASS B)
 - REFLOW SOLDERABILITY PER SMES-152
 - LASER ETCHED PART MARKING (1.5mm HEIGHT) CODED AS FOLLOWS
ROW 1: "YYDDHHMMSS"
- DATE AND TIME CODE
ROW 2: "XXXX" OR "XXXX_X"
- "XXXX" IS LAST 5 DIGITS OF PART NO AND DENOTES ORIGINAL ASSEMBLY LINE
- ".X" DENOTES CAPACITY ASSEMBLY LINE SUCH AS ".B" OR MORE IN FUTURE

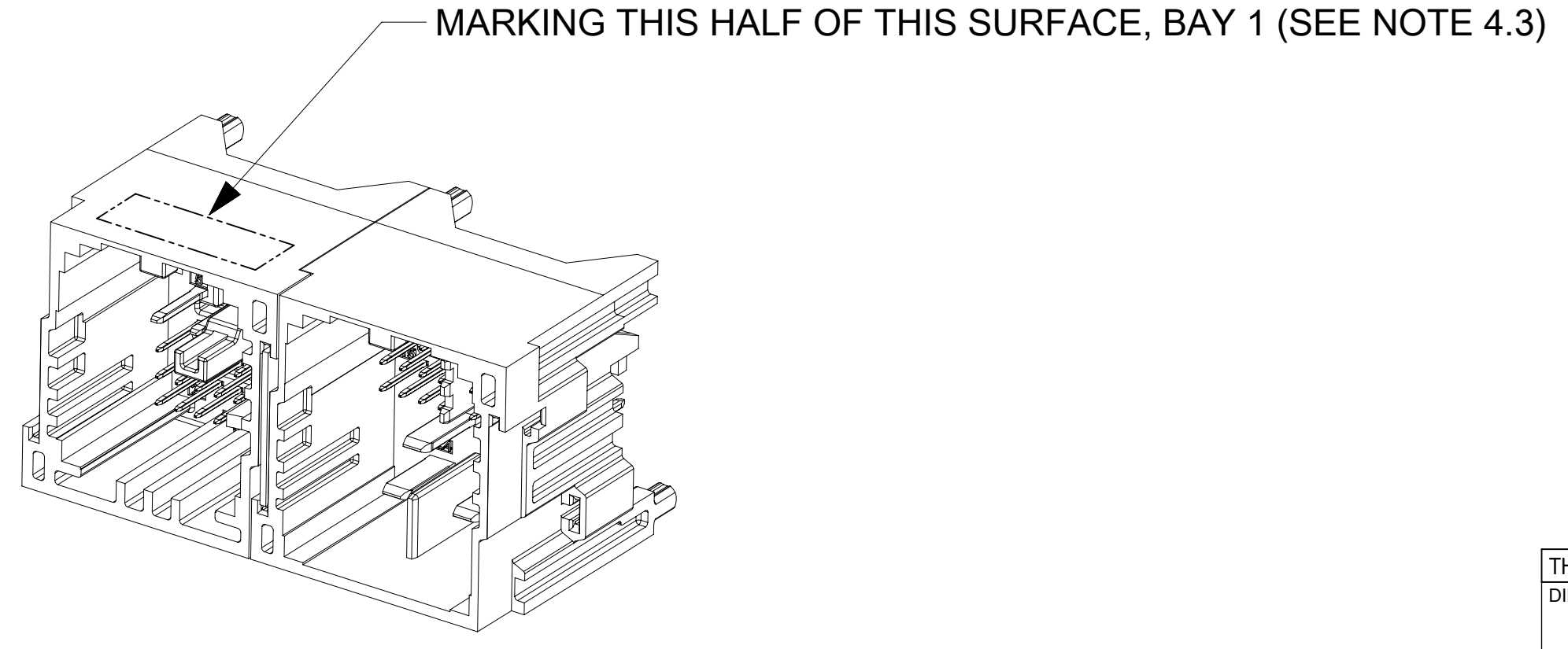

BAY QTY	DIM A
2	49.1
3	72.5
4	95.9
5	119.3
6	142.7
7	166.1

SEE SHEET 2	
REVISION	DESCRIPTION

THIS DRAWING CONTAINS INFORMATION THAT IS PROPRIETARY TO MOLEX ELECTRONIC TECHNOLOGIES, LLC AND SHOULD NOT BE USED WITHOUT WRITTEN PERMISSION

DIMENSION UNITS mm	SCALE 4:1	CURRENT REV DESC: SEE REVISION TABLE	
GENERAL TOLERANCES (UNLESS SPECIFIED)		EC NO: 684964	
ANGULAR TOL ± °		DRWN: RGV	2021/11/11
4 PLACES ± 0.0		CHK'D: JCONDON	2021/11/11
3 PLACES ± 0.0		APPR: JCONDON	2021/11/11
2 PLACES ± 0.13		INITIAL REVISION:	
1 PLACE ± 0.25		DRWN: JRUTTER	2016/05/04
0 PLACES ± 0.0		APPR: KDEKOSKI	2016/06/17
DRAFT WHERE APPLICABLE MUST REMAIN WITHIN DIMENSIONS	THIRD ANGLE PROJECTION	DRAWING	SERIES
		D-SIZE	200505
DOCUMENT NUMBER		MATERIAL NUMBER	CUSTOMER
2005050000		SEE CHART	
DOC TYPE	DOC PART	REVISION	
PSD	000	C11	
SHEET NUMBER			
1 OF 4			



INSPECTION BALLOON NUMBER LOG
PER DRAWING REVISION: C10
LAST BALLOON NUMBER: 17
ADDED BALLOON NUMBER: NONE
DELETED BALLOON NUMBER: NONE

ASSEMBLY PART NO.	SINGLE BAY ASSEMBLY PART NUMBER PER LOCATION							PACKAGING
	1	2	3	4	5	6	7	
2005052003	2005010281	2005010251	-----NA-----	-----NA-----	-----NA-----	-----NA-----	-----NA-----	TUBE
2005053001	2005010271	2005010272	2005010321	-----NA-----	-----NA-----	-----NA-----	-----NA-----	TUBE
2005054001	2005010251	2005010281	2005010321	2005010282	-----NA-----	-----NA-----	-----NA-----	TUBE
2005053002	2005010271	2005010273	2005010322	-----NA-----	-----NA-----	-----NA-----	-----NA-----	TUBE
2005053003	2005010252	2005010271	2005010322	-----NA-----	-----NA-----	-----NA-----	-----NA-----	TUBE
2005052004	2005010322	2005010122	-----NA-----	-----NA-----	-----NA-----	-----NA-----	-----NA-----	TUBE
2005053004	2005010122	2005010322	2005010324	-----NA-----	-----NA-----	-----NA-----	-----NA-----	TUBE
2005052007	2005010322	2005010324	-----NA-----	-----NA-----	-----NA-----	-----NA-----	-----NA-----	TUBE
2005053009	2005010121	2005010281	2005010251	-----NA-----	-----NA-----	-----NA-----	-----NA-----	TUBE
2005056001	2005010281	2005010322	2005010253	2005010122	2005010324	2005010273	-----NA-----	TUBE
2005053010	2005010321	2005010323	2005010324	-----NA-----	-----NA-----	-----NA-----	-----NA-----	TUBE
2005053011	2005010323	2005010324	2005010252	-----NA-----	-----NA-----	-----NA-----	-----NA-----	TUBE
2005054002	2005010321	2005010281	2005010251	2005010322	-----NA-----	-----NA-----	-----NA-----	TUBE
2005052005	2005010322	2005010122	-----NA-----	-----NA-----	-----NA-----	-----NA-----	-----NA-----	TRAY
2005052009	2005010251	2005010252	-----NA-----	-----NA-----	-----NA-----	-----NA-----	-----NA-----	TUBE
2005055004	2005010321	2005010322	2005010323	2005010324	2005010251	-----NA-----	-----NA-----	TUBE
2005052011	2005010252	2005010323	-----NA-----	-----NA-----	-----NA-----	-----NA-----	-----NA-----	TUBE
2005052012	2005010122	2005010322	-----NA-----	-----NA-----	-----NA-----	-----NA-----	-----NA-----	TUBE
2005053012	2005010324	2005010322	2005010122	-----NA-----	-----NA-----	-----NA-----	-----NA-----	TUBE
2005052013	2005010251	2005010271	-----NA-----	-----NA-----	-----NA-----	-----NA-----	-----NA-----	TUBE

SINGLE BAY ASSEMBLY	DRAWING	INTERFACE DRAWING	TERMINAL QUANTITIES		
			0.5mm	1.2mm	2.8mm
2005010121 THROUGH 2005010124	2005011120SD	SD-160026-002		8	4
2005010251 THROUGH 2005010254	2005011250SD	SD-160027-002	21		4
2005010271 THROUGH 2005010274	2005011270SD	SD-160029-002	19	8	
2005010281 THROUGH 2005010284	2005011280SD	SD-160014-002	21	7	
2005010321 THROUGH 2005010324	2005011320SD	SD-160028-002	28	4	

C11	ADDED PN 2005052013 11-NOV-2021, ECN: 684964
C10	NOTE 4.3 UPDATED
C9	CHANGE SINGLE BAY PN FROM 2005010322, 2005010322 TO 2005010122, 2005010322 FOR MULTI-BAY PN 2005052012
C8	ADDED PN 2005053012 21-APRIL-2021, ECN: 661591
C7	ADDED PN 2005052012 24-JULY-2020 MKP ECN:642177
C6	ADDED PCB HOLE DIMENSIONAL & POSITIONAL TOLERANCE 11-JUNE-2020 YPENG47 ECN:639277
C5	ADDED BALLOON #17 AND TOLERANCE ADDED PN 2005052011 ECN 638696
C4	ADDED PART NUMBER 2005055004 ECN 615503
C3	ADDED PART NUMBER 2005052009 ECN 610976
C2	ADDED PACKAGING COLUMN TO CHART
C1	ADDED NOTE 2.3. ADDED PART NUMBERS. ECN 602740.
C	INTERFACE GEOMETRY CHANGE TO LOCK TAB. SAP ECN 10906786.
B4	SWITCHED BAYS IN 2005052004 1MAY2018 ECN 10895975
B3	ADDED PART NUMBERS
B2	ADDED PART NUMBERS
B1	ADDED PART NUMBERS
B	PCB POST CHANGE, MODULE OPENING CHANGE, NOTES UPDATE
A2	ADDED PART NUMBERS, CHANGED MARKING. GDT ON MODULE OPENING.
A1	CHANGED 2005053003 25K2
A	RELEASE
1	INITIAL RELEASE
REVISION	DESCRIPTION

THIS DRAWING CONTAINS INFORMATION THAT IS PROPRIETARY TO MOLEX ELECTRONIC TECHNOLOGIES, LLC AND SHOULD NOT BE USED WITHOUT WRITTEN PERMISSION

DIMENSION UNITS mm	SCALE 1:1	CURRENT REV DESC: SEE REVISION TABLE				
GENERAL TOLERANCES (UNLESS SPECIFIED)						
ANGULAR TOL	± °	EC NO: 684964	STAK50H MODULAR HEADER VERT MULTIPLE BAY			
4 PLACES	± 0.0	DRWN: RGV 2021/11/11				
3 PLACES	± 0.0	CHK'D: JCONDON 2021/11/11	PRODUCT CUSTOMER DRAWING			
2 PLACES	± 0.13	APPR: JCONDON 2021/11/11				
1 PLACE	± 0.25	INITIAL REVISION:	DOCUMENT NUMBER	DOC TYPE	DOC PART	REVISION
0 PLACES	± 0.0	DRWN: JRUTTER 2016/05/04 APPR: KDEKOSKI 2016/06/17	2005050000	PSD	000	C11
DRAFT WHERE APPLICABLE MUST REMAIN WITHIN DIMENSIONS	THIRD ANGLE PROJECTION	DRAWING	MATERIAL NUMBER	CUSTOMER	SHEET NUMBER	
		D-SIZE	SERIES 200505	SEE CHART	2 OF 4	

RECOMMENDED PCB LAYOUT PER BAY FOR REFERENCE ONLY

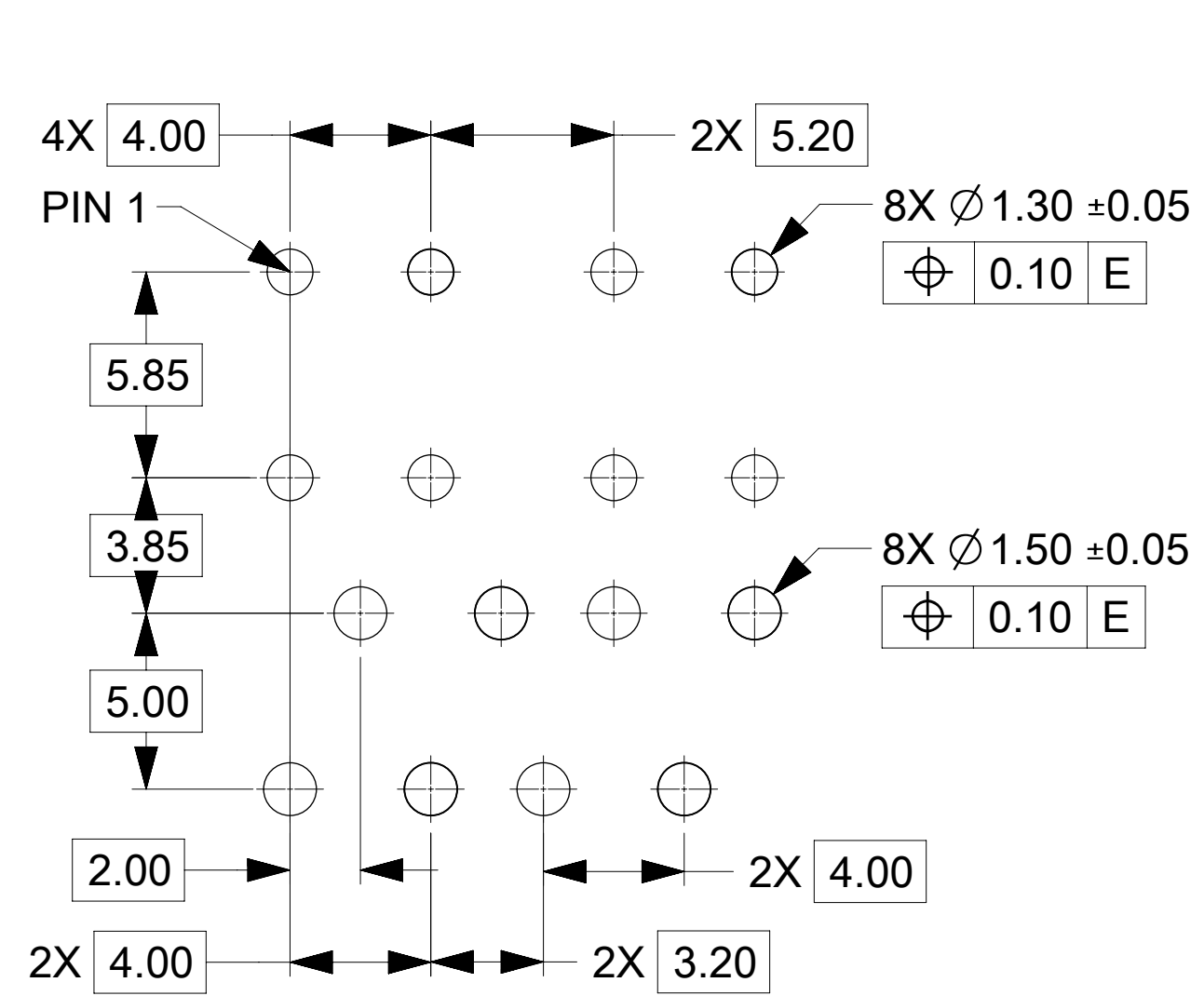

12 WAY
2005010121
2005010122
2005010123
2005010124

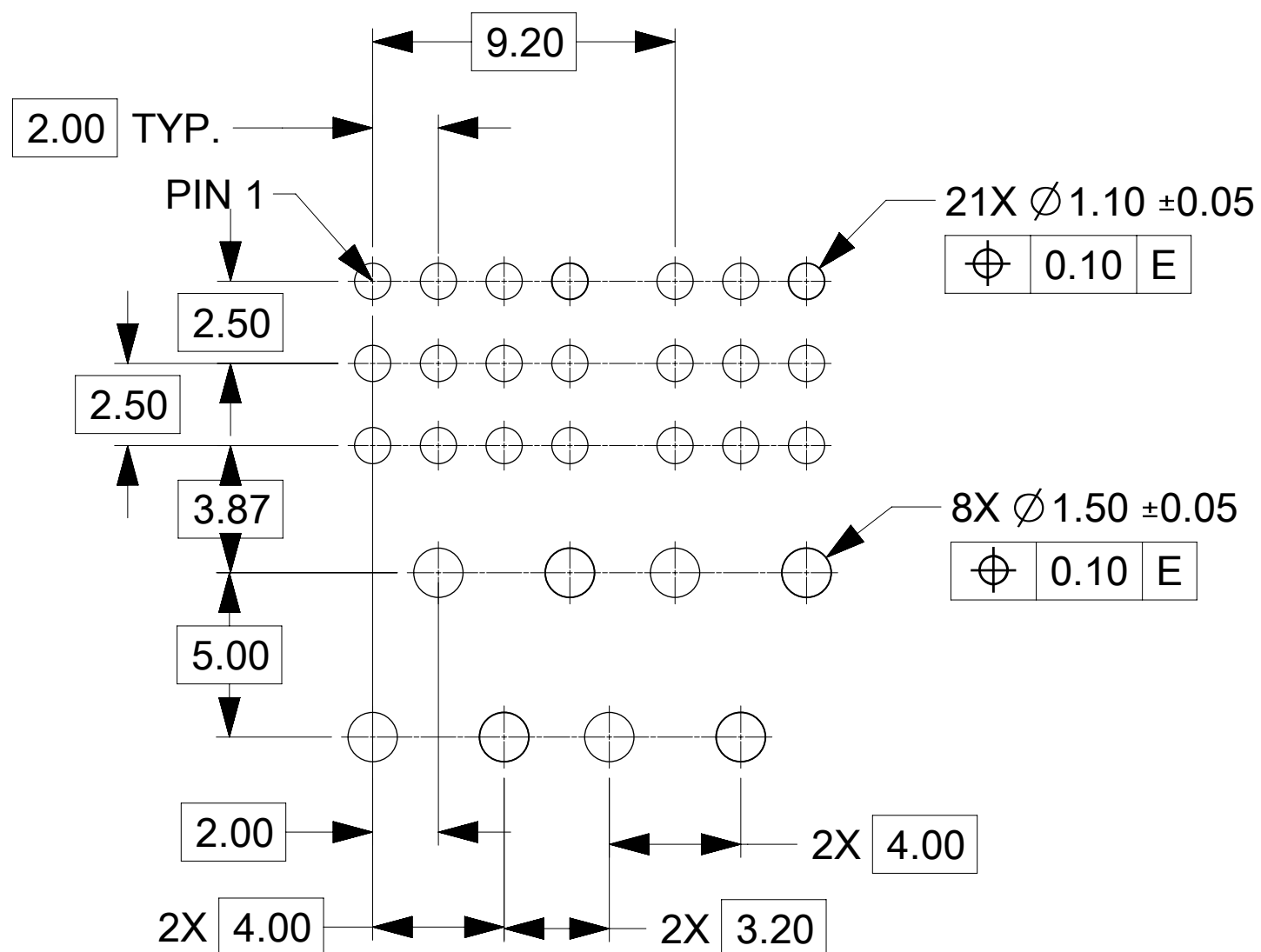

25 WAY
2005010251
2005010252
2005010253
2005010254

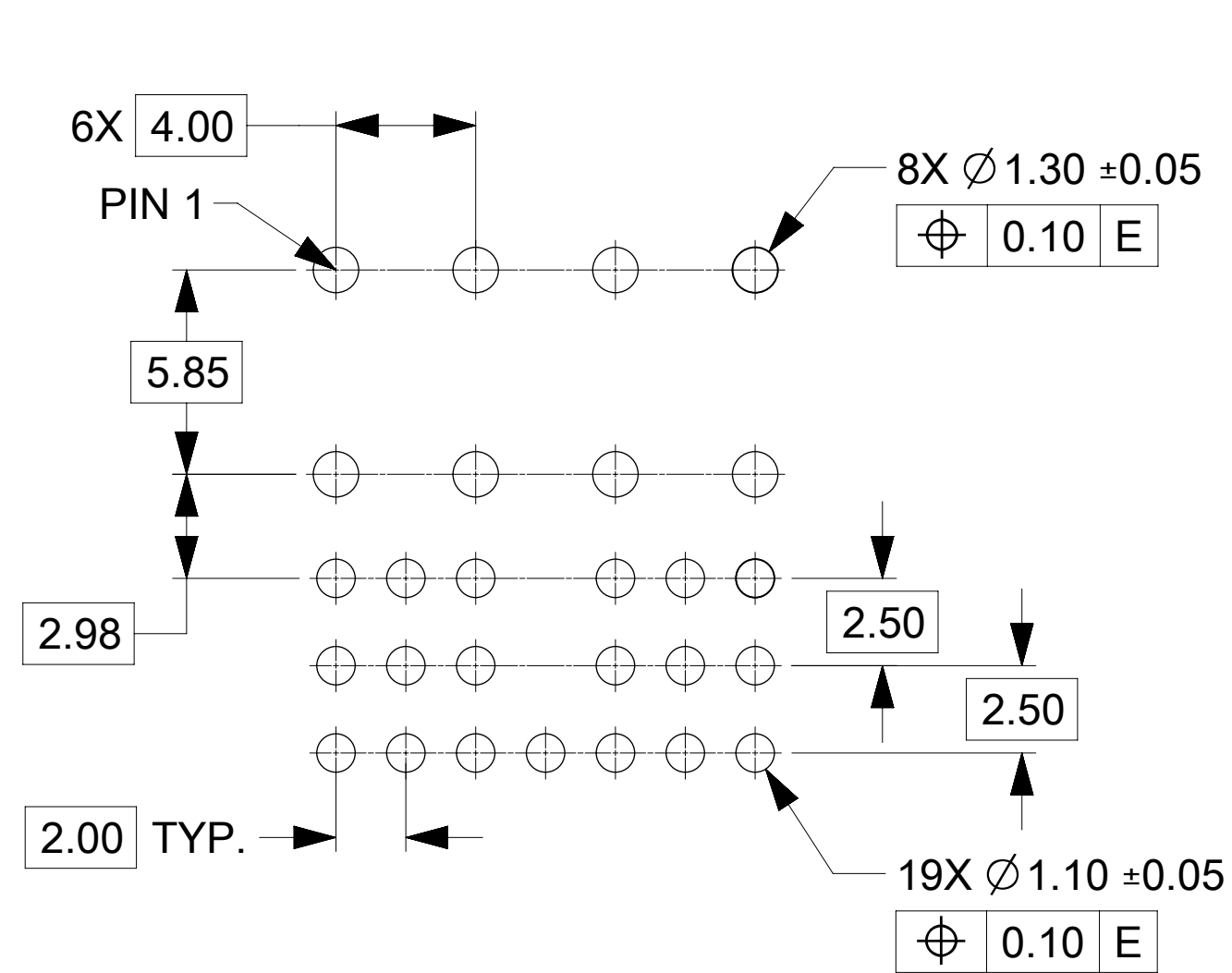

27 WAY
2005010271
2005010272
2005010273
2005010274

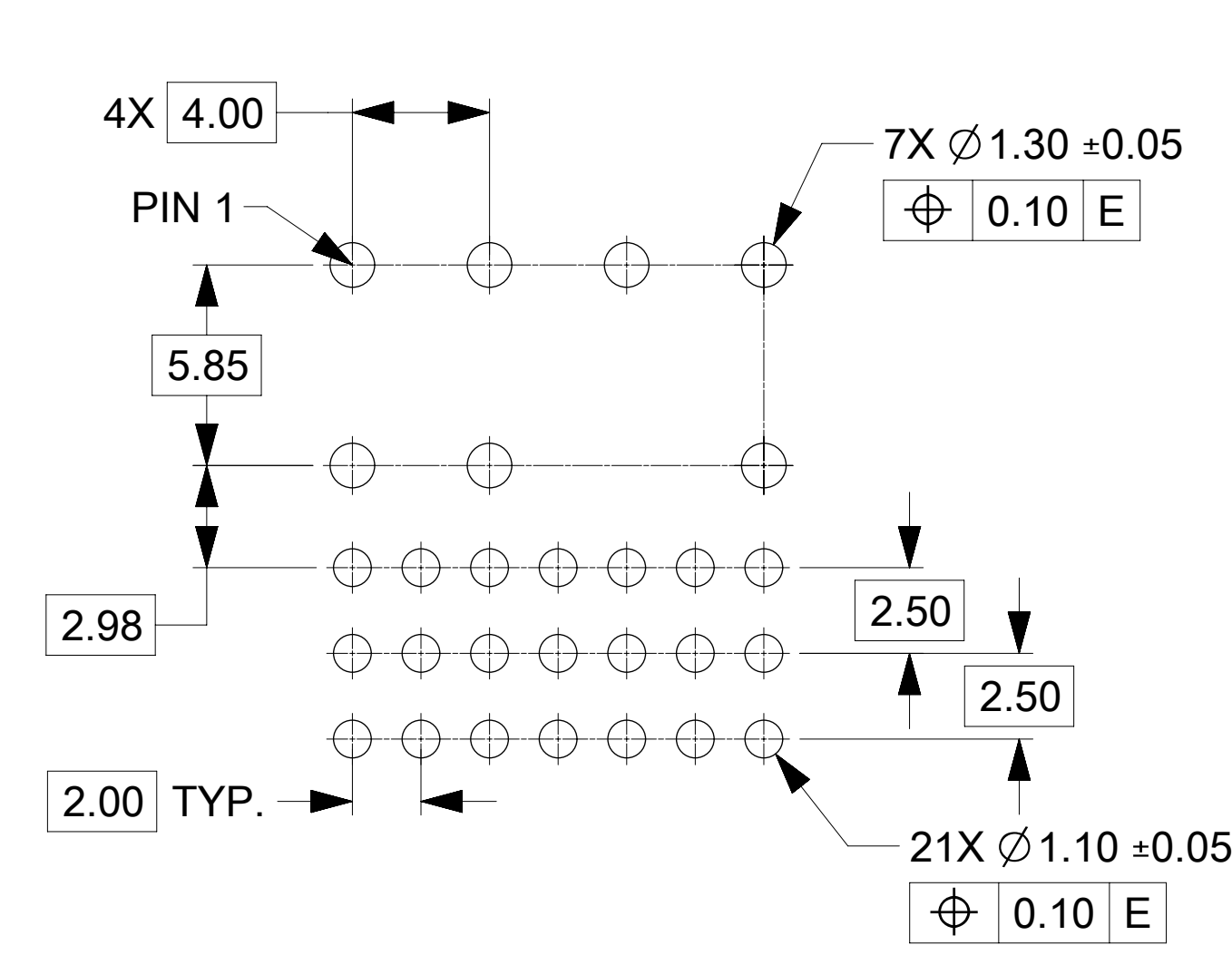

28 WAY
2005010281
2005010282
2005010283
2005010284

RECOMMENDED PCB LAYOUT FOR MULTIPLE BAY HEADER FOR REFERENCE ONLY INSERT NECESSARY BAYS USING CHART ON SHEET 1

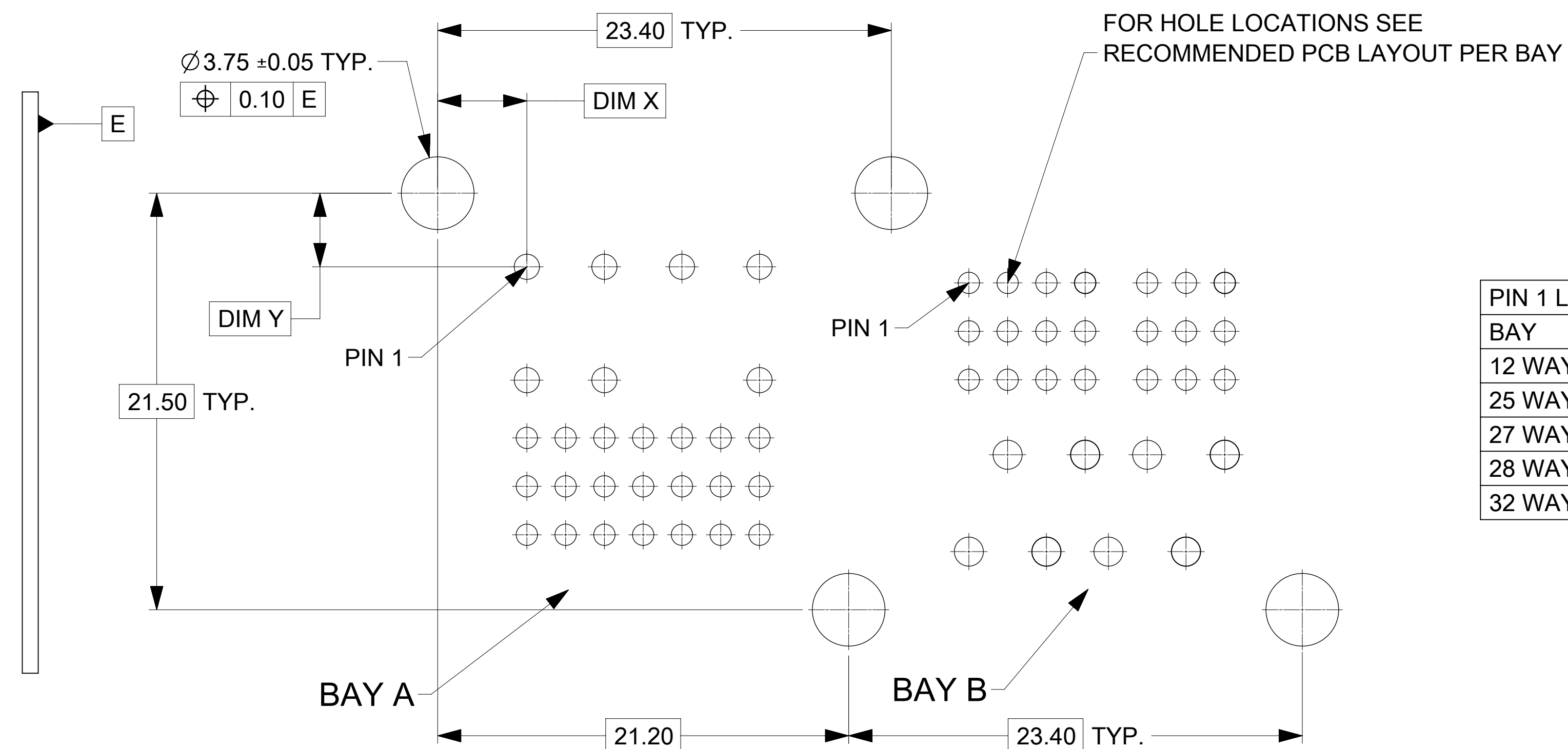

PIN 1 LOCATION CHART		
BAY	DIM X	DIM Y
12 WAY	4.0	3.8
25 WAY	4.0	4.63
27 WAY	4.6	3.8
28 WAY	4.6	3.8
32 WAY	4.0	3.8

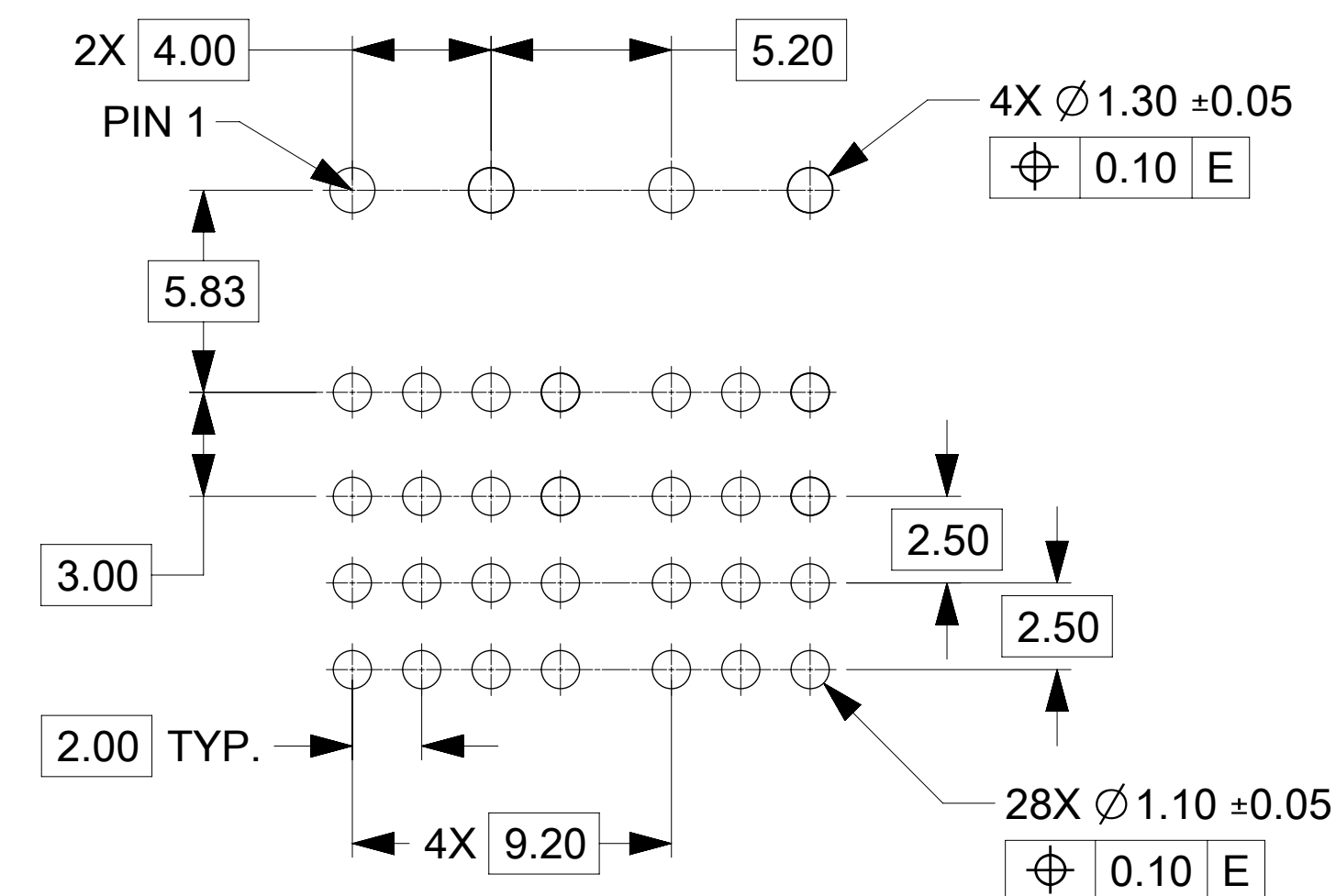

32 WAY
2005010321
2005010322
2005010323
2005010324

THIS DRAWING CONTAINS INFORMATION THAT IS PROPRIETARY TO MOLEX ELECTRONIC TECHNOLOGIES, LLC AND SHOULD NOT BE USED WITHOUT WRITTEN PERMISSION									
DIMENSION UNITS mm		SCALE 5:1		CURRENT REV DESC: SEE REVISION TABLE					
GENERAL TOLERANCES (UNLESS SPECIFIED)				 STAK50H MODULAR HEADER VERT MULTIPLE BAY PRODUCT CUSTOMER DRAWING					
ANGULAR TOL		± °							
4 PLACES		± 0.0							
3 PLACES		± 0.0							
2 PLACES		± 0.13							
1 PLACE		± 0.25		EC NO: 684964		DRWN: RGV		2021/11/11	
0 PLACES		± 0.0		CHK'D: JCONDON		APPR: JCONDON		2021/11/11	
DRAFT WHERE APPLICABLE MUST REMAIN WITHIN DIMENSIONS				THIRD ANGLE PROJECTION		INITIAL REVISION:		DOCUMENT NUMBER	
D-DRAWING		SERIES		2016/05/04		2016/06/17		2005050000	
D-SIZE		200505		MATERIAL NUMBER		CUSTOMER		PSD 000 C11	
SEE CHART		SEE CHART		SEE CHART		SEE CHART		SHEET NUMBER	
								3 OF 4	

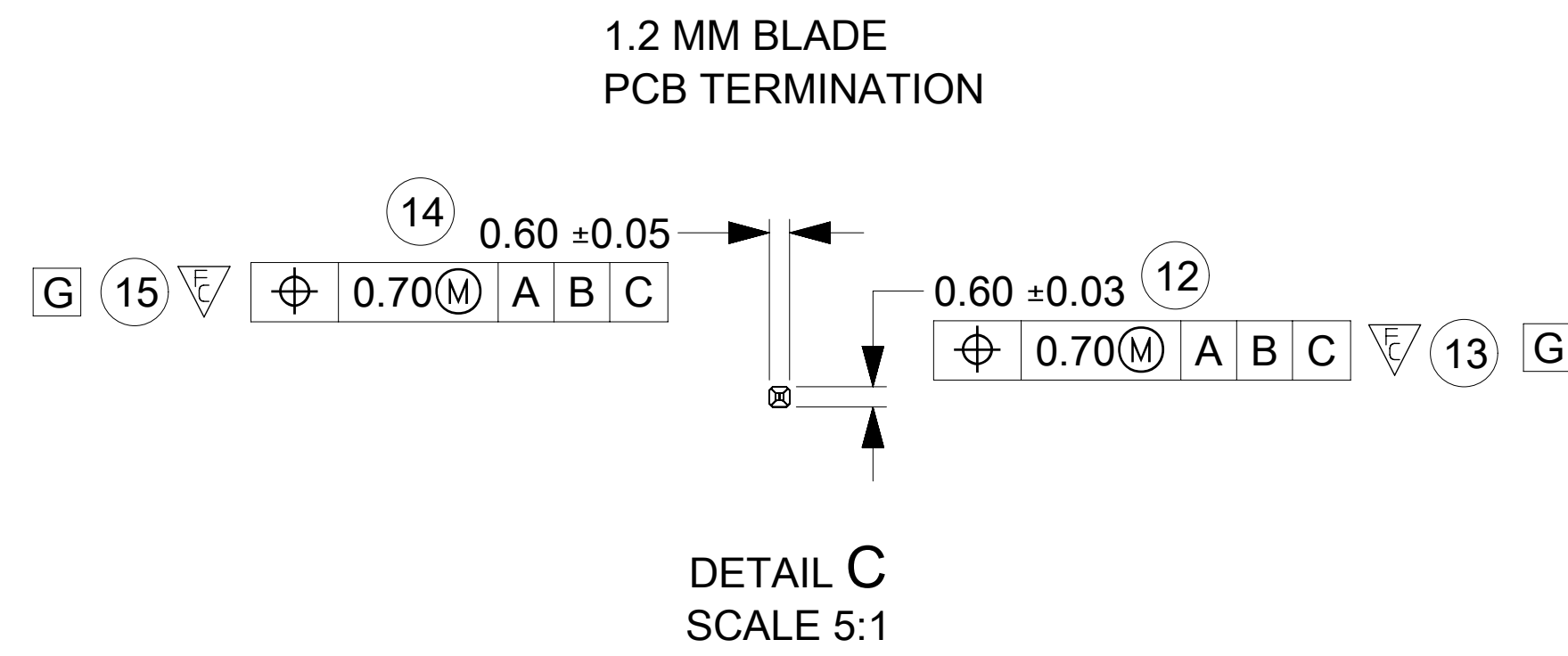
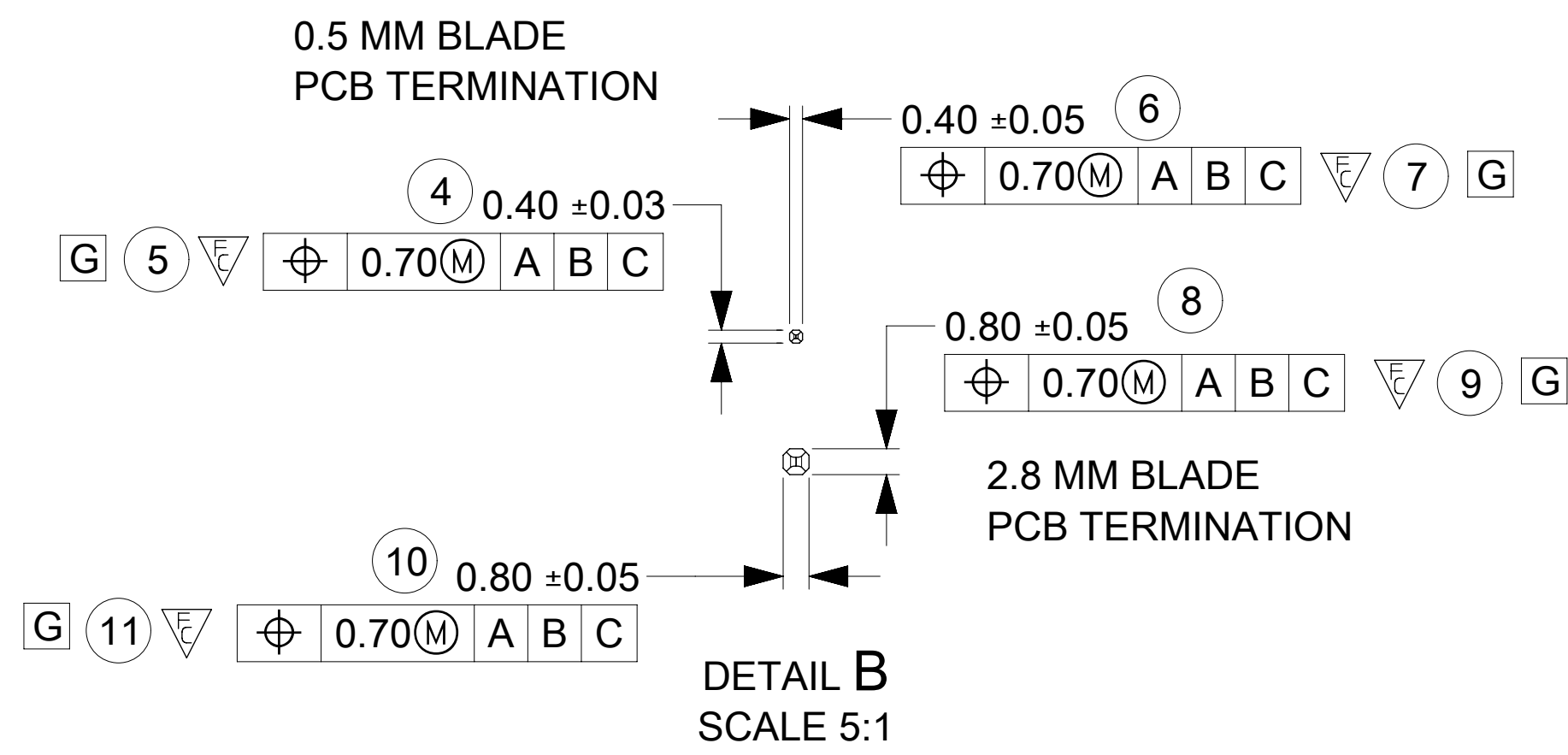

TYPICAL PCB TERMINATIONS
 SIZE AND TRUE POSITION TOLERANCES
 SEE INDIVIDUAL SINGLE BAY DRAWINGS FOR LOCATIONS (CHART ON SHEET 1)
 PARTS TO BE INSPECTED WITH FUNCTIONAL GAGE
 SEE NOTE 3.8

RECOMMENDED MODULE OPENING
 TO PASS ISO 20653 IP-4
 FOR INDIVIDUAL CONNECTOR IP RATINGS SEE PRODUCT SPECIFICATION IN NOTE 1.2

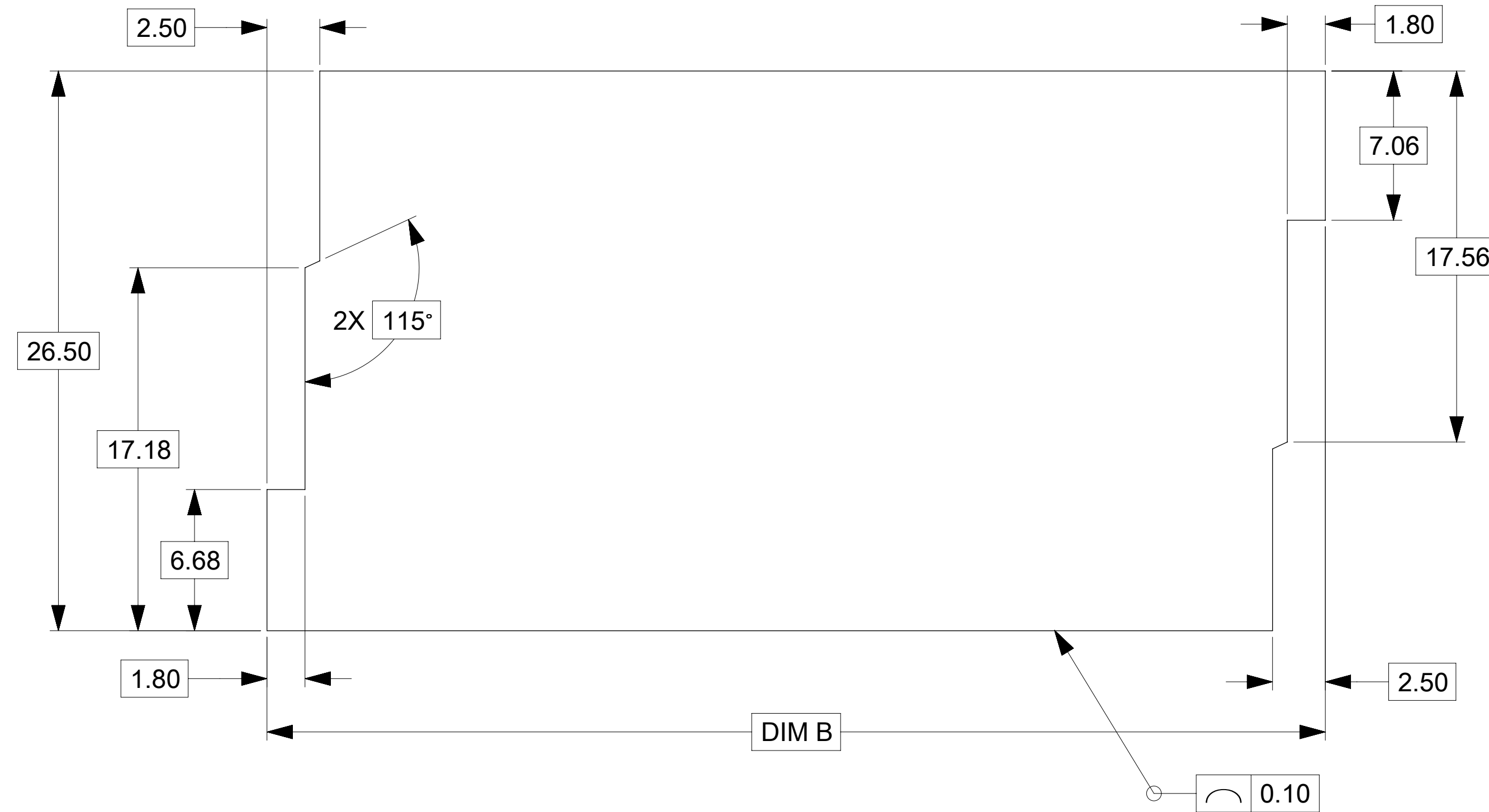

QTY BAYS	DIM B
2	50.1
3	73.5
4	96.9
5	120.3
6	143.7
7	167.1

FOR PACKAGE SPACE FOR CONNECTOR
 UNMATED AND MATED WITH COVER
 SEE INTERFACE DRAWINGS (CHART ON SHEET 1)

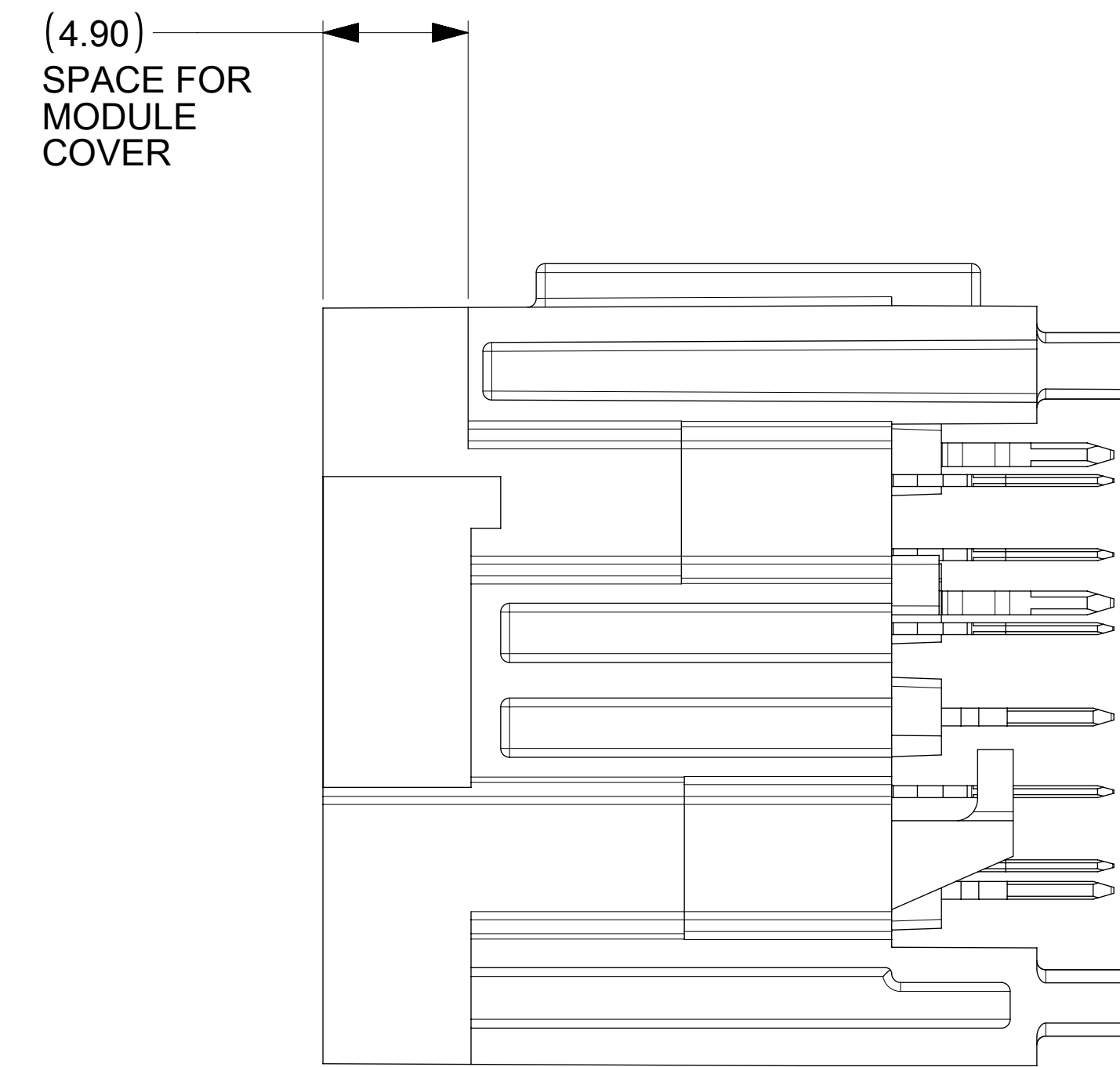

THIS DRAWING CONTAINS INFORMATION THAT IS PROPRIETARY TO MOLEX ELECTRONIC TECHNOLOGIES, LLC AND SHOULD NOT BE USED WITHOUT WRITTEN PERMISSION

DIMENSION UNITS mm	SCALE 5:1	CURRENT REV DESC: SEE REVISION TABLE	molex		
GENERAL TOLERANCES (UNLESS SPECIFIED)					
ANGULAR TOL	± °	EC NO: 684964	PRODUCT CUSTOMER DRAWING		
4 PLACES	± 0.0	DRWN: RGV 2021/11/11	DOCUMENT NUMBER		
3 PLACES	± 0.0	CHK'D: JCONDON 2021/11/11	2005050000		
2 PLACES	± 0.13	APPR: JCONDON 2021/11/11	DOC TYPE	DOC PART	REVISION
1 PLACE	± 0.25	INITIAL REVISION:	PSD	000	C11
0 PLACES	± 0.0	DRWN: JRUTTER 2016/05/04 APPR: KDEKOSKI 2016/06/17	SHEET NUMBER		
DRAFT WHERE APPLICABLE MUST REMAIN WITHIN DIMENSIONS	THIRD ANGLE PROJECTION	DRAWING D-SIZE	SERIES 200505	MATERIAL NUMBER SEE CHART	CUSTOMER