

**MALE FACE VIEW
4-POLE**

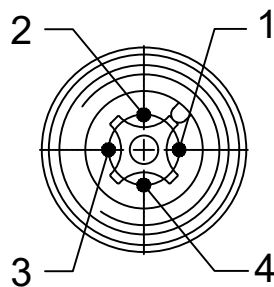

WIRING DIAGRAM

- 1 BROWN
- 2 WHITE
- 3 BLUE
- 4 BLACK

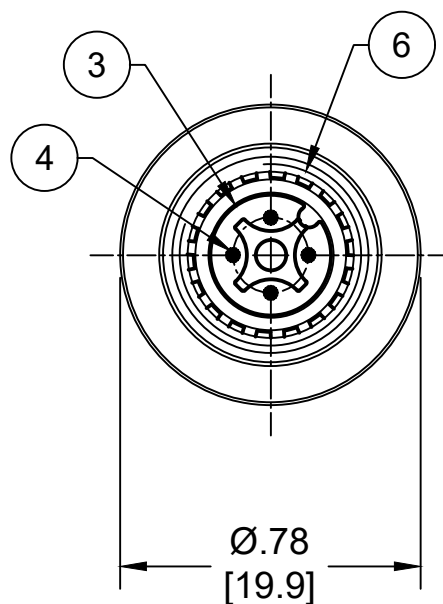

- NOTES:**
1. MATERIAL: AS NOTED
 2. FINISH: AS NOTED
 3. ELECTRICAL:
VOLTAGE: 250V
CURRENT: 4A
 4. TEMP RATING: -20°TO +105°C
 5. PROTECTION: IP67/69K (WHEN MATED)
 6. CSA CERTIFIED FILE: LR6837 (A)
 7. ALL DIMENSIONS ARE FOR REFERENCE
UNLESS TOLERANCED OR NOTED OTHERWISE

(A) PART NO	ENGINEERING NO.	FINISHED LENGTH
1200790107	W04006A09M020	2M [6FT 7 IN]
1200790105	W04006A09M050	5M [16FT 5 IN]
1200790103	W04006A09M100	10M [32FT 10 IN]

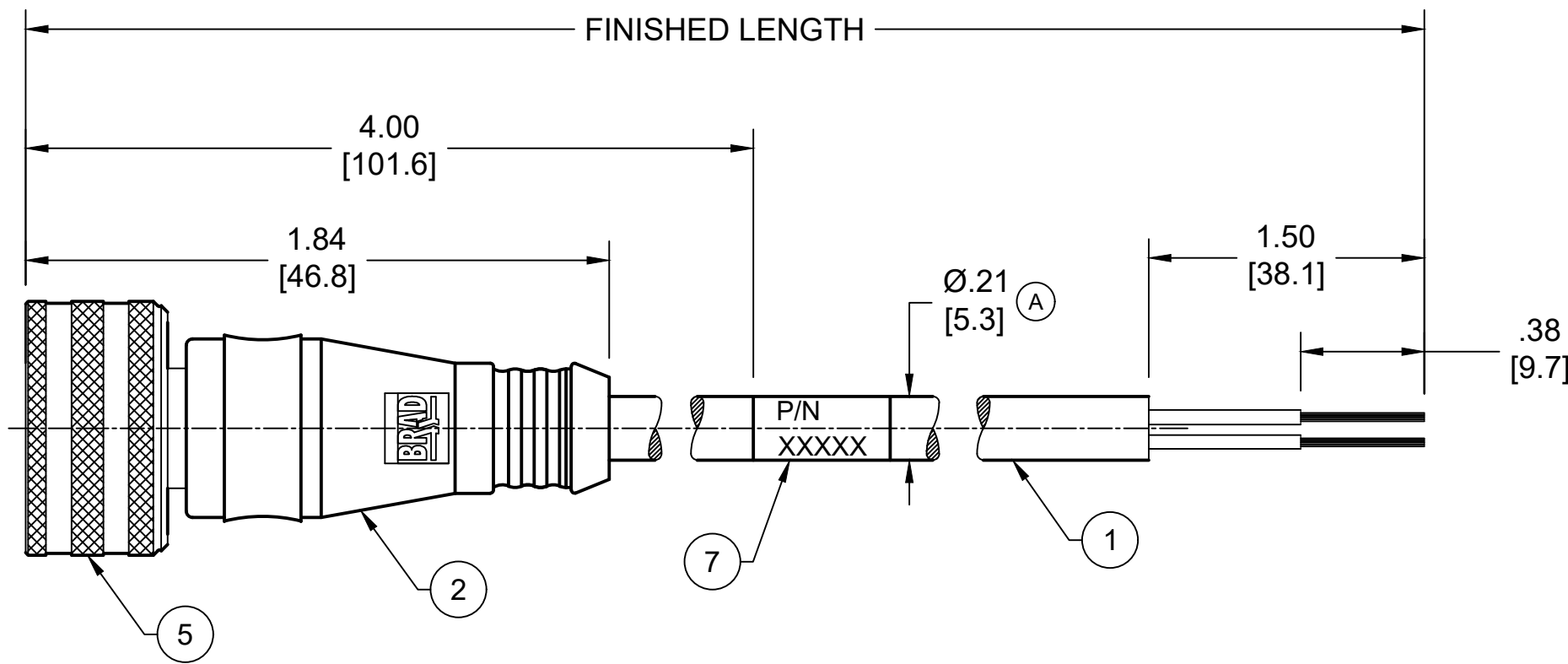

(A) **PART NUMBER LEGEND**
W04006A09M020

FINISHED LENGTH
M005 = 0.5 METER
M010 = 1 METER
M100 = 10 METER

(A) **CABLE LENGTH TOLERANCES**

<.3M [1FT]:	+19mm-0 [+ .75in-0]
.3 - .9M [1 - 3FT]:	+44.5mm-0 [+1.75in-0]
.9 - 1.8M [3 - 6FT]:	+55.6mm-0 [+2.19in-0]
1.8 - 3.7M [6 - 12FT]:	+88.9mm-0 [+3.50in-0]
3.7 - 7.3M [12 - 24FT]:	+165.1mm-0 [+6.50in-0]
7.3-14.6M [24 - 48FT]:	+317.5mm-0 [+12.50in-0]
14.6 - 30.5M [48-100FT]:	+622.3mm-0 [+24.50in-0]
OVER 30M [100FT]	+2% OF FINISHED LENGTH

ITEM	DESCRIPTION	MATERIAL	FINISH
7	WRAP LABEL	VINYL	BLACK/YELLOW (A)
6	O-RING	VITON	GREEN
5	COUPLER	BRASS	NICKEL PLATED
4	CONTACT PIN	COPPER ALLOY	GOLD OVER NICKEL
3	MALE INSERT	PUR	BLACK (A)
2	OVERMOLD	PUR	YELLOW
1	#22 AWG CABLE	PVC JACKET	YELLOW

FUNCTIONAL SYMBOLS $F_A=0$ $F_P=0$ $F_D=0$ DIVISIONAL SYMBOLS	THIS DRAWING CONTAINS INFORMATION THAT IS PROPRIETARY TO MOLEX ELECTRONIC TECHNOLOGIES, LLC AND SHOULD NOT BE USED WITHOUT WRITTEN PERMISSION		CURRENT REV DESC: ITEM #3 WAS NYLON & #7 WAS MYLAR. REMOVED UL. ADDED CSA, PN LEGEND & TOL CHART. MODIFIED CABLE DIA & PN TABLE.	
	DIMENSION UNITS	SCALE	EC NO: 702709	
	INCH/MM	NTS	DRWN: ABENJAMINLW	2021/07/22
	GENERAL TOLERANCES (UNLESS SPECIFIED)		CHK'D: RSTONE	2022/04/11
		APPR: BWOODMAN	2022/04/16	
		INITIAL REVISION:		
		DRWN: LSTEMMLE	2010/02/10	
		APPR: FPACHER	2010/02/15	
DRAFT WHERE APPLICABLE MUST REMAIN WITHIN DIMENSIONS		THIRD ANGLE PROJECTION	DRAWING	SERIES
		A3-SIZE	120079	MATERIAL NUMBER
		SEE CHART	GENERAL MARKET	CUSTOMER
				SHEET NUMBER
				1 OF 1