

APPROVED: \_\_\_\_\_  
 DATE: \_\_\_\_\_ TITLE: \_\_\_\_\_

Rev	AWO #	Description	Date	Appr
-		RELEASED	11/1/22	
A		UPDATE SPEC.	11/30/22	WX/RC

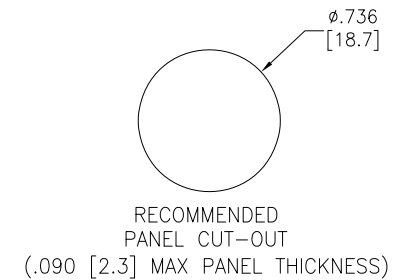
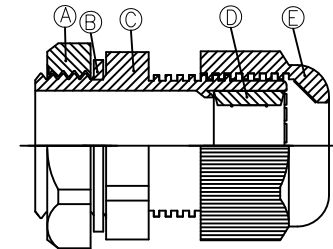
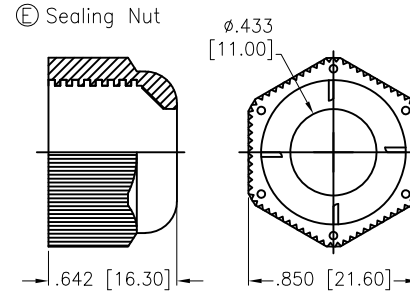
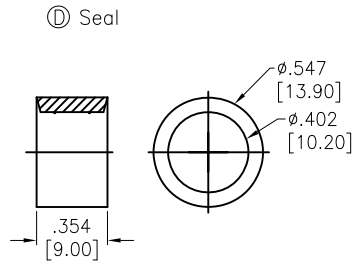
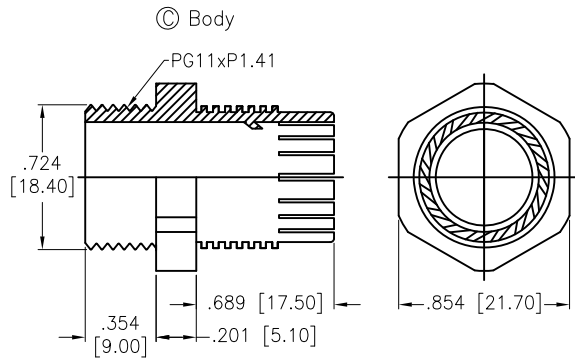
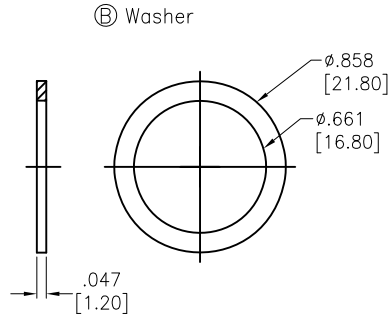
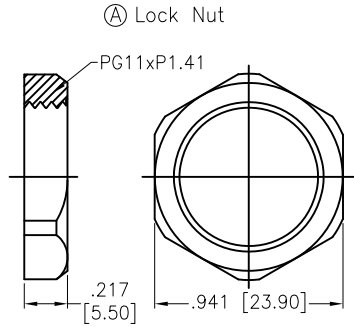

**SPECIFICATIONS:**

Material:  
 Lock Nut: PA66, rated UL 94V-2  
 Body: PA66, rated UL 94V-2  
 Sealing Nut: PA66, rated UL 94V-2  
 Washer: Nitrile Butylene  
 Seal: Nitrile Butylene  
 Mechanical:  
 Cable range O.D.:  $\phi 0.197 \sim \phi 0.394$  [5.00~10.00mm]  
 Nut Torque: 1.5Nm Max.  
 Environmental:  
 Waterproof: IP68  
 Lead free, RoHS compliant.



UNLESS OTHERWISE SPECIFIED ALL DIMENSIONS ARE INCHES [MM]. TOLERANCES: EXCEPT AS NOTED

INCHES		HOLES	
.X	$\pm .10$	$\phi X$	$\pm .10$
.XX	$\pm .020$	$\phi XX$	$\pm .015$
.XXX	$\pm .015$	$\phi XXX$	$\pm .010$



909 Rahway Avenue,  
 Union, NJ 07083  
 Phone: 908-687-5000  
 Fax: 908-687-5710

DRAWN	LH	11/1/22
CHECKED	RC	11/1/22
APPROVED		

TITLE WATERPROOF CONNECTOR, PG11, 1 HOLE, CABLE GLAND, WATERPROOF: IP68

THIS DRAWING CONTAINS INFORMATION THAT IS PROPRIETARY AND SHOULD NOT BE USED WITHOUT PRIOR WRITTEN PERMISSION FROM ADAM TECH

SIZE X	PART NO. CG-P-11	REV. A
REF: S00211C	SCALE: NTS	SHEET 1 OF 1