

PART NUMBER	REVISION	DESCRIPTION	FEED TYPE
2150308-1	C	FINE CRIMP HEIGHT ADJUST	MECHANICAL
2150308-2	C	FINE CRIMP HEIGHT ADJUST	PNEUMATIC
7-2150308-1	C	MECHANICAL AND CRIMP TOOLING KIT	MECHANICAL
7-2150308-2	C	PNEUMATIC AND CRIMP TOOLING KIT	PNEUMATIC
7-2150308-7	A	CRIMP TOOLING KIT	-

ATLANTIC VERSION TERMINATOR INTERFACE ADAPTER



APPLICATOR DATA		
CRIMP	SIZE	TYPE
WIRE	3.05 mm [.120]	F
INSUL	3.94 mm [.155]	F

APPLICATOR INSTRUCTIONS 408-35043

TERMINAL DATA: TE TERMINAL		TE CRIMP SPECIFICATION	
TERMINAL NAME: .187 SR. FASTIN-FASTON REC. TERM.			
WIRE STRIP LENGTH		INSULATION DIAMETER RANGE	
3.75-4.51 mm [.148-.178 IN]		Ø3.00-4.30 mm [.118-.169 IN]	
TERMINAL APPLICATION SPECIFICATION	114-20011	-	-
TERMINALS APPLIED			
TE TERMINAL	TE TERMINAL	TE TERMINAL	TE TERMINAL
281197-2			

TERMINAL DATA: TE TERMINAL		TE CRIMP SPECIFICATION	
TERMINAL NAME: .187 SR. FASTIN-FASTON REC. TERM.			
WIRE STRIP LENGTH		INSULATION DIAMETER RANGE	
3.75-4.51 mm [.148-.178 IN]		Ø3.00-4.30 mm [.118-.169 IN]	
TERMINAL APPLICATION SPECIFICATION		-	-
TERMINALS APPLIED			
TE TERMINAL	TE TERMINAL	TE TERMINAL	TE TERMINAL
281197-2			

WIRE SIZE	CRIMP HEIGHT mm [INCH]	CRIMP HEIGHT REFERENCE SETTING
2.50mm2	1.57+/-0.03 [.062+/- .001]	2.1
1.50mm2	1.37+/-0.03 [.054+/- .001]	4.0
1.00mm2	1.27+/-0.03 [.050+/- .001]	5.1

WIRE SIZE	CRIMP HEIGHT mm [INCH]	CRIMP HEIGHT REFERENCE SETTING
1.50+0.50mm	1.57+/-0.03 [.062+/- .001]	2.1
14 AWG	1.50+/-0.03 [.059+/- .001]	2.8

- 1 RECOMMENDED SPARE PARTS
- 2 REFER TO SUPPLIED INSTRUCTION SHEET FOR CLEANING, LUBRICATION AND STORAGE OF APPLICATOR.
- 3 APPLY PART NUMBER 2-23419-6 LOCTITE TO THREADS OF ITEM 242.
- 4 CRIMP HEIGHT REFERENCE SETTING WAS THE SETTING USED WHEN THE APPLICATOR WAS QUALIFIED AT THE FACTORY. ADJUSTMENT MAY BE NECESSARY WHEN RUNNING APPLICATOR IN THE FIELD.
- 5. UNLESS SPECIFIED OTHERWISE TORQUE VALUES SHALL BE USED PER DOCUMENT, 101-35000.
- 6 THIS CRIMP PARAMETER IS PROVIDED TO MEET A CUSTOM AND UNIQUE CUSTOMER REQUIREMENT. IT HAS BEEN EVALUATED AND IS CONDITIONALLY SPECIFIED BY TE CONNECTIVITY. THIS CUSTOMIZED CRIMP PARAMETER IS NOT LISTED AS AN APPROVED APPLICATION WITHIN A TE CONNECTIVITY APPLICATION SPECIFICATION; HOWEVER, IT HAS BEEN VALIDATED ACCORDING TO TE CONNECTIVITY SPECIFICATIONS 109-18079 (TEST GROUP 1) AND 114-18022. TE CONNECTIVITY EXPRESSLY DISCLAIMS ANY AND ALL WARRANTIES THAT THE PRODUCT WILL PERFORM SIMILARLY TO VALIDATED AND APPROVED APPLICATIONS, AS STATED WITHIN TE CONNECTIVITY APPLICATION SPECIFICATIONS, INCLUDING BUT NOT LIMITED TO IMPLIED WARRANTIES OF MERCHANTABILITY OR FITNESS FOR PARTICULAR PURPOSE. AS SUCH, IT IS HIGHLY RECOMMENDED THAT THE CUSTOMER PERFORM FURTHER DETAILED EVALUATION TO ASSESS PRODUCT PERFORMANCE IN THE SPECIFIC APPLICATION.

***WARNING**
ON INSTALLATION, SET WIRE DISC TO CRIMP HEIGHT REFERENCE SETTING FOR LARGEST WIRE SIZE. CRIMP HEIGHT REFERENCE SETTINGS GREATER THAN THE VALUE SHOWN MAY CAUSE DAMAGE TO THE CRIMP TOOLING. REFER TO THE INSTRUCTION SHEET FOR PROPER SETUP AND ADJUSTMENTS.

ATLANTIC VERSION
Shown on sheets 1 of 4 & 2 of 4
(Pacific version shown on sheets 3 of 4 & 4 of 4)

LOC	DIST	REVISIONS					
A	66	P	LTN	DESCRIPTION	DATE	DWN	APVD
		B1		ECR-15-011007	23JUL2015	MR	JDG
		B2		ECR-17-011347	04AUG2017	MZ	KZ
		C		ECR-19-005157	31MAR2019	TB	CT

-	1	-	1	-	2119640-1	PUSH ROD, AIR FEED	250	
-	1	-	1	-	1803259-1	BUSHING, FLANGED	249	
-	1	-	1	-	2119641-1	FEED CAM, AIR FEED	248	
-	1	1	1	1	2119082-9	CAM, SNAIL, INSULATION ADJUSTMENT	244	
-	1	1	1	1	2079764-1	WASHER, WAVE SPRING, CREST-TO-CREST	243	
-	1	1	1	1	2119083-1	RETAINER, INSULATION DIAL	242	
-	-	1	-	1	2119580-1	MECHANICAL FEED ASSEMBLY	239	
-	1	-	1	-	2063440-1	AIR FEED MODULE	238	
-	1	1	1	1	1-18028-0	WASHER, FLAT, REG M8	192	
-	2	-	2	-	21045-3	RING, RETAIN, EXTERN, 3/16 CRESCENT	172	
-	REF	REF	REF	REF	994970-2	COUNTER, MAGNETIC	164	
-	1	-	1	-	240638-1	SPRING, FEED FINGER	163	
-	1	-	1	-	3-23627-7	PIN, RETAIN, GRVD, 3/16 X .854	137	
-	1	1	1	1	1-455888-0	SPACER, CRIMPER	82	
-	1	1	1	1	2119791-9	DEPRESSOR, WIRE	73	
-	1	1	1	1	1803607-2	DOCUMENTATION PACKAGE	71	
-	2	2	2	2	2-18032-2	SCR, SET, FLT PNT, M3 X 10.0	70	
-	1	1	1	1	2119943-1	WASHER, SPACER	69	
-	1	1	1	1	2119740-1	TAG, IDENTIFICATION	67	
-	2	2	2	2	2168078-1	SCREW, DRIVE, RH, RoHS, 2 x .188	66	
-	2	2	2	2	2168400-5	SHCS, LOW HEAD, RoHS, M4 X 20	64	
-	1	1	1	1	2168083-2	SCR, SKT HD CAP, RoHS, M4 X 8.0	60	
-	-	1	-	1	5-18022-5	SCR, HEX HD CAP, M4 X 6.0	59	
-	-	1	-	1	2063961-1	FEED FINGER	58	
-	3	3	3	3	2168400-4	SHCS, LOW HEAD, RoHS, M4 X 8	57	
-	2	2	2	2	2168083-2	SCR, SKT HD CAP, RoHS, M4 X 8.0	56	
-	2	2	2	2	5018030-1	NUT, HEX, REG, RoHS, M3	54	
-	2	2	2	2	986965-8	NUT, LOCK, HEX, TORQUE (M4)	53	
-	1	-	1	-	2119792-2	PAWL, EF, AIR	51	
-	1	2	1	2	18023-9	SCR, SKT HD CAP M4 X 6.0	49	
-	-	1	-	1	2119652-1	FEED CAM, PRE FEED	48	
-	-	1	-	1	2119653-1	FEED CAM, POST FEED	47	
-	1	1	1	1	2119655-5	APPLICATOR BASIC ASSEMBLY, EF	46	
-	1	1	1	1	1803517-1	RAM ASSEMBLY, EF ATLANTIC	44	
-	1	1	1	1	1803602-1	SCR, BHSC, RoHS (M8 X 25)	41	
-	7	7	7	7	1-18028-2	WASHER, FLAT, REG M4	33	
-	2	2	2	2	2168083-9	SCR, SKT HD CAP, RoHS, M4 X 20	31	
-	2	2	2	2	2168083-2	SCR, SKT HD CAP, RoHS, M4 X 8.0	29	
-	1	1	1	1	240639-4	STRIPPER (MACHINING)	27	
-	2	2	2	2	1-2168083-5	SCR, SKT HD CAP, RoHS, M4 X 30	25	
-	1	1	1	1	1752371-9	PLATE, STRIP GUIDE	24	
-	1	1	1	1	240825-2	PLATE, STRIP HOLD DOWN	23	
-	2	2	2	2	2-22281-3	SPRING, COMPRESSION	22	
-	1	1	1	1	1803292-4	DRAG	20	
-	2	2	2	2	1901259-5	GUIDE, LOWER STRIP	18	
-	4	4	4	4	1-2079383-1	SCR, BHSC, RoHS (M6 X 12)	17	
-	1	1	1	1	240833-3	PLATE, REAR SHEAR	11	
-	-	-	-	-	-	-	10	
-	1	1	1	1	690496-7	PLATE, FRONT SHEAR	9	
-	1	2	2	1	1333220-1	ANVIL, COMBINATION, .120	8	
-	1	1	1	1	2217206-4	BLADE, SLUG	7	
-	-	-	-	-	-	-	6	
-	1	1	1	1	240641-2	SPACER	5	
-	1	1	1	1	238011-2	BLOCK, CRIMPER SPACER	4	
-	1	2	2	1	3-2119582-6	CRIMPER, INSULATION F PREMIUM	3	
-	-	-	-	-	-	-	2	
-	1	2	2	1	456409-1	CRIMPER, WIRE .120 "F" PREMIUM	1	
-	77	72	71	2	-1	PART NO	DESCRIPTION	ITEM NO

DIMENSIONS:		TOLERANCES UNLESS OTHERWISE SPECIFIED:		DWN		CHK		APVD		NAME	
mm	0 PLC ±	1 PLC ±	2 PLC ±	3 PLC ±	4 PLC ±	09JAN2013	L. ZHANG	09JAN2013	L. ZHANG	09JAN2013	TE Connectivity Harrisburg, PA 17105-3608
		ANGLES ±		FINISH ±		PRODUCT SPEC		APPLICATION SPEC		SIZE CAGE CODE DRAWING NO RESTRICTED TO	
MATERIAL		FINISH		WEIGHT		A1 00779		C=2150308		CUSTOMER ACCESSIBLE PRODUCTION DRAWING SCALE 1:1 SHEET 1 OF 4 REV C	

LOC		DIST		REVISIONS			
A	66	P	LTM	DESCRIPTION	DATE	OWN	APVD
		-		SEE SHEET 1	-	-	-

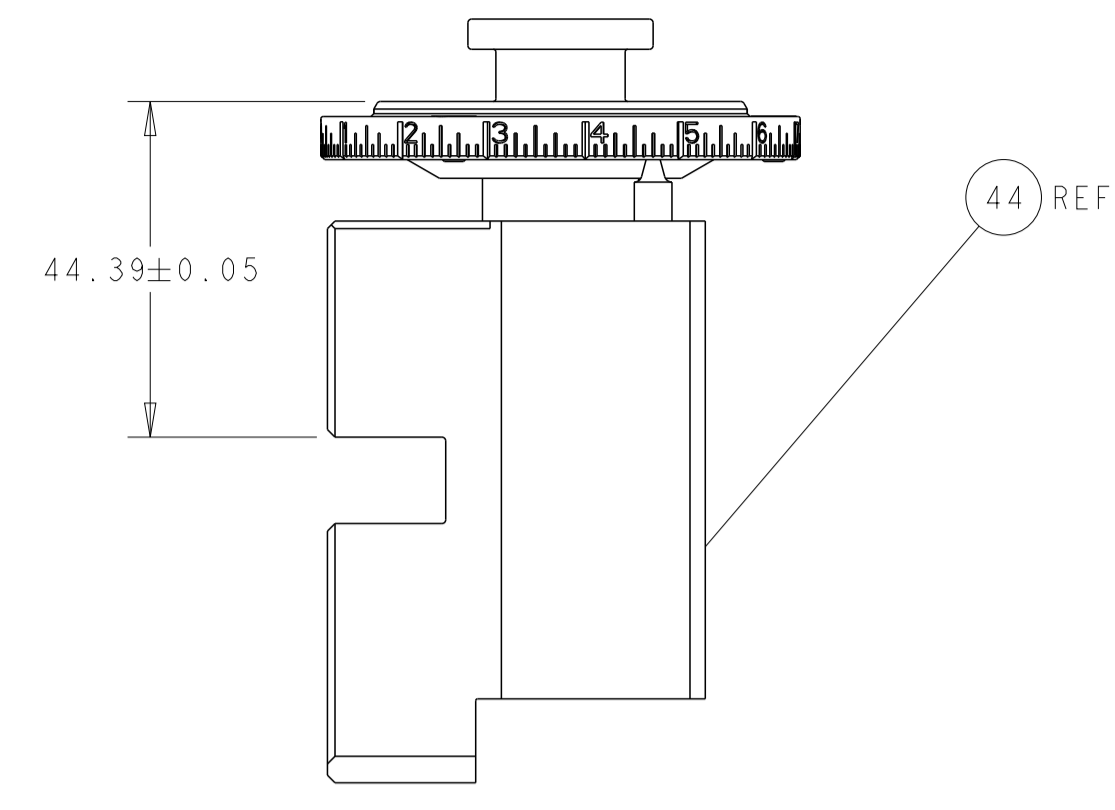

RAM SET-UP

FEED TYPE
MECHANICAL

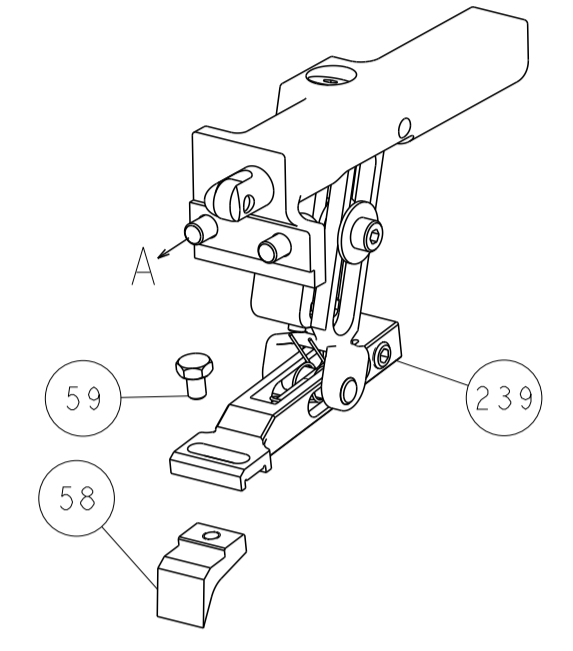

PNEUMATIC

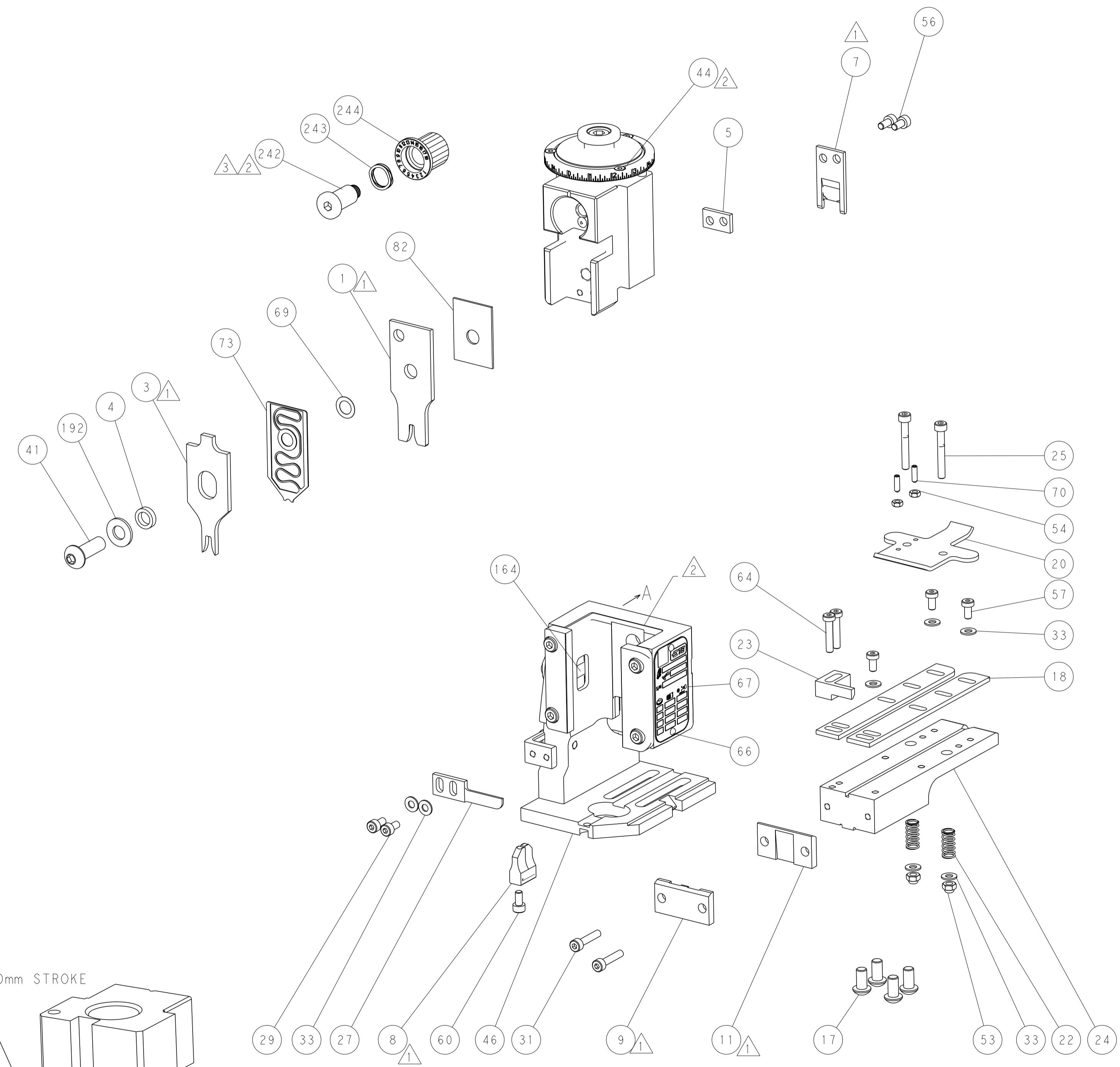
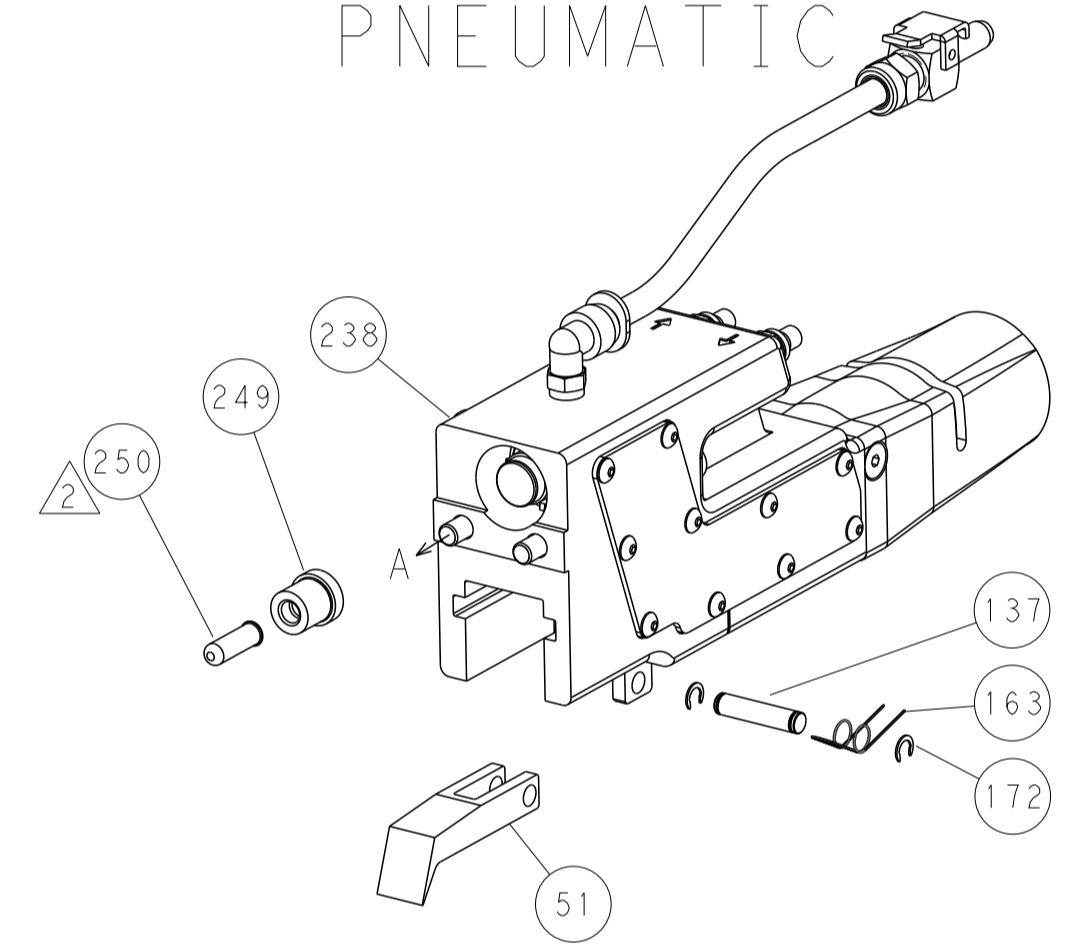

CAM POSITIONS

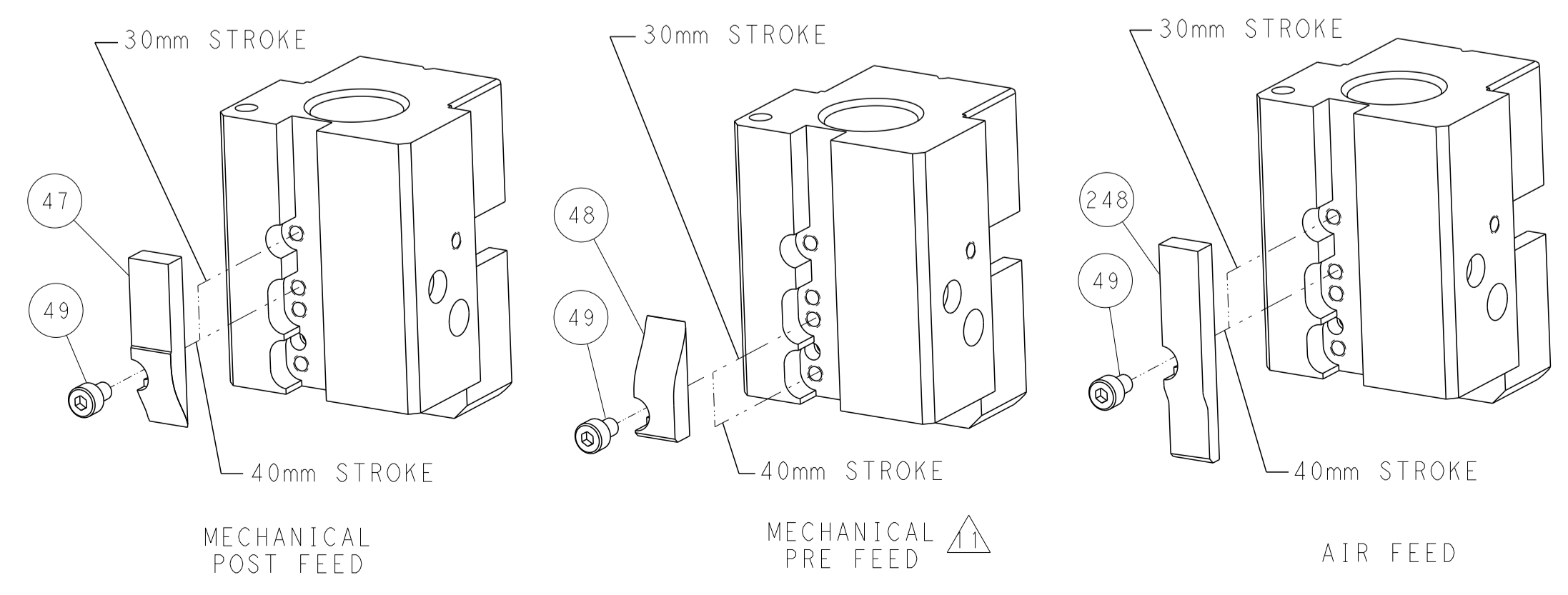

ATLANTIC VERSION
 Shown on sheets 1 of 4 & 2 of 4
 (Pacific version shown on sheets 3 of 4 & 4 of 4)

DIMENSIONS: mm 		TOLERANCES UNLESS OTHERWISE SPECIFIED: 0 PLC ± 1 PLC ± 2 PLC ± 3 PLC ± 4 PLC ± ANGLES ° ± FINISH		DWN L. ZHANG 09JAN2013 CHK L. ZHANG 09JAN2013 APVD S. XI 09JAN2013 PRODUCT SPEC APPLICATION SPEC WEIGHT CUSTOMER ACCESSIBLE PRODUCTION DRAWING		NAME Ocean End Feed Applicator SIZE CAGE CODE DRAWING NO. A1 00779 C=2150308 SCALE 1:1 SHEET 2 OF 4 REV C		RESTRICTED TO	
--------------------	--	---	--	--	--	---	--	---------------	--

PART NUMBER	REVISION	DESCRIPTION	FEED TYPE
2-2150308-1	C	FINE CRIMP HEIGHT ADJUST	MECHANICAL
2-2150308-2	C	FINE CRIMP HEIGHT ADJUST	PNEUMATIC
7-2150308-7	A	CRIMP TOOLING KIT	-

PACIFIC VERSION TERMINATOR
INTERFACE ADAPTER



APPLICATOR DATA		
CRIMP	SIZE	TYPE
WIRE	3.05 mm [.120]	F
INSUL	3.94 mm [.155]	F
APPLICATOR INSTRUCTIONS 408-35043		

TERMINAL DATA: TE TERMINAL				TE CRIMP SPECIFICATION			
TERMINAL NAME: .187 SR. FASTIN-FASTON REC. TERM.							
WIRE STRIP LENGTH 3.75-4.51 mm [.148-.178 IN]				INSULATION DIAMETER RANGE Ø3.00-4.30 mm [.118-.169 IN]			
TERMINAL APPLICATION SPECIFICATION 114-20011							
TERMINALS APPLIED							
TE TERMINAL	TE TERMINAL	TE TERMINAL	TE TERMINAL	TE TERMINAL	TE TERMINAL	TE TERMINAL	TE TERMINAL
281197-2							

TERMINAL DATA: TE TERMINAL				TE CRIMP SPECIFICATION			
TERMINAL NAME: .187 SR. FASTIN-FASTON REC. TERM.							
WIRE STRIP LENGTH 3.75-4.51 mm [.148-.178 IN]				INSULATION DIAMETER RANGE Ø3.00-4.30 mm [.118-.169 IN]			
TERMINAL APPLICATION SPECIFICATION							
TERMINALS APPLIED							
TE TERMINAL	TE TERMINAL	TE TERMINAL	TE TERMINAL	TE TERMINAL	TE TERMINAL	TE TERMINAL	TE TERMINAL
281197-2							

WIRE SIZE	CRIMP HEIGHT mm [INCH]	CRIMP HEIGHT REFERENCE SETTING
2.50mm2	1.57+/-0.03 [.062+/- .001]	2.1
1.50mm2	1.37+/-0.03 [.054+/- .001]	4.0
1.00mm2	1.27+/-0.03 [.050+/- .001]	5.1

WIRE SIZE	CRIMP HEIGHT mm [INCH]	CRIMP HEIGHT REFERENCE SETTING
1.50+0.50mm	1.57+/-0.03 [.062+/- .001]	2.1
14 AWG	1.50+/-0.03 [.059+/- .001]	2.8

***WARNING**
ON INSTALLATION, SET WIRE DISC TO CRIMP HEIGHT REFERENCE SETTING FOR LARGEST WIRE SIZE. CRIMP HEIGHT REFERENCE SETTINGS GREATER THAN THE VALUE SHOWN MAY CAUSE DAMAGE TO THE CRIMP TOOLING. REFER TO THE INSTRUCTION SHEET FOR PROPER SETUP AND ADJUSTMENTS.

- 1 RECOMMENDED SPARE PARTS
- 2 REFER TO SUPPLIED INSTRUCTION SHEET FOR CLEANING, LUBRICATION AND STORAGE OF APPLICATOR.
- 3 APPLY PART NUMBER 2-23419-6 LOCTITE TO THREADS OF ITEM 242.
- 4 CRIMP HEIGHT REFERENCE SETTING WAS THE SETTING USED WHEN THE APPLICATOR WAS QUALIFIED AT THE FACTORY. ADJUSTMENT MAY BE NECESSARY WHEN RUNNING APPLICATOR IN THE FIELD.
- 5. UNLESS SPECIFIED OTHERWISE TORQUE VALUES SHALL BE USED PER DOCUMENT, 101-35000.
- 6 THIS CRIMP PARAMETER IS PROVIDED TO MEET A CUSTOM AND UNIQUE CUSTOMER REQUIREMENT. IT HAS BEEN EVALUATED AND IS CONDITIONALLY SPECIFIED BY TE CONNECTIVITY. THIS CUSTOMIZED CRIMP PARAMETER IS NOT LISTED AS AN APPROVED APPLICATION WITHIN A TE CONNECTIVITY APPLICATION SPECIFICATION; HOWEVER, IT HAS BEEN VALIDATED ACCORDING TO TE CONNECTIVITY SPECIFICATIONS 109-18079 (TEST GROUP 1) AND 114-18022. TE CONNECTIVITY EXPRESSLY DISCLAIMS ANY AND ALL WARRANTIES THAT THE PRODUCT WILL PERFORM SIMILARLY TO VALIDATED AND APPROVED APPLICATIONS, AS STATED WITHIN TE CONNECTIVITY APPLICATION SPECIFICATIONS, INCLUDING BUT NOT LIMITED TO IMPLIED WARRANTIES OF MERCHANTABILITY OR FITNESS FOR PARTICULAR PURPOSE. AS SUCH, IT IS HIGHLY RECOMMENDED THAT THE CUSTOMER PERFORM FURTHER DETAILED EVALUATION TO ASSESS PRODUCT PERFORMANCE IN THE SPECIFIC APPLICATION.

LOC	DIST	REVISIONS					
A	66	P	LTN	DESCRIPTION	DATE	OWN	APVD
		-	-	SEE SHEET 1	-	-	-

-	1	-	2119640-1	PUSH ROD, AIR FEED	250
-	1	-	1803259-1	BUSHING, FLANGED	249
-	1	1	2119082-9	CAM, SNAIL, INSULATION ADJUSTMENT	244
-	1	1	2079764-1	WASHER, WAVE SPRING, CREST-TO-CREST	243
3	-	1	2119083-1	RETAINER, INSULATION DIAL	242
-	-	1	2119580-1	MECHANICAL FEED ASSEMBLY	239
-	1	-	2063440-1	AIR FEED MODULE	238
-	1	1	1-18028-0	WASHER, FLAT, REG M8	192
-	4	4	2079383-9	SCR, BHSC, RoHS (M6 X 20)	186
-	2	-	21045-3	RING, RETAIN, EXTERN, 3/16 CRESCENT	172
-	REF	REF	994970-2	COUNTER, MAGNETIC	164
-	1	-	240638-1	SPRING, FEED FINGER	163
-	1	-	2119641-2	FEED CAM, AIR FEED	152
-	1	1	2168083-8	SCR, SKT HD CAP, RoHS, M4 X 16	144
-	-	1	2119653-2	FEED CAM, POST FEED	142
-	1	1	2119655-6	APPLICATOR BASIC ASSEMBLY, EF	141
-	1	1	1803518-1	RAM ASSEMBLY, EF PACIFIC	140
-	1	-	3-23627-7	PIN, RETAIN, GRVD, 3/16 X .854	137
-	1	1	1-455888-0	SPACER, CRIMPER	82
-	1	1	2119791-9	DEPRESSOR, WIRE	73
-	1	1	1803607-2	DOCUMENTATION PACKAGE	71
-	2	2	2-18032-2	SCR, SET, FLT PNT, M3 X 10.0	70
-	1	1	2119943-1	WASHER, SPACER	69
-	1	1	2119740-1	TAG, IDENTIFICATION	67
-	2	2	2168078-1	SCREW, DRIVE, RH, RoHS, 2 x .188	66
-	2	2	2168400-5	SHCS, LOW HEAD, RoHS, M4 X 20	64
-	-	1	5-18022-5	SCR, HEX HD CAP, M4 X 6.0	59
-	-	1	2063961-1	FEED FINGER	58
-	3	3	2168400-4	SHCS, LOW HEAD, RoHS, M4 X 8	57
-	2	2	2168083-2	SCR, SKT HD CAP, RoHS, M4 X 8.0	56
-	2	2	5018030-1	NUT, HEX, REG, RoHS, M3	54
-	2	2	986965-8	NUT, LOCK, HEX, TORQUE (M4)	53
-	1	-	2119792-2	PAWL, EF, AIR	51
-	1	2	18023-9	SCR, SKT HD CAP M4 X 6.0	49
-	-	1	2119652-1	FEED CAM, PRE FEED	48
-	1	1	1803602-1	SCR, BHSC, RoHS (M8 X 25)	41
-	7	7	1-18028-2	WASHER, FLAT, REG M4	33
-	2	2	2168083-9	SCR, SKT HD CAP, RoHS, M4 X 20	31
-	2	2	2168083-2	SCR, SKT HD CAP, RoHS, M4 X 8.0	29
-	1	1	240639-4	STRIPPER (MACHINING)	27
-	2	2	1-2168083-5	SCR, SKT HD CAP, RoHS, M4 X 30	25
-	1	1	1752371-9	PLATE, STRIP GUIDE	24
-	1	1	240825-2	PLATE, STRIP HOLD DOWN	23
-	2	2	2-22281-3	SPRING, COMPRESSION	22
-	1	1	1803292-4	DRAG	20
-	2	2	1901259-5	GUIDE, LOWER STRIP	18
1	-	1	240833-3	PLATE, REAR SHEAR	11
-	-	-	-	-	10
1	-	1	690496-7	PLATE, FRONT SHEAR	9
1	1	1	1333220-1	ANVIL, COMBINATION, .120	8
1	-	1	2217206-4	BLADE, SLUG	7
-	-	-	-	-	6
-	1	1	240641-2	SPACER	5
-	1	1	238011-2	BLOCK, CRIMPER SPACER	4
1	1	1	3-2119582-6	CRIMPER, INSULATION F PREMIUM	3
-	-	-	-	-	2
1	1	1	456409-1	CRIMPER, WIRE .120 "F" PREMIUM	1
-	-	-	-	-	1
-	-	-	-	-	1

PACIFIC VERSION
Shown on sheets 3 of 4 & 4 of 4
(Atlantic version shown on sheets 1 of 4 & 2 of 4)

DIMENSIONS:		TOLERANCES UNLESS OTHERWISE SPECIFIED:		DRAWING NO	
mm	0 PLC ±	1 PLC ±	2 PLC ±	3 PLC ±	4 PLC ±
	ANGLES ±	FINISH ±			
MATERIAL		FINISH		WEIGHT	
				A1 00779 C=2150308	
CUSTOMER ACCESSIBLE PRODUCTION DRAWING				SCALE	SHEET 3 OF 4
				REV	C

LOC		DIST		REVISIONS			
A	66	P	LTM	DESCRIPTION	DATE	DWN	APVD
		-		SEE SHEET 1			

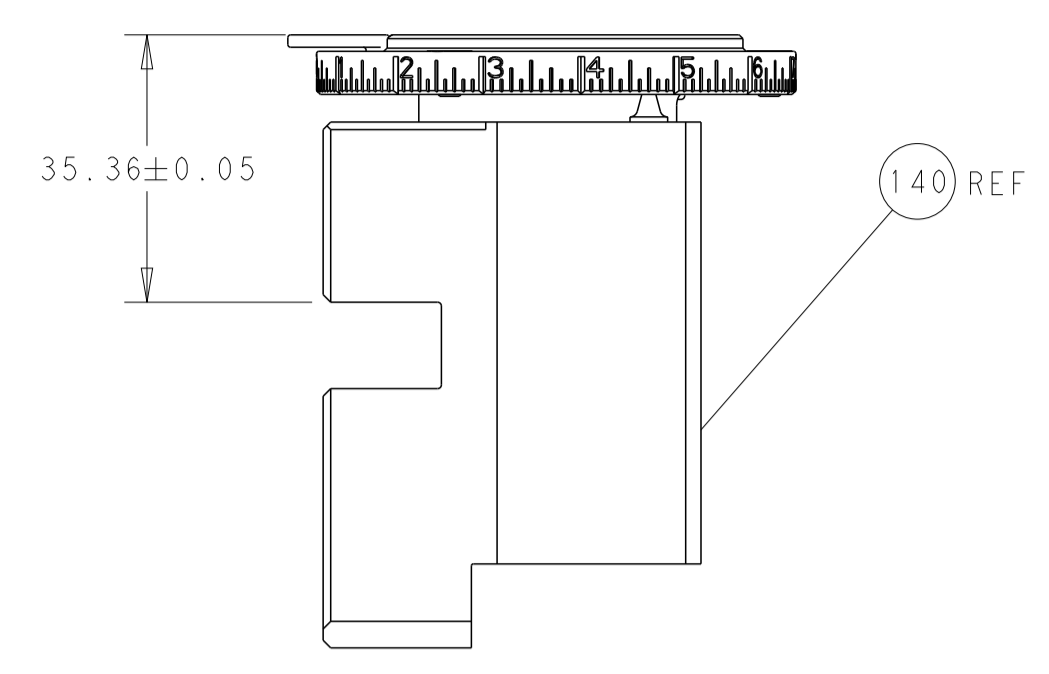

RAM SET-UP

FEED TYPE
MECHANICAL

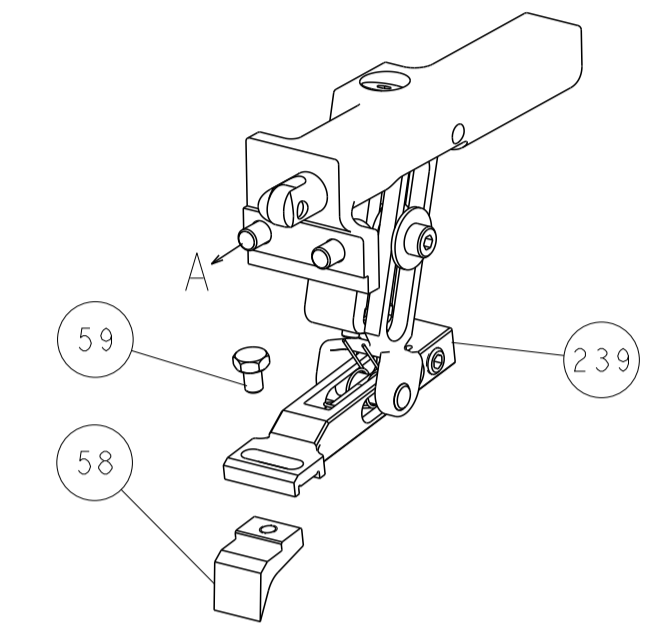

PNEUMATIC

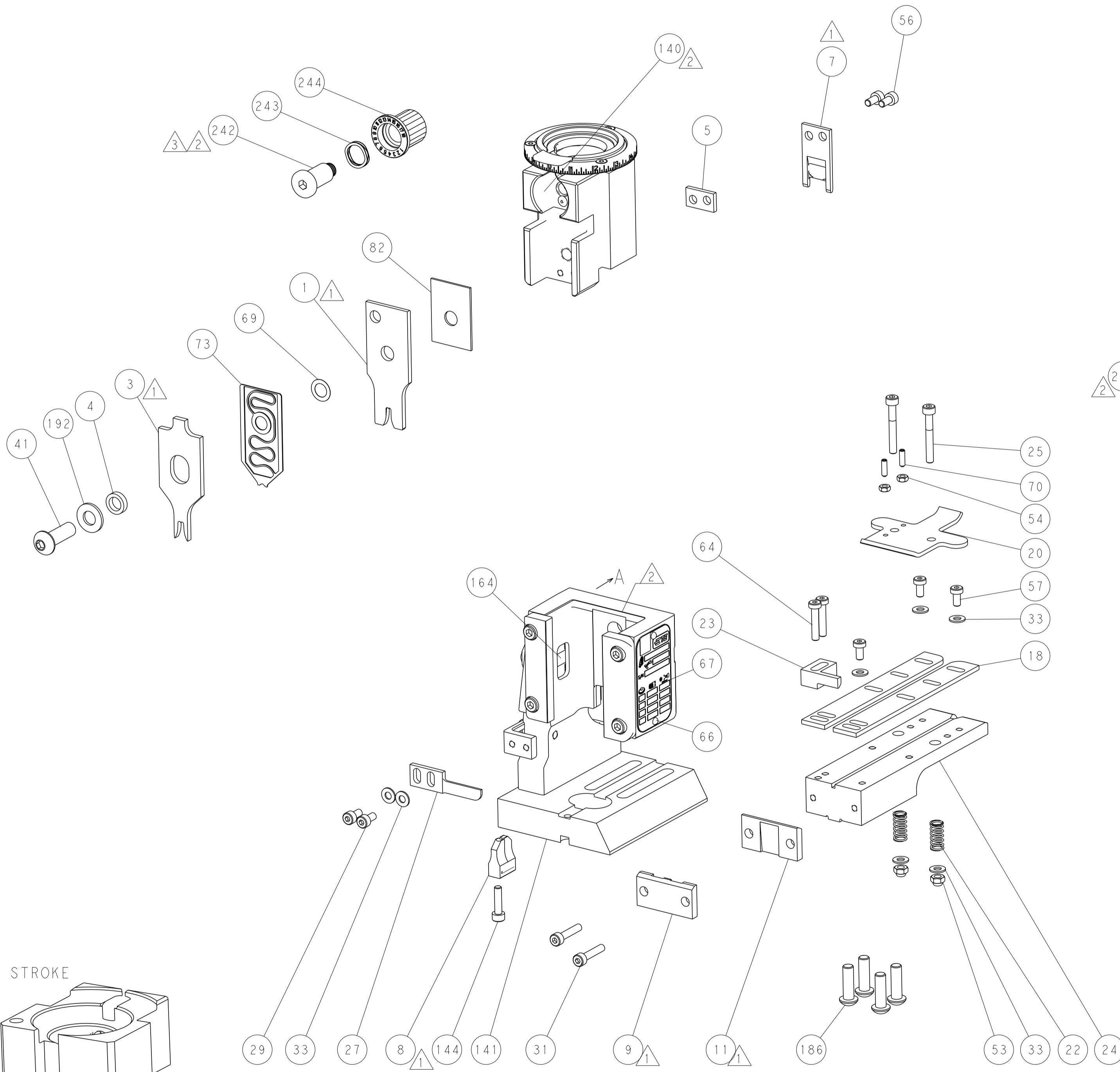
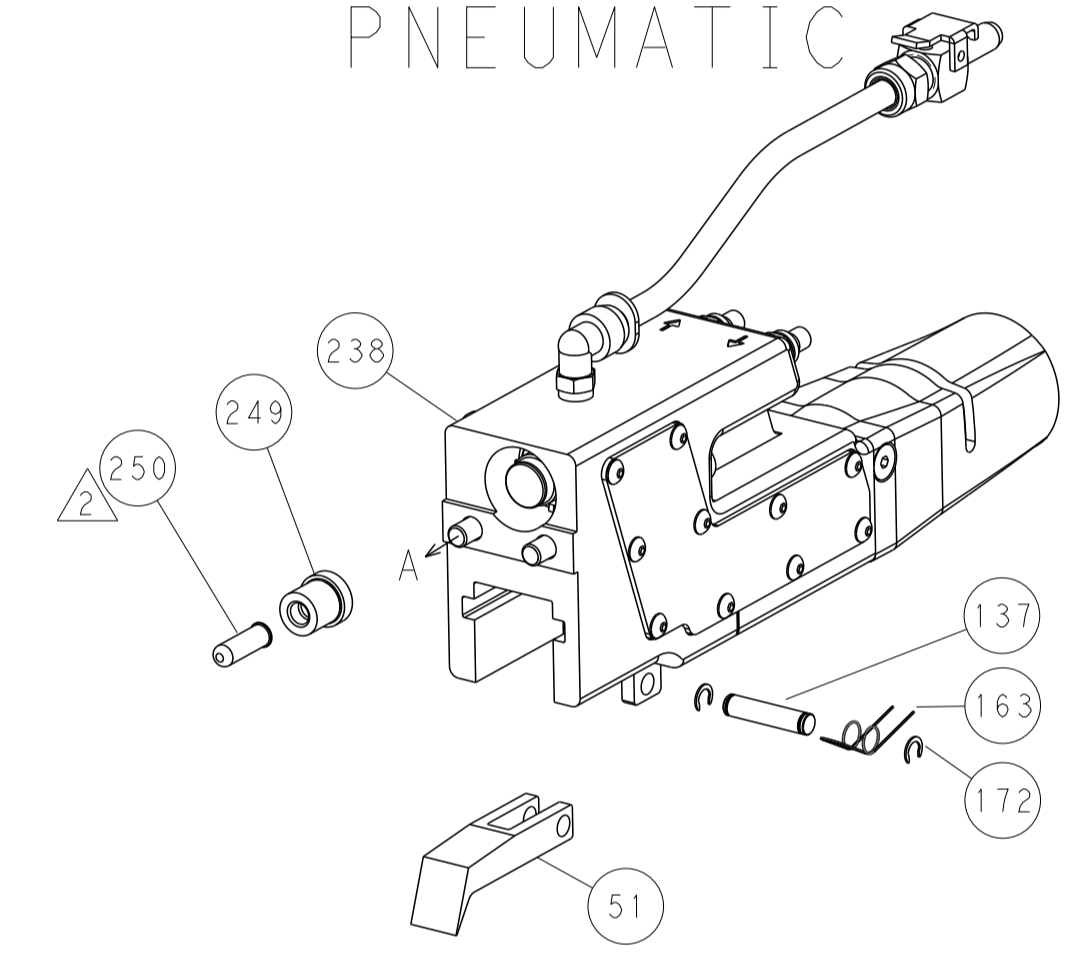

CAM POSITIONS

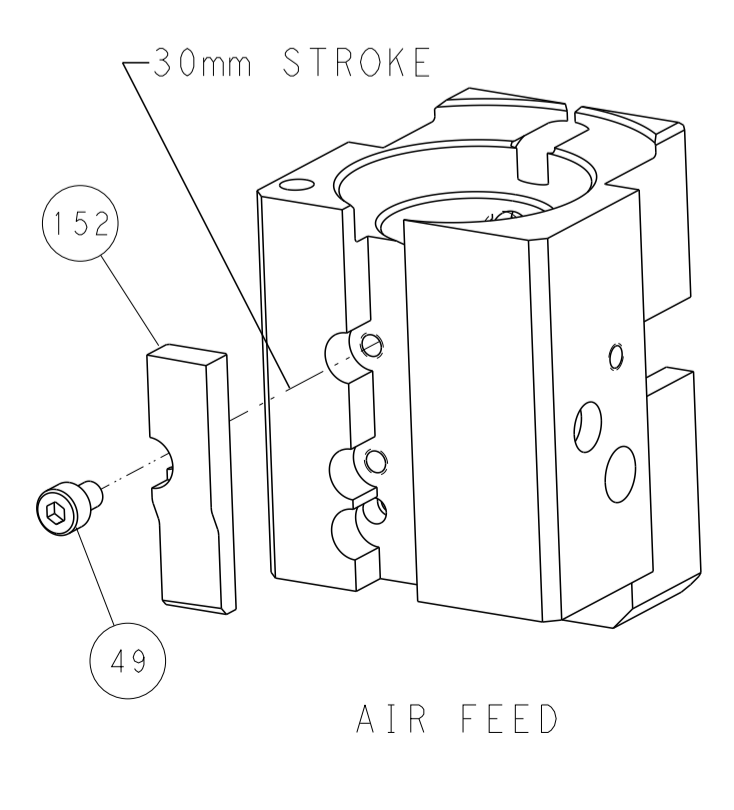
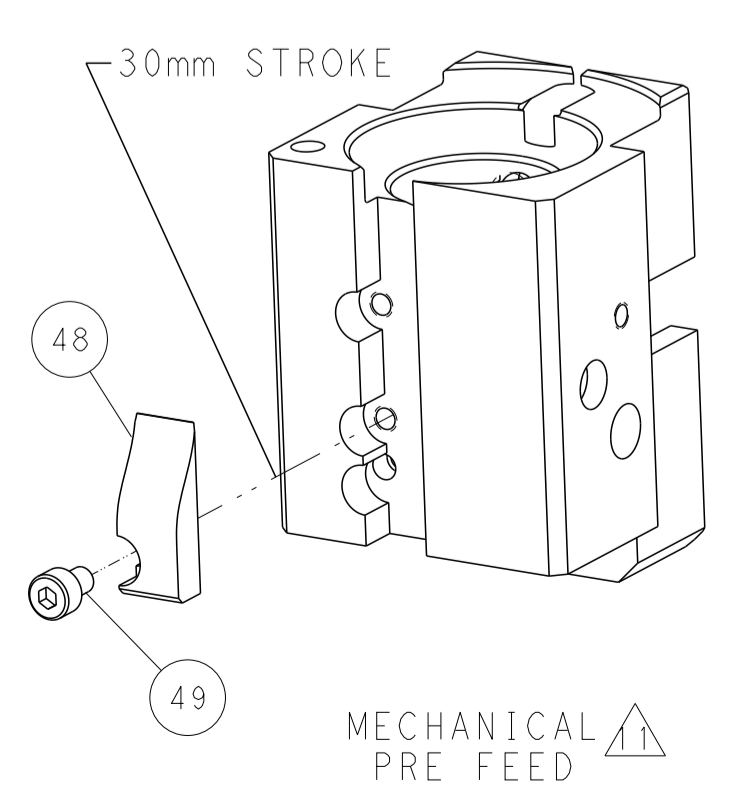
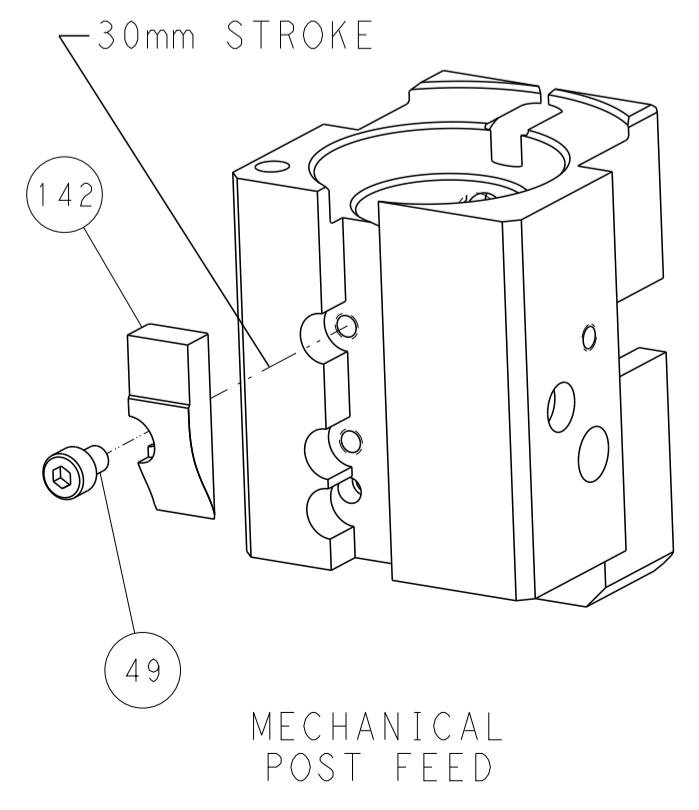

PACIFIC VERSION
 Shown on sheets 3 of 4 & 4 of 4
 (Atlantic version shown on sheets 1 of 4 & 2 of 4)

<small>THIS DRAWING IS UNPUBLISHED. RELEASED FOR PUBLICATION BY TYCO ELECTRONICS CORPORATION. ALL RIGHTS RESERVED.</small>		DWN L. ZHANG 09JAN2013 CHK L. ZHANG 09JAN2013 S. XI 09JAN2013 APVD S. XI 09JAN2013	TE Connectivity Harrisburg, PA 17105-3608
DIMENSIONS: mm TOLERANCES UNLESS OTHERWISE SPECIFIED: 0 PLC ± 1 PLC ± 2 PLC ± 3 PLC ± 4 PLC ± ANGLES FINISH ±		NAME Ocean End Feed Applicator SIZE A1 CAGE CODE 00779 DRAWING NO. C=2150308	RESTRICTED TO SCALE 1:1 SHEET 4 OF 4 REV C
MATERIAL:		CUSTOMER ACCESSIBLE PRODUCTION DRAWING	