

DESCRIPTION: MALE - HIGH DENSITY - MACHINED CONTACTS - SOLDER CUP

MATERIALS AND FINISH:

SHELL: STEEL MATERIAL, NICKEL FINISH
 INSULATOR: PBT THERMOPLASTIC 30% GLASS FILLED
 UL 94 V-0 RATED, BLACK
 (PROCESS TEMP 230°C)
 CONTACT MATERIAL: BRASS
 CONTACT FINISH: SELECTIVE GOLD FINISHED
 SEALING MATERIAL: F08 FLEXIBLE ADHESIVE

ELECTRICAL:

CONTACT CURRENT RATING: 3 AMPS
 CONTACT RESISTANCE: 30 mOHMS Max.
 DIELECTRIC WITHSTANDING VOLTAGE: 1,000VAC Min.
 INSULATION RESISTANCE: 5 GOHMS Min.
 TEMPERATURE RATING: -55° ~ +105° C

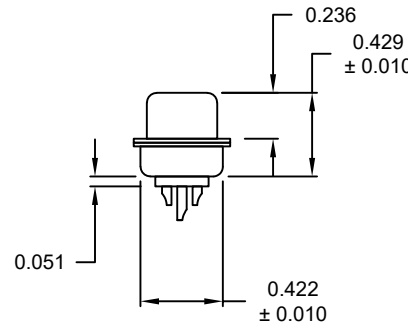
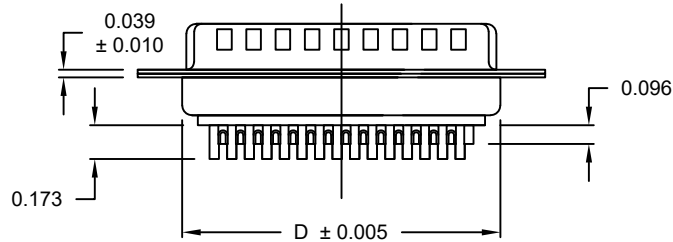
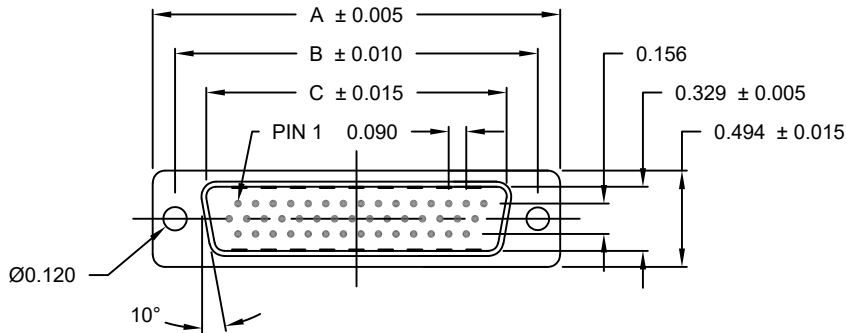

DIMENSIONS				
No. OF PINS	A	B	C	D
15	1.213	0.984	0.666	0.759
26	1.541	1.312	0.994	1.083
44	2.088	1.852	1.534	1.625

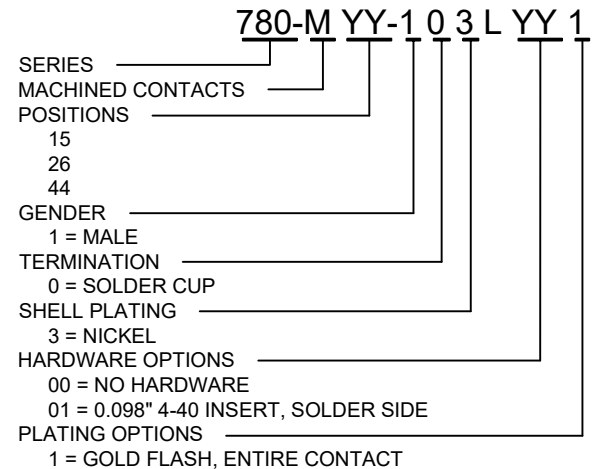

MEETS IP67 STANDARDS
 (SEE PAGE 3 FOR SEALING DETAILS)

ACCEPTS 28 - 24 AWG WIRE

RoHS COMPLIANT

UNITS = inch

DO NOT SCALE FROM DRAWING



THESE DRAWINGS AND SPECIFICATIONS ARE THE PROPERTY OF NorComp AND SHALL NOT BE REPRODUCED, COPIED OR USED AS THE BASIS FOR THE MANUFACTURE OR SALE OF APPARATUS WITHOUT WRITTEN PERMISSION.

DRAWN: C. SMITH
 DATE: 06/11/2009

NorComp

SCALE: NTS SHEET 1 OF 3 REV 5
 DWG NO. 780-MYY-103L YY1

ALL CLINCH-NUTS ARE 4-40 INTERNAL THREADS

01X 0.098" (SOLDER SIDE)

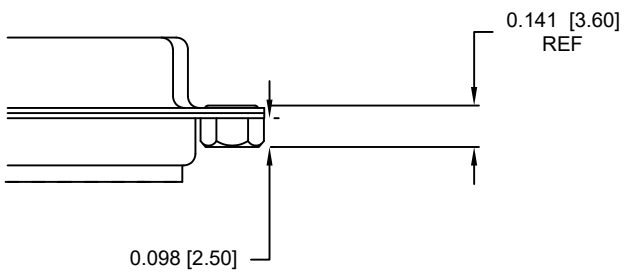

RoHS COMPLIANT

UNITS = inch [mm]

DO NOT SCALE FROM DRAWING



THESE DRAWINGS AND SPECIFICATIONS ARE THE PROPERTY OF NorComp AND SHALL NOT BE REPRODUCED, COPIED OR USED AS THE BASIS FOR THE MANUFACTURE OR SALE OF APPARATUS WITHOUT WRITTEN PERMISSION.

DRAWN:
C. SMITH
DATE:
06/11/2009

NorComp

SCALE: NTS	SHEET 2	OF 3	REV 5
DWG NO.		780-MYY-103LYY1	

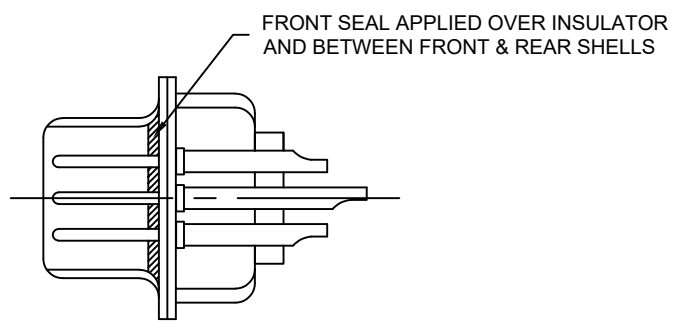
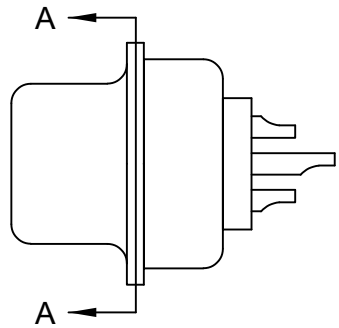

DETAIL A-A

RoHS COMPLIANT

DO NOT SCALE FROM DRAWING



THESE DRAWINGS AND SPECIFICATIONS ARE THE PROPERTY OF NorComp AND SHALL NOT BE REPRODUCED, COPIED OR USED AS THE BASIS FOR THE MANUFACTURE OR SALE OF APPARATUS WITHOUT WRITTEN PERMISSION.

DRAWN:
C. SMITH
DATE:
06/11/2009

NorComp

SCALE: NTS	SHEET 3	OF 3	REV 5
DWG NO.		780-MYY-103LYY1	