

18 Bit RGB, 8/16-bit parallel, SPI interface



*Dimension Display 54.7x83x2.2mm
Incl. PCAP 65x100x4.35mm*

FEATURES

- 3.5" TFT DISPLAY, IPS TECHNOLOGY
- 320x480 WIDE SCREEN
- OPTIONALLY PCAP TOUCHPANEL OPTICALLY BONDED
- SUPER BRIGHT >1000cd/m² (850 cd/m² INCL. PCAP)
- HIGH CONTRAST TFT PANEL
- INTEGRATED CONTROLLER HX8357D
- 18 BIT RGB INTERFACE
- 8 BIT / 16 BIT DATABUS INTERFACE
- I²C BUS INTERFACE FOR PCAP
- 3.3V SUPPLY VOLTAGE
- WIDE TEMPERATURE RANGE (T_{OP} -20 .. +70°C)
- INDUSTRIAL GRADE DISPLAY

ORDERING CODES

3.5" TFT, 320x480 IPS COLOR DISPLAY 1000cd/m²
AS ABOVE BUT WITH OPTICALLY BONDED PCAP

EA TFT035-34AINN
EA TFT035-34AITC

ACCESSORY

ZIF CONNECTOR 0.3MM, BOTTOM CONTACT
(Datasheet: <https://www.lcd-module.de/eng/pdf/zubehoer/WF030-39S.pdf>)

EA WF030-39S

REVISION

DATE	REF.PAGE PARAGRAPH DRAWING No.	REVISED No.	SUMMARY	REMARK
2020-03-18		V01	First Issue	
2021-05-20		V02	Addes initialisation example	

CONTENTS

FEATURES.....	1
ORDERING CODES	1
Accessory	1
Revision.....	2
1. General Specification	4
2.1 Mechanical Drawing EA TFT035-34AINN.....	5
2.2 Mechanical Drawing EA TFT035-34AITC (with PCAP).....	6
3. Block Diagram	7
4. Interface Pin Function	8
5. Absolute Maximum Ratings.....	9
6. Electrical Characteristics.....	9
6.1 Input Power	9
6.2 Backlight Driving Conditions.....	9
6.3 PCAP Electrical Characteristics	10
7. Optical Characteristics	11
8. Timing Characteristics	14
8.1 SPI interface characteristics.....	14
8.2 RGB interface characteristics	15
8.3 Reset input timing.....	17
9. PCAP touchpanel	18
9.1 Timing Specifications for CTP	18
I ² C Communication	18
Data Transmission	20
Write Data to module.....	20
Read Data from module.....	20
9.2 Register Information.....	21
9.3 Function Mode.....	29
10. Standard Specification for Reliability	31
10.1 Standard Specification for Reliability of LCD Module	31
10.2 Testing Conditions and Inspection Criteria	37
10.3 MTBF	37
11. Specification of Quality Assurance	38
11.1 Quality Test	38
11.2 Delivery Test	38
11.3 Non-conforming Analysis & Deal With Manners	38
11.3.1 Non-conforming Analysis	38
11.3.2 Disposition of non-conforming.....	38
11.4 Agreement items.....	39
11.5 Standard of The Product Appearance Test	39
11.5.1 Manner of appearance test	39
11.5.2 Basic principle	40
12. Handling Precaution.....	41
12.1 Handling of LCM	41
12.2 Storage.....	41
12.3 Soldering.....	41
13. Initialisation example RGB565	42

1. GENERAL SPECIFICATION

Item	Contents	Unit
LCD type	TFT/Transmissive normally black	
Module size (W*H*T)	65.0*100.0*4.35	mm
w. PCAP	54.66*82.94*2.2	mm
Active size (W*H)	48.96*73.44	mm
Pixel pitch (W*H)	0.153*0.153	mm
Number of dots	320*RGB*480	
Driver IC	HX8357D	
Interface type	8-Bit, 16-Bit, 18-Bit RGB	
Top polarizer type	Anti-Glare	
Recommend viewing direction	All around	°
Gary scale inversion direction	--	°
Backlight type	6 dies white LED	
Touch panel type	Capacitive, EA TFT035-34AITC only	
Touch panel controller	GT911, EA TFT035-34AITC only	

2.1 MECHANICAL DRAWING EA TFT035-34AINN

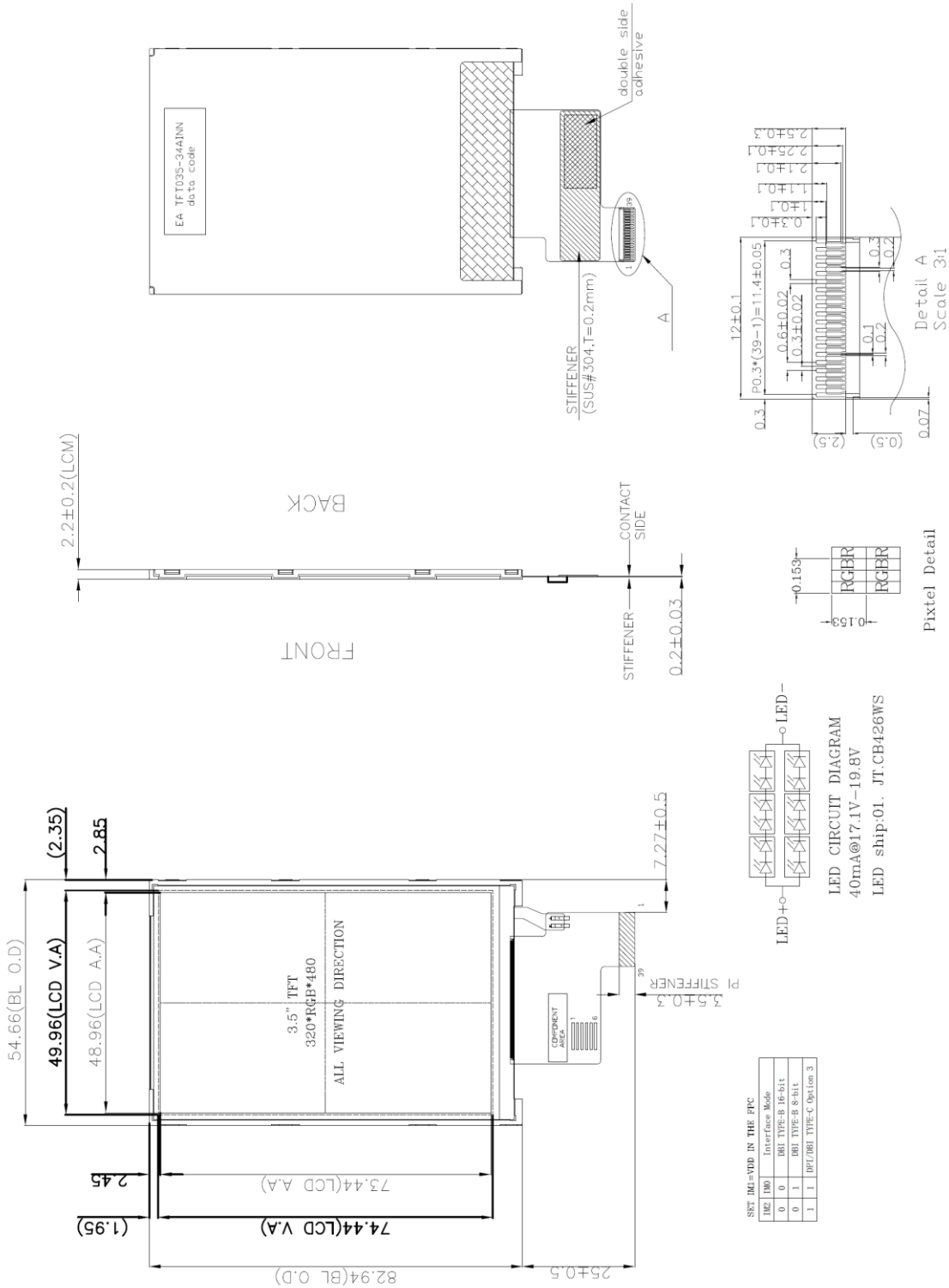

2.2 MECHANICAL DRAWING EA TFT035-34AITC (with PCAP)

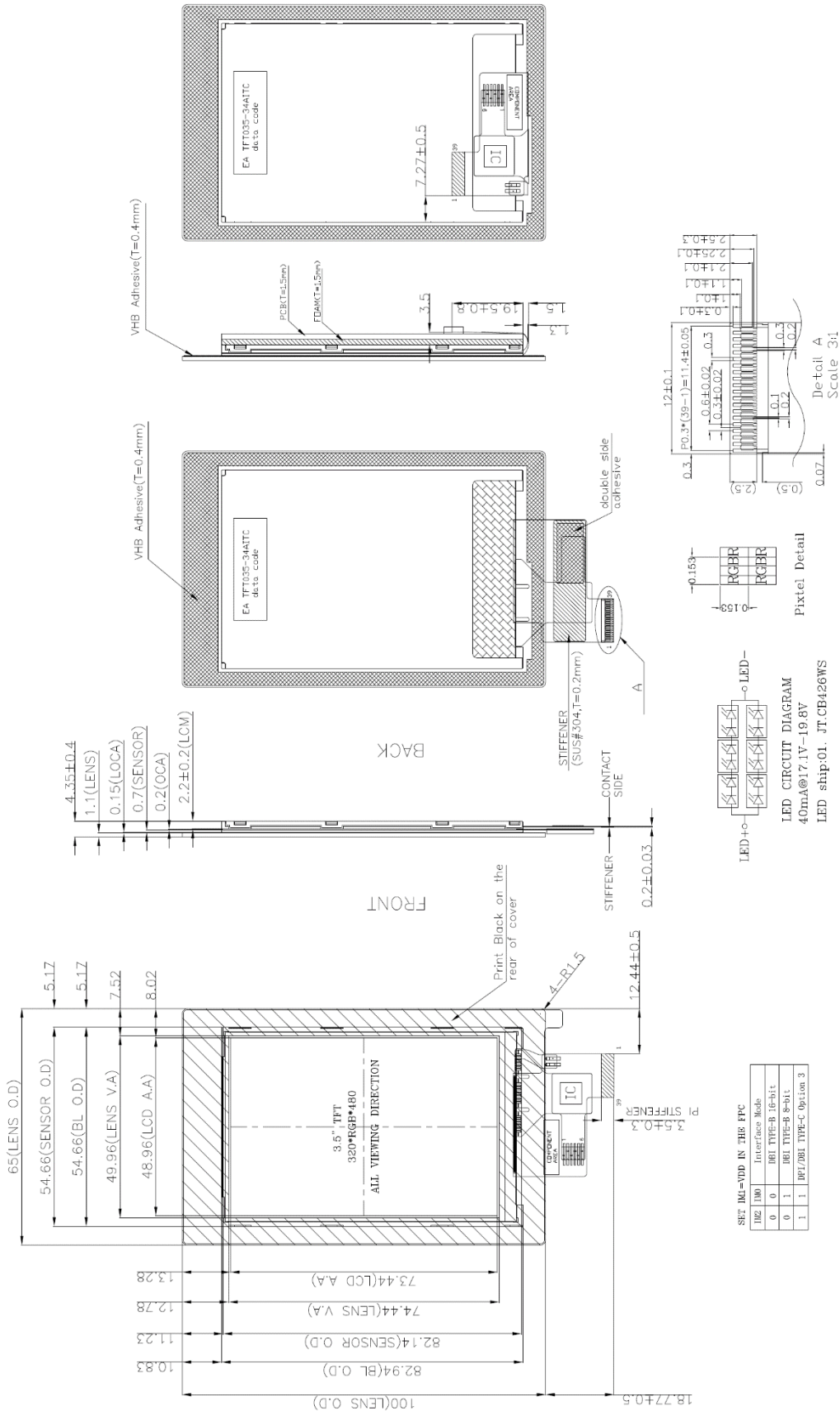

3. BLOCK DIAGRAM

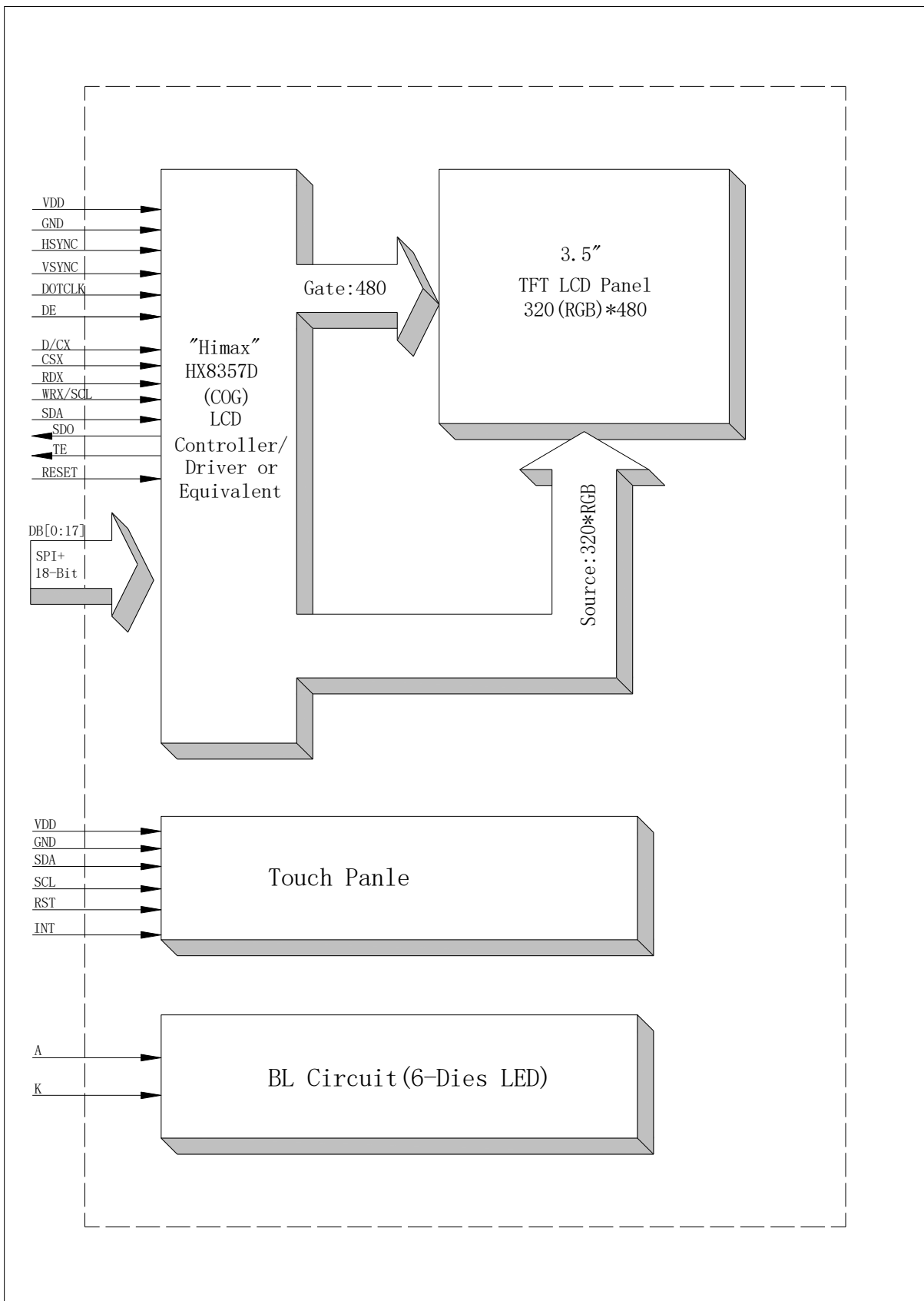

4. INTERFACE PIN FUNCTION

Pin	Symbol	Description
1	LED-	Cathode of LED backlight.
2	LED+	Anode of LED backlight.
3	VDD / TOUCH VDD	Power supply for analog voltage.
4	GND / TOUCH GND	Power ground.
5~10	D0~D5	Data bus or B0..B5
11~16	D6~D11	Data bus or G0..G5
17~22	D12~D17	Data bus or R0..R5
23	DOTCLK	Data enable signal in RGB interface. If this pin is not used, connect it to GND.
24	ENABLE	A data ENABLE signal in RGB mode. If this pin is not used, connect it to GND.
25	HSYNC	Horizontal synchronizing signal in RGB interface. If this pin is not used, connect it to GND.
26	VSYNC	Vertical synchronizing signal in RGB interface. If this pin is not used, connect it to GND.
27	TE	Tearing effect output. If not used, please open this pin.
28	CSX	Chip select signal. Low: chip can be accessed; High: chip cannot be accessed. If this pin is not used, connect it to VDD
29	SDA	Serial data input pin and output pin in serial bus system interface. The data is inputted on the rising edge of the SCL signal. If not used, please let it open.
30	SDO	Serial data output. If bit SDO_EN=0, SDO is not use. If bit SDO_EN=1, SDO is serial data output. If not used, please let it open.
31	D/CX	MPU, SPI-4 line: Data / Command Selection pin. If this pin is not used, connect it to GND.
32	WRX/SCL	MPU mode: Serves as a write signal and write data at the low level. SPI mode: it servers as SCL (Serial Clock) If this pin is not used, connect it to GND.
33	RESET	Reset pin. Setting either pin low initializes the LSI. Must be reset after power is supplied.
34	IM0	Note
35	IM2	
36	RDX	MPU mode: Serves as a read signal and read data at the low level. If this pin is not used, connect it to GND.
37	TOUCH CLK	I2C clock input (EA TFT035-34AITC only)
38	TOUCH SDA	I2C data input and output (EA TFT035-34AITC only)
39	TOUCH INT	Interrupt request to the host or Wakeup request from the host (EA TFT035-34AITC only)

Note

IM2	IM0	Interface Mode (IM1 is connected with VDD internally)
0	0	16-bit bus DBI TYPE-B
0	1	8-bit bus DBI TYPE-B
1	1	16 Bit RGB DPI/DBI TYPE-C Option 3

5. ABSOLUTE MAXIMUM RATINGS

Parameter	Symbol	Min	Max	Unit
Supply voltage for analog	VCC	-0.3	4.6	V
Supply voltage for logic	IOVCC	-0.3	4.6	V
Supply current (LED)	I _{LED}		60	mA
Operating temperature	T _{OP}	-20	+70	°C
Storage temperature	T _{ST}	-30	+80	°C

6. ELECTRICAL CHARACTERISTICS

6.1 INPUT POWER

Item	Symbol	Min	Typ.	Max	Unit
Supply Voltage for Analog	VCC	2.5	2.8	3.3	V
Supply Voltage for Logic	IOVCC	1.65	1.8/2.8	3.3	V
Input Voltage	V _{IL}	GND	-	0.3IOVCC	V
	V _{IH}	0.7 IOVCC	-	IOVCC	
Input leakage Current	I _{LKG}	-1		1	μA

6.2 BACKLIGHT DRIVING CONDITIONS

Item	Symbol	Value			Unit	Remark
		Min.	Typ.	Max.		
Voltage for LED Backlight	V _F	17.1	19.2	19.8	V	I _{LED} =40mA
Current for LED Backlight	I _{LED}		40		mA	
Power Consumption	P		0.768		W	
LED Life Time		30,000			Hr	Note

Note: Brightness to be decreased to 50% of the initial value at ambient temperature T_A=25°C

6.3 PCAP ELECTRICAL CHARACTERISTICS

FPC Design	Item	Description	Remark
COF	IC solution on TP Model	GT911	
	Touch Count Max	5 Point	
	Display Resolution	320*480	
	Interface Type	I2C	
	I2C Slave Address	0xBA/0xBB	
	Origin of Coordinate	Top left corner	

Parameter	Symbol	Min	Typ.	Max	Unit
Interface Signal for Analog	VDD	2.7	3.3	3.6	V
Supply Voltage for Logic	IOVCC	1.71	3.3	3.6	V

7. OPTICAL CHARACTERISTICS

ITEM	SYMBOL	CONDITIONS	SPECIFICATIONS			UNIT
			MIN	TYP.	MAX	
Luminance	L	EA TFT035-43-AINN	800	1000	1400	cd/m ²
		EA TFT035-43-AITC	510	850	1200	cd/m ²
Contrast Ratio	CR	$\theta=0^\circ$		700		
Response Time	T _{ON}	25°C		30		ms
	T _{OFF}					
CIE Color Coordinate	X _W		0.27	0.31	0.35	
	Y _W		0.32	0.36	0.40	
Viewing Angle	Hor.	θ_{X+}	CR≥10		80	Degree
		θ_{X-}			80	
	Ver.	θ_{Y+}			80	
		θ_{Y-}			80	
Uniformity			80			%

Note 1: Definition of Viewing Angle θ_x and θ_y :

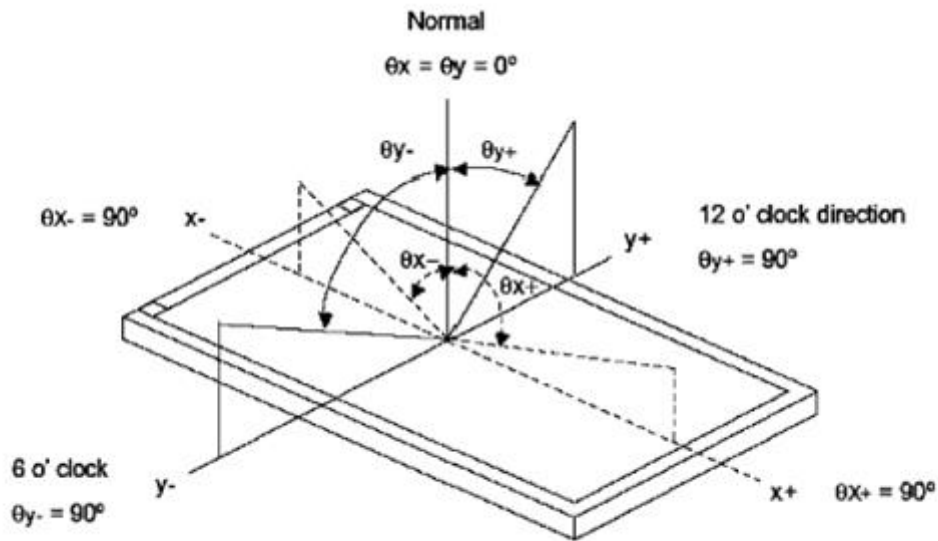

Note 2: Definition of contrast ratio CR:

$$CR = \frac{\text{Luminance of white state}}{\text{Luminance of black state}}$$

Note 3: Definition of Response Time (T_r, T_f)

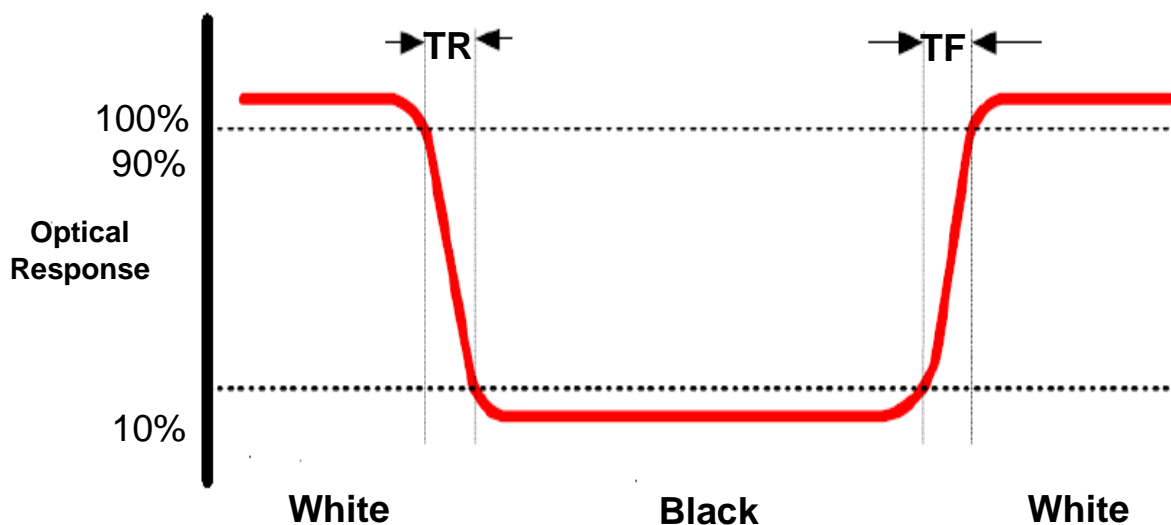

Note 4: Definition of Luminance

① The Brightness Test Equipment Setup

Field=2° (As measuring "black" image, field=2° is the best testing condition)

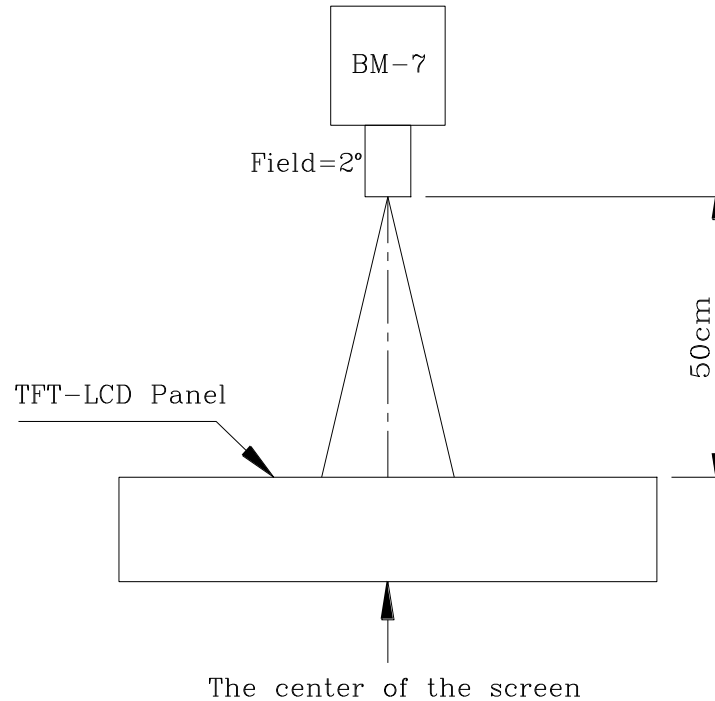

② The Brightness Test Point Setup

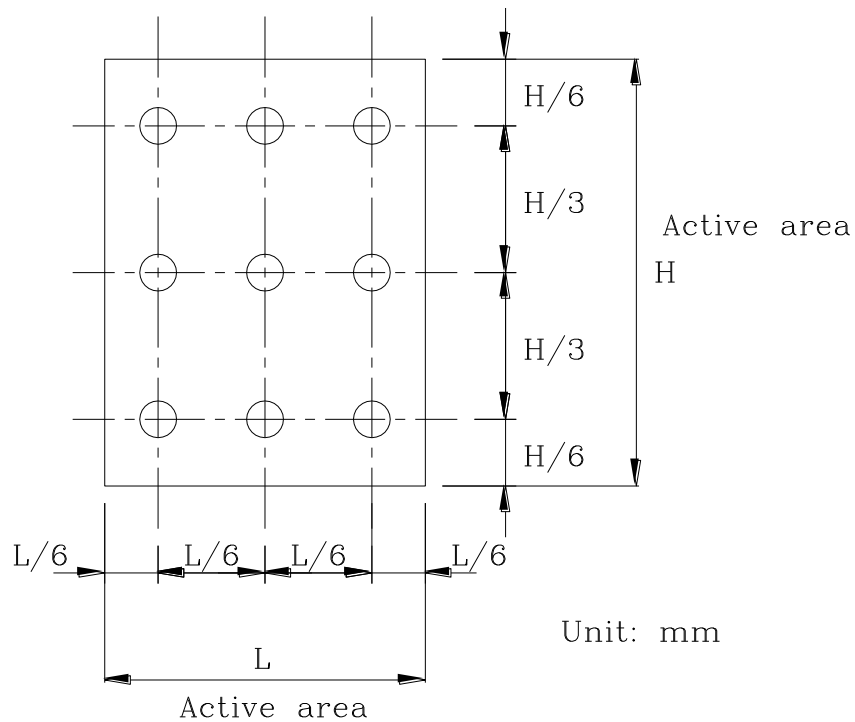

8. TIMING CHARACTERISTICS

8.1 SPI INTERFACE CHARACTERISTICS

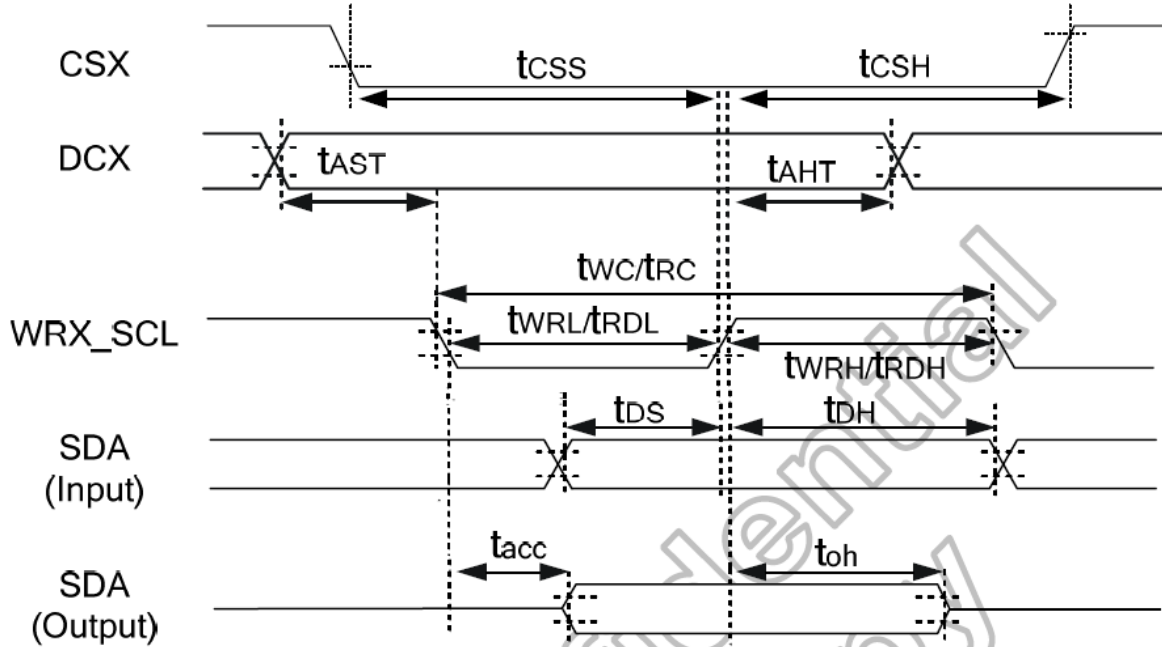

Figure 8.2: SPI interface characteristics

(GND=0V, IOVCC=1.8V, VCI=2.8V, $T_A=25^\circ\text{C}$, Sleep Out states)

Signal	Symbol	Parameter	Min.	Max.	Unit	Description
CSX	t_{cSS}	Chip select setup time (Write)	15	-	ns	-
	t_{cSS}	Chip select setup time (Read)	60	-		
	t_{cSH}	Chip select hold time (Write)	15	-		
	t_{cSH}	Chip select hold time (Read)	65	-		
DCX	t_{AST}	Address setup time	0	-	ns	-
	I	Address hold time (Write/Read)	10	-		
WRX_SCL (Write)	t_{WC}	Write cycle	66	-	ns	-
	t_{WRH}	Control pulse "H" duration	15	-		
	t_{WRL}	Control pulse "L" duration	15	-		
WRX_SCL (Read)	t_{RC}	Read cycle	150	-	ns	-
	t_{RDH}	Control pulse "H" duration	60	-		
	t_{RDH}	Control pulse "L" duration	60	-		
SDA (Input)	t_{DS}	Data setup time	10	-	ns	For maximum $C_L=30\text{pF}$ For minimum $C_L=8\text{pF}$
	t_{DH}	Data hold time	10	-		
SDA (Output)	t_{ACC}	Read access time	10	50	ns	
	t_{OH}	Output disable time	15	50		

Table 8.2: SPI interface characteristics

Note: The input signal rise time and fall time (t_r , t_f) is specified at 15 ns or less.
Logic high and low levels are specified as 30% and 70% of IOVCC for Input signals.

8.2 RGB INTERFACE CHARACTERISTICS

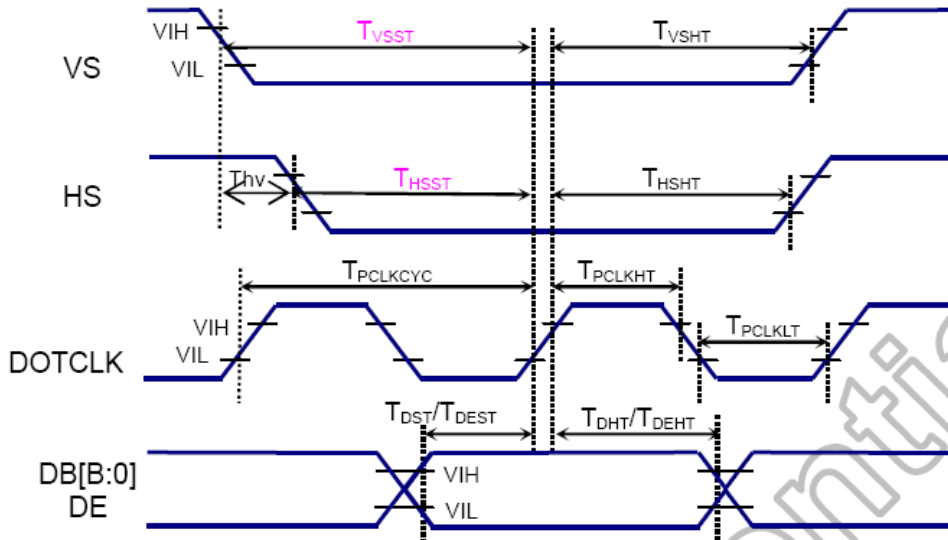

Figure 8.3: RGB interface characteristics

(GND=0V, IOVCC=1.8V, VCI=2.8V, TA=25°C, Sleep Out states)

Item	Symbol	Condition	Spec.			Unit
			Min.	Typ.	Max.	
Pixel low pulse width	T_{CLKLT}	-	15	-	-	ns
Pixel high pulse width	T_{CLKHT}	-	15	-	-	ns
Vertical Sync. Set-up time	T_{VSST}	-	15	-	-	ns
Vertical Sync. Hold time	T_{VSHT}	-	15	-	-	ns
Horizontal Sync. Set-up time	T_{HSST}	-	15	-	-	ns
Horizontal Sync. Hold time	T_{HSHT}	-	15	-	-	ns
Data Enable set-up time	T_{DEST}	-	15	-	-	ns
Data Enable hold time	T_{DEHT}	-	15	-	-	ns
Data set-up time	T_{DST}	-	15	-	-	ns
Data hold time	T_{DHT}	-	15	-	-	ns
Phase difference of sync signal falling edge	Thv	-	0	-	320	Dotclk

Table 8.3: RGB interface characteristics

Note: The input signal rise time and fall time (t_r , t_f) is specified at 15 ns or less.

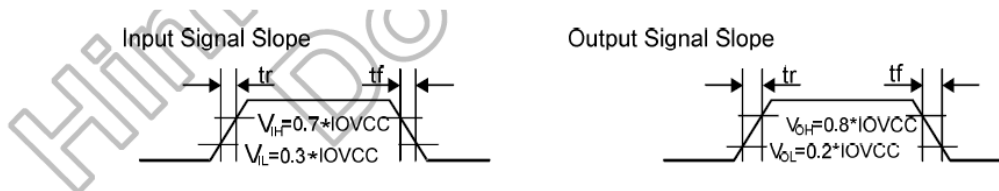

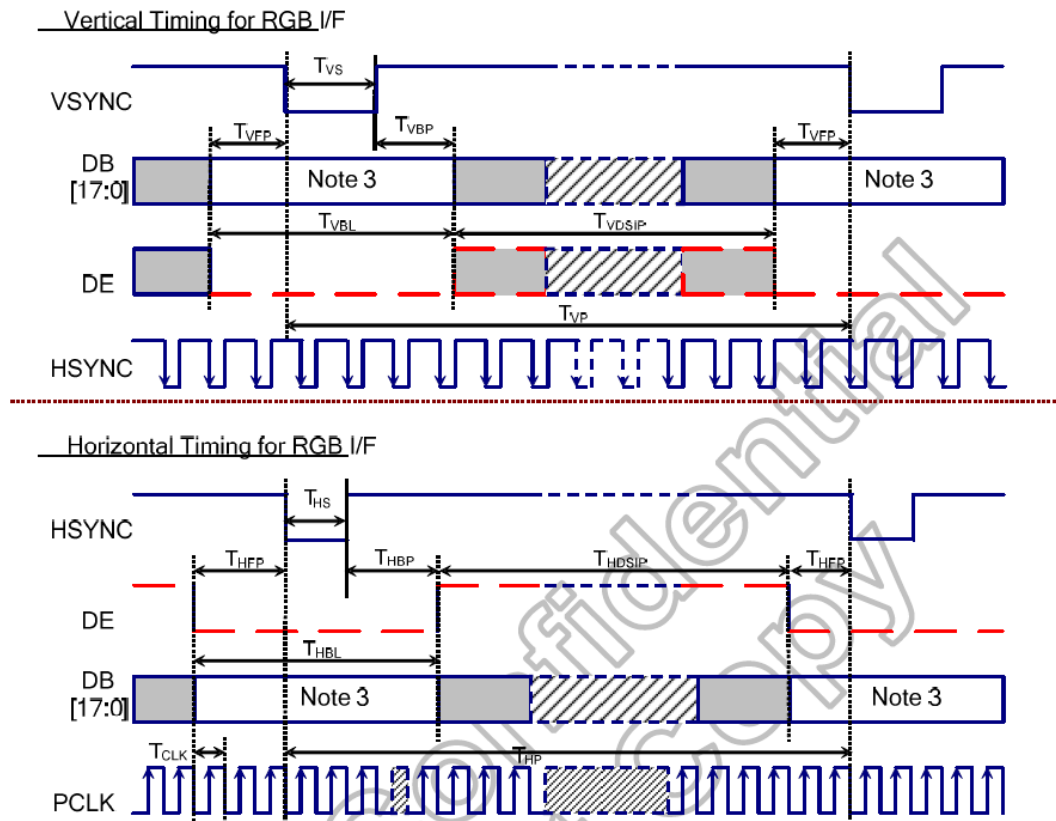

Figure 8.4: General timings for RGB I/F-2

Item	Symbol	Condition	Specification			Unit
			Min.	Typ.	Max.	
Vertical Timing						
Vertical cycle period	T_{VP}	-	486	-	-	HS
Vertical low pulse width	T_{VS}	-	2	-	-	HS
Vertical front porch	T_{VFP}	-	2	-	-	HS
Vertical back porch	T_{VBP}	-	2	-	-	HS
Vertical blanking period	T_{VBL}	$T_{VS} + T_{VBP} + T_{VFP}$	6	-	-	HS
Vertical active area	T_{VDISP}	-	-	480	-	HS
			-		-	HS
Vertical refresh rate	T_{VRR}	Frame rate	50	60	70	Hz
Horizontal Timing						
Horizontal cycle period	T_{HP}	-	335	-	-	DOTCLK
Horizontal low pulse width	T_{HS}	-	5	-	-	DOTCLK
Horizontal front porch	T_{HFP}	-	5	-	-	DOTCLK
Horizontal back porch	T_{HBP}	-	5	-	-	DOTCLK
Horizontal blanking period	T_{HBL}	$T_{HS} + T_{HBP} + T_{HFP}$	15	-	-	DOTCLK
Horizontal active area	T_{HDISP}	-	-	320	-	DOTCLK
Pixel clock cycle TVRR=60Hz	f_{CLKCYC}	-	9	-	-	MHz

Table 8.4: RGB interface characteristics-2

- Note:** (1) IOVCC=1.65 to 3.3V, VCI=2.3 to 3.3V, VSSA=VSSD=0V, Ta=-30 to 70°C
 (2) Data lines can be set to “High” or “Low” during blanking time – Don’t care.
 (3) HP is multiples of PCLK.

8.3 RESET INPUT TIMING

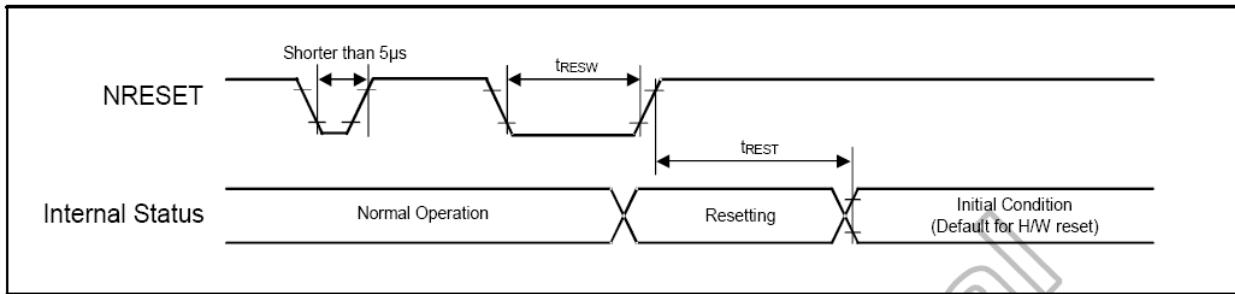

Figure 8.5: Reset input timing

Symbol	Parameter	Related Pins	Spec.			Note	Unit
			Min.	Typ.	Max.		
tRESW	Reset low pulse width ⁽¹⁾	NRESET	10	-	-	-	µs
tREST	Reset complete time ⁽²⁾	-	5	-	-	When reset applied during SLPIN mode	ms
		-	120	-	-	When reset applied during SLPOUT mode	ms

Table 8.5: Reset input timing

Note: (1) Spike due to an electrostatic discharge on NRESET line does not cause irregular system reset according to the following table.

NRESET Pulse	Action
Shorter than 5 µs	Reset Rejected
Longer than 10 µs	Reset
Between 5 µs and 10 µs	Reset Start

- (2) During the resetting period, the display will be blanked (The display is entering blanking sequence, which Maximum time is 120 ms, when Reset Starts in Sleep Out –mode. The display remains the blank state in Sleep In –mode) and then return to Default condition for H/W reset.
- (3) During Reset Complete Time, ID and VCOM value in OTP will be latched to internal register during this period. This loading is done every time when there is H/W reset complete time (tREST) within 5ms after a rising edge of NRESET.
- (4) Spike Rejection also applies during a valid reset pulse as shown as below:

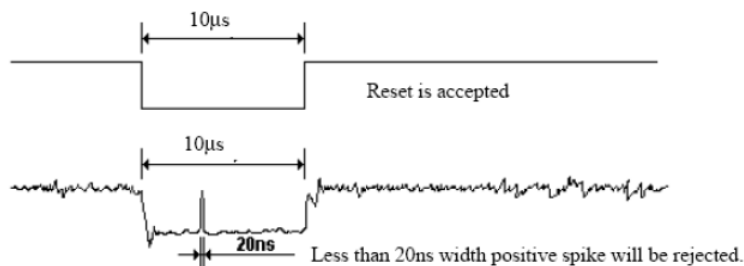

- 01. It is necessary to wait 5msec after releasing NRESET before sending commands. Also Sleep Out command cannot be sent for 120msec.

9. PCAP TOUCHPANEL

Table 9

Item	Specification	Unit
Touch panel Size	3.5	inches
Active Area (Sensor)	49.0 (H) x 73.5 (V)	mm
Input type	Multi touch	
Controller	GT911	
Interface mode	I ² C	
Normal mode operating current	Typ. 8	mA

9.1 TIMING SPECIFICATIONS FOR CTP

I²C Communication

This module provides standard I2C interface for communication. In the system, this module always works in slave mode, all communications are initiated by master, and the baud rate can be up to 400K bps. The definition of I²C timing is as following:

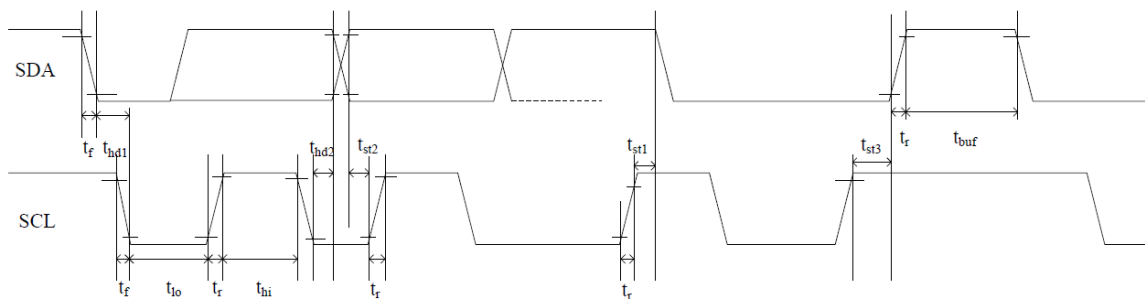

Fig.6 RGB Interface Timing Characteristics

Test condition: 3.3V communication interface, 400Kbps, pull up resistor is 2K ohm

Parameter	Symbol	MIN.	Max.	Unit
SCL low period	t_{lo}	0.9	-	us
SCL high period	t_{hi}	0.8	-	us
SCL setup time for START condition	t_{st1}	0.4	-	us
SCL setup time for STOP condition	t_{st3}	0.4	-	us
SCL hold time for START condition	t_{hd1}	0.3	-	us
SDA setup time	t_{st2}	0.4	-	us
SDA hold time	t_{hd2}	0.4	-	us

This module has 2 sets of slave address 0xBA/0xBB & 0x28/29. Master can control Reset & INT pin to configure the slave address in power on initial state like following:

Power on diagram:

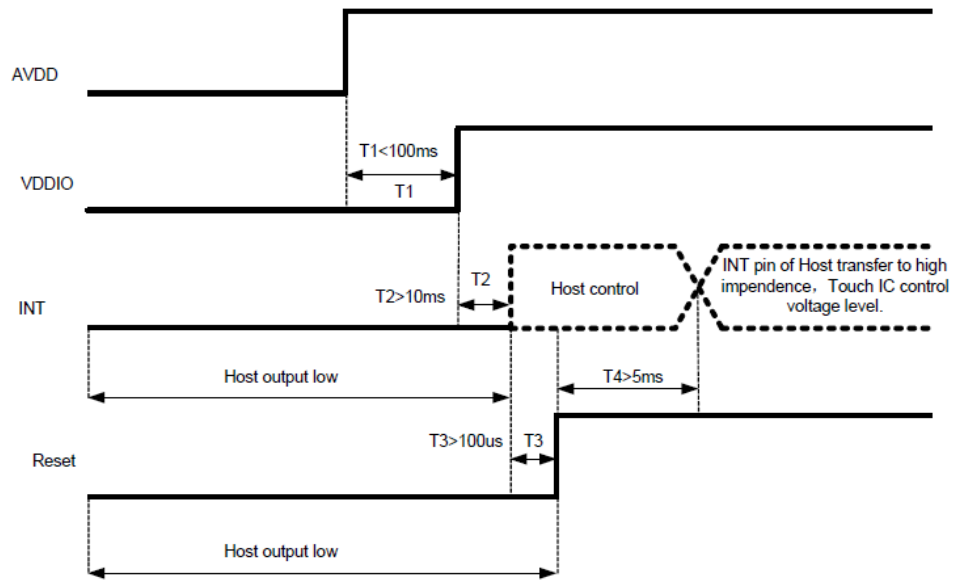

Fig.7 Power on diagram

Timing of setting slave address to 0x28/0x29:

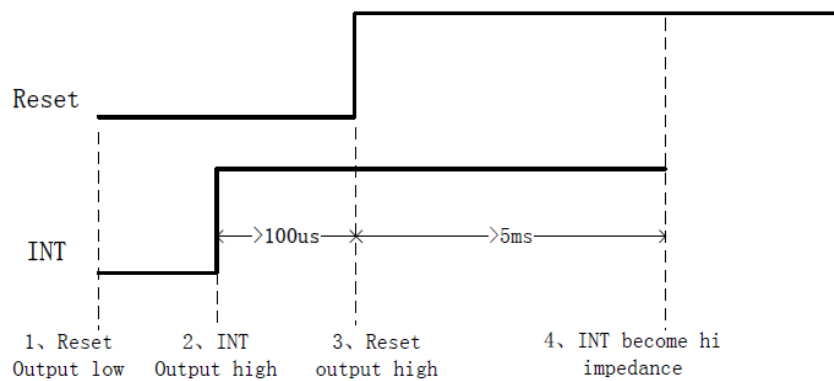

Fig.8(a) Timing of setting slave address

Timing of setting slave address to 0xBA/0xBB:

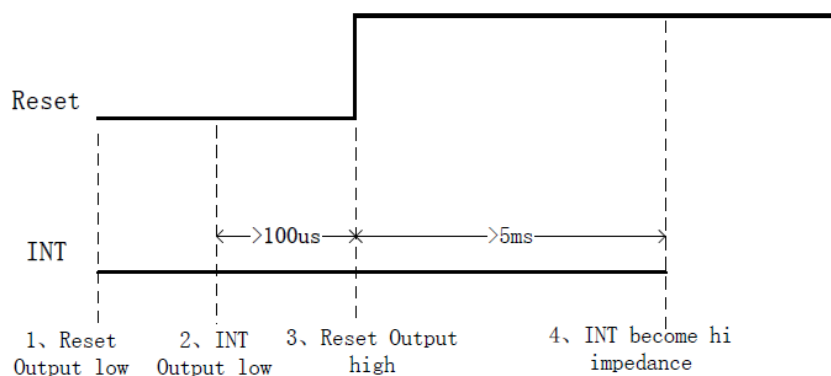

Fig.8(b) Timing of setting slave address

Data Transmission

(ex: slave address is 0xBA/0xBB)

Communication is always initiated by master, A high-to-low transition of SDA with SCL high is a start condition.

All addressing signal are serially transmitted to and from on bus in 8-bit word. This module sends a “0” to acknowledge when the addressing word is 0xBA/BB (or 0x28/0x29). This happens during the ninth clock cycle. If the slave address is not matched, this module will stay in idle state.

The data words are serially transmitted to and from in 9-bit formation: 8-bit data+1-bit ACK or NACK sent by module. Data changes during SCL low periods & keeps valid during SCL high.

A low-to-high transition of SDA with SCL high is a stop condition.

Write Data to module

(ex: slave address is 0xBA/0xBB)

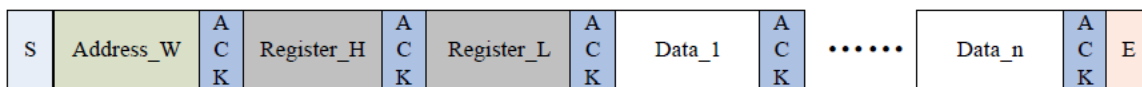

Please check the above figure, master start the communication first, and then sends device address 0xBA preparing for a write operation.

After receiving ACK from module, master sends out 16-bit register address, and then the data word in 8-bit, which is going to be wrote into module.

The address pointer of module will automatically increase one after one byte writing, so master can sequentially write in one operation. When operation finished, master stop the communication.

Read Data from module

(ex: slave address is 0xBA/0xBB)

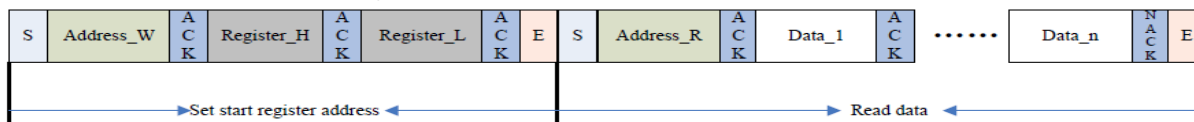

Please check the above figure, master start the communication first, and then sends device address 0xBA for a write operation.

After receiving ACK from module, master sends out 16-bit register address, to set the address pointer of module. After receiving ACK, master produce start signal once again & send device address 0xBB , then read data word from module in 8-bit.

Module also supports sequential read operation, and the default setting is sequential read mode. Master shall send out ACK after every byte reading successfully but NACK after the last one. Then sends stop signal to finish the communication.

9.2 REGISTER INFORMATION

a) Real Time Order

(Write Only)

Addr	Name	bit7	bit6	bit5	bit4	bit3	bit2	bit1	bit0
0x8040	Command	0: read coordinate 1: read diff data or raw data 2: software reset3:baseline update 4: baseline calibration 5: screen off 3&4 are still internal test							

b) Configuration Information

(R/W)

	Config Data	bit7	bit6	bit5	bit4	bit3	bit2	bit1	bit0
0x8047	Config_ Version	Version of the configuration							
0x8048	X Output Max (Low Byte)	Resolution of X axis							
0x8049	X Output Max (High Byte)								
0x804A	Y Output Max (Low Byte)	Resolution of Y axis							
0x804B	Y Output Max (High Byte)								
0x804C	Touch Number	Reserved				Touch number: 1~5			
0x804D	Module_Switch1	Reserved		Stretch_rank		X2Y	Reser ved		INT trigger method 00: rising edge trigger 01: falling edge trigger

					02: low level enquiry 03: high level enquiry
0x804E	Module_switch2	Reserved			
0x804F	Shake_Count	Reserved		Finger shake count	
0x8050	Filter	First_Filter	Normal_Filter (filtering value of original coordinate window, coefficient is 1)		
0x8051	Large_Touch	Number of touch in large area			
0x8052	Noise_Reduction	Reserved		Value of noise elimination (coefficient is 1, 0~15)	
0x8053	Screen_Touch_Level	Threshold of touch grow out of nothing			
0x8054	Screen_Leave_Level	Threshold of touch grow out of nothing			
0x8055	Low_Power_Control	Reserved		Time to low power consumption (0~15s)	
0x8056	Refresh_Rate	Reserved		Coordinate report rate (Cycle: 5+N ms)	
0x8057	x_threshold	Reserved			
0x8058	y_threshold				
0x8059	X_Speed_Limit	Reserved			
0x805A	Y_Speed_Limit				
0x805B	Space	Blank area of boarder-top (coefficient is 32)		Blank area of Boarder-bottom (coefficient is 32)	
0x805C		Blank area of boarder-left (coefficient is 32)		Blank area of Boarder-right (coefficient is 32)	
0x805D	Stretch_Rate	Reserved		Level of weak stretch (Stretch X/16 Pitch) (beta version is valid, published version is not)	
0x805E	Stretch_R0	Interval 1 coefficient			
0x805F	Stretch_R1	Interval 2 coefficient			
0x8060	Stretch_R2	Interval 3 coefficient			
0x8061	Stretch_RM	All intervals base number			
0x8062	Drv_GroupA_Num	All_Driving	Reserved	Driver_Group_A_number	
0x8063	Drv_GroupB_	Reserved		Driver_Group_B_number	

	Num				
0x8064	Sensor_Num	Sensor_Group_B_Number		Sensor_Group_A_Number	
0x8065	FreqA_factor	Driver frequency double frequency coefficient of Driver group A GroupA_Frequency = Multiplier factor * baseband			
0x8066	FreqB_factor	Driver frequency double frequency coefficient of Driver group B GroupB_Frequency = Multiplier factor * baseband			
0x8067	Pannel_BitFreqL	Baseband of Driver group A\B (1526HZ<baseband<14600Hz)			
0x8068	Pannel_BitFreqH				
0x8069	Pannel_Sensor_TimeL	Time interval of the neighbouring two driving signal (Unit: us), Reserved.			
0x806A	Pannel_Sensor_TimeH				
0x806B	Pannel_Tx_Gain	Reserved		Pannel_Drv_output_R 4 gears	Pannel_DAC_Gain 0:Gain maximum 7: Gain minimum
0x806C	Pannel_Rx_Gain	Pannel_PG_A_C	Pannel_PGA_R	Pannel_Rx_Vcmi (4 gears)	Pannel_PGA_Gain (8 gears)
0x806D	Pannel_Dump_Shift	Reserved		Magnification coefficient of original value (The Nth power of 2)	
0x806E	Drv_Frame_Control	Reserved	SubFrame_DrvNum		Repeat_Num
0x806F	NC	Reserved			
0x8070	NC	Reserved			
0x8071	NC	Reserved			
0x8072	Stylus_Tx_Gain	Undefined (invalid when stylus_priority=0)			
0x8073	Stylus_Rx_Gain	Undefined (invalid when stylus_priority=0)			
0x8074	Stylus_Dump_Shift	Magnification coefficient of original value (The Nth power of 2), Reserved			
0x8075	Stylus_Driver_Touch_Level	Stylus effective threshold (driving), Reserved			
0x8076	Stylus_Sensor_Touch_Level	Stylus effective threshold (sensing), Reserved			
0x8077	Stylus_Control	Pen mode escape time out period (Unit: Sec)			
0x8078	Base_reduce	S-Style improve quantity		Reserved	
0x8079	NC	Reserved			

0x807A	Freq_Hopping_Start	Frequency hopping start frequency (Unit: 2KHz, 50 means 100KHz)		
0x807B	Freq_Hopping_End	Frequency hopping stop frequency (Unit: 2KHz, 150 means 300KHz)		
0x807C	Noise_Detect_Times	Detect_Stay_Times	Detect_Confirm_Times	
0x807D	Hopping_Flag	Hopping_En	Reserved	Detect_Time_Out
0x807E	Hopping_Threshold	Large_Noise_Threshold		Hopping_Hit_Threshold
0x807F	Noise_Threshold	Threshold of noise level		
0x8080	NC	Reserved		
0x8081	NC	Reserved		
0x8082	Hopping_seg1_BitFreqL	Frequency hopping segment band 1 central frequency (for driver A/B)		
0x8083	Hopping_seg1_BitFreqH			
0x8084	Hopping_seg1_Factor	Frequency hopping segment 1 central frequency coefficient		
0x8085	Hopping_seg2_BitFreqL	Frequency hopping segment band 2 central frequency (for driver A/B)		
0x8086	Hopping_seg2_BitFreqH			
0x8087	Hopping_seg2_Factor	Frequency hopping segment 2 central frequency coefficient		
0x8088	Hopping_seg3_BitFreqL	Frequency hopping segment band 3 central frequency (for driver A/B)		
0x8089	Hopping_seg3_BitFreqH			
0x808A	Hopping_seg3_Factor	Frequency hopping segment 3 central frequency coefficient		
0x808B	Hopping_seg4_BitFreqL	Frequency hopping segment band 4 central frequency (for driver A/B)		
0x808C	Hopping_seg4_BitFreqH			

	BitFreqH		
0x808D	Hopping_seg4_Factor	Frequency hopping segment 4 central frequency coefficient	
0x808E	Hopping_seg5_BitFreqL	Frequency hopping segment band 5 central frequency (for driver A/B)	
0x808F	Hopping_seg5_BitFreqH		
0x8090	Hopping_seg5_Factor	Frequency hopping segment 5 central frequency coefficient	
0x8091	NC	Reserved	
0x8092	NC	Reserved	
0x8093	Key 1	Key 1 Position: 0-255 valid (0 means no touch, it means independent touch key when 4 of the keys are 8 multiples)	
0x8094	Key 2	Key 2 position	
0x8095	Key 3	Key 3 position	
0x8096	Key 4	Key 4 position	
0x8097	Key_Area	Time limit for long press(1~16 s)	Touch valid interval setting: 0-15 valid
0x8098	Key_Touch_Level	Key threshold of touch key	
0x8099	Key_Leave_Level	Key threshold of touch key	
0x809A	Key_Sens	KeySens_1(sensitivity coefficient of key 1, same below)	KeySens_2
0x809B	Key_Sens	KeySens_3	KeySens_4
0x809C	Key_Restrain	Finger from screen left after inhibition of key time(Unit:100ms,0 means 600ms)	The independent button pro key inhibition parameters
0x809D	NC	Reserved	
0x809E	NC	Reserved	
0x809F	NC	Reserved	
0x80A0	NC	Reserved	
0x80A1	NC	Reserved	
0x80A2	Proximity_Drv_Select	Drv_Start_Ch (start channel of driving direction)	Drv_End_Ch (End channel)
0x80A3	Proximity_Sens_Select	Sens_Start_Ch (start channel of sensing direction)	Sens_End_Ch (End channel)
0x80A4	Proximity_Touch_Level	Proximity effective threshold value	
0x80A5	Proximity_Leave_Level	Proximity ineffective threshold value	

0x80A6	Proximity_Sample_Add_Times	Frequency multiplication of proximity sensing channel.
0x80A7	Proximity_Sample_Dec_ValL	Sample value minus this value (16 bit), and accumulate, low byte.
0x80A8	Proximity_Sample_Dec_ValH	Sample value minus this value (16 bit), and accumulate, high byte.
0x80A9	Proximity_Leave_Shake_Count	exit proximity jitter count
0x80AA	Self_Cap_Tx_gain	self-capacitance sends gains
0x80AB	Self_Cap_Rx_gain	self-capacitance receive gains
0x80AC	Self_Cap_Dump_Shift	Magnification coefficient of original value of self-capacitance (The Nth power of 2)
0x80AD	SCap_Diff_Up_Level_Drv	Self capacitance suppress floating rising threshold (driving direction)
0x80AE	Scap_Merge_Touch_Level_Drv	Self-capacitance Touch Level (driving direction)
0x80AF	SCap_Pulse_TimeL	Self-capacitance sampling time (low byte)
0x80B0	SCap_Pulse_TimeH	Self-capacitance sampling time (high byte)
0x80B1	SCap_Diff_Up_Level_Sen	Self capacitance suppress floating rising threshold (sensing direction)
0x80B2	Scap_Merge_Touch_Level_Sen	Self-capacitance Touch Level (sensing direction)
0x80B3	NC	Reserved
0x80B4	NC	Reserved
0x80B5	NC	Reserved
0x80B6	NC	Reserved
0x80B7 ~ 0x80C4	Sensor_CH0~ Sensor_CH13	ITO Sensor corresponding chip channel number
0x80C5 ~ 0x80D4	NC	Reserved
0x80D5 ~ 0x80EE	Driver_CH0~ Driver_CH25	ITO Driver corresponding chip channel number
0x80EF ~	NC	Reserved

0x80FE		
0x80FF	Config_Chksum	configuration information verify (the complement number of total byte from 0x8047 to 0x80FE)
0x8100	Config_Fresh	signal of updated configuration (the host writes)

c) Coordinates Information

Addr	Access	bit7	bit6	bit5	bit4	bit3	bit2	bit1	bit0
0x8140	R	Product ID (first byte, ASCII)							
0x8141	R	Product ID (second byte, ASCII)							
0x8142	R	Product ID (third byte, ASCII)							
0x8143	R	Product ID (forth byte, ASCII)							
0x8144	R	Firmware version (HEX.low byte)							
0x8145	R	Firmware version (HEX.high byte)							
0x8146	R	x coordinate resolution (low byte)							
0x8147	R	x coordinate resolution (high byte)							
0x8148	R	y coordinate resolution (low byte)							
0x8149	R	y coordinate resolution (high byte)							
0x814A	R	Vendor_id (current module option information)							
0x814B	R	Reserved							
0x814C	R	Reserved							
0x814D	R	Reserved							
0x814E	R/W	buffer status	large detect	Reserved			number of touch points		
0x814F	R	track id							
0x8150	R	point 1 x coordinate (low byte)							
0x8151	R	point 1 x coordinate (high byte)							
0x8152	R	point 1 y coordinate (low byte)							
0x8153	R	point 1 y coordinate (high byte)							
0x8154	R	Point 1 size (low byte)							
0x8155	R	point 1 size (high byte)							
0x8156	R	Reserved							
0x8157	R	track id							
0x8158	R	point 2 x coordinate (low byte)							
0x8159	R	point 2 x coordinate (high byte)							
0x815A	R	point 2 y coordinate (low byte)							
0x815B	R	point 2 y coordinate (high byte)							
0x815C	R	point 2 size (low byte)							
0x815D	R	point 2 size (high byte)							
0x815E	R	Reserved							

0x815F	R	track id
0x8160	R	point 3 x coordinate (low byte)
0x8161	R	point 3 x coordinate (high byte)
0x8162	R	point 3 y coordinate (low byte)
0x8163	R	point 3 y coordinate (high byte)
0x8164	R	point 3 size (low byte)
0x8165	R	point 3 size (high byte)
0x8166	R	Reserved
0x8167	R	track id
0x8168	R	point 4 x coordinate (low byte)
0x8169	R	point 4 x coordinate (high byte)
0x816A	R	point 4 y coordinate (low byte)
0x816B	R	point 4 y coordinate (high byte)
0x816C	R	point 4 size (low byte)
0x816D	R	point 4 size (high byte)
0x816E	R	Reserved
0x816F	R	track id
0x8170	R	point 5 x coordinate (low byte)
0x8171	R	point 5 x coordinate (high byte)
0x8172	R	point 5 y coordinate (low byte)
0x8173	R	point 5 y coordinate (high byte)
0x8174	R	point 5 size (low byte)
0x8175	R	point 5 size (high byte)
0x8176	R	Reserved
0x8177	R	Reserved

9.3 FUNCTION MODE

Working Mode

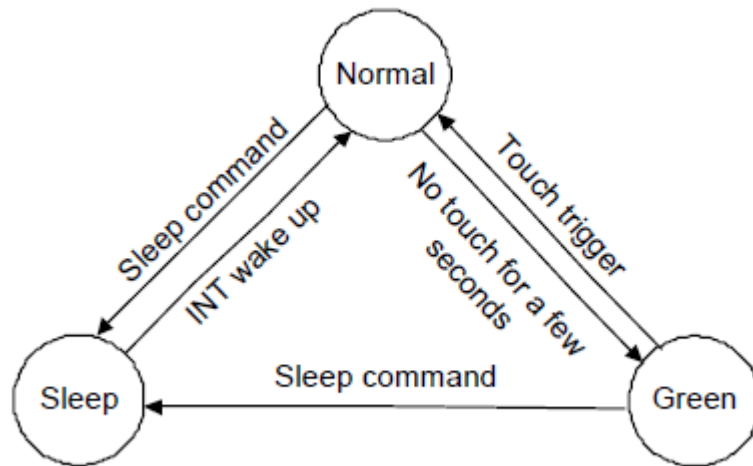

a) Normal Mode

When module is in Normal mode, touch scanning period is about 7ms ~ 10ms depending on the setting. The chip will automatically enter into Green mode if no touch for short time within 0~15s depending on setting and the step is 1s.

b) Green Mode

In Green mode, the touch scanning cycle is fixed as 40ms. It will automatically enter into Normal mode if any touch is detected.

c) Sleep Mode

For a lower consumption, Master can ask module to enter Sleep mode through I2C command (before the command, please drive low to INT pin). Drive high to the INT pin of module 2~5ms will make module return back to normal mode.

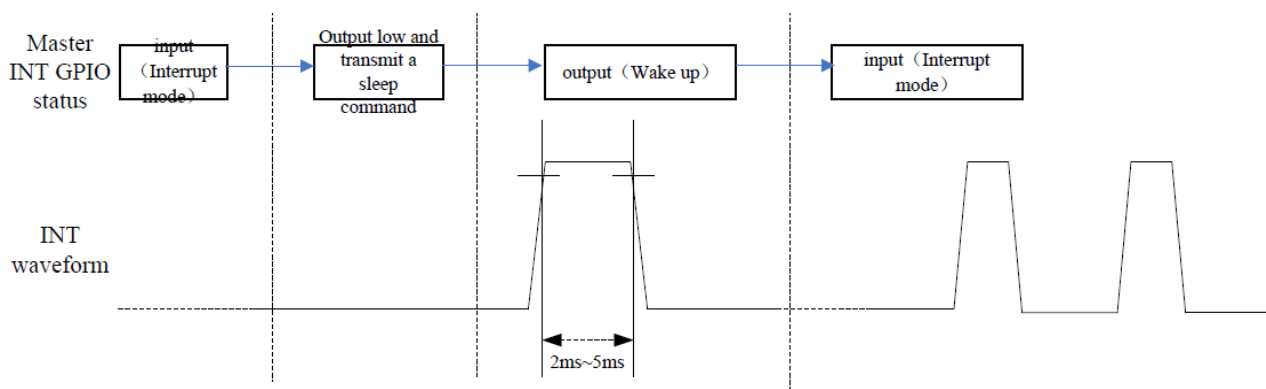

Pulse Calling

Module will inform master to read coordinate information only when touch event happen, in order to lighten the burden of master CPU. The master CPU will set trigger mode by register "INT". "0" means rising edge trigger, in this mode module will output a rising edge hopping in INT, to inform CPU; "1" means falling edge trigger.

Sleep Mode

When the display is turned off or in any circumstance that operation of touch panel is not necessary, master can set module be in Sleep mode through I2C command. The master can wake up module by outputting high to INT pin & keeping 2-5ms.

Frequency Hopping Function

This module has very strong anti-interference hardware, when the driver spectrum of module overlaid with spectrum of noise signal, it can be switch to another frequency by self-adaption frequency hopping mechanism, to avoid interference.

Automatic Calibration

a) Initialization Calibration

Different temperature, humidity and physical structure will affect the sensor's baseline. According to environmental situation module will update the baseline automatically in initialized 200ms.

b) Automatic Temperature Drift

Slow change of temperature, humidity or dust and other environmental factors will also affect the sensor's baseline module calculates and analyses historical data, and compare to the current data variation. Base on this, the baseline will be calibration automatically.

For more information, refer to the data sheet GT911:

https://www.lcd-module.de/fileadmin/eng/pdf/zubehoer/GT911%20Datasheet_English%2020150625_Rev10.pdf.

10. STANDARD SPECIFICATION FOR RELIABILITY

10.1 STANDARD SPECIFICATION FOR RELIABILITY OF LCD MODULE

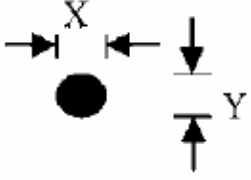
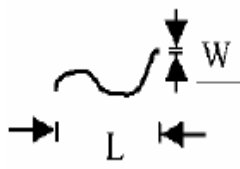
NO.	Item	Criterion	AQL												
01	Electrical Testing	1.1 Missing vertical, horizontal segment, segment contrast defect. 1.2 Missing character, dot or icon. 1.3 Display malfunction. 1.4 No function or no display. 1.5 Current consumption exceeds product specifications. 1.6 LCD viewing angle defect. 1.7 Mixed product types. 1.8 Flicker	0.65												
02	Black or White spots or Bright spots or Color spots on LCD (Display only)	2.1 White and black or color spots on display $\leq 0.25\text{mm}$, no more than Five spots. 2.2 Densely spaced: No more than three spots within 3mm.	1.5												
03	LCD and Touch Panel black spots, white spots, contamination (non – display)	3.1 Round type: As following drawing $\Phi = (X+Y) / 2$ <table border="1" style="margin-left: auto; margin-right: auto;"> <thead> <tr> <th>Size(mm)</th> <th>Acceptable Q'ty</th> </tr> </thead> <tbody> <tr> <td>$\Phi \leq 0.10$</td> <td>Accept no dense</td> </tr> <tr> <td>$0.10 < \Phi \leq 0.20$</td> <td>2</td> </tr> <tr> <td>$0.20 < \Phi \leq 0.25$</td> <td>2</td> </tr> <tr> <td>$0.25 < \Phi \leq 0.30$</td> <td>1</td> </tr> <tr> <td>$0.30 < \Phi$</td> <td>0</td> </tr> </tbody> </table>  <p style="text-align: center;">* Densely spaced: No more than two spots within 3mm.</p>	Size(mm)	Acceptable Q'ty	$\Phi \leq 0.10$	Accept no dense	$0.10 < \Phi \leq 0.20$	2	$0.20 < \Phi \leq 0.25$	2	$0.25 < \Phi \leq 0.30$	1	$0.30 < \Phi$	0	1.5
		Size(mm)	Acceptable Q'ty												
$\Phi \leq 0.10$	Accept no dense														
$0.10 < \Phi \leq 0.20$	2														
$0.20 < \Phi \leq 0.25$	2														
$0.25 < \Phi \leq 0.30$	1														
$0.30 < \Phi$	0														
3.2 Line type: (As following drawing) <table border="1" style="margin-left: auto; margin-right: auto;"> <thead> <tr> <th>Length(m)</th> <th>Width(mm)</th> <th>Acceptable Q'ty</th> </tr> </thead> <tbody> <tr> <td>---</td> <td>$W \leq 0.02$</td> <td>Accept no dense</td> </tr> <tr> <td>$L \leq 3.0$</td> <td>$0.02 < W \leq 0.05$</td> <td rowspan="2">2</td> </tr> <tr> <td>$L \leq 2.5$</td> <td>$0.03 < W \leq 0.08$</td> </tr> <tr> <td>---</td> <td>$0.08 < W$</td> <td>Rejection</td> </tr> </tbody> </table>  <p style="text-align: center;">* Densely spaced: No more than two lines within 3mm.</p>	Length(m)	Width(mm)	Acceptable Q'ty	---	$W \leq 0.02$	Accept no dense	$L \leq 3.0$	$0.02 < W \leq 0.05$	2	$L \leq 2.5$	$0.03 < W \leq 0.08$	---	$0.08 < W$	Rejection	1.5
Length(m)	Width(mm)	Acceptable Q'ty													
---	$W \leq 0.02$	Accept no dense													
$L \leq 3.0$	$0.02 < W \leq 0.05$	2													
$L \leq 2.5$	$0.03 < W \leq 0.08$														
---	$0.08 < W$	Rejection													

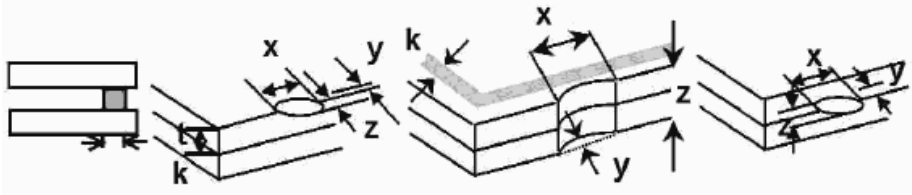
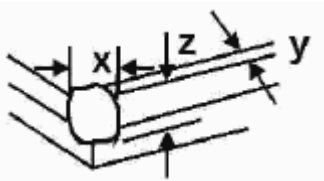
NO.	Item	Criterion	AQL																		
04	Polarizer bubbles	<p>If bubbles are visible, judge using black spot specifications, not easy to find, must check in specify direction</p> <table border="1" data-bbox="922 495 1386 741"> <thead> <tr> <th>Size Φ(mm)</th> <th>Acceptable Q'ty</th> </tr> </thead> <tbody> <tr> <td>$\Phi \leq 0.20$</td> <td>Accept no dense</td> </tr> <tr> <td>$0.20 < \Phi \leq 0.50$</td> <td>3</td> </tr> <tr> <td>$0.50 < \Phi \leq 1.00$</td> <td>2</td> </tr> <tr> <td>$1.00 < \Phi$</td> <td>0</td> </tr> <tr> <td>Total Q'ty</td> <td>3</td> </tr> </tbody> </table>	Size Φ (mm)	Acceptable Q'ty	$\Phi \leq 0.20$	Accept no dense	$0.20 < \Phi \leq 0.50$	3	$0.50 < \Phi \leq 1.00$	2	$1.00 < \Phi$	0	Total Q'ty	3	1.5						
Size Φ (mm)	Acceptable Q'ty																				
$\Phi \leq 0.20$	Accept no dense																				
$0.20 < \Phi \leq 0.50$	3																				
$0.50 < \Phi \leq 1.00$	2																				
$1.00 < \Phi$	0																				
Total Q'ty	3																				
05	Scratches	Follow NO.3 -2 Line Type.																			
06	Chipped glass	<p>Symbols: x: Chip length y: Chip width z: Chip thickness k: Seal width t: Glass thickness a: LCD side length L: Electrode pad length</p> <p>6.1 General glass chip: 6.1.1 Chip on panel surface and crack between panels:</p>  <table border="1" data-bbox="411 1256 1230 1368"> <thead> <tr> <th>z: Chip thickness</th> <th>y: Chip width</th> <th>x: Chip length</th> </tr> </thead> <tbody> <tr> <td>$Z \leq 1/2t$</td> <td>Not over viewing area</td> <td>$x \leq 1/8a$</td> </tr> <tr> <td>$1/2t < z \leq 2t$</td> <td>Not exceed 1/3k</td> <td>$x \leq 1/8a$</td> </tr> </tbody> </table> <p>⊙ Unit: mm ⊙ If there are 2 or more chips, x is the total length of each chip</p> <p>6.1.2 Corner crack:</p>  <table border="1" data-bbox="411 1704 1230 1816"> <thead> <tr> <th>z: Chip thickness</th> <th>y: Chip width</th> <th>x: Chip length</th> </tr> </thead> <tbody> <tr> <td>$Z \leq 1/2t$</td> <td>Not over viewing area</td> <td>$x \leq 1/8a$</td> </tr> <tr> <td>$1/2t < z \leq 2t$</td> <td>Not exceed 1/3k</td> <td>$x \leq 1/8a$</td> </tr> </tbody> </table> <p>⊙ Unit: mm ⊙ If there are 2 or more chips, x is the total length of each chip</p>	z: Chip thickness	y: Chip width	x: Chip length	$Z \leq 1/2t$	Not over viewing area	$x \leq 1/8a$	$1/2t < z \leq 2t$	Not exceed 1/3k	$x \leq 1/8a$	z: Chip thickness	y: Chip width	x: Chip length	$Z \leq 1/2t$	Not over viewing area	$x \leq 1/8a$	$1/2t < z \leq 2t$	Not exceed 1/3k	$x \leq 1/8a$	1.5
z: Chip thickness	y: Chip width	x: Chip length																			
$Z \leq 1/2t$	Not over viewing area	$x \leq 1/8a$																			
$1/2t < z \leq 2t$	Not exceed 1/3k	$x \leq 1/8a$																			
z: Chip thickness	y: Chip width	x: Chip length																			
$Z \leq 1/2t$	Not over viewing area	$x \leq 1/8a$																			
$1/2t < z \leq 2t$	Not exceed 1/3k	$x \leq 1/8a$																			

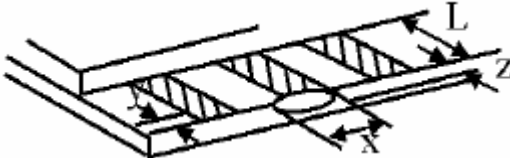
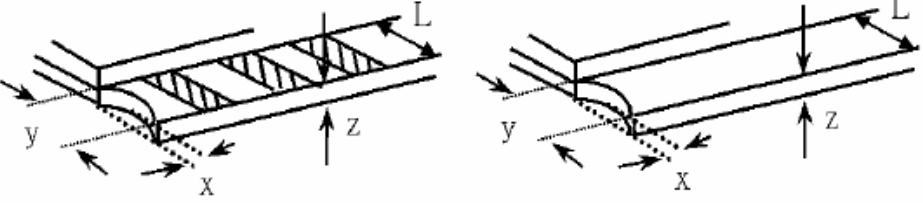
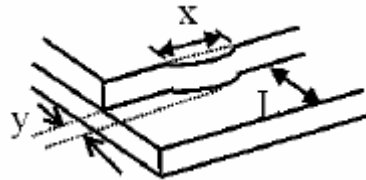
NO.	Item	Criterion	AQL																
07	Glass crack	<p>Symbols: x: Chip length y: Chip width z: Chip thickness k: Seal width t: Glass thickness a: LCD side length L: Electrode pad length</p> <p>7.2 Protrusion over terminal: 7.2.1 Chip on electrode pad:</p>  <table border="1" data-bbox="574 766 1251 913"> <tr> <td>y: Chip width</td> <td>x: Chip length</td> <td>z: Chip thickness</td> </tr> <tr> <td>$y \leq 0.5\text{mm}$</td> <td>$x \leq 1/8a$</td> <td>$0 < z \leq t$</td> </tr> </table> <p>7.2.2 Non-conductive portion:</p>  <table border="1" data-bbox="574 1258 1251 1406"> <tr> <td>y: Chip width</td> <td>x: Chip length</td> <td>z: Chip thickness</td> </tr> <tr> <td>$y \leq L$</td> <td>$x \leq 1/8a$</td> <td>$0 < z \leq t$</td> </tr> </table> <p>⊙ If there chipped area touches the ITO terminal, over 2/3 of the ITO must remain and be inspected according to electrode terminal specifications. ⊙ If the product will be heat sealed by the customer, the alignment mark must not be damaged.</p> <p>7.2.3 Substrate protuberance and internal crack</p>  <table border="1" data-bbox="906 1653 1340 1800"> <tr> <td>y: width</td> <td>x: length</td> </tr> <tr> <td>$y \leq 1/3L$</td> <td>$X \leq a$</td> </tr> </table>	y: Chip width	x: Chip length	z: Chip thickness	$y \leq 0.5\text{mm}$	$x \leq 1/8a$	$0 < z \leq t$	y: Chip width	x: Chip length	z: Chip thickness	$y \leq L$	$x \leq 1/8a$	$0 < z \leq t$	y: width	x: length	$y \leq 1/3L$	$X \leq a$	1.5
y: Chip width	x: Chip length	z: Chip thickness																	
$y \leq 0.5\text{mm}$	$x \leq 1/8a$	$0 < z \leq t$																	
y: Chip width	x: Chip length	z: Chip thickness																	
$y \leq L$	$x \leq 1/8a$	$0 < z \leq t$																	
y: width	x: length																		
$y \leq 1/3L$	$X \leq a$																		

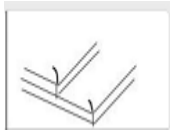
NO.	Item	Criterion	AQL
08	Cracked glass	The LCD with any extensive crack is not acceptable. 	1.5
09	Backlight elements	9.1 Illumination source flickers when lit. 9.2 Spots or scratches that appear when lit must be judged. Using LCD spot, lines and contamination standards. 9.3 Backlight doesn't light or color is wrong.	1.5 1.5 0.65
10	Bezel	Bezel must comply with product specifications.	1.5
11	PCB、COB	11.1 COB seal may not have pinholes larger than 0.2mm or contamination. 11.2 COB seal surface may not have pinholes through to the IC. 11.3 The height of the COB should not exceed the height indicated in the assembly diagram. 11.4 There may not be more than 2mm of sealant outside the seal area on PCB. And there should be no more than three places. 11.5 Parts on PCB must be the same as on the production characteristic chart, There should be no wrong parts, missing parts or excess parts. 11.6 The jumper on the PCB should conform to the product characteristic chart.	1.5 1.5 1.5 1.5 0.65 0.65
12	FPC	12.1 FPC terminal damage \leq 1/2 FPC terminal width and can not affect the function , we judge accept. 12.2 FPC alignment hole damage \leq 1/2 alignment area and can not affect the function , we judge accept.	1.5 1.5
13	Soldering	13.1 No cold solder joints, missing solder connections, oxidation or icicle. 13.2 No short circuits in components on PCB or FPC.	1.5 0.65

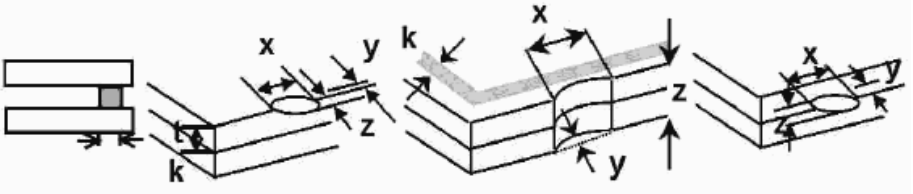
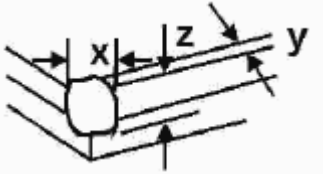
NO.	Item	Criterion	AQL												
14	Touch Panel Chipped glass	<p>Symbols: x: Chip length y: Chip width z: Chip thickness k: Seal width t: Touch Panel Total thickness a: LCD side length L: Electrode pad length</p> <p>14.1 General glass chip: 14.1.1 Chip on panel surface and crack between panels:</p>  <table border="1" data-bbox="464 775 1286 990"> <tr> <td>z: Chip thickness</td> <td>y: Chip width</td> <td>x: Chip length</td> </tr> <tr> <td>$z \leq t$</td> <td>$\leq 1/2 k$ and not over viewing area</td> <td>$x \leq 1/8a$</td> </tr> </table> <p>⊙ Unit: mm ⊙ If there are 2 or more chips, x is the total length of each chip</p> <p>14.1.2 Corner crack:</p>  <table border="1" data-bbox="464 1323 1286 1538"> <tr> <td>z: Chip thickness</td> <td>y: Chip width</td> <td>x: Chip length</td> </tr> <tr> <td>$z \leq t$</td> <td>$\leq 1/2 k$ and not over viewing area</td> <td>$x \leq 1/8a$</td> </tr> </table> <p>⊙ Unit: mm ⊙ If there are 2 or more chips, x is the total length of each chip</p>	z: Chip thickness	y: Chip width	x: Chip length	$z \leq t$	$\leq 1/2 k$ and not over viewing area	$x \leq 1/8a$	z: Chip thickness	y: Chip width	x: Chip length	$z \leq t$	$\leq 1/2 k$ and not over viewing area	$x \leq 1/8a$	1.5
z: Chip thickness	y: Chip width	x: Chip length													
$z \leq t$	$\leq 1/2 k$ and not over viewing area	$x \leq 1/8a$													
z: Chip thickness	y: Chip width	x: Chip length													
$z \leq t$	$\leq 1/2 k$ and not over viewing area	$x \leq 1/8a$													

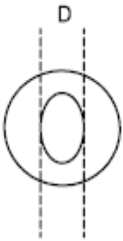
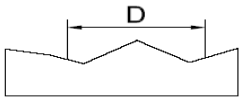
NO.	Item	Criterion	AQL										
15	Touch Panel(Fish eye, dent and bubble on film)	<table border="1"> <thead> <tr> <th>SIZE(mm)</th> <th>Acceptable Q'ty</th> </tr> </thead> <tbody> <tr> <td>$\Phi \leq 0.2$</td> <td>Accept no dense</td> </tr> <tr> <td>$0.2 < D \leq 0.4$</td> <td>5</td> </tr> <tr> <td>$0.4 < D \leq 0.5$</td> <td>2</td> </tr> <tr> <td>$0.5 < D$</td> <td>0</td> </tr> </tbody> </table>  	SIZE(mm)	Acceptable Q'ty	$\Phi \leq 0.2$	Accept no dense	$0.2 < D \leq 0.4$	5	$0.4 < D \leq 0.5$	2	$0.5 < D$	0	1.5
SIZE(mm)	Acceptable Q'ty												
$\Phi \leq 0.2$	Accept no dense												
$0.2 < D \leq 0.4$	5												
$0.4 < D \leq 0.5$	2												
$0.5 < D$	0												
16	Touch Panel Newton ring	Newton ring dimension $\leq 1/2$ touch panel area and not affect font and line distortion($\leq 2.5\%$), it is acceptable.	1.5										
17	Touch Panel Linearity	Less than 2.5% is acceptable.	1.5										
18	LCD Ripple	Touch the touch panel, can not see the LCD ripple. Pen: R 1.0mm silicon rubber. Operation Force: 80g	1.5										
19	General appearance	19.1 Pin type must match type in specification sheet. 19.2 LCD pin loose or missing pins. 19.3 Product packaging must the same as specified on packaging specification sheet. 19.4 Product dimension and structure must conform to product specification sheet.	0.65 0.65 0.65 0.65										

10.2 TESTING CONDITIONS AND INSPECTION CRITERIA

For the final test, the testing sample must be stored at room temperature for 24 hours. After the tests listed in table below, standard specifications for reliability will be executed in order to ensure stability.

No.	Item	Test Model	In section Criteria
01	Current Consumption	Refer to Specification	The current consumption should conform to the product specification.
02	Contrast	Refer to Specification	After the tests have been executed, the contrast must be larger than half of its initial value prior to the tests.
03	Appearance	Visual inspection	Defect free.

10.3 MTBF

MTBF	Functions, performance, appearance, etc. shall be free from remarkable deterioration within 50,000 hours under ordinary operating and storage conditions room temperature ($25\pm 5^{\circ}\text{C}$), normal humidity ($50\pm 10\%$ RH), and in area not exposed to direct sun light.
------	---

11. SPECIFICATION OF QUALITY ASSURANCE

This standard of Quality Assurance confirms to the quality of LCD module products supplied by ELECTRONIC ASSEMBLY.

11.1 QUALITY TEST

Before delivering, the supplier should conduct the following tests to confirm the quality of products.

Electrical-Optical Characteristics: According to the individual specification to test the product.

Appearance Characteristics: According to the individual specification to test the product.

Reliability Characteristics: According to the definition of reliability on the specification for testing products.

11.2 DELIVERY TEST

Before delivering, the supplier should conduct the delivery test.

Test method: According to MIL-STD105E. General Inspection Level II take a single Time.

The defects classify of AQL as following:

Major defect: AQL = 0.65

Minor defect: AQL = 1.5

Total defects: AQL = 1.5

11.3 NON-CONFORMING ANALYSIS & DEAL WITH MANNERS

11.3.1 NON-CONFORMING ANALYSIS

Purchaser should provide the data detail of non-conforming sample and the non-conforming.

After receiving the data detail from purchaser, the analysis of non-conforming should be finished within two weeks.

If the analysis can't be finished on time, supplier must notice purchaser 3 days in advance.

11.3.2 DISPOSITION OF NON-CONFORMING

If any product defect be found during assembling, supplier must change the good for every defect after confirmation.

Both supplier and customer should analyze the reason and discuss the disposition of non-conforming when the reason of nonconforming is not sure.

11.4 AGREEMENT ITEMS

Both parties should negotiate together when the following problems happen.
There is any problem of standard of quality assurance, and both sides should agree that it must be modified.

There is any argument item which does not record in the standard of quality assurance.

Any other special problem.

11.5 STANDARD OF THE PRODUCT APPEARANCE TEST

11.5.1 MANNER OF APPEARANCE TEST

The test must be under 20W × 2 or 40W fluorescent light, and the distance of view must be at 30±5cm.

When test the model of transmissive product must add the reflective plate.

The test direction is base on around 10° of vertical line.

Temperature: 25±5°C Humidity: 60±10%RH

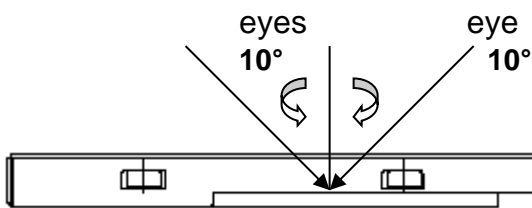

Definition of area:

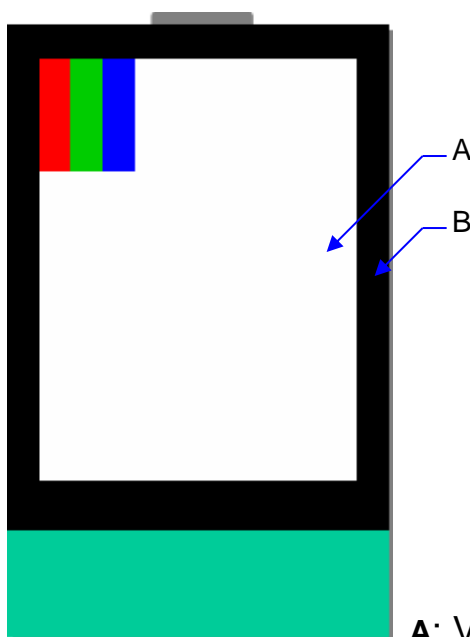

A: Viewing area B: Outside viewing area

11.5.2 BASIC PRINCIPLE

When the standard can not be described, AQL will be applied.

The sample of the lowest acceptable quality level must be negotiated by both supplier and customer when any dispute happened.

New item must be added on time when it is necessary.

12. HANDLING PRECAUTION

12.1 HANDLING OF LCM

- Avoid external shock.
- Don't apply excessive force on the surface.
- Liquid in LCD is hazardous substance, do not lick or swallow. When the liquid is attaching to your hand, skin, cloth, etc., wash it thoroughly and immediately.
- Don't operate it above the absolute maximum rating.
- Don't disassemble the LCM.
- The operators should wear protections whenever he/she comes into contact with the module. Never touch any of the conductive parts such as the LSI pads, the copper leads on the PCB and the interface terminals with any parts of the human body.
- The modules should be kept in antistatic bags or other containers resistant to static for storage.
- The module is coated with a film to protect the display surface, be careful when peeling off this protective film since static electricity may be generated.

12.2 STORAGE

- Store it in an ambient temperature of $25\pm 10^{\circ}\text{C}$, and in a relative humidity of $50\pm 10\%\text{RH}$. Don't expose to sunlight or fluorescent light.
- Store it in a clean environment, free from dust, active gas, and solvent.
- Store it in anti-static electricity container.
- Store it without any physical load.

12.3 SOLDERING

- Use only soldering irons with proper grounding and no leakage.
- Iron: not higher than $280\pm 10^{\circ}\text{C}$ and less than 3 sec during hand soldering.
- Rewiring: not more than 2 times.

13. INITIALISATION EXAMPLE RGB565

```

SPI_WriteComm(0x11); //Sleep Out
Delay(150);
SPI_WriteComm(0xB9); //SET password
SPI_WriteData(0xFF);
SPI_WriteData(0x83);
SPI_WriteData(0x57);
SPI_WriteComm(0xB1); //SETPower
SPI_WriteData(0x00); //STB
SPI_WriteData(0x16); //
SPI_WriteData(0x1C); //VSPR = 4.41V
SPI_WriteData(0x1C); //VSNR = -4.41V
SPI_WriteData(0xC3); //AP 0xc3
SPI_WriteData(0x5C); //FS 0x44

SPI_WriteComm(0xB3);
SPI_WriteData(0x43);
SPI_WriteData(0x00);
SPI_WriteData(0x06);
SPI_WriteData(0x06);

SPI_WriteComm(0xB4); //SETCYC
SPI_WriteData(0x32); //2-dot
SPI_WriteData(0x40); //RTN
SPI_WriteData(0x00); //DIV
SPI_WriteData(0x2A); //N_DUM
SPI_WriteData(0x2A); //I_DUM
SPI_WriteData(0x0D); //GDON
SPI_WriteData(0x78); //GDOFF
SPI_WriteComm(0xB6); //VCOMDC
SPI_WriteData(0x3c);
SPI_WriteComm(0xB5);
SPI_WriteData(0x0B); //08
SPI_WriteData(0x0B); //08

SPI_WriteComm(0xC0); //SETSTBA
SPI_WriteData(0x70); //N_OPON
SPI_WriteData(0x50); //I_OPON
SPI_WriteData(0x01); //STBA
SPI_WriteData(0x3C); //STBA
SPI_WriteData(0xC8); //STBA
SPI_WriteData(0x08); //GENON
SPI_WriteComm(0xCC); //Set Panel
SPI_WriteData(0x0B);
SPI_WriteComm(0xB6); //VCOMDC
SPI_WriteData(0x40); //0x40

SPI_WriteComm(0xE0); //Set Gamma
SPI_WriteData(0x02);
SPI_WriteData(0x0A);
SPI_WriteData(0x10);
SPI_WriteData(0x1A);
SPI_WriteData(0x22);
SPI_WriteData(0x34);
SPI_WriteData(0x41);
SPI_WriteData(0x4A);
SPI_WriteData(0x4D);
SPI_WriteData(0x44);
SPI_WriteData(0x3A);
SPI_WriteData(0x23);
SPI_WriteData(0x19);
SPI_WriteData(0x08);
SPI_WriteData(0x09);
SPI_WriteData(0x03);
SPI_WriteData(0x02);
SPI_WriteData(0x0A);
SPI_WriteData(0x10);
SPI_WriteData(0x1A);
SPI_WriteData(0x22);
SPI_WriteData(0x34);
SPI_WriteData(0x41);
SPI_WriteData(0x4A);
SPI_WriteData(0x4D);

```

```
SPI_WriteData(0x44);
SPI_WriteData(0x3A);
SPI_WriteData(0x23);
SPI_WriteData(0x19);
SPI_WriteData(0x08);
SPI_WriteData(0x09);
SPI_WriteData(0x03);
SPI_WriteData(0x00);
SPI_WriteData(0x01);

SPI_WriteComm(0xB4); //Display cycle register
SPI_WriteData(0x00); //Z-inversion disable, Column inversion

SPI_WriteComm(0xB5); //SetBGP (TRI=0)
SPI_WriteData(0x03); //Vref = 4.4V
SPI_WriteData(0x03); //nVREF = 4.4 V
SPI_WriteData(0x03); //VPP = 7.5 V, VDHS = 5.26 V

SPI_WriteComm(0xB6);
SPI_WriteData(0xB0);
SPI_WriteData(0x22);
SPI_WriteData(0x3B);

SPI_WriteComm(0x3A); //COLMOD
SPI_WriteData(0x55); //RGB565
SPI_WriteComm(0x11); //Sleep out
SPI_WriteComm(0x13); //Normal display mode
SPI_WriteComm(0x29); //Display On
```