

Features:

- Good anti-surge capability
- Wirewound on ceramic element
- RoHS compliant, lead free and halogen free



Electrical Specifications

Type / Code	Element Power Rating (W) @ 70°C	Element + Fuse Power Rating (W) @ 70°C	Rated Functioning Temperature (°C)	Fusing Current (A)	TCR (ppm/°C)	Ohmic Range (Ω) and Tolerance
						5%
RWT2	2	1.5	142	2	± 200	1 - 100
RWT5	5	1.6				1 - 470
RWT7	7	2				1 - 470

Max Voltage Rating = $\sqrt{P \cdot R}$

Mechanical Specifications

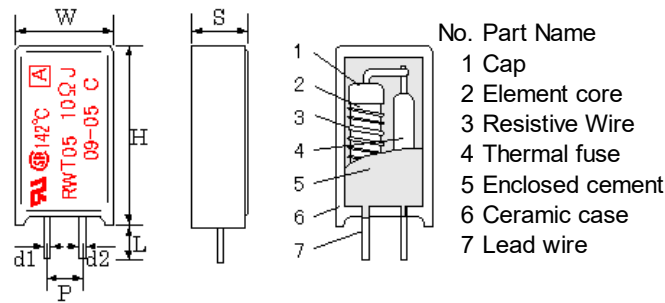

Type / Code	W	H	S	L	P	d1	d2	Unit
RWT2	0.433 ± 0.020	0.807 ± 0.059	0.276 ± 0.039	0.197 ± 0.020	0.197 ± 0.039	0.024 ± 0.002	0.031 ± 0.002	inches
	11.00 ± 0.50	20.50 ± 1.50	7.00 ± 1.00	5.00 ± 0.50	5.00 ± 1.00	0.60 ± 0.05	0.80 ± 0.05	mm
RWT5	0.512 ± 0.039	0.984 ± 0.059	0.374 ± 0.039	0.197 ± 0.020	0.197 ± 0.039	0.024 ± 0.002	0.031 ± 0.002	inches
	13.00 ± 1.00	25.00 ± 1.50	9.50 ± 1.00	5.00 ± 0.50	5.00 ± 1.00	0.60 ± 0.05	0.80 ± 0.05	mm
RWT7	0.512 ± 0.039	1.535 ± 0.059	0.374 ± 0.039	0.197 ± 0.020	0.197 ± 0.039	0.024 ± 0.002	0.031 ± 0.002	inches
	13.00 ± 1.00	39.00 ± 1.50	9.50 ± 1.00	5.00 ± 0.50	5.00 ± 1.00	0.60 ± 0.05	0.80 ± 0.05	mm

Performance Characteristics

Test	Test Method	Test Results
Short Time Overload	Apply DV voltage of 2.5 times the rated voltage for 5 seconds.	± 2%
Load Life	Apply rated DC voltage for 1.5 hour ON and 0.5 hour OFF. Total time of 1000 hours.	± 3%
Humidity Test (no load)	Temperature of 40°C. Humidity of 90 - 95% RH. Total time of 1000 hours.	± 2%
Humidity Test (rated load)	Temperature of 40°C. Humidity of 90 - 95% RH. Apply 1/10 rated power for 1.5 hour ON and 0.5 hour OFF. Total time of 1000 hours.	± 2%
Resistance to Soldering Heat	Dip lead into solder bath at temperature of 260°C x 10°C up to 1.5 mm from the body of the resistor. Leave in solder bath for 10 seconds. Test after 24 hours in room temperature.	± 1%
Solderability	> 95% coverage	
Insulation Resistance	R < 1 G Ω	

Operating Temperature Range : -25°C to +100°C

Fusing Characteristics:

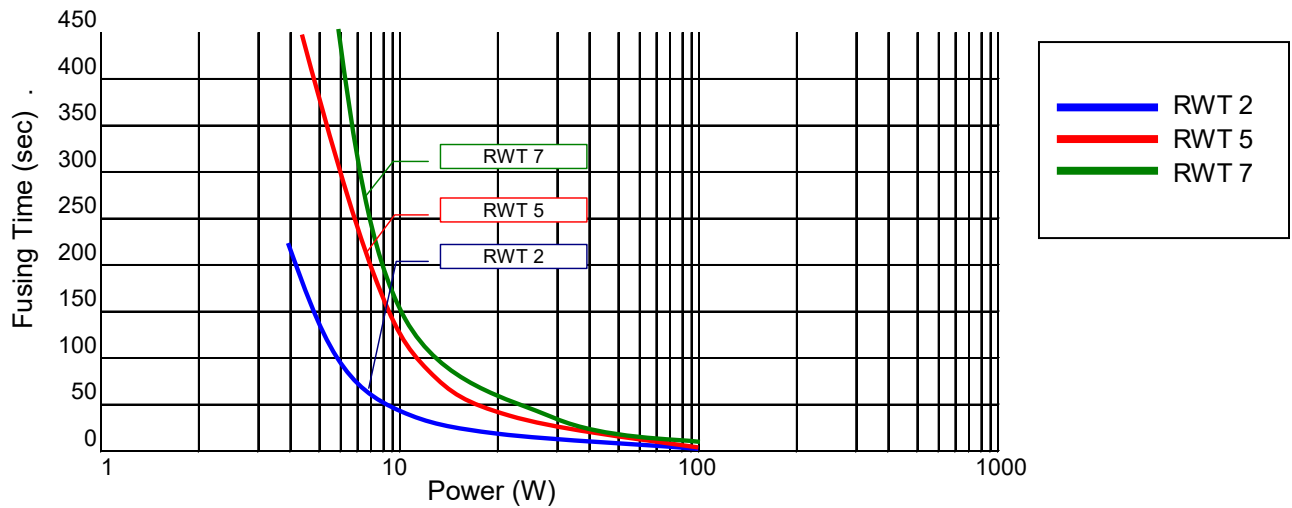

Recommended Solder Profile

This information is intended as a reference for solder profiles for Stackpole resistive components. These profiles should be compatible with most soldering processes. These are only recommendations. Actual numbers will depend on board density, geometry, packages used, etc., especially those cells labeled with “**”.

100% Matte Tin / RoHS Compliant Terminations

Soldering iron recommended temperatures: 330°C to 350°C with minimum duration.
Maximum number of reflow cycles: 3.

Wave Soldering			
Description	Maximum	Recommended	Minimum
Preheat Time	80 seconds	70 seconds	60 seconds
Temperature Diff.	140°C	120°C	100°C
Solder Temp.	260°C	250°C	240°C
Dwell Time at Max.	10 seconds	5 seconds	*
Ramp DN (°C/sec)	N/A	N/A	N/A

Temperature Diff. = Difference between final preheat stage and soldering stage.

Convection IR Reflow			
Description	Maximum	Recommended	Minimum
Ramp Up (°C/sec)	3°C/sec	2°C/sec	*
Dwell Time > 217°C	150 seconds	90 seconds	60 seconds
Solder Temp.	260°C	245°C	*
Dwell Time at Max.	30 seconds	15 seconds	10 seconds
Ramp DN (°C/sec)	6°C/sec	3°C/sec	*

Recommended Lead Free Resistor Reflow Profile

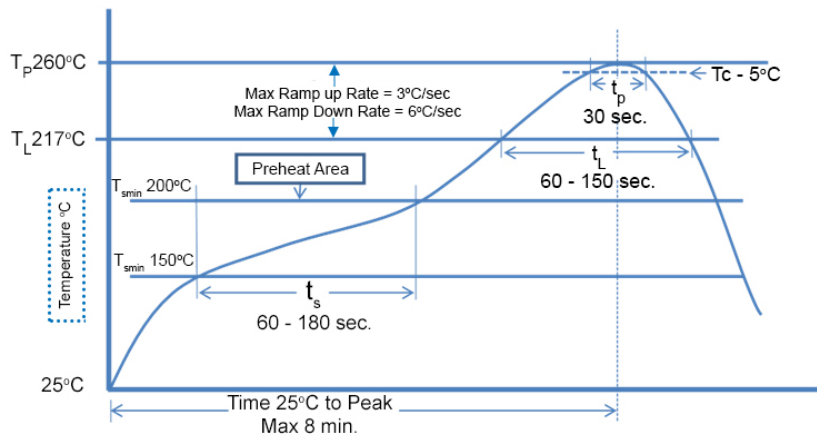

RoHS Compliance

Stackpole Electronics has joined the worldwide effort to reduce the amount of lead in electronic components and to meet the various regulatory requirements now prevalent, such as the European Union’s directive regarding “Restrictions on Hazardous Substances” (RoHS 3). As part of this ongoing program, we periodically update this document with the status regarding the availability of our compliant components. All our standard part numbers are compliant to EU Directive 2011/65/EU of the European Parliament as amended by Directive (EU) 2015/863/EU as regards the list of restricted substances.

RoHS Compliance Status

Standard Product Series	Description	Package / Termination Type	Standard Series RoHS Compliant	Lead-Free Termination Composition	Lead-Free Mfg. Effective Date (Std Product Series)	Lead-Free Effective Date Code (YY/WW)
RWT	Thermal Fusing Vertical Mount Wirewound Leaded Resistor	Radial	YES	100% Matte Sn	Always	Always

“Conflict Metals” Commitment

We at Stackpole Electronics, Inc. are joined with our industry in opposing the use of metals mined in the “conflict region” of the Eastern Democratic Republic of the Congo (DRC) in our products. Recognizing that the supply chain for metals used in the electronics industry is very complex, we work closely with our own suppliers to verify to the extent possible that the materials and products we supply do not contain metals sourced from this conflict region. As such, we are in compliance with the requirements of Dodd-Frank Act regarding Conflict Minerals.

Compliance to “REACH”

We certify that all passive components supplied by Stackpole Electronics, Inc. are SVHC (Substances of Very High Concern) free and compliant with the requirements of EU Directive 1907/2006/EC, “The Registration, Evaluation, Authorization and Restriction of Chemicals”, otherwise referred to as REACH. Contact us for complete list of REACH Substance Candidate List.

Environmental Policy

It is the policy of Stackpole Electronics, Inc. (SEI) to protect the environment in all localities in which we operate. We continually strive to improve our effect on the environment. We observe all applicable laws and regulations regarding the protection of our environment and all requests related to the environment to which we have agreed. We are committed to the prevention of all forms of pollution.

How to Order

