

Specification

Drawing No.	TKY1D-H1-15020-00 [12]-1/13
Issued Date.	January 10 , 2015

TO: KED USA

Note: In case of specification change, KYOCERA Part Number also will be changed.

Product Name	Temperature Compensated Crystal Oscillator
Product Model	KT2520K
Frequency	40.0MHz
Customer Part Number	_____
Customer Specification Number	_____
KYOCERA Part Number	KT2520K40000DAW18TAS
Remarks	RoHS Compliant, MSL=1 AEC-Q200(Grade3) Compliance

Customer Acceptance

Accept Signature	- Accept Date	
	Department	
	Person in charge	

Seller
 KYOCERA Crystal Device Corporation
 Crystal Products Sales Division
 6 Takeda Tobadono-cho, Fushimi-ku, Kyoto
 612-8501 Japan
 TEL. No. 075-604-3500
 FAX. No. 075-604-3501

Manufacturer
 Corporate Production Group
 Oscillator Division
 5850, Higashine-koh, Higashine-shi, Yamagata
 999-3701 Japan
 TEL. No. 0237-43-5611
 FAX. No. 0237-43-5615

Design Department Oscillator Engineering Department Application Engineering Section	Quality Assurance	Approved by	Checked by	Issued by
	Y.Kakuta	Y.Yokoo	N.Nakano	M.Narita

1. Purpose and scope

This document contains specification related to CRYSTAL OSCILLATOR model KT2520K40000DAW18TAS for KED USA.

2. Nominal condition

	Item	MIN.	TYP.	MAX	Unit	Conditions
1	Operating temperature range	-40	---	+85	deg.C	
2	Storage temperature range	-40	---	+85	deg.C	
3	Nominal frequency	---	40.0	---	MHz	
4	Supply voltage	1.71	1.8	1.89	V	1.8V+/-5%
5	Absolute maximum rating voltage (Supply voltage)	-0.6	---	+4.6	V	
6	Load impedance	9	10	11	kohm	
		9	10	11	pF	
7	Output signal condition	---	Clipped sine	---	---	

3. Electrical characteristics

Ta=-40 to +85deg.C, Vcc=1.8V, Load=10kohm//10pF

	Item	MIN.	TYP.	MAX	Unit	Conditions	Remarks
1	Temp characteristics	-2.0	---	+2.0	x10 ⁻⁶	On the basis of 25 deg.C frequency	
2	Voltage characteristics	-0.2	---	+0.2	x10 ⁻⁶	1.8V+/-5%	
3	Load characteristics	-0.2	---	+0.2	x10 ⁻⁶	10kohm+/-10%, 10pF+/-10%	
4	Aging characteristics	-1.0	---	+1.0	x10 ⁻⁶ /Y	1year	at 25+/-2 deg.C
5	Frequency tolerance	-2.0	---	+2.0	x10 ⁻⁶	After 2 times reflow soldering	at 25+/-2 deg.C
6	Current	---	---	2.0	mA		
7	Output voltage	0.8	---	---	Vp-p		
8	Harmonics	---	---	-8.0	dBc		
9	Start up time	---	---	1.5	ms	90% of final output amplitude	
		---	---	1.5	ms	Within ±0.5ppm	
10	Duty	45	---	55	%		
11	Phase noise	---	---	-86	dBc/Hz	@10Hz offset	at 25+/-2 deg.C
		---	---	-111	dBc/Hz	@100Hz offset	
		---	---	-133	dBc/Hz	@1kHz offset	
		---	---	-145	dBc/Hz	@10kHz offset	
		---	---	-150	dBc/Hz	@100kHz offset	
		---	---	-150	dBc/Hz	@1MHz offset	

4. Circuit

Bypass Capacitor and DC- Blocking Capacitor do not build in this TCXO.
So, Bypass Capacitor and DC- Blocking Capacitor are attached outside and please use it.
And these Capacitor should be placed as close as possible to the pin(No.4 and No.6).

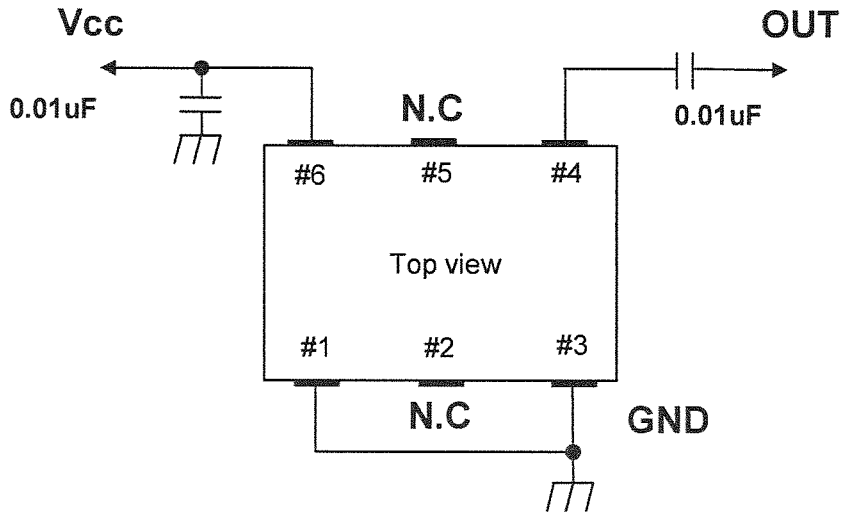

5. Test circuit

*Load $10k\Omega//10pF$ contains the internal impedance of FET probe.

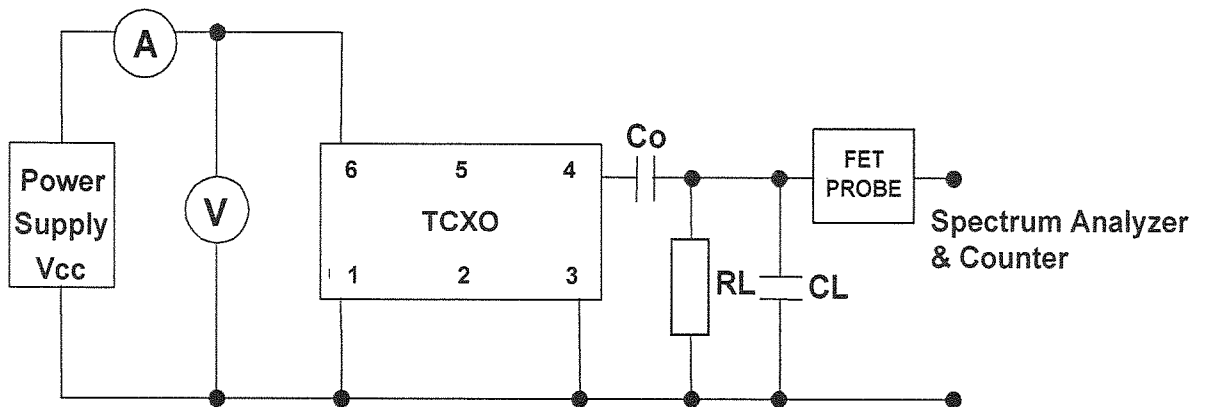

6. Environment mechanical characteristics

No	Items	Conditions	Number	Judge
1	Low Temperature Storage	-40deg.C, 1000hrs, Unpowered.	77pcs*1Lot	+/-3.0ppm max. (Before and After)
2	High Temperature Storage	+85deg.C, 1000hrs, Unpowered.	77pcs*1Lot	+/-3.0ppm max. (Before and After)
3	Temperature Cycling(Air)	-40 to +85deg.C, each30min, 1000cycles, Unpowered.	77pcs*1Lot	+/-3.0ppm max. (Before and After)
4	Vibration	10 to 50Hz/+/-0.75mm, 55 to 2000Hz/10G, 1oct./min, 24h, 3axis	30pcs*1Lot	+/-2.0ppm max. (Before and After)
5	Mechanical shock	half sign, 100G, 6msec, 3times, each 6axis (Total 18)	30pcs*1Lot	+/-2.0ppm max. (Before and After)
6	Drop test	1.2 m, Concrete floor, 20times	30pcs*1Lot	+/-2.0ppm max. (Before and After)
7	Terminal bond strength	2mm, 60sec max, 1time	30pcs*1Lot	+/-2.0ppm max. (Before and After)
8	Shear stress	20N, 60sec max.	30pcs*1Lot	+/-2.0ppm max. (Before and After)
9	Humidity tests	+85deg.C, 85%, Vcc=1.9V, 1000hrs	77pcs*1Lot	+/-3.0ppm max. (Before and After)
10	Operation life tests	+85deg.C, Vcc=1.9V, 1000hrs	77pcs*1Lot	+/-3.0ppm max. (Before and After)
11	ESD test (Human body model)	+/-2000V, 100pF, 1.5kohm, 2pulses	15pcs*1Lot	+/-2.0ppm max. (Before and After)
12	Reflow Soldering	260deg.Cpeak, 10secMAX, 3times	15pcs*1Lot	+/-2.0ppm max. (Before and After)

Normal Condition : Temperature 25 deg.C+/-2deg.C , Humidity 30 % to 70 %

7. Reflow profile

7-1. Preheat: $180 \pm 0/-10$ deg.C, 120sec (max)

7-2. Peak Temperature: $260 \pm 0/-10$ deg.C, 10sec (max)

7-3. PC-Board

Material : FR-4

Size : 140mm*110mm

Thickness : $t=0.8$ mm

7-4. Condition of Measurement Temperature: Surface of PC-BOARD

7-5. Reflow Number of Time: 2times

Reflow Soldering Condition

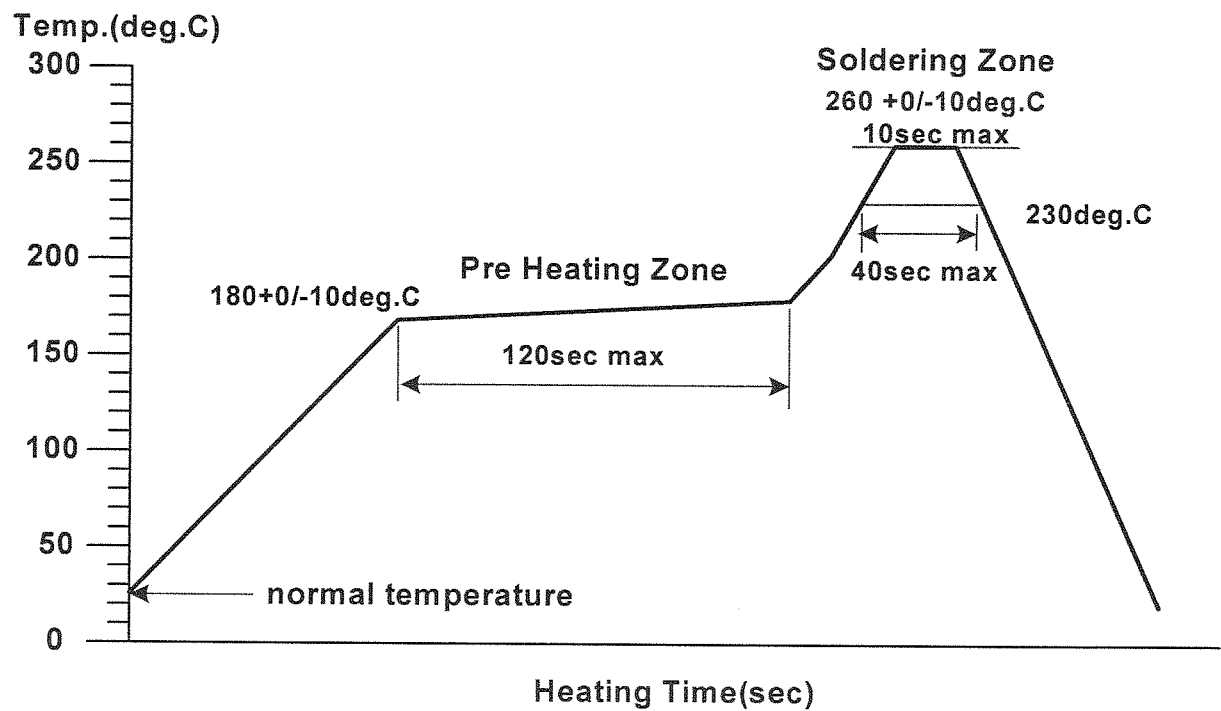

8. Marking contents

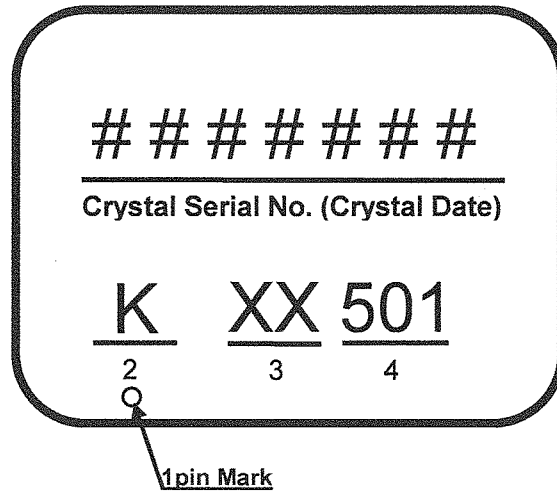

*Laser Marking

	Contents	Example
1	1Pin identifier	○
2	Control Code1	K
3	Control Code2	XX
4	Weekly Code.	501 *The 2015 1st week 502 *The 2015 2nd week

9. Dimensions

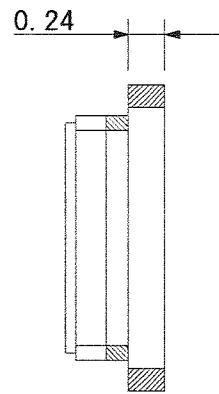
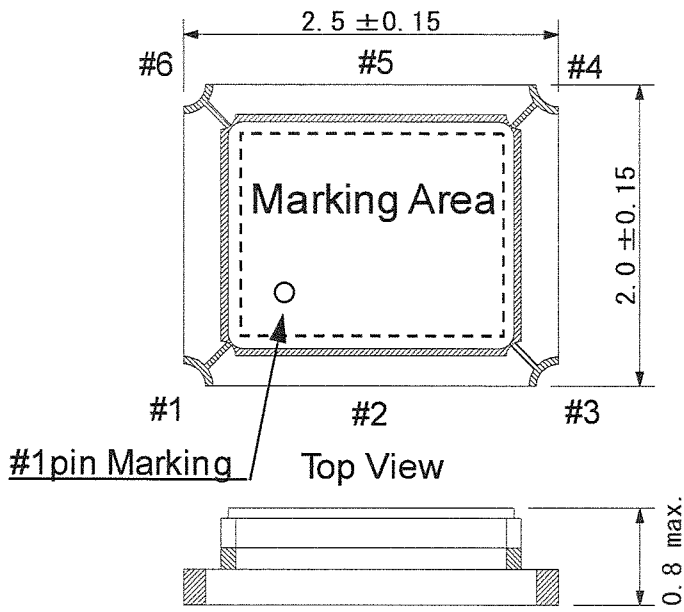

Note1
Terminal Coplanarity: 100µm max

Note2
Electrode : Cu + Ni + Au
(15µ min + 3µ min + 0.03µ min)

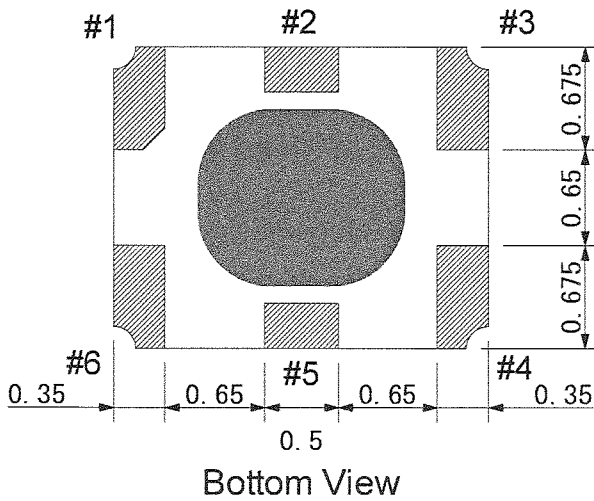

	Pin Connection
# 1 pin	GND
# 2 pin	N.C
# 3 pin	GND
# 4 pin	Output
# 5 pin	N.C
# 6 pin	Vcc

Unit: mm

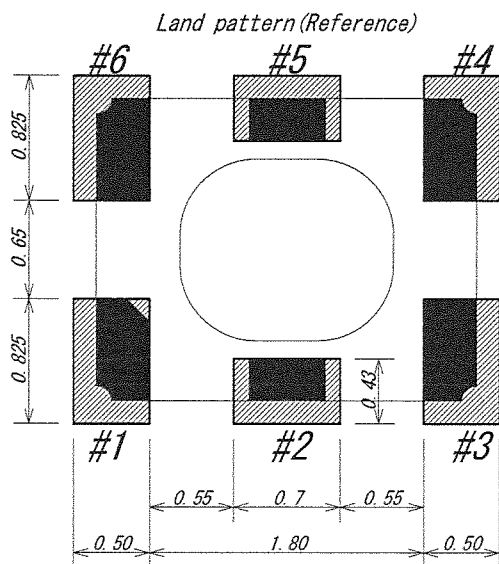

10. Tape & Reel

10-1. Tape specification

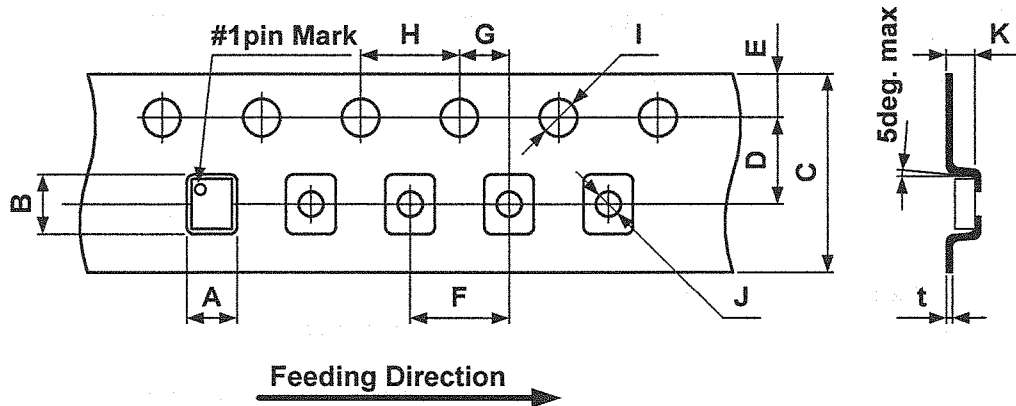

10-1-1. Carrier Tape material : PS Included Carbon

10-1-2. 1pin Mark is positioned on right side against the direction of feed.

Unit: mm

Symbol	A	B	C	D	E
Dimension	2.40 \pm 0.1	2.90 \pm 0.1	8.00 \pm 0.3/-0.2	3.50 \pm 0.05	1.75 \pm 0.1

Symbol	F	G	H	I	J
Dimension	4.00 \pm 0.1	2.00 \pm 0.05	4.00 \pm 0.1	Φ 1.5 \pm 0.1/-0	Φ 1.1 \pm 0.1

Symbol	K	t
Dimension	1.15 \pm 0.1	0.25 \pm 0.05

10-2. Reel specification

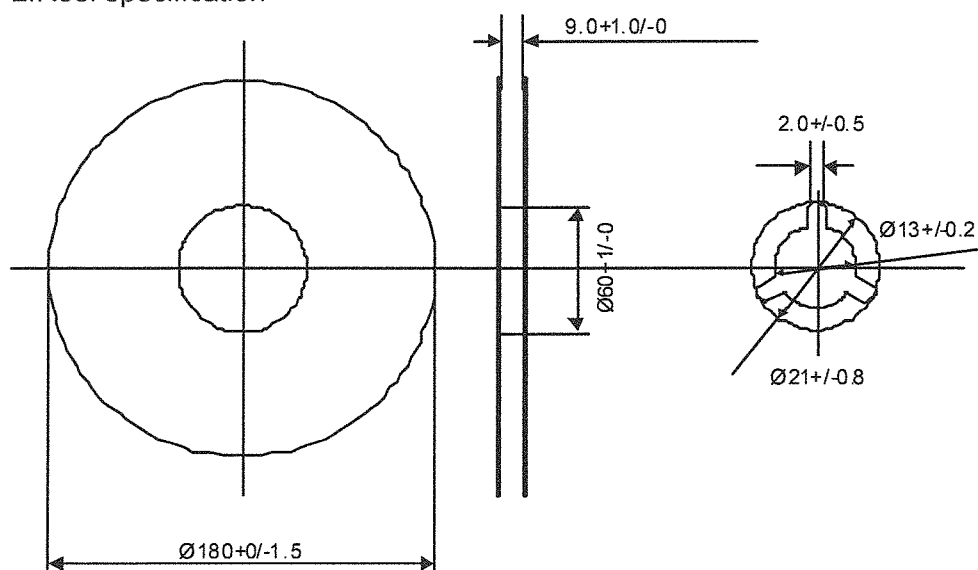

Unit: mm

10-2-1. Reel material: PS Included Carbon

10-2-2. Reel unit: 3,000pcs max. /1Reel

10-3.Packing

10-3-1.Trailer & Leader

As for the trailer and leader of taping, there are empty pockets as following drawing.
Sprocket hole is positioned on upper side against the direction of feed.
No missing components, excluding empty place.

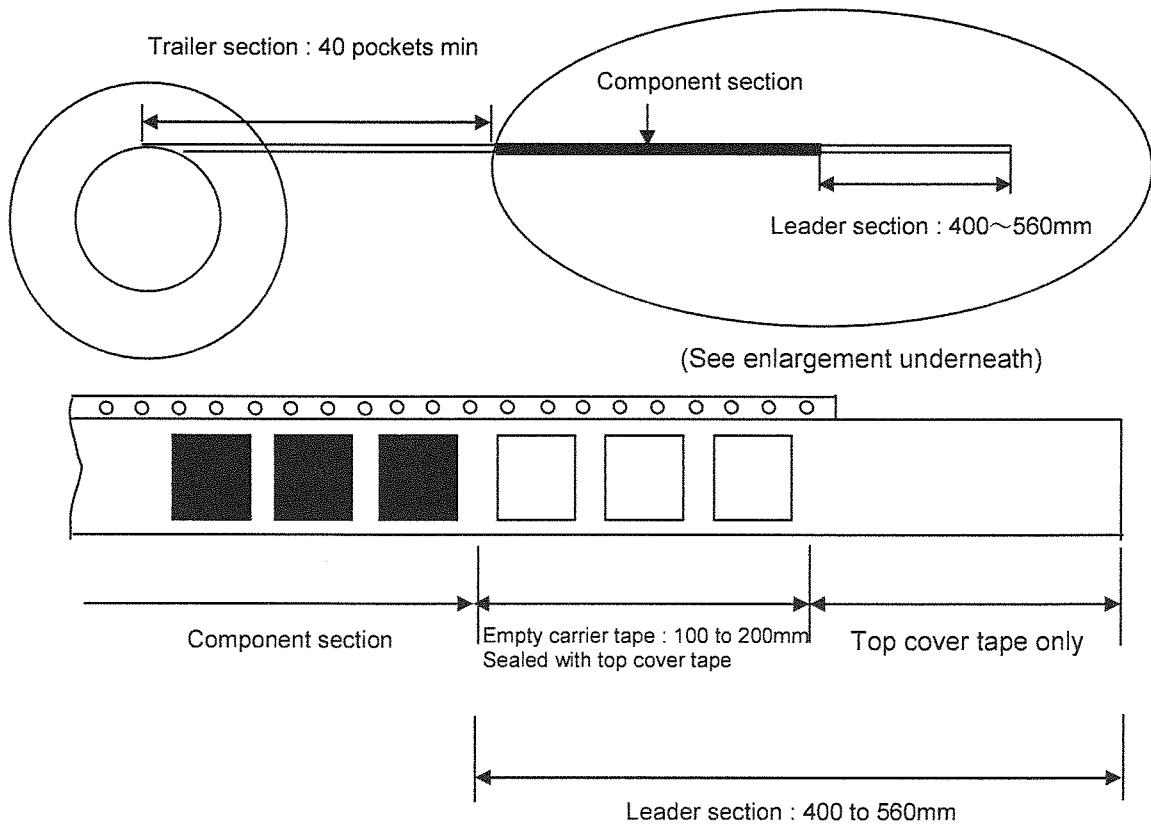

10-4. Shipping label

Following item shall be listed on reel, bag and box.
"Customer's name", "Parts No", "Lot No", "Quantity", "Order No", "Date of manufacture"
The form of the label conforms to JEITA standard pattern C-3.

11. Top Cover breaking and peeling force

11-1. Reel Angle: 165 to 180deg

11-2. Tape Break Force: 10N min

11-3. Top Cover Tape Strength: 10N min

11-4. Top Cover Tape Peel Force: 0.1 to 1.0N

11-5. Top Cover Tape Peel Speed: 300+/-10mm / minute

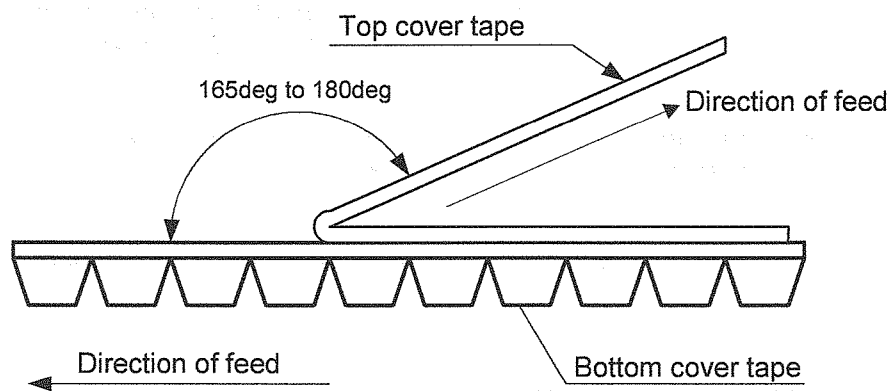

12. Notice

- 12-1. Please use soldering iron and the spot heater within the range of a solder heat test condition.
- 12-2. Units should be stored in a dry environment keeping away from the sun.
- 12-3. Don't leave units in High-temperature and High-humidity environment due to terminal solderability.
(Please keep 0 to 40deg.C and 30 to 70%RH for recommendable storage condition)
- 12-4. The term of a guarantee of taping packing is 6 months. (0 deg.C to 40 deg.C,RH30% to 70%)
- 12-5. Disapprove of washing.
- 12-6. Unless we receive request for modification within 1 month from the issue date of this KCD specification sheet, we will supply products according to this specification.
Also, if you'd like to modify specification of order, which has been placed with delivery within 1 month from the issue data of this specification sheet, we would like to discuss with you separately.
- 12-7. If you intend to use products listed on this specification for applications that may result in loss of life or assets (controls relating to safety, medical equipment, aeronautical equipment, space equipment, etc.), please do not fail to advise us of your intention beforehand.
- 12-8. In no event shall the company be liable for any product failure resulting from an inappropriate handling or operation of the product beyond the scope of its guarantee.
- 12-9. Information contained in this specification must not be quoted, reproduced or used for other purposes including processing either in part or in full without obtaining prior approval from the company.
- 12-10. Please keep it at the place that was the ESD protective.
Human model 1.5kohm 100pF : +/-2000V
Machine model 0kohm 200pF : +/-200V

13. Production place

13-1 Manufacturer

KYOCERA Crystal Device Corporation.

13-2 The site of the Factory

5850 Higasine-Koh, Higasine-shi, Yamagata, 999-3701, Japan

14. Parts Numbering Guide

KT2520K 40000 D A W 18 T AS
 A B C D E F G H

- A. Series (2.5x2.0 SMD KT2520K)
- B. Frequency (40.0MHz)
- C. Frequency temperature accuracy (D: +/-2.0ppm)
- D. Minimum temperature range (A: -40degC)
- E. Maximum temperature range (W: +85deg.C)
- F. Supply voltage (18: 1.8V)
- G. Control voltage stability (T: TCXO)
- H. Customer special model Suffix