



Heat Exchangers

TUBE TO FIN, LIQUID-TO-AIR HEAT EXCHANGERS

ATS tube-to-fin, liquid-to-air heat exchangers are made with the industry's highest density fins to maximize heat transfer from liquid to air, allowing the liquid to be cooled to lower temperatures than other heat exchangers on the market. The heat exchanger fins and tubes are made of copper and stainless steel to be suitable for a variety of fluids, including water, dielectric fluids and custom designed heat transfer fluids.

Each of the seven heat exchanger sizes is available with or without a fan. ATS heat exchangers can be used in laser cooling, medical equipment and imaging devices, compressor cooling, semiconductor processing, HVAC, food and beverage processing, and other liquid cooling applications.



GENERAL FEATURES

- » Length: 5.8 to 21.9"
- » Width: 5.8 to 14"
- » Height: 1.8 to 2.6"
- » Tube diameter: 0.375 and 0.5"
- » Copper tubes
- » Copper fins
- » High-efficiency and high density fin design
- » Silver-solder brazed joints
- » Internally cleaned and corrosion protected
- » Externally coated for corrosion protection
- » Can be customized for different fans
- » 100% pressure tested

APPLICATIONS

- » Automotive
- » Aerospace
- » Medical
- » Laser cooling
- » Electronics Cooling
- » Compressor Cooling
- » Semiconductor Processing
- » HVAC

For further information, please contact
Advanced Thermal Solutions, Inc. at
1-781-769-2800 or **www.qats.com**

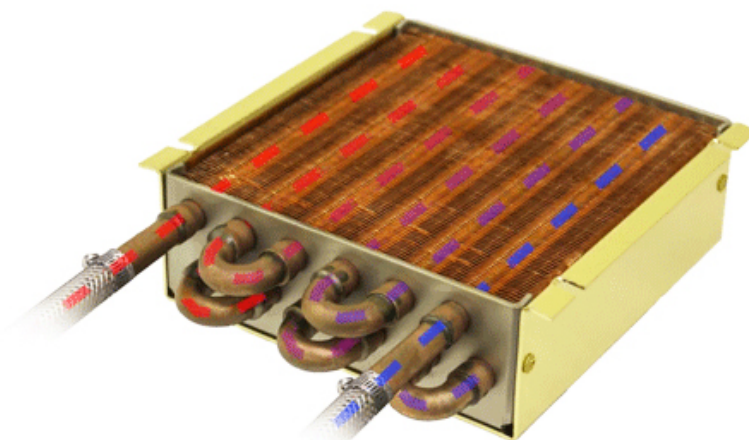



ATS-HE20 SERIES

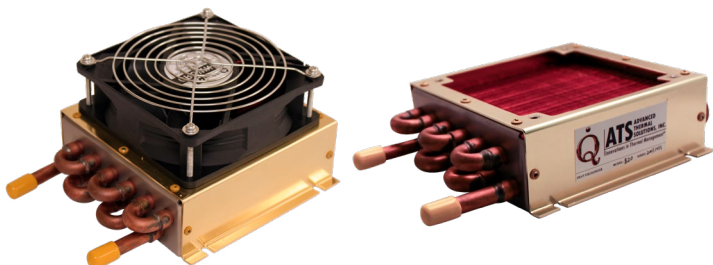

MPN	FAN TYPE	# OF FANS	FAN SIZE (inches)
ATS-HE20-C1-R0	NO FAN	0	N/A
ATS-HE20-C2-R0	12V	1	4.25 Square
ATS-HE20-C3-R0	12V PWM	1	4.25 Square
ATS-HE20-C4-R0	24V	1	4.25 Square
ATS-HE20-C5-R0	24V PWM	1	4.25 Square
ATS-HE20-C6-R0	48V	1	4.25 Square
ATS-HE20-C7-R0	48V PWM	1	4.25 Square

- » Heat transfer capacity up to 22W per $\Delta T = 1^{\circ}\text{C}$
- » 5.8 x 5.8 x 1.8" core size
- » $\Delta T = \text{inlet liquid temperature} - \text{inlet air temperature}$
- » Weight: 1077g (2.4 lbs), Weight w/fan: 1411g (3.1 lbs)
- » Maximum pressure: 100 psi

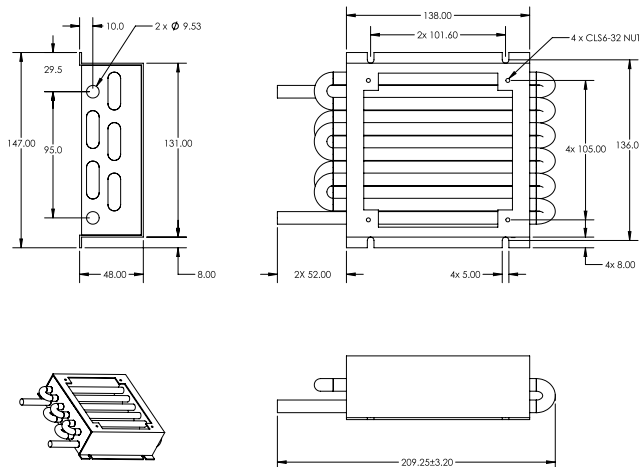

ATS-HE21 SERIES

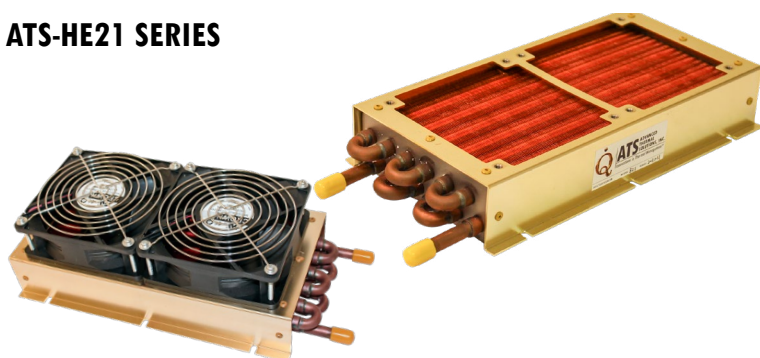

MPN	FAN TYPE	# OF FANS	FAN SIZE (inches)
ATS-HE21-C1-R0	NO FAN	0	N/A
ATS-HE21-C2-R0	12V	2	4.25 Square
ATS-HE21-C3-R0	12V PWM	2	4.25 Square
ATS-HE21-C4-R0	24V	2	4.25 Square
ATS-HE21-C5-R0	24V PWM	2	4.25 Square
ATS-HE21-C6-R0	48V	2	4.25 Square
ATS-HE21-C7-R0	48V PWM	2	4.25 Square

- » Heat transfer capacity up to 46W per $\Delta T = 1^{\circ}\text{C}$
- » 10.5 x 5.8 x 1.8" core size
- » $\Delta T = \text{inlet liquid temperature} - \text{inlet air temperature}$
- » Weight: 1759g (3.9 lbs); Weight w/fan: 2405g (5.3 lbs)
- » Maximum pressure: 100 psi

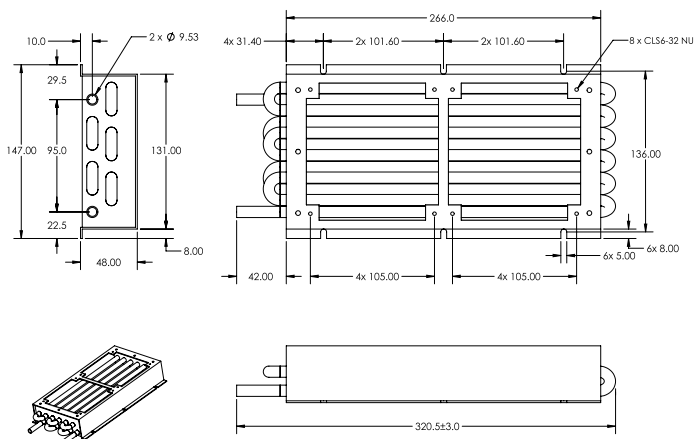



ATS-HE22 SERIES



MPN	FAN TYPE	# OF FANS	FAN SIZE (inches)
ATS-HE22-C1-R0	NO FAN	0	N/A
ATS-HE22-C2-R0	12V	1	6.75 Round
ATS-HE22-C3-R0	12V PWM	1	6.75 Round
ATS-HE22-C4-R0	24V	1	6.75 Round
ATS-HE22-C5-R0	24V PWM	1	6.75 Round
ATS-HE22-C6-R0	48V	1	6.75 Round
ATS-HE22-C7-R0	48V PWM	1	6.75 Round

- » Heat transfer capacity up to 64W per $\Delta T = 1^{\circ}\text{C}$
- » 9.5 x 9.0 x 2.5" core size
- » $\Delta T =$ inlet liquid temperature - inlet air temperature
- » Weight: 2211g (4.9 lbs); Weight w/fan: 2854g (6.23 lbs)
- » Maximum pressure: 100 psi

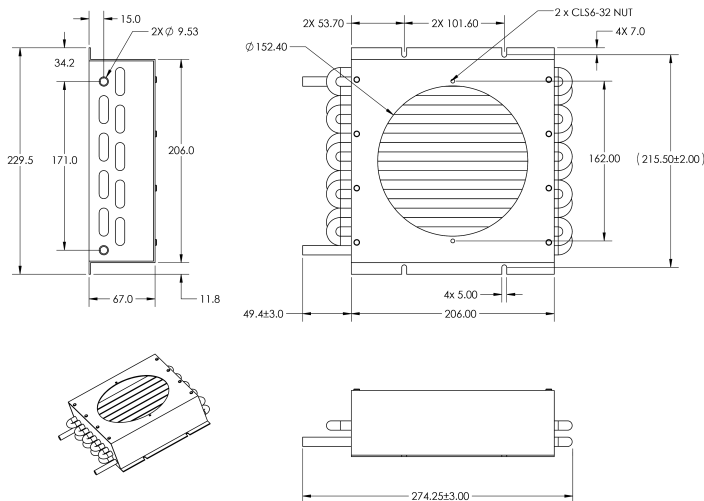

ATS-HE23 SERIES

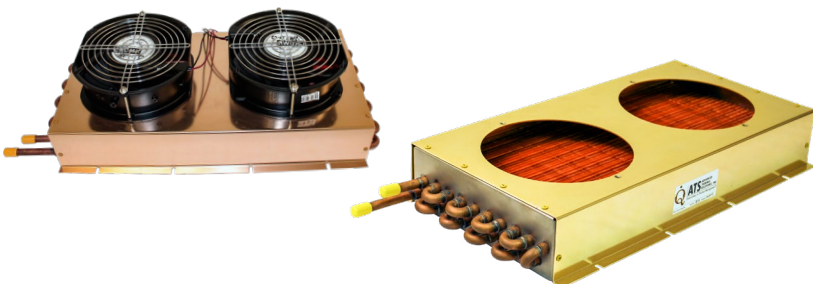

MPN	FAN TYPE	# OF FANS	FAN SIZE (inches)
ATS-HE23-C1-R0	NO FAN	0	N/A
ATS-HE23-C2-R0	12V	2	6.75 Round
ATS-HE23-C3-R0	12V PWM	2	6.75 Round
ATS-HE23-C4-R0	24V	2	6.75 Round
ATS-HE23-C5-R0	24V PWM	2	6.75 Round
ATS-HE23-C6-R0	48V	2	6.75 Round
ATS-HE23-C7-R0	48V PWM	2	6.75 Round

- » Heat transfer capacity up to 117W per $\Delta T = 1^{\circ}\text{C}$
- » 17.5 x 9.0 x 2.5" core size
- » $\Delta T =$ inlet liquid temperature - inlet air temperature
- » Weight: 7000g (15.4 lbs); Weight w/fan: 7600g (16.8 lbs)
- » Maximum pressure: 100 psi

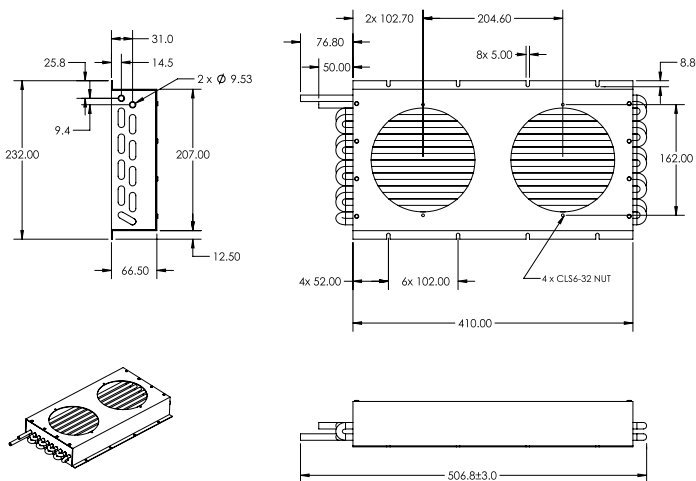



ATS-HE24 SERIES

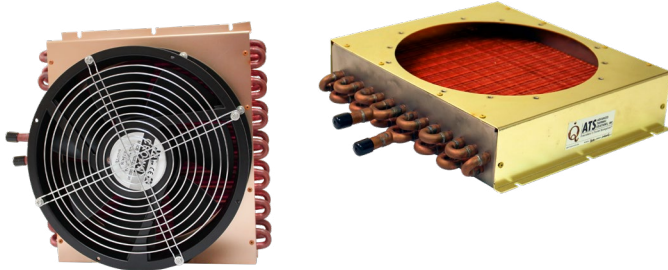

MPN	FAN TYPE	# OF FANS	FAN SIZE (inches)
ATS-HE24-C1-R0	NO FAN	0	N/A
ATS-HE24-C2-R0	12V	1	10.0 Round
ATS-HE24-C3-R0	12V PWM	1	10.0 Round
ATS-HE24-C4-R0	24V	1	10.0 Round
ATS-HE24-C5-R0	24V PWM	1	10.0 Round
ATS-HE24-C6-R0	48V	1	10.0 Round
ATS-HE24-C7-R0	48V PWM	1	10.0 Round

- » Heat transfer capacity up to 97W per $\Delta T = 1^{\circ}\text{C}$
- » 11.5 (L) x 12.0 (W) x 2.12 (H)" core size
- » ΔT = inlet liquid temperature - inlet air temperature
- » Weight: 4018g (8.9 lbs); Weight w/fan: 5791g (12.8 lbs)
- » Maximum pressure: 100 psi

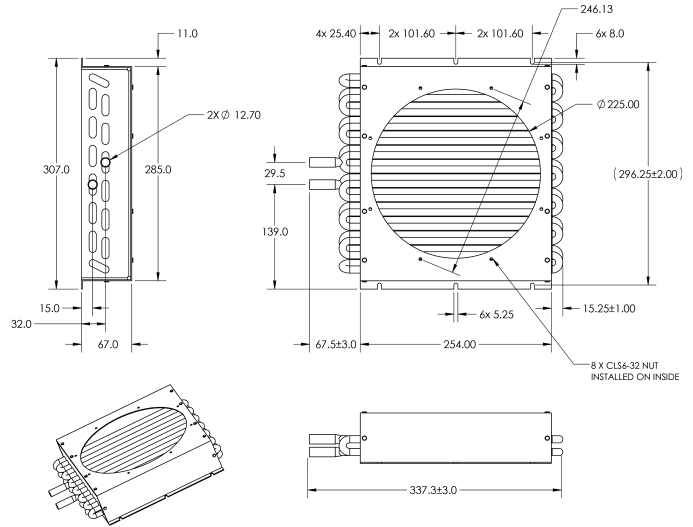

ATS-HE25 SERIES

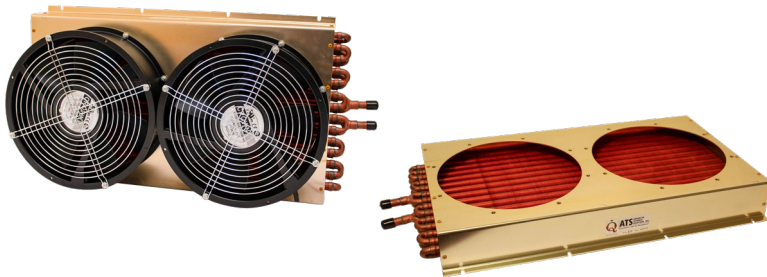

MPN	FAN TYPE	# OF FANS	FAN SIZE (inches)
ATS-HE25-C1-R0	NO FAN	0	N/A
ATS-HE25-C2-R0	12V	2	10.0 Round
ATS-HE25-C3-R0	12V PWM	2	10.0 Round
ATS-HE25-C4-R0	24V	2	10.0 Round
ATS-HE25-C5-R0	24V PWM	2	10.0 Round
ATS-HE25-C6-R0	48V	2	10.0 Round
ATS-HE25-C7-R0	48V PWM	2	10.0 Round

- » Heat transfer capacity up to 177W per $\Delta T = 1^{\circ}\text{C}$
- » 21.58 (L) x 12.0 (W) x 2.12 (H)" core size
- » ΔT = inlet liquid temperature - inlet air temperature
- » Weight: 7422g (16.4 lbs); Weight w/fan: 11012g (24.23 lbs)
- » Maximum pressure: 100 psi

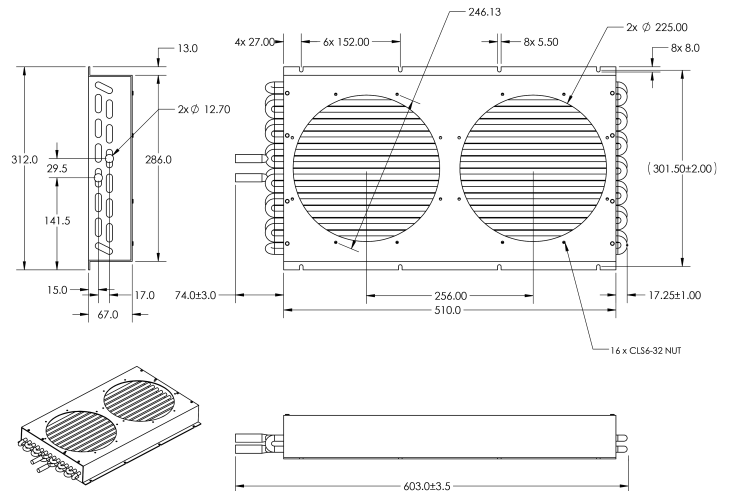



ATS-HE26 SERIES

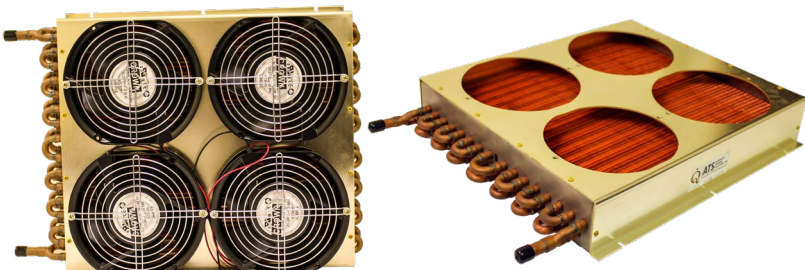

- » Heat transfer capacity up to 250W per $\Delta T = 1^{\circ}\text{C}$
- » 17.52 (L) x 14.0 (W) x 2.63 (H)" core size
- » ΔT = inlet liquid temperature - inlet air temperature
- » Weight: 4018g (8.9 lbs); Weight w/fan: 5791g (12.8 lbs)
- » Maximum pressure: 100 psi

MPN	FAN TYPE	# OF FANS	FAN SIZE (inches)
ATS-HE26-C1-R0	NO FAN	0	N/A
ATS-HE26-C2-R0	12V	4	6.75 Round
ATS-HE26-C3-R0	12V PWM	4	6.75 Round
ATS-HE26-C4-R0	24V	4	6.75 Round
ATS-HE26-C5-R0	24V PWM	4	6.75 Round
ATS-HE26-C6-R0	48V	4	6.75 Round
ATS-HE26-C7-R0	48V PWM	4	6.75 Round

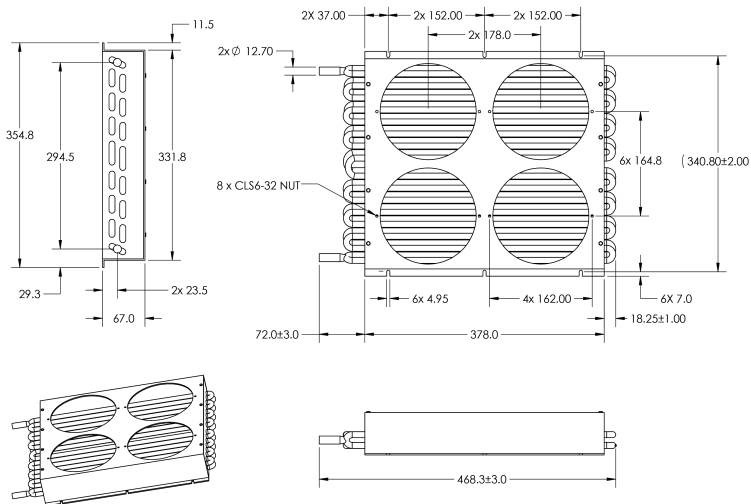

ADDITIONAL COMPONENTS DEPLOYED IN LIQUID COOLING LOOPS



Flow Meter



Leak Detector

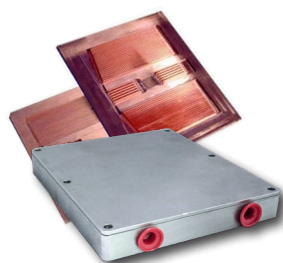

Cold Plates



Chillers



Heat Exchangers

ATS has the products needed to design a complete liquid cooling loop: **Cold Plates** to transfer and remove the heat from the source, **Heat Exchangers** to transfer heat from the liquid to the air with or without a fan, and **Chillers** to circulate and condition the fluid in the system. In addition, ATS offers **Flow Meters** to instantaneously measure the volumetric flow rate of the fluid in the system and **Leak Detectors** to notify users of any leaks in the system.



Heat Exchangers (cont'd)

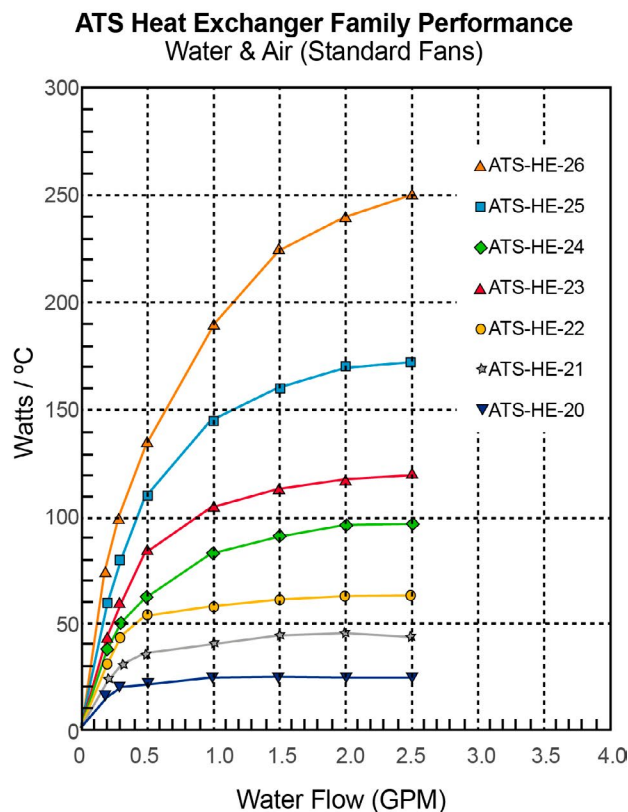
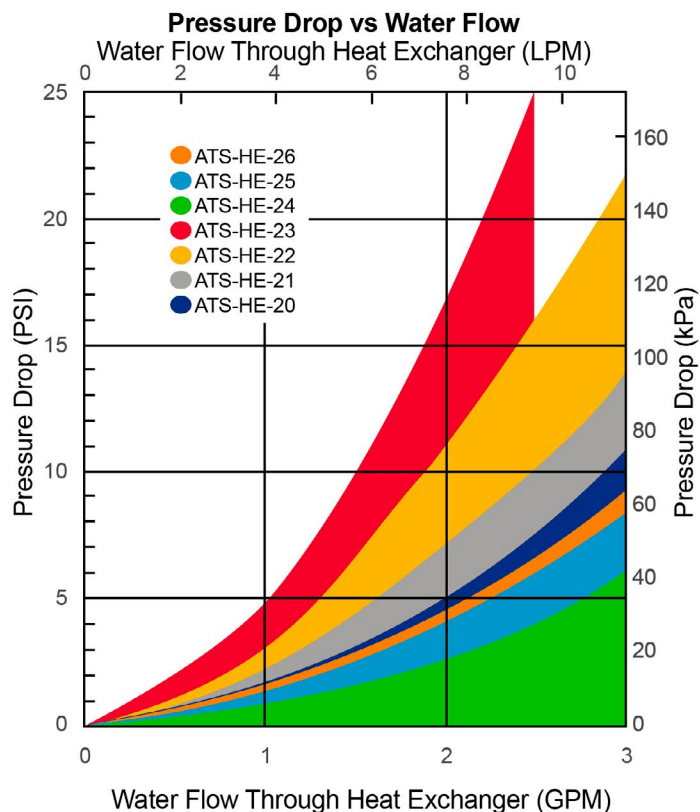
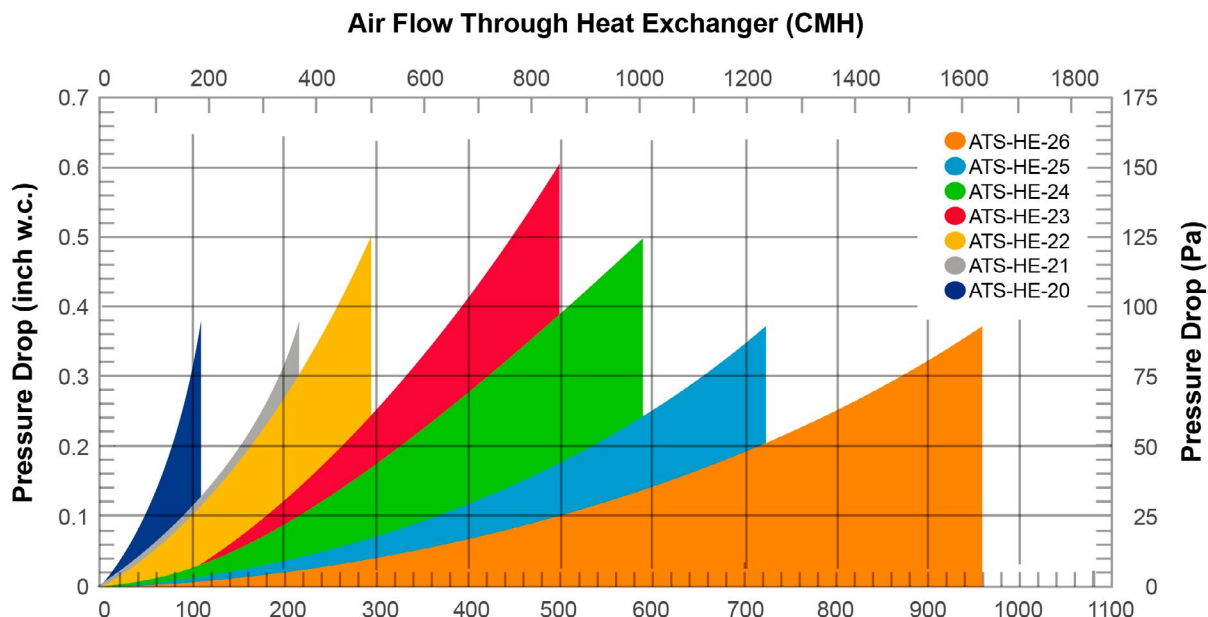

Note: Performance curves are per $\Delta T = 1^\circ C$ | $\Delta T = \text{inlet liquid temperature} - \text{inlet air temperature}$