

Customer Information Sheet

DRAWING No.: M80-851XXXX

IF IN DOUBT - ASK

©

NOT TO SCALE

THIRD ANGLE PROJECTION

ALL DIMENSIONS IN mm

SPECIFICATIONS:

MATERIAL:

MOULDING = GLASS-FILLED PPS UL94V-0, BLACK

CONTACTS = PHOSPHOR BRONZE

LATCHES = BERYLLIUM COPPER

FINISH:

CONTACTS (ALL OVER NICKEL):

22 = 0.75µm GOLD ON CONTACT AREA,
3.0µm 90/10 TIN/LEAD ON TAILS

42 = 0.75µm GOLD ON CONTACT AREA,
3.0µm 100% TIN ON TAILS

45 = 0.75µm GOLD

LATCH = 1.25µm NICKEL

ELECTRICAL:

CURRENT RATING (25°C) = 3.0A MAX.

CURRENT RATING (85°C) = 2.2A MAX.

WORKING VOLTAGE = 800V AC/DC

VOLTAGE PROOF = 1200V AC/DC

CONTACT RESISTANCE (INITIAL) = 20mΩ MAX.

CONTACT RESISTANCE (AFTER CONDITIONING) = 25mΩ MAX.

INSULATION RESISTANCE (INITIAL) = 1000MΩ MIN.

INSULATION RESISTANCE (AFTER CONDITIONING) = 100MΩ MIN.

MECHANICAL:

DURABILITY = 500 OPERATIONS

ENVIRONMENTAL:

TEMPERATURE RANGE = -55°C TO +125°C

PACKING:

TUBE

FOR COMPLETE SPECIFICATION, SEE COMPONENT SPECIFICATION C005XX (LATEST ISSUE)

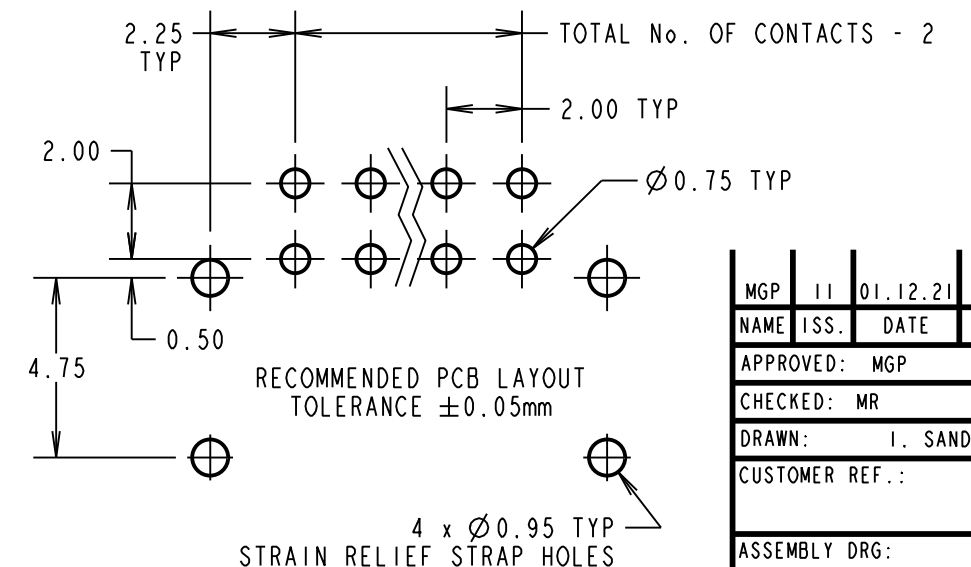
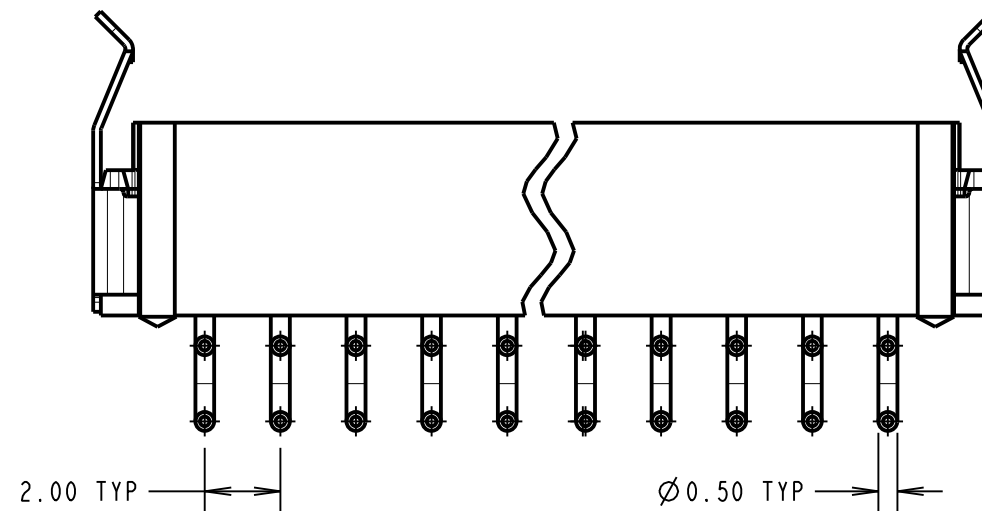
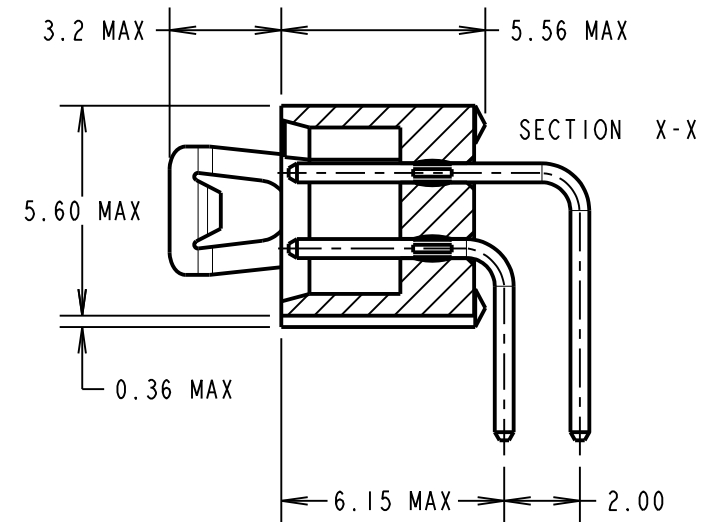
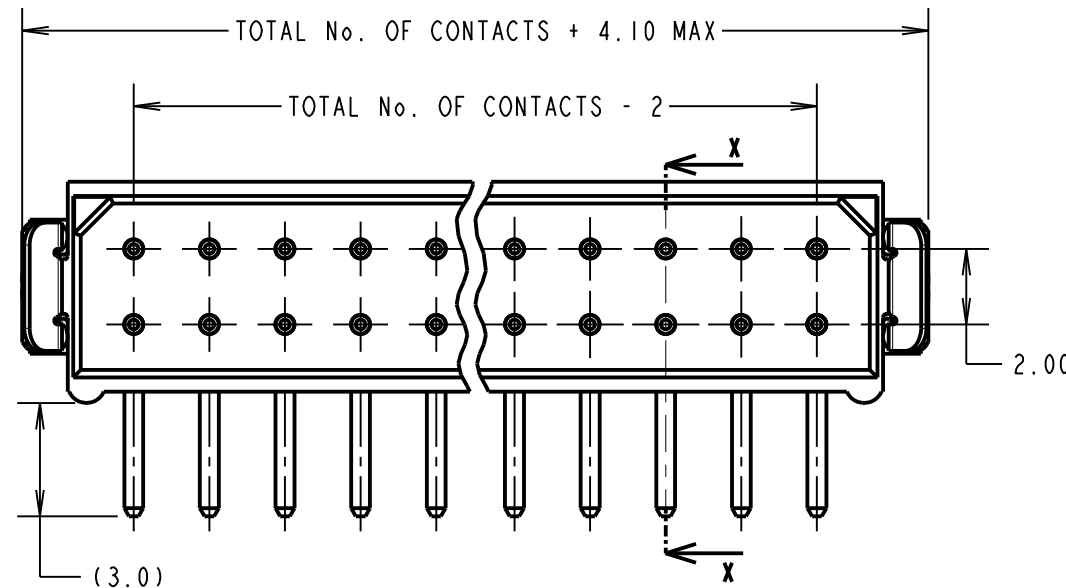

ORDER CODE:

M80-851XXXX

TOTAL No. OF CONTACTS:

04, 06, 08, 10, 12, 14, 16,
18, 20, 26, 34, 44

FINISH:

22 = SELECTIVE GOLD + TIN/LEAD
42 = SELECTIVE GOLD + 100% TIN
45 = GOLD

NOTES:

- 2-OFF STRAIN RELIEF STRAP M80-0030006 ARE INCLUDED WITH EACH CONNECTOR.

HARWIN

www.harwin.com
technical@harwin.com

THIS DRAWING AND ANY INFORMATION OR DESCRIPTIVE MATTER SET OUT HEREON ARE CONFIDENTIAL AND COPYRIGHT PROPERTY OF THE HARWIN GROUP AND MUST NOT BE DISCLOSED, LOANED, COPIED OR USED FOR MANUFACTURING, TENDERING OR FOR ANY OTHER PURPOSE WITHOUT THEIR WRITTEN PERMISSION.

TOLERANCES

X. = ±1mm
X.X = ±0.50mm
X.XX = ±0.20mm
X.XXX = ±0.01mm

ANGLES = ±5°

UNLESS STATED

MATERIAL:

SEE ABOVE

FINISH: SEE ABOVE

S/AREA:

mm²

TITLE:

DATAMATE DIL
HORIZONTAL 90° TAIL PLUG
ASSEMBLY - LATCHED

DRAWING NUMBER:

M80-851XXXX

MGP	11	01.12.21	31135
NAME	ISS.	DATE	CN/CO

APPROVED: MGP

CHECKED: MR

DRAWN: I. SANDY

CUSTOMER REF.:

ASSEMBLY DRG:

SHT
2 OF 2