

LOC		DIST		P		ZONE		LTR		REVISIONS	
CM	53									DESCRIPTION	DATE
										F REVISED PER OG1B-0081-99	28-MAY-99
											APPD KW JS

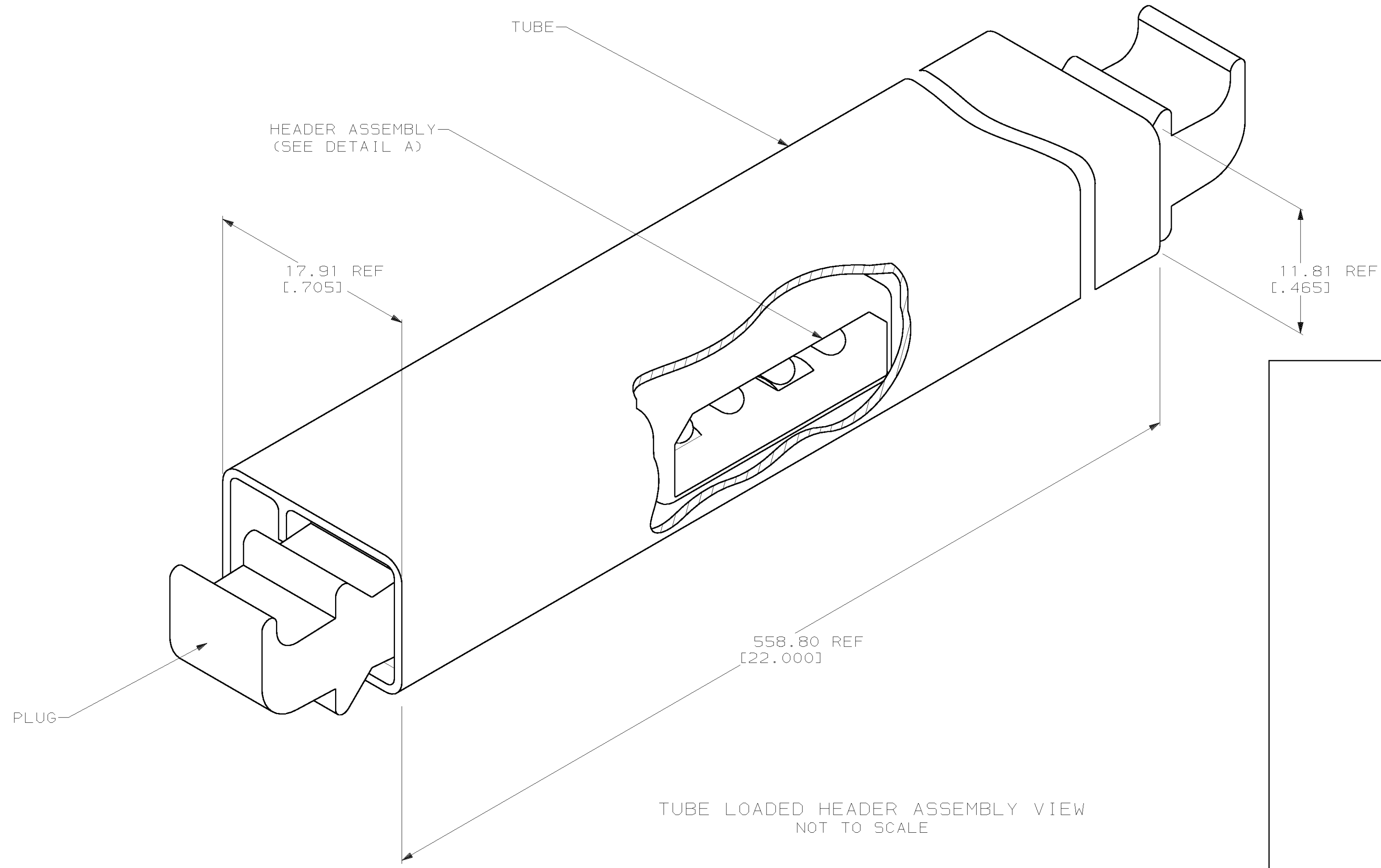

- PARTS COMPLY WITH AMP SOLDERABILITY SPEC. 109-11-3.
- MATERIAL: HOUSING - NYLON, UL94V-2, NATURAL
 PIN - COPPER ALLOY, BRIGHT TIN-LEAD PLATED, 0.0020 [.00080] MIN. THK.

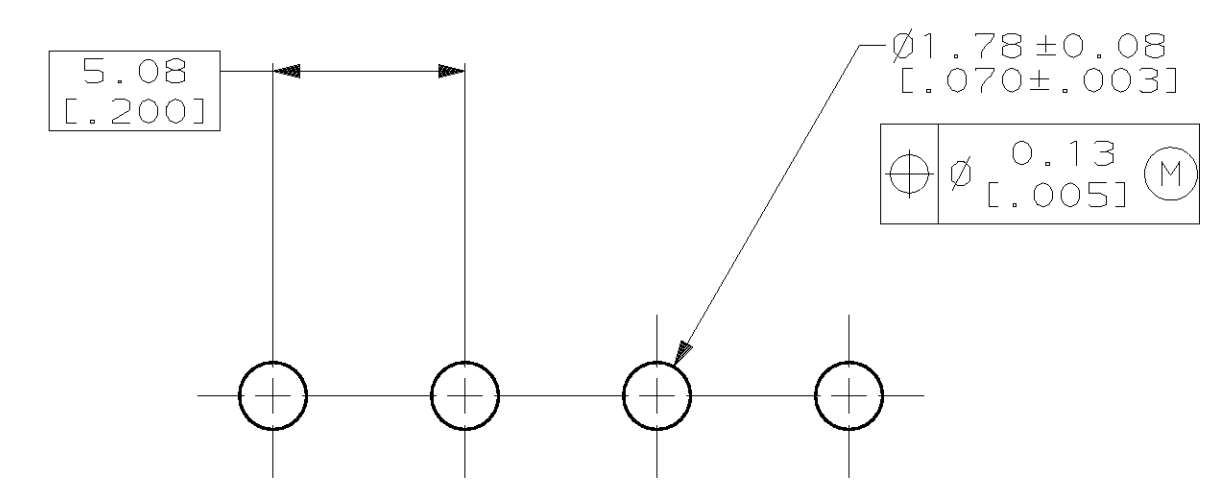
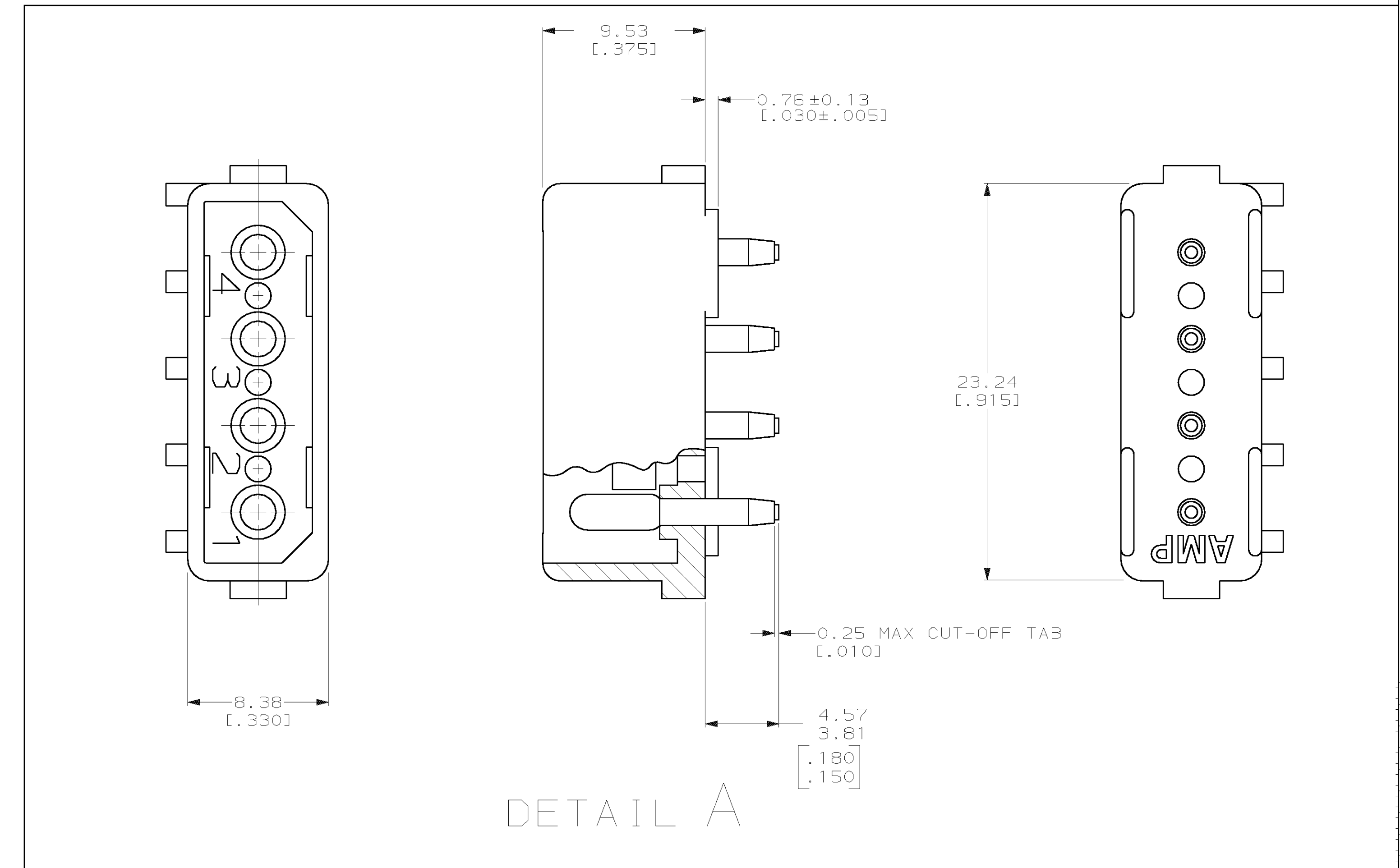

RECOMMENDED MOUNTING HOLE PATTERN FOR 1.57 [.062] THICK P.C. BOARD

-	-	4	770328-1
20	2	4	1-770328-1
HEADER ASSY	PLUG	NO. OF POSITIONS	PART NUMBER
QTY PER TUBE		HEADER ASSEMBLY	

DO NOT SCALE PRINT. UNLESS SPECIFIED DIMENSIONS IN mm [INCHES]		DR K. WHITAKER 7-7-89		PART NO	
TOLERANCES ON:		CHK R. SWING 7-10-89		AMP INCORPORATED Harrisburg, Pa. 17105	
2 PLC DEC ± -		APPD G. BROWN 7-11-89		NAME	
3 PLC DEC ± 0.38 [.015]		MATERIAL		HEADER ASSY, 4 CKT, TUBE LOADED, COMMERCIAL MATE-N-LOK™	
ANGLES ± -		FINISH		SIZE	
MATERIAL		APPLICATION SPEC		CAGE CODE	
3		-		D 00779	
3		-		DRAWING NO	
-		-		770328	
WEIGHT		SCALE		SHEET	
-		5:1		1 OF 1	

