

| REVISIONS |                          |      |          |
|-----------|--------------------------|------|----------|
| LTR       | DESCRIPTION              | DATE | APPROVED |
| N/C       | RELEASED PER ECN T-20873 |      |          |

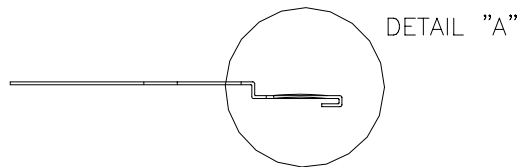
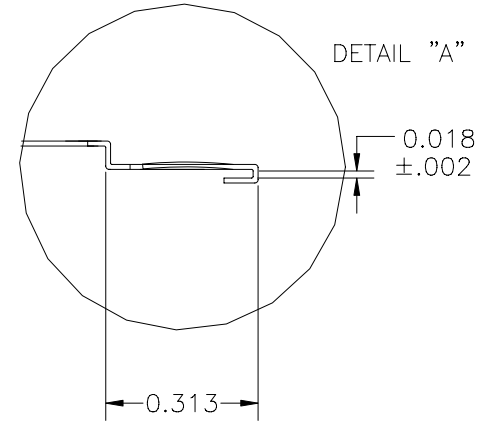
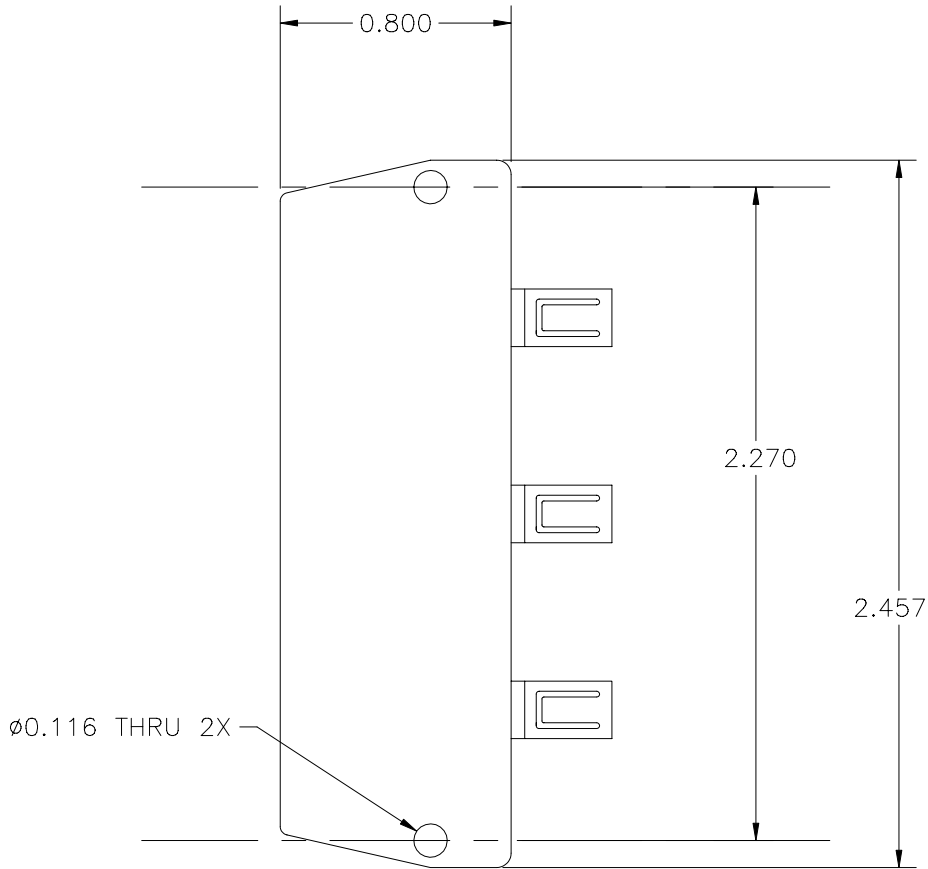

© Raychem Corporation 1988

# SPECIFICATION CONTROL DRAWING

**If this document is printed it becomes uncontrolled.  
Check with the web for latest revision.**

1. NICKEL PLATE PER MIL-C-26074, CLASS 2, .000150/.000250 THICKNESS.

NOTES:

|   |                        |            |             |  |              |                 |          |     |
|---|------------------------|------------|-------------|--|--------------|-----------------|----------|-----|
| UNLESS OTHERWISE SPECIFIED<br>DIMENSIONS ARE IN INCHES.<br>METRIC DIMENSIONS ARE<br>IN BRACKETS.<br><br>DECIMALS<br>.XXX ± .005 [ mm<br>.XX ± .01 [ mm<br>ANGLES<br>.X ± 1°<br>MATERIAL Be Cu 172A<br>0.010 THICKNESS | DRAWN                  | TIMM       | 04/16/96    | <b>Raychem</b><br><small>RAYCHEM CORPORATION<br/>         300 CONSTITUTION DRIVE<br/>         MENLO PARK, CALIFORNIA 94025</small> |              |                 |          |     |
|   | CHECKED                |            |             |  |              | TITLE           |          |     |
|   | APPROVED               |            |             | BUSBAR, 2"   |              |                 |          |     |
|   | PCN                    | 156773-000 |             | FOR PLUG SHELL<br>GROUNDING BLOCK  |              |                 |          |     |
|   | CAD NAME               |            | \010058.DWG |  | SIZE         | CODE IDENT. NO. | DWG. NO. | REV |
|   | THIRD ANGLE PROJECTION |            |             |  | C            | 06090           | CHA-0292 | N/C |
| DO NOT SCALE THIS DRAWING   |                        |            |             |  | SHEET 1 OF 1 |                 |          |     |

DWG NO. CHA-0292 SHEET 1