

THIS DRAWING IS UNPUBLISHED.

RELEASED FOR PUBLICATION

ALL RIGHTS RESERVED.

© COPYRIGHT - By -

LOC	DIST	REVISIONS					
AF	50	P	LTR	DESCRIPTION	DATE	DWN	APVD
			D2	REVISED PER ECR-19-018151	12NOV2020	AA	EW

- △1 CONTINUOUS STRIP ON REELS
- △2 REELED ON PLASTIC REELS
- △3 FINISH LEAD-FREE, MATTE TIN OVER NICKEL

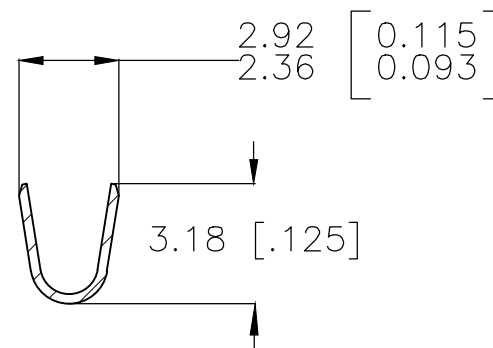
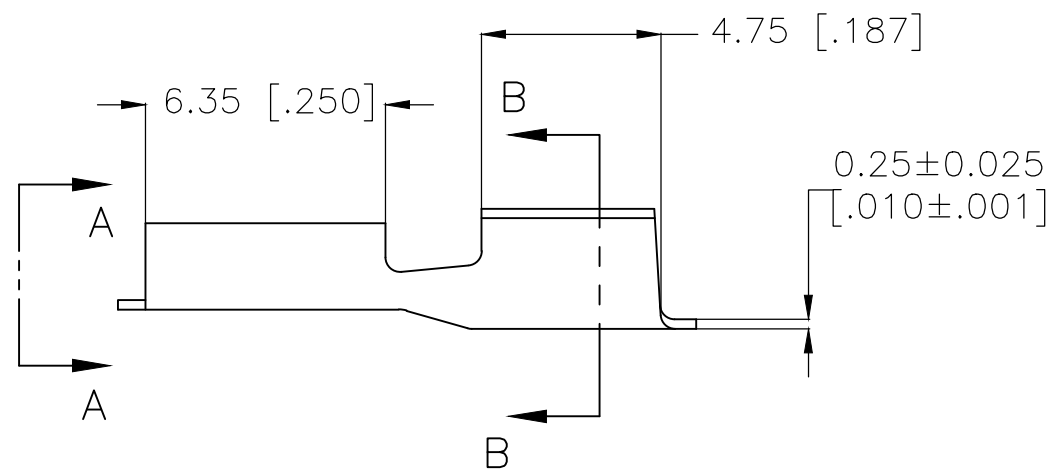
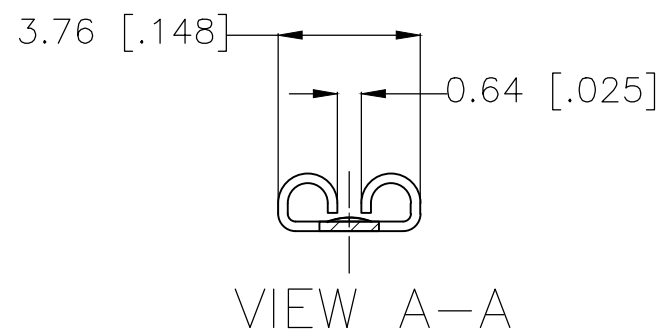
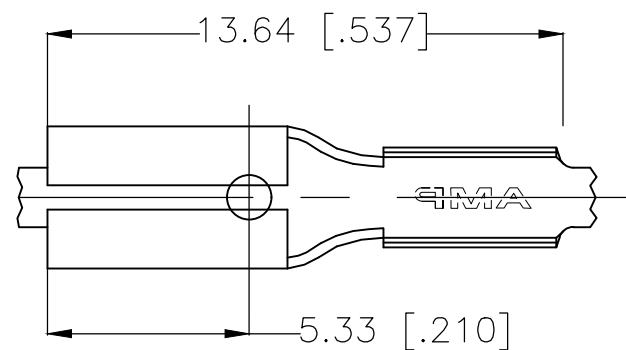

SECTION B-B

OBSOLETE	[20-16] AWG	0.41±0.025 [.016±.001]	△3	61457-3
			PRE-TIN	△2 61457-2
			PRE-TIN	61457-1
WIRE SIZE	MATING TAB THK	FINISH	PART NO.	

THIS DRAWING IS A CONTROLLED DOCUMENT.		DWN	JR RUTH	30NOV00	<b>STE</b> TE Connectivity		
DIMENSIONS: mm [INCHES]		CHK	MS FEHER	30NOV00			
TOLERANCES UNLESS OTHERWISE SPECIFIED:		APVD	P DESANTIS	30NOV00	NAME		
0 PLC ± -		PRODUCT SPEC		RECEPTACLE, FASTON, 2.79 [.110] SERIES			
1 PLC ± -		APPLICATION SPEC		SIZE	CAGE CODE	DRAWING NO	RESTRICTED TO
2 PLC ± 0.38 [.015]		MATERIAL		A300779		C-61457	-
3 PLC ± -		FINISH		CUSTOMER DRAWING		SCALE	SHEET
4 PLC ± -		SEE TABLE		SCALE 5:1		SHEET 1 OF 1	REV D2
ANGLES ± -		MATERIAL		SCALE 5:1		SHEET 1 OF 1	REV D2
MATERIAL		FINISH		SCALE 5:1		SHEET 1 OF 1	REV D2
BRASS		SEE TABLE		SCALE 5:1		SHEET 1 OF 1	REV D2