

LOC	DIST	REV	DATE	BY	CHK	APPV
AA	22	K1	18MAY2011	RK	HMR	
		L	27APR2015	LL	SH	

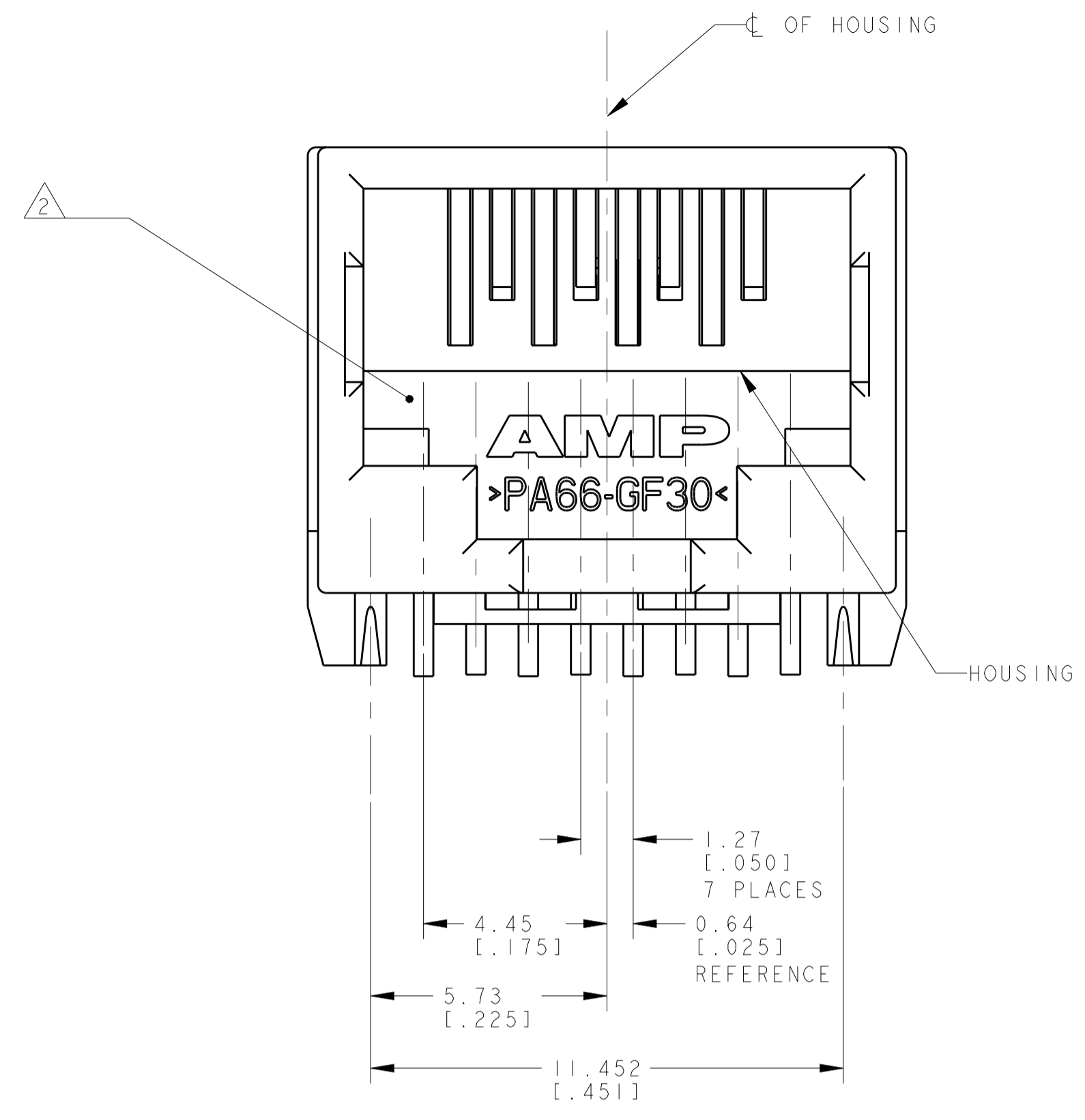

- △ MATERIAL: HOUSING - HIGH TEMPERATURE NYLON, BLACK, UL 94V-0, IR REFLOW SOLDERING PROCESS COMPATIBLE
TERMINALS - 0.25[.010] THICK PHOSPHOR BRONZE PLATED WITH 3.81µm[.000150] MINIMUM THICK BRIGHT TIN-LEAD IN SOLDER AREA, 1.27µm[.000050] MINIMUM GOLD IN LOCALIZED PLATE AREA. ENTIRE TERMINAL PLATED WITH 1.27µm[.000050] MINIMUM THICK NICKEL.
- △ JACK CAVITY CONFORMS TO FCC RULES AND REGULATIONS PART 68, SUBPART F.
- △ THIS DIMENSION REPRESENTS THE TOTAL HEIGHT OF THE CONNECTOR FROM THE TOP OF THE PC BOARD.
- 4. PACKAGED 66 ASSEMBLIES PER PVC TRAY, 396 PER BOX.
- △ MANUFACTURING DATE CODE:
ORIENTED AND LOCATED APPROXIMATELY AS SHOWN. LASER PRINTING.
TEXT HEIGHT APPROXIMATELY 2MM.
FIRST 2 DIGITS = LAST 2 DIGITS OF YEAR
NEXT 2 DIGITS = MANUFACTURING WORK WEEK
LAST DIGIT = DAY OF WEEK WITH SUNDAY = 1
- △ MATERIAL: HOUSING - HIGH TEMPERATURE NYLON, BLACK, UL 94V-0, IR REFLOW SOLDERING PROCESS COMPATIBLE
TERMINALS - 0.25[.010] THICK PHOSPHOR BRONZE PLATED WITH 3.81µm[.000150] MINIMUM THICK MATTE TIN IN SOLDER AREA, 1.27µm[.000050] MINIMUM GOLD IN LOCALIZED PLATE AREA. ENTIRE TERMINAL PLATED WITH 1.27µm[.000050] MINIMUM THICK NICKEL.

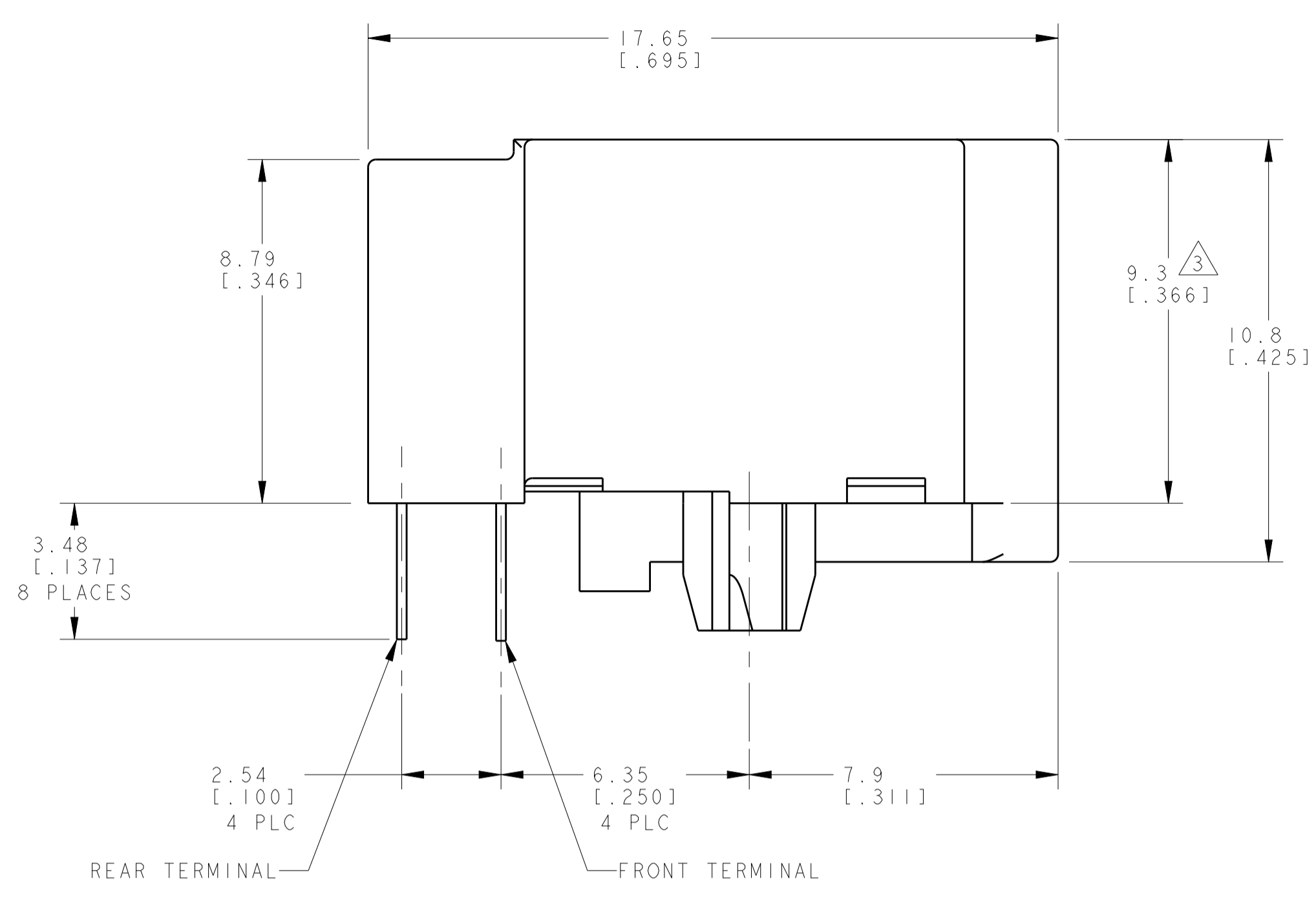
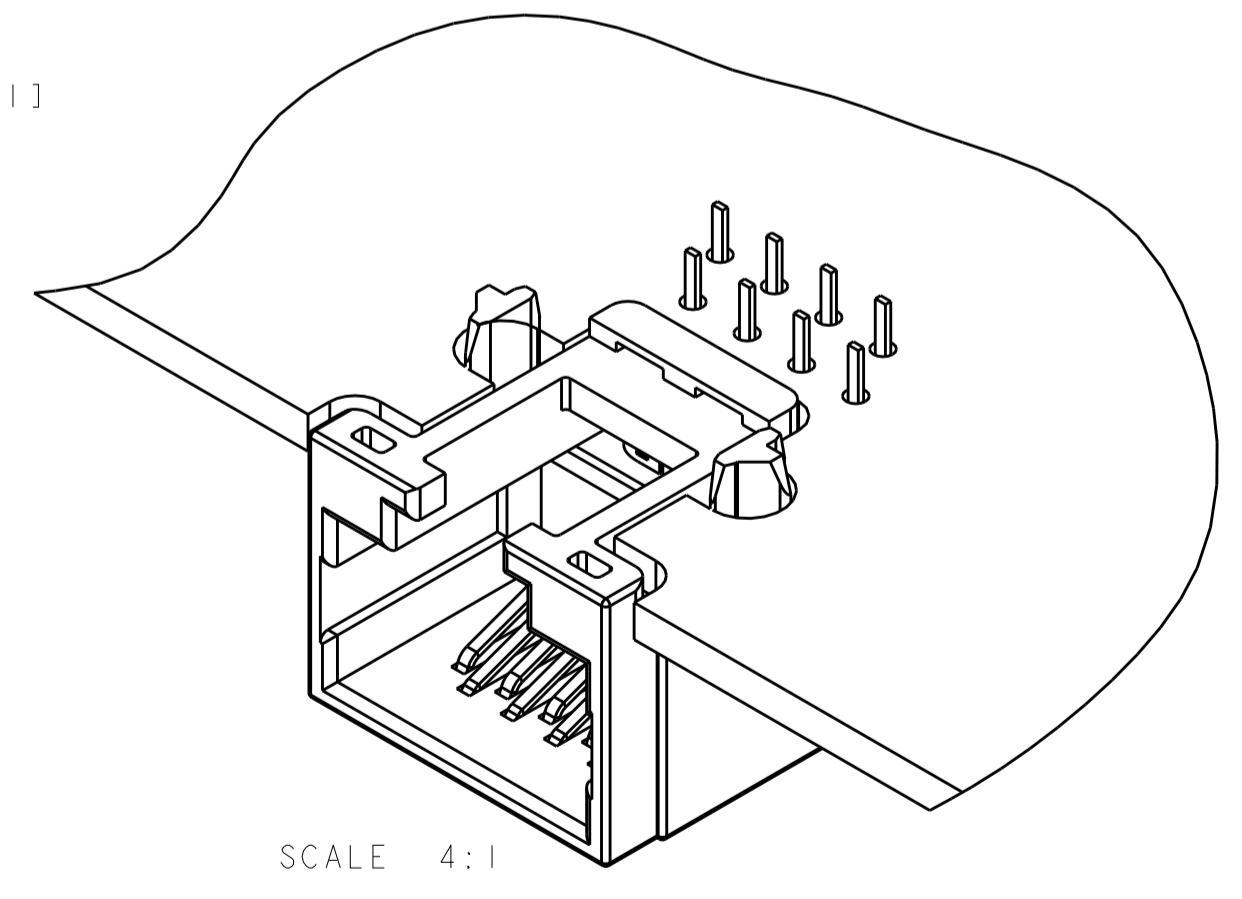
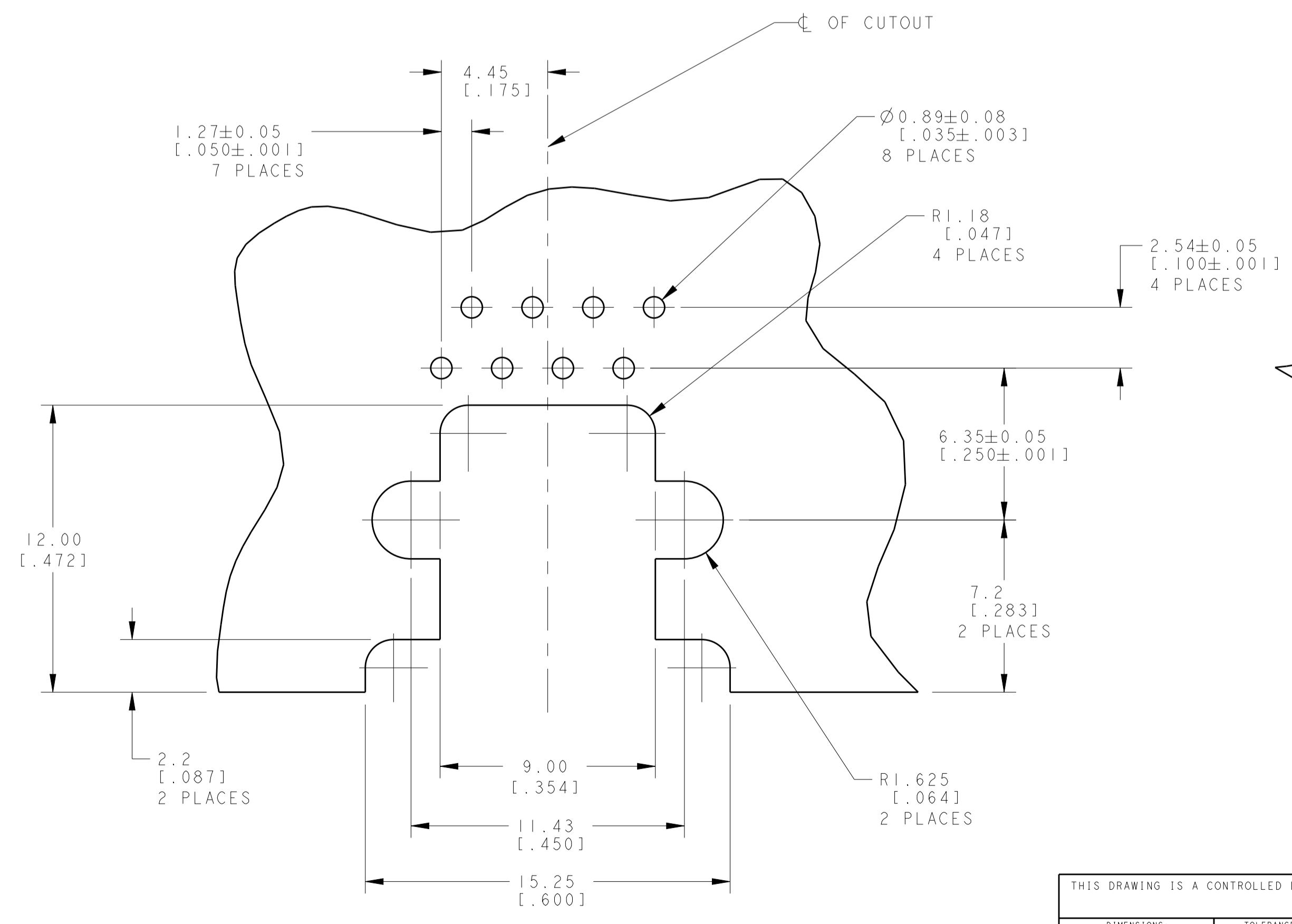
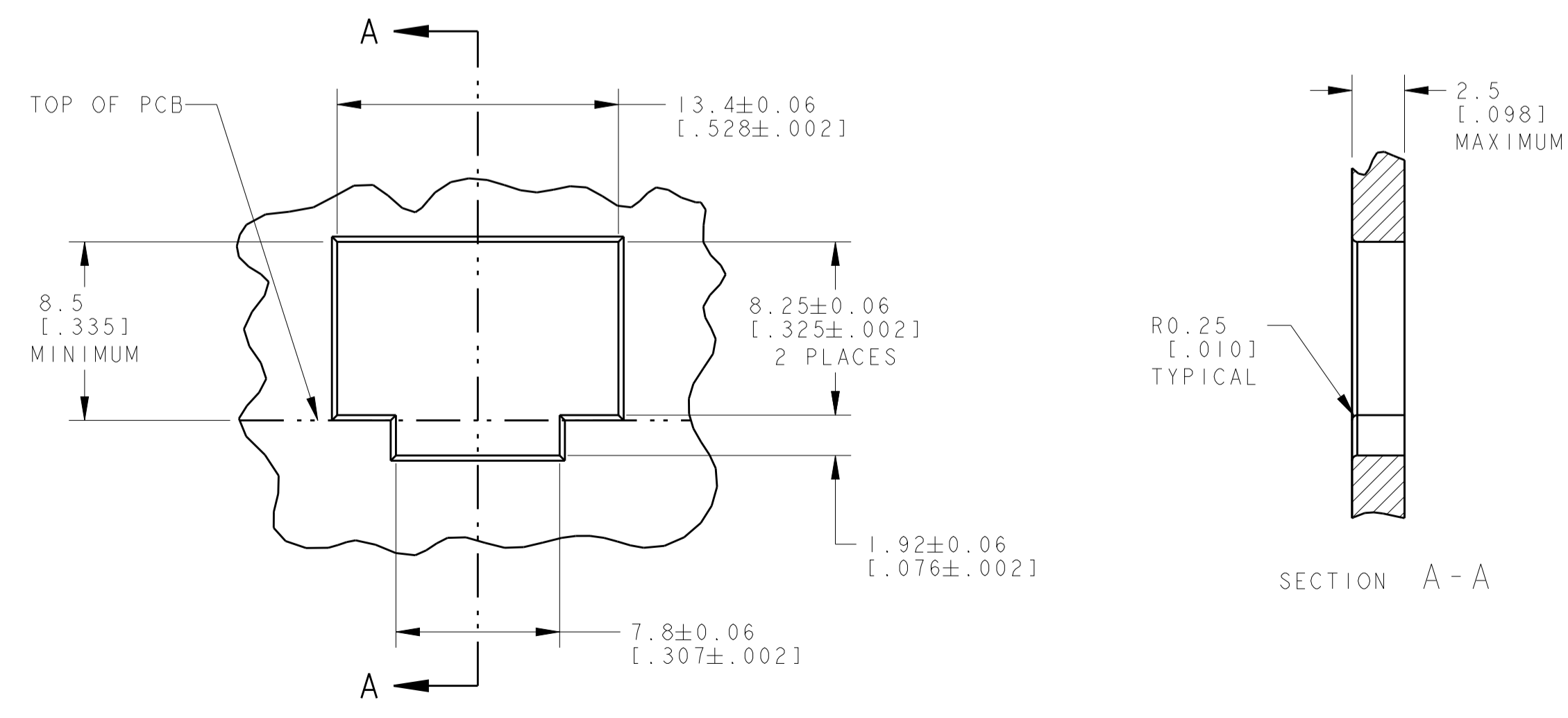
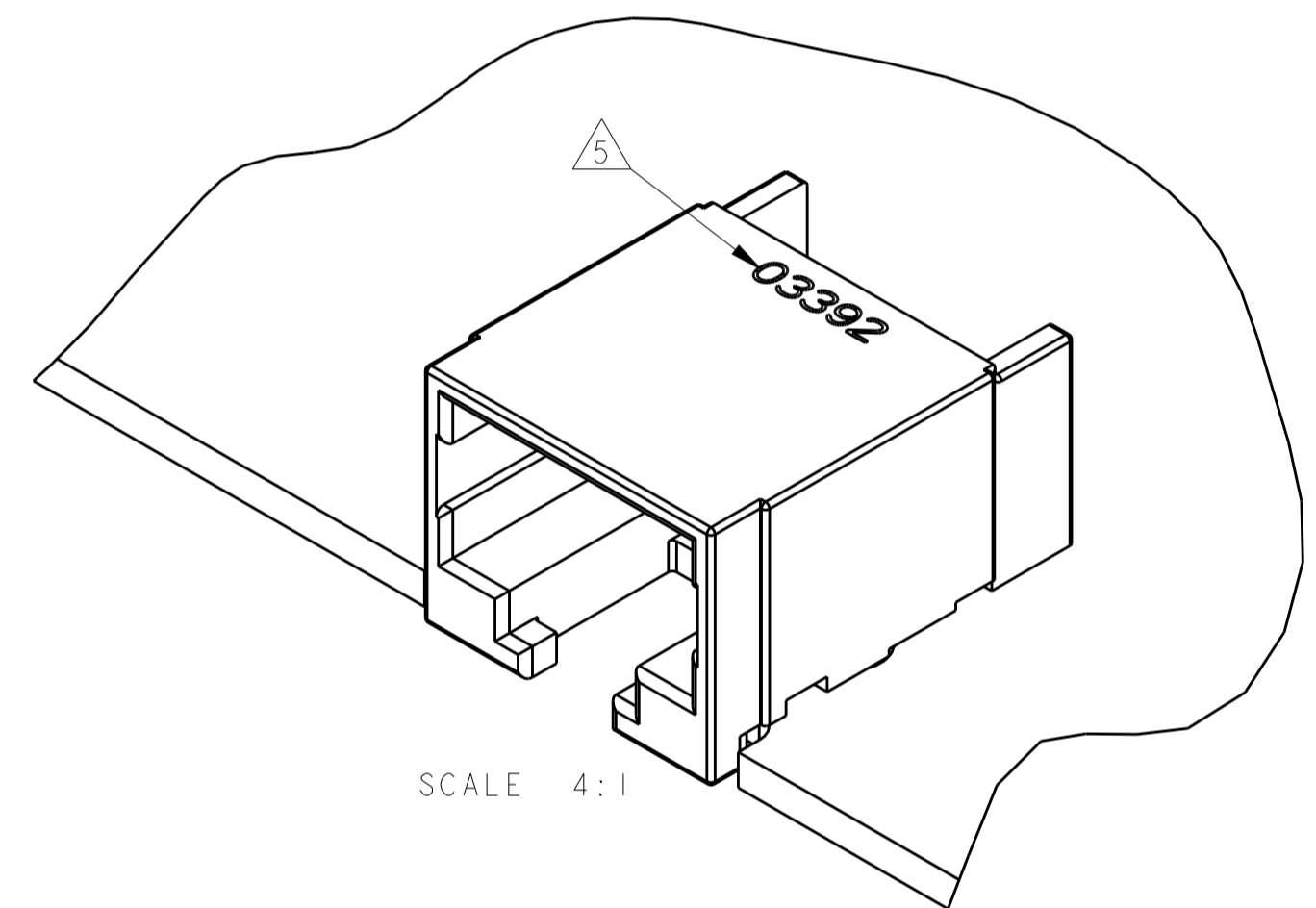
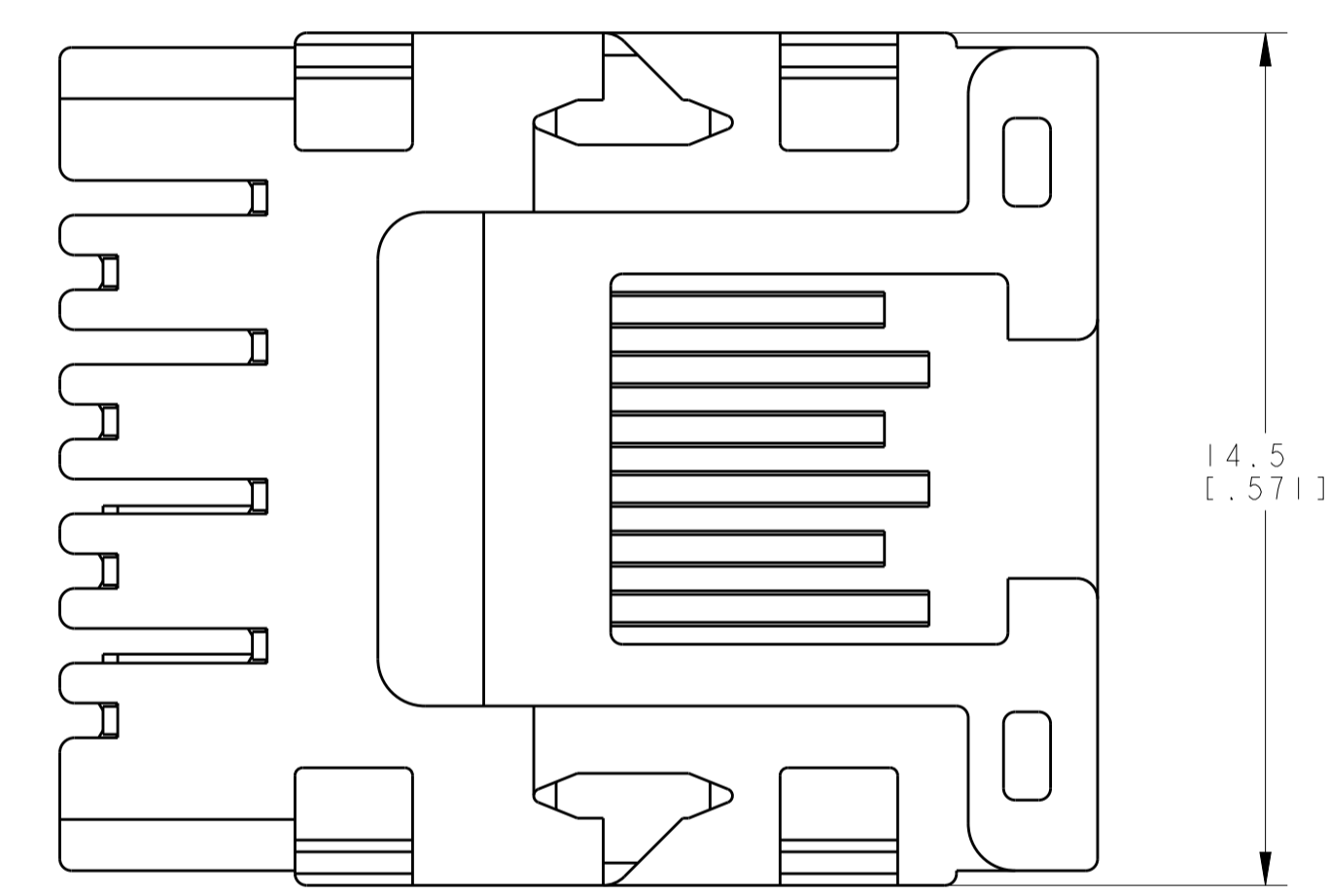

△	1116504-2
△	1116504-1
MATERIAL/ FINISH	PART NUMBER

THIS DRAWING IS A CONTROLLED DOCUMENT.		OWN	T. SPRINKLE	28JAN99
DIMENSIONS: mm [INCHES]		CHK	D. KEMPKA	28JAN99
TOLERANCES UNLESS OTHERWISE SPECIFIED:		APPV	D. KEMPKA	28JAN99
0 PLC	±	PRODUCT SPEC		
1 PLC	±	NAME	MODULAR JACK ASSEMBLY, 8 POSITION, 10mm	
2 PLC	±0.131(.005)	APPLICATION SPEC		
3 PLC	±	SIZE	CAGE CODE	DRAWING NO
4 PLC	±	108-1163		114-2048
ANGLES	±	WEIGHT	3.49 grams	
MATERIAL	SEE P/N TABLE	FINISH	SEE P/N TABLE	RESTRICTED TO
CUSTOMER DRAWING		A100779		1116504
SCALE		8:1	SHEET	1 OF 1