

THIS DRAWING IS UNPUBLISHED.

RELEASED FOR PUBLICATION

20

© COPYRIGHT 20 BY -

ALL RIGHTS RESERVED.

REVISIONS

P	LTR	DESCRIPTION	DATE	DWN	APVD
A		INITIAL RELEASE	24FEB2016	wi	wi
B		ECR-16-006868	11MAY2016	KH	CW

Matrize in Kombination mit Ergocrimp Basishandzange PN 539635-1 verwenden
 Use die in combination with Ergocrimp basis hand tool PN 539635-1

Matrize im Karton mit Bedienungsanleitung 412-94294 verpackt
 Die packed in a cardboard with instruction sheet 412-94294

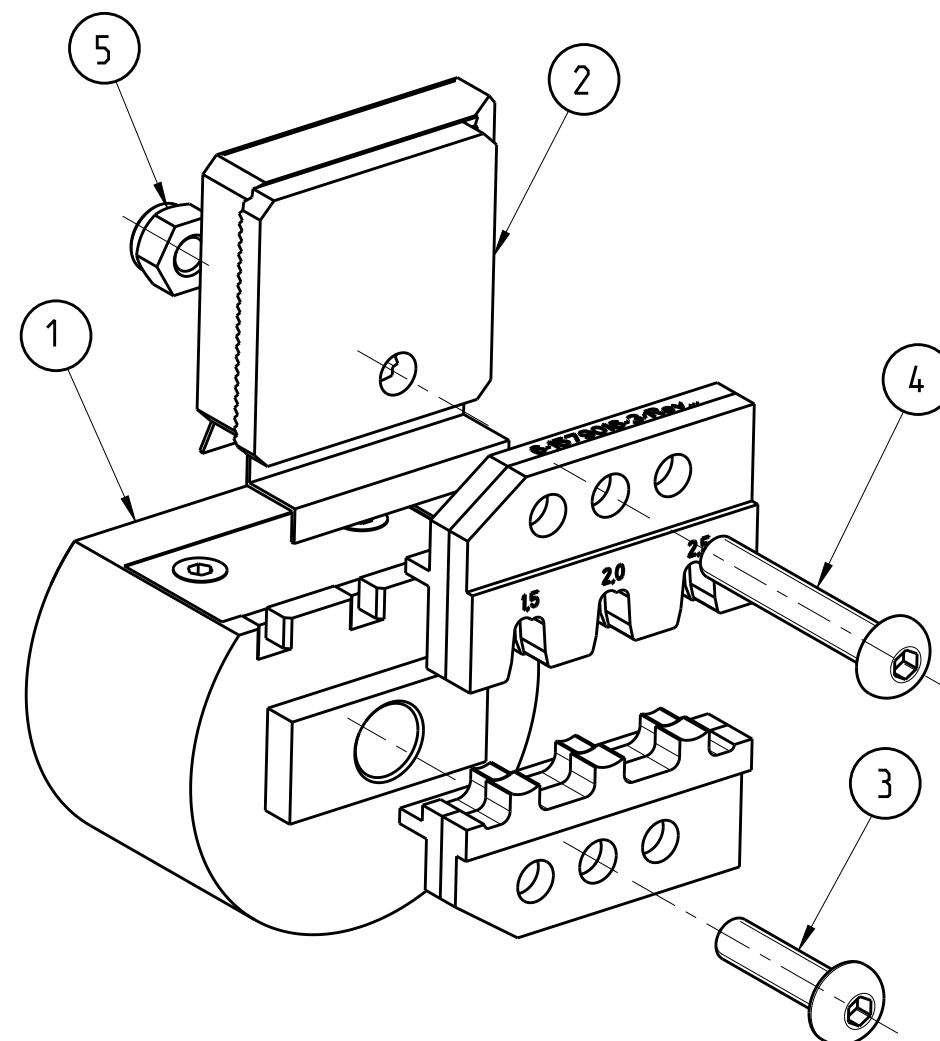

6-1579016-3	1	9-0744015-6	Instruction Sheet	Bedienungsanleitung	6
	1	0-0519024-2	Nut M4 DIN 985	Mutter M4 DIN 985	5
	1	1-0519151-3	Screw M4x25	Schraube M4x25	4
	1	1-0519151-1	Screw M4x16	Schraube M4x16	3
	1	3-1579023-2	Locator Assembly	Drahtanschlag	2
	1	3-1579023-3	Contact Locator	Kontaktpositionierer	1
	QTY Stck	TE PN	Description	Benennung	Pos.

Kontakt	Wire Range	Drahtcrimp / Wire Crimp		Isolationscrimp/Insulationcrimp		Isol.Ø	Betriebsanl.
Contact	AWG (mm ²)	Hoehe/Height mm	Breite/Width mm	Hoehe/Height mm	Breite/Width mm	Ins.Range	Instr.Sheet
928794	1.5	1.69 ±0.05	2.79	-----	3.56 OVL	1.8-2.9	412-94294
	2.0	1.83 ±0.05	2.79	-----	3.56 OVL		
	2.5	1.97 ±0.05	2.79	-----	3.56 OVL		

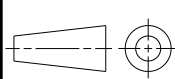
THIS DRAWING IS A CONTROLLED DOCUMENT.		DWN C.Witt 24FEB2016	 TE Connectivity	
		CHK C.Witt 24FEB2016		
DIMENSIONS: mm		TOLERANCES UNLESS OTHERWISE SPECIFIED:		NAME ERGOCRIMP DIE SET Fastin-Faston 2.8 ERGOCRIMP MATRIZE Fastin-Faston 2.8
		0 PLC ± 1 PLC ± 2 PLC ± 3 PLC ± 4 PLC ± ANGLES ±1°		PRODUCT SPEC -
MATERIAL -		FINISH -		APPLICATION SPEC -
		WEIGHT 200 g		SIZE A3
		CUSTOMER DRAWING		CAGE CODE 00779
		SCALE 5:1		DRAWING NO C-6-1579016-3
		SHEET 1 OF 1		RESTRICTED TO -
		REV B		