

| REVISIONS |     |                 |           |       |       |
|-----------|-----|-----------------|-----------|-------|-------|
| REV       | ECO | DESCRIPTION     | DATE      | BY    | APPR  |
| A1        | --  | RELEASE DRAWING | 17/AUG/22 | LUCAS | TOMMY |

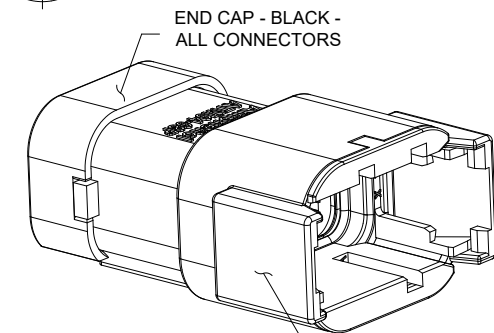

STANDARD MOLDED COLOR IS GREY.  
ADDITIONAL COLORS SHOWN IN PART NUMBER  
CHART ARE AVAILABLE VIA SPECIAL ORDER.

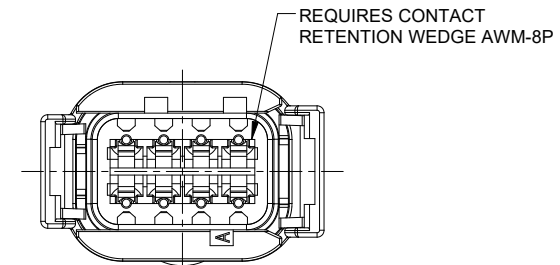
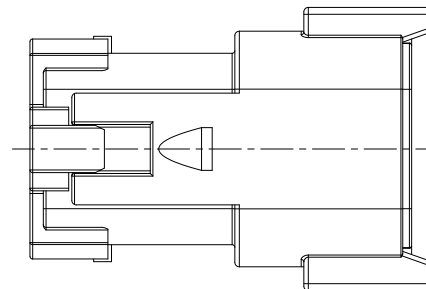
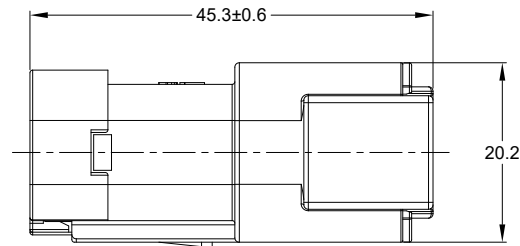
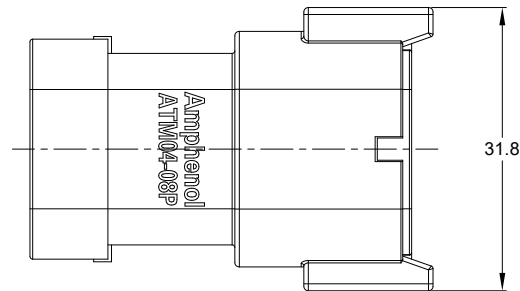
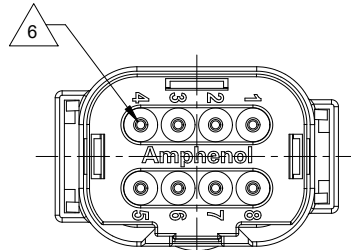

NOTES: UNLESS OTHERWISE SPECIFIED

- MATERIAL:  
HOUSING: THERMOPLASTIC; COLOR: SEE KEY CONFIGURATION  
SEAL RETAINER: THERMOPLASTIC; COLOR: SEE KEY CONFIGURATION  
END CAP: THERMOPLASTIC; COLOR: BLACK  
SEAL: SILICONE RUBBER; COLOR: RED
- MODIFICATIONS: SNAP FIT END CAP
- SPECIFICATIONS:  
3.1 CURRENT RATING: 7.5 AMPS  
3.2 OPERATING TEMPERATURE: -55°C TO +125°C  
3.3 DIELECTRIC WITHSTANDING VOLTAGE: LESS THAN 2 MILLIAMPS CURRENT LEAKAGE @ 1500 VOLTS AC  
3.4 INSULATION RESISTANCE: 1000 MEGOHMS MIN @ 25°C  
3.5 MOISTURE RESISTANCE:  
IP68(IN OF WATER FOR A PERIOD OF 24 HOURS, MATED CONDITION)  
IP69K(MATED CONDITION)  
3.6 MATING CYCLE DURABILITY: 100 CYCLES  
3.7 RoHS COMPLIANT
- MATING PART: ATM06-08SX\* PLUG  
(X = A,B,C,D KEYS, \* = MODIFICATIONS AND COLORS)
- ALL DIMENSIONS ARE FOR REFERENCE USE ONLY

6 CONTACT SIZE AND REAR SEAL WIRE RANGE:

| CONTACT SIZE | MIN. INSUL O.D.   | MAX. INSUL O.D.   | TYPICAL WIRE RANGE                        |
|--------------|-------------------|-------------------|---|
| 20           | 1.35 mm (.053 in) | 3.05 mm (.120 in) | 16 - 22 AWG (1.5 - 0.35 mm <sup>2</sup> ) |

TITLE: 8 POS. RECEPTACLE, PIN, KEYED, ATM SERIES, SNAP FIT  
DWG NO.: ATM04-08PX-SF-1XX  
REV: A1  
SH: 1  
OF: 1

| QUANTITY   | SEE SHEET 2<br>PART NUMBER | DESCRIPTION  | ITEM   |
|--|----------------------------|--|--|
| <b>MATERIALS LIST</b>  |                            |  |  |
| <b>UNLESS OTHERWISE SPECIFIED</b><br>1) All dimensions are in metric(mm).<br>2) Tolerances are as follows:<br>1 PL DEC ±0.30<br>2 PL DEC ±0.15<br>3 PL DEC ±0.08<br>Fractions ±1/64<br>Angles ±1°<br>3) Note reference = |                            | <b>SIGNATURES</b><br>DRAWN: LUCAS CHAI<br>CHECKED: ORION LI<br>ENGINEER:<br>APPROVAL: TOMMY XIE<br>CUSTOMER:   | <b>DATE</b><br>17/AUG/22<br>18/AUG/22<br>18/AUG/22 |
| MATERIAL SPECIFICATIONS:   |                            | <br>Sine Systems - www.amphenol-sine.com<br>44724 Morley Drive<br>Clinton Township, MI 48036   |  |
| PROCESS SPECIFICATIONS:  |                            | 8 POS. RECEPTACLE, PIN, KEYED,<br>ATM SERIES, SNAP FIT   |  |
| NEXT ASSY:   |                            | THIS DRAWING IS SUPPLIED FOR INFORMATION ONLY. DESIGN FEATURES, SPECIFICATIONS AND PERFORMANCE DATA SHOWN HEREON ARE THE PROPERTY OF THE AMPHENOL CORPORATION. NO RIGHTS OF REPRODUCTION ARE IMPLIED. ALL DIMENSIONS ARE SUBJECT TO NORMAL MANUFACTURING VARIATIONS. | <b>SIZE</b><br>B C-                                |
|  |                            | <b>DWG NO.</b><br>ATM04-08PX-SF-1XX  | <b>REVISION</b><br>A1                              |
|  |                            | <b>SCALE</b><br>NONE   | SHEET 1 OF 1                                       |

| REVISIONS |     |                 |           |       |       |
|-----------|-----|-----------------|-----------|-------|-------|
| REV       | ECO | DESCRIPTION     | DATE      | BY    | APPR  |
| A1        | --  | RELEASE DRAWING | 17/AUG/22 | LUCAS | TOMMY |

P/N ATM04-08PA-SF1GY  
KEY-A CONFIGURATION  
STANDARD COLOR: GREY

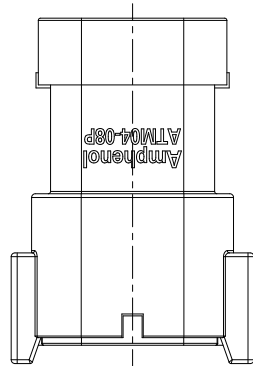

P/N ATM04-08PB-SF1BK  
KEY-B CONFIGURATION  
STANDARD COLOR: BLACK

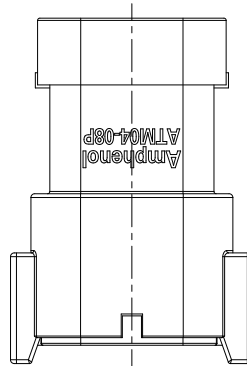

P/N ATM04-08PC-SF1GN  
KEY-C CONFIGURATION  
STANDARD COLOR: GREEN

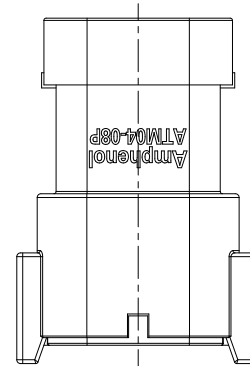

P/N ATM04-08PD-SF1BN  
KEY-D CONFIGURATION  
STANDARD COLOR: BROWN

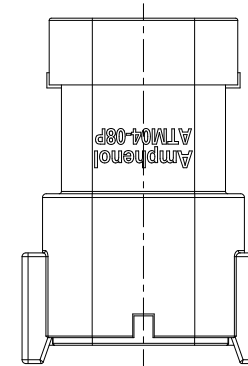

KEYWAY (3) PLACES

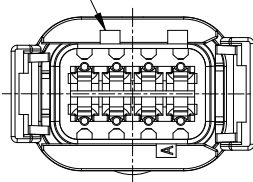

KEYWAY (3) PLACES

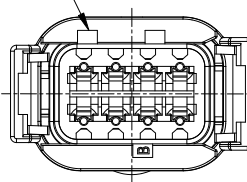

KEYWAY (3) PLACES

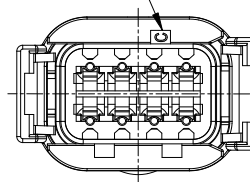

KEYWAY (3) PLACES

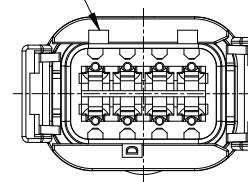

| KEY-A CONFIGURATION |                         |
|---------------------|-------------------------|
| COLOR               | PART NUMBER             |
| <b>* GREY</b>       | <b>ATM04-08PA-SF1GY</b> |
| BLACK               | ATM04-08PA-SF1BK        |
| GREEN               | ATM04-08PA-SF1GN        |
| BROWN               | ATM04-08PA-SF1BN        |

| KEY-B CONFIGURATION |                         |
|---------------------|-------------------------|
| COLOR               | PART NUMBER             |
| GREY                | ATM04-08PB-SF1GY        |
| <b>* BLACK</b>      | <b>ATM04-08PB-SF1BK</b> |
| GREEN               | ATM04-08PB-SF1GN        |
| BROWN               | ATM04-08PB-SF1BN        |

| KEY-C CONFIGURATION |                         |
|---------------------|-------------------------|
| COLOR               | PART NUMBER             |
| GREY                | ATM04-08PC-SF1GY        |
| BLACK               | ATM04-08PC-SF1BK        |
| <b>* GREEN</b>      | <b>ATM04-08PC-SF1GN</b> |
| BROWN               | ATM04-08PC-SF1BN        |

| KEY-D CONFIGURATION |                         |
|---------------------|-------------------------|
| COLOR               | PART NUMBER             |
| GREY                | ATM04-08PD-SF1GY        |
| BLACK               | ATM04-08PD-SF1BK        |
| GREEN               | ATM04-08PD-SF1GN        |
| <b>* BROWN</b>      | <b>ATM04-08PD-SF1BN</b> |

NOTE:

AN ASTERISKS ( \* ) PLACED BEFORE THE COLOR DENOTES THE STANDARD MOLDED COLOR OF THE CONNECTORS SHOWN ABOVE.



OTHER COLORS SHOWN ARE AVAILABLE VIA SPECIAL ORDER.



| QUANTITY   | PART NUMBER | DESCRIPTION   | ITEM  |
|--|-------------|---|---|
| <b>MATERIALS LIST</b>  |             |   |   |
| <b>UNLESS OTHERWISE SPECIFIED</b><br>1) All dimensions are in metric(mm).<br>2) Tolerances are as follows:<br>1 PL DEC ±0.30<br>2 PL DEC ±0.15<br>3 PL DEC ±0.08<br>Fractions ±1/64<br>Angles ±1°<br>3) Note reference =   |             | <b>SIGNATURES</b> <b>DATE</b><br>DRAWN: LUCAS CHAI      17/AUG/22<br>CHECKED: ORION LI      18/AUG/22<br>ENGINEER:<br>APPROVAL: TOMMY XIE      19/AUG/22<br>CUSTOMER: |   |
| MATERIAL SPECIFICATIONS:<br><br><b>WEIGHT: 14g</b><br><br>PROCESS SPECIFICATIONS:<br><br>NEXT ASSY:  |             | <br>Sine Systems - www.amphenol-sine.com<br>44724 Morley Drive<br>Clinton Township, MI 48036<br><br><b>8 POS. RECEPTACLE, PIN, KEYED, ATM SERIES, SNAP FIT</b>        |   |
| THIS DRAWING IS SUPPLIED FOR INFORMATION ONLY. DESIGN FEATURES, SPECIFICATIONS AND PERFORMANCE DATA SHOWN HEREON ARE THE PROPERTY OF THE AMPHENOL CORPORATION. NO RIGHTS OF REPRODUCTION ARE IMPLIED. ALL DIMENSIONS ARE SUBJECT TO NORMAL MANUFACTURING VARIATIONS. |             | <b>SIZE</b><br><b>B C-</b>  | <b>DWG NO.</b><br><b>ATM04-08PX-SF1XX</b><br><b>REVISION</b><br><b>A1</b> |
| <b>SCALE</b><br>NONE   |             | <b>SHEET</b> 2 <b>OF</b> 2  |   |





TITLE: 8 POS. RECEPTACLE, PIN, KEYED, ATM SERIES, SNAP FIT  
DWG NO.: ATM04-08PX-SF1XX  
REV: A1  
SH: 2  
OF: 2

# ATM Series™ - Contact Size 20 Options



| Machined Contacts, Sockets & Pins |  |      |       |          |
|-----------------------------------|--|------|-------|----------|
| Part Number                       | Description                            | Size | AWG   | Type     |
| AT60-010-2031                     | Male Contact - Pin, Gold-plated        | 20   | 16-18 | Machined |
| AT62-005-20141                    | Female Contact - Socket, Gold-plated   | 20   | 16-18 | Machined |
| AT60-010-20141                    | Male Contact - Pin, Nickel-plated      | 20   | 16-18 | Machined |
| AT62-005-2031                     | Female Contact - Socket, Nickel-plated | 20   | 16-18 | Machined |
| AT60-202-2031                     | Male Contact - Pin, Gold-plated        | 20   | 20-22 | Machined |
| AT62-201-2031                     | Female Contact - Socket, Gold-plated   | 20   | 20-22 | Machined |
| AT60-202-20141                    | Male Contact - Pin, Nickel-plated      | 20   | 20-22 | Machined |
| AT62-201-20141                    | Female Contact - Socket, Nickel-plated | 20   | 20-22 | Machined |

| Tooling - Machined Contacts   |             |   |
|---|-------------|---|
| Part  | Part Number | Description   |
|  | CA-5D12     | Universal Hand Crimp Tool, Size 12/16/20 (Machined contacts only) |
|  | CA-5E12     | Pneumatic Crimp Tool, Size 12/16/20 (Machined contacts only)      |

| Contact Removal Tools   |               |   |
|---|---------------|---|
| Part  | Part Number   | Description   |
|  | ATRT-100      | Used for removal of contacts for A Series™ products |
|  | AT11-240-2005 | Contact Removal Tool, Plastic, Size 20              |

| Sealing Plugs   |                   |  |
|---|-------------------|--|
| Part  | Part Number       | Description                                      |
|  | AT13-204-2005     | Sealing Plug, Size 20, White                     |
|  | AT13-204-2005-SR  | Sealing Plug, Size 20, SR01 Series, Black        |
|  | ATM13-217-2005    | Locking Sealing Plug, Size 20, Grey              |
|  | ATM13-217-2005-SR | Locking Sealing Plug, Size 20, SR01 Series, Blue |

| Stamped & Formed Contacts, Sockets & Pins |  |      |       |                  |
|---|--|------|-------|------------------|
| Part Number                               | Description                            | Size | AWG   | Type             |
| AT60-20-0144                              | Male Contact - Pin, Gold-plated        | 20   | 16-22 | Stamped & Formed |
| AT62-20-0144                              | Female Contact - Socket, Gold-plated   | 20   | 16-22 | Stamped & Formed |
| AT60-20-0244                              | Male Contact - Socket, Gold-plated     | 20   | 16-22 | Stamped & Formed |
| AT62-20-0244                              | Female Contact - Socket, Gold-plated   | 20   | 16-22 | Stamped & Formed |
| AT60-20-0122                              | Male Contact - Pin, Nickel-plated      | 20   | 16-22 | Stamped & Formed |
| AT62-20-0122                              | Female Contact - Socket, Nickel-plated | 20   | 16-22 | Stamped & Formed |
| AT60-20-0222                              | Male Contact - Socket, Nickel-plated   | 20   | 16-22 | Stamped & Formed |
| AT62-20-0222                              | Female Contact - Socket, Nickel-plated | 20   | 16-22 | Stamped & Formed |
| AT60-20-0277                              | Male Contact - Socket, Tin-plated      | 20   | 16-22 | Stamped & Formed |
| AT62-20-0277                              | Female Contact - Socket, Tin-plated    | 20   | 16-22 | Stamped & Formed |
| AT60-20-0422                              | Male Contact - Socket, Nickel-plated   | 20   | 20-22 | Stamped & Formed |
| AT62-20-0444                              | Female Contact - Socket, Gold-plated   | 20   | 20-22 | Stamped & Formed |

| Tooling - Stamped & Formed Contacts   |             |   |
|---|-------------|---|
| Part  | Part Number | Description   |
|  | MF3-3974    | Crimp Die - Size 20 (S&F contacts only)                       |
|   | MF3-3976    | Crimp Die - Size 20 (S&F contacts only) 20-22AWG -04XX Series |
|   | MF3-3978    | Crimp Die - Size 20 (S&F contacts only) 20-22AWG -02XX Series |
|  | ATT-20-00   | Hand Crimp Tool - Size 20, 20AWG (S&F contacts only)          |