

PART NUMBER	REVISION	DESCRIPTION	FEED TYPE
2266120-1	K	FINE CRIMP HEIGHT ADJUST	MECHANICAL
2266120-2	K	FINE CRIMP HEIGHT ADJUST	PNEUMATIC
5-2266120-1	K	SEAL STRIPPER CRIMPER TERMINATING UNIT	MECHANICAL
5-2266120-2	K	SEAL STRIPPER CRIMPER TERMINATING UNIT	PNEUMATIC
7-2266120-1	K	MECHANICAL AND CRIMP TOOLING KIT	MECHANICAL
7-2266120-2	K	PNEUMATIC AND CRIMP TOOLING KIT	PNEUMATIC
7-2266120-7	D	CRIMP TOOLING KIT	-
7-2266120-8	D	APPLICATOR CONVERSION KIT	-

ATLANTIC VERSION TERMINATOR INTERFACE ADAPTER

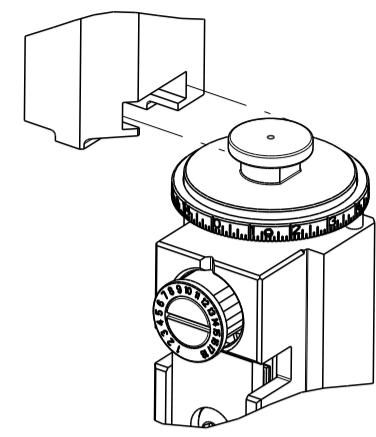

APPLICATOR DATA		
CRIMP	SIZE	TYPE
WIRE	1.75 mm [.069]	F
INSUL	1.32 mm [.052]	O

APPLICATOR INSTRUCTIONS
408-35042

APPLICATOR CONVERSION KITS	
PART NUMBER	INSULATION DIAMETER RANGE
7-2266116-8	Ø2.74-3.18mm [.108-.125]
7-2266117-8	Ø2.31-2.72mm [.091-.107]
7-2266118-8	Ø1.91-2.29mm [.075-.090]
7-2266119-8	Ø1.62-2.16mm [.063-.085]
7-2266120-8	Ø1.27-1.57mm [.050-.062]

TERMINAL DATA: DEUTSCH TERMINAL DEUTSCH CRIMP SPECIFICATION			
TERMINAL NAME: STAMPED CONTACT PIN SIZE 20			
WIRE STRIP LENGTH	INSULATION DIAMETER RANGE		
3.81-5.09 mm [.150-.200 IN]	Ø1.27-1.57 mm [.050-.062 IN]	114-151003 Rev A1	
TERMINALS APPLIED			
TE TERMINAL	DEUTSCH TERMINAL	TE TERMINAL	DEUTSCH TERMINAL
1572032-3	1060-20-0222	1572032-4	1060-20-0244
1572032-8	1060-20-0277		

TERMINAL DATA: DEUTSCH TERMINAL DEUTSCH CRIMP SPECIFICATION			
TERMINAL NAME: STAMPED CONTACT SOCKET SIZE 20			
WIRE STRIP LENGTH	INSULATION DIAMETER RANGE		
3.81-5.09 mm [.150-.200 IN]	Ø1.27-1.57 mm [.050-.062 IN]	114-151003 Rev A1	
TERMINALS APPLIED			
TE TERMINAL	DEUTSCH TERMINAL	TE TERMINAL	DEUTSCH TERMINAL
286680-3	1062-20-0222	286680-4	1062-20-0244
1-286680-1	1062-20-0277		

WIRE SIZE	CRIMP HEIGHT mm [INCH]	CRIMP HEIGHT REFERENCE SETTING
0.75mm2	1.22+0.03/-0.05 [.048+.001/-0.002]	5.9
0.60mm2	1.07+0.03/-0.05 [.042+.001/-0.002]	7.4
20 AWG	0.99+0.03/-0.05 [.039+.001/-0.002]	8.2
0.50mm2	0.97+0.03/-0.05 [.038+.001/-0.002]	8.4
22 AWG	0.94+0.03/-0.05 [.037+.001/-0.002]	8.7
0.35mm2	0.94+0.03/-0.05 [.037+.001/-0.002]	8.7

- 1 RECOMMENDED SPARE PARTS
- 2 REFER TO SUPPLIED INSTRUCTION SHEET FOR CLEANING, LUBRICATION AND STORAGE OF APPLICATOR.
- 3 APPLY PART NUMBER 2-23419-6 LOCTITE TO THREADS OF ITEM 242. APPLY PART NUMBER 1-23419-5 LOCTITE TO THREADS OF ITEM 180.
- 4 CRIMP HEIGHT REFERENCE SETTING WAS THE SETTING USED WHEN THE APPLICATOR WAS QUALIFIED AT THE FACTORY. ADJUSTMENT MAY BE NECESSARY WHEN RUNNING APPLICATOR IN THE FIELD.
- 5 TERMINAL LUBRICANT IS RECOMMENDED.
- 6 UNLESS SPECIFIED OTHERWISE TORQUE VALUES SHALL BE USED PER DOCUMENT, 101-35000.
- 7 SEE APPROPRIATE APPLICATOR LOG SHEETS FOR APPLIED TERMINALS, WIRE RANGE AND MEMORY CHIP.

***WARNING**
ON INSTALLATION, SET WIRE DISC TO CRIMP HEIGHT REFERENCE SETTING FOR LARGEST WIRE SIZE. CRIMP HEIGHT REFERENCE SETTINGS GREATER THAN THE VALUE SHOWN MAY CAUSE DAMAGE TO THE CRIMP TOOLING. REFER TO THE INSTRUCTION SHEET FOR PROPER SETUP AND ADJUSTMENTS.

ATLANTIC VERSION
Shown on sheets 1 of 4 & 2 of 4
(Pacific version shown on sheets 3 of 4 & 4 of 4)

LOC	DIST	REVISIONS					
		P	LTN	DESCRIPTION	DATE	OWN	APPV
A	66	H		ECR-20-012488	03SEP2020	JWC	TE
		J		ECR-20-013127	16SEP2020	FZ	RR
		K		ECR-22-148085	01AUG2022	TB	GB
		K1		ECR-22-148102	01AUG2022	TB	GB

-	-	-	-	1	1	-	-	1803515-3	RAM ASSEMBLY, SF ATLANTIC	293
-	-	-	-	1	1	-	-	2-1803583-1	APPLICATOR BASIC ASSEMBLY, SF	292
-	-	2	2	2	2	2	2	2168083-1	SCR, SKT HD CAP, RoHS, M3 X 8.0	269
-	-	1	1	1	1	1	1	2-1633782-0	FENCE	267
-	-	1	-	1	-	1	-	2119641-1	FEED CAM, AIR FEED	248
-	-	1	1	1	1	1	1	2119082-9	CAM, SNAIL, INSULATION ADJUSTMENT	244
-	-	1	1	1	1	1	1	2079764-1	WASHER, WAVE SPRING, CREST-TO-CREST	243
-	-	1	1	1	1	1	1	2119083-1	RETAINER, INSULATION DIAL	242
-	-	1	1	1	1	1	1	7-18023-7	SCR, SKT HD CAP M3 X 4.0	241
-	-	-	1	-	1	-	-	2119580-1	MECHANICAL FEED ASSEMBLY	239
-	-	1	-	1	-	1	-	2844940-1	AIR FEED MODULE	238
-	-	-	-	1	1	-	-	4-1722335-3	STRIPPER, SIDE FEED	182
-	-	-	-	1	1	-	-	1-5018030-0	NUT, HEX, REG, RoHS, M3.5	181
-	-	-	-	1	1	-	-	1-1752354-8	STANDOFF,HOLD-DOWN	180
-	-	-	-	1	1	-	-	993111-1	PIN, SLOTTED SPRING 3.0 X 20.0	177
-	-	-	-	1	1	-	-	5-22280-0	SPRING, COMPRESSION	176
-	-	-	-	1	1	-	-	1752353-3	GUIDE PIN,HOLDDOWN	175
-	-	-	-	1	1	-	-	1901680-2	GUIDE PIN,HOLDDOWN	174
-	-	REF	REF	REF	REF	REF	REF	994970-2	COUNTER, MAGNETIC	164
-	-	1	1	1	1	1	1	1-18028-2	WASHER, FLAT, REG M4	119
-	-	1	1	1	1	1	1	2119955-1	ASSY, LUBRICATOR, SIDE FEED	113
-	-	1	1	1	1	1	1	2844908-1	SCREW, LOCKING	99
-	-	1	1	1	1	1	1	2844907-1	POST, LOCKING	98
-	-	1	1	1	1	1	1	455888-7	SPACER, CRIMPER	82
1	-	-	-	-	-	-	-	2266120	PRINT, APPLICATOR LOG SHEET	72
-	-	1	1	1	1	1	1	1803607-3	DOCUMENTATION PACKAGE	71
-	-	1	1	1	1	1	1	2119791-9	DEPRESSOR, WIRE	70
-	-	1	1	1	1	1	1	2119740-1	TAG, IDENTIFICATION	67
-	-	2	2	2	2	2	2	2168078-1	SCREW, DRIVE, RH, RoHS, 2 x .188	66
-	-	1	1	1	1	1	1	2168083-2	SCR, SKT HD CAP, RoHS, M4 X 8.0	60
-	-	1	1	1	1	1	1	5-18022-5	SCR, HEX HD CAP, M4 X 6.0	59
-	-	1	1	1	1	1	1	1338685-1	PAWL, FEED	56
-	-	4	4	4	4	4	4	2168083-3	SCR, SKT HD CAP, RoHS, M4 X 12.0	54
-	-	2	2	2	2	2	2	1-2168083-0	SCR, SKT HD CAP, RoHS, M4 X 10	53
-	-	1	1	1	1	1	1	1803382-6	HOLD DOWN, SPRING LOADED	50
-	-	1	2	1	2	1	2	18023-9	SCR, SKT HD CAP M4 X 6.0	49
-	-	-	1	-	1	-	1	2119652-1	FEED CAM, PRE FEED	48
-	-	-	1	-	1	-	1	2119653-1	FEED CAM, POST FEED	47
-	-	1	1	-	-	1	1	1803583-9	APPLICATOR BASIC ASSEMBLY, SF	46
-	-	1	1	-	-	1	1	1803515-1	RAM ASSEMBLY, SF ATLANTIC	44
-	-	1	1	1	1	1	1	1803602-1	SCR, BHSC, RoHS (M8 X 25)	41
-	-	1	1	1	1	1	1	2-1752356-0	SUPPORT, TERMINAL	34
-	-	2	2	2	2	2	2	2079383-5	SCR, BHSC, RoHS (M4 X 20)	33
-	-	2	2	2	2	2	2	2-2844962-8	SPACER, CYLINDRICAL, STRIP GUIDE	30
-	-	1	1	1	1	1	1	2844992-1	ASSEMBLY, STRIP GUIDE	29
-	-	1	1	1	1	1	1	1320928-2	STRIP GUIDE	24
-	-	1	1	-	-	1	1	2168083-2	SCR, SKT HD CAP, RoHS, M4 X 8.0	21
-	-	2	2	1	1	2	2	1-18028-2	WASHER, FLAT, REG M4	20
-	-	1	1	-	-	1	1	2119533-1	STRIPPER, SIDE FEED	19
-	-	1	1	1	1	1	1	2119806-1	INSERT, SHEAR	13
-	-	1	1	1	1	1	1	3-22280-3	SPRING, COMPRESSION	12
-	-	1	1	1	1	1	1	1-356885-4	STOP, SHEAR	11
-	-	1	1	1	1	1	1	2119805-1	SHEAR HOLDER, FRONT	10
-	-	1	1	1	1	1	1	1803095-6	FLOATING SHEAR, FRONT	9
1	1	2	2	1	1	1	1	1-1803293-6	ANVIL, COMBINATION DEUTSCH STYLE	8
-	-	1	1	1	1	1	1	2-240641-8	SPACER	7
-	-	-	-	-	-	-	-	-	-	6
-	-	1	1	1	1	1	1	1-2119757-2	DEPRESSOR, SHEAR	5
-	-	1	1	1	1	1	1	238011-9	BLOCK, CRIMPER SPACER	4
1	1	2	2	1	1	1	1	6-1803019-3	CRIMPER, INSULATION O	3
-	-	1	1	1	1	1	1	455888-8	SPACER, CRIMPER	2
-	-	1	2	2	1	1	1	1803364-2	CRIMPER, WIRE PREMIUM	1

DIMENSIONS:	TOLERANCES UNLESS OTHERWISE SPECIFIED:	OWN	CHK	DATE	NAME	SIZE	CAGE CODE	DRAWING NO	RESTRICTED TO
mm	0 PLC ± 1 PLC ± 2 PLC ± 3 PLC ± 4 PLC ± ANGLES ±	R. KNEPPER	G. BAILEY	17-Oct-13	M. CLIFFORD	A1	00779	2266120	-
MATERIAL:	FINISH:	APPROVED:		DATE:	NAME:	SCALE:		SHEET:	REV:
		Customer Accessible Production Drawing		17-Oct-13	M. CLIFFORD	1:2		1 of 4	K1

LOC	DIST	REVISIONS					
A	66	P	LYN	DESCRIPTION	DATE	OWN	APVD
		-		SEE SHEET 1	-	-	-

FEED TYPE MECHANICAL

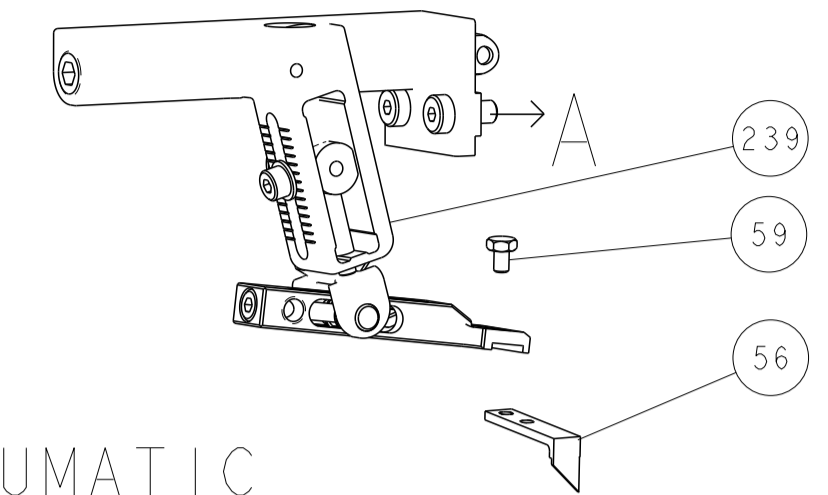

PNEUMATIC

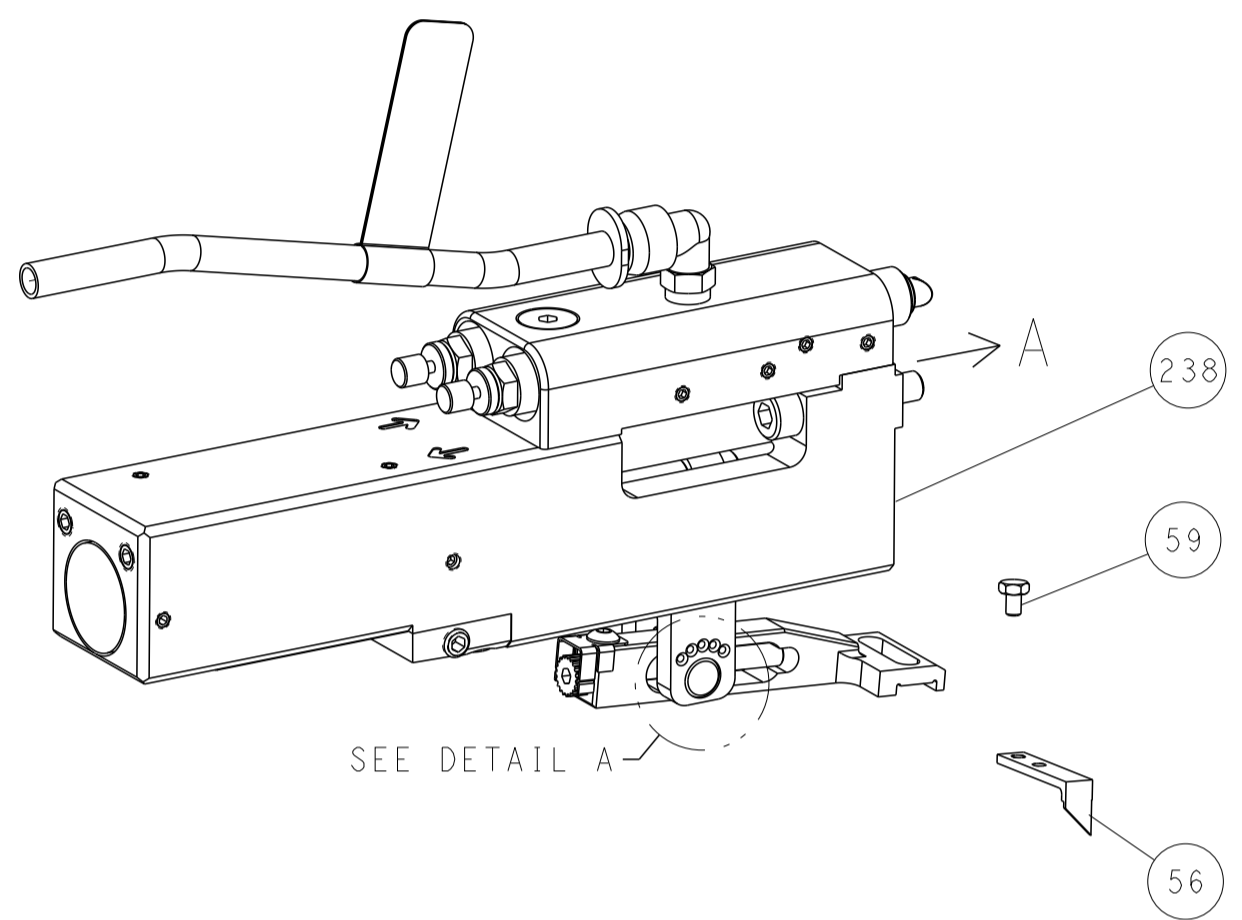

FEED SPRING SETTING POSITION (SHOWN FROM REAR SIDE)



DETAIL A

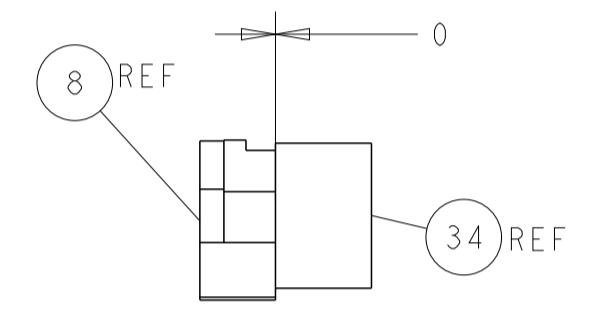
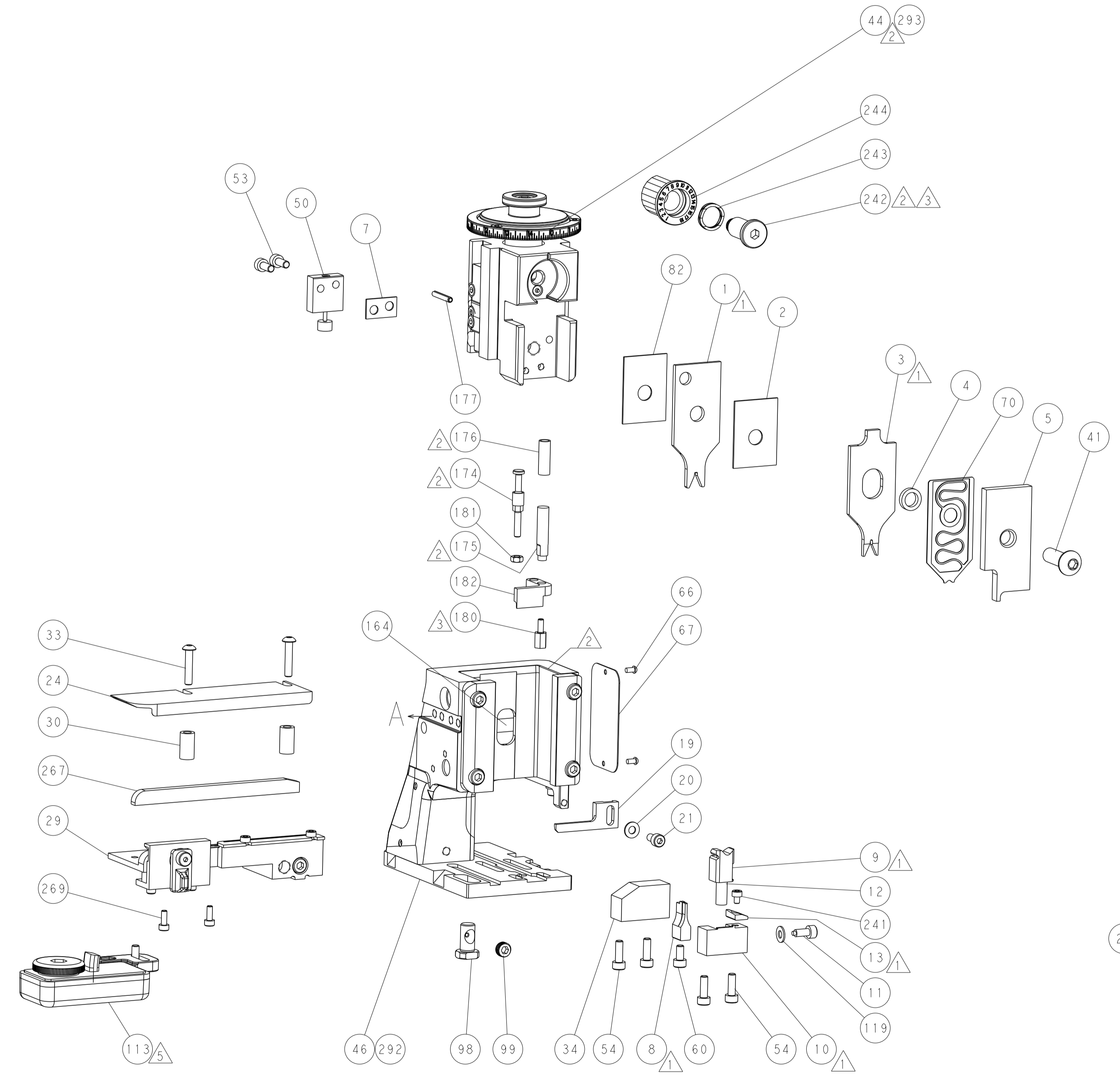

TERMINAL SUPPORT LOCATION

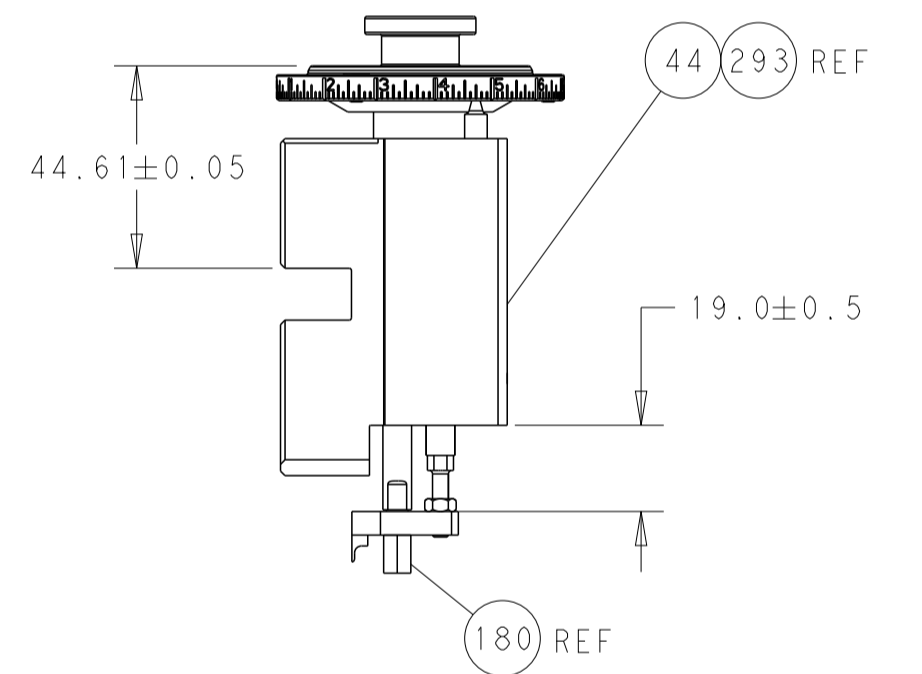

RAM AND HOLDDOWN SET-UP

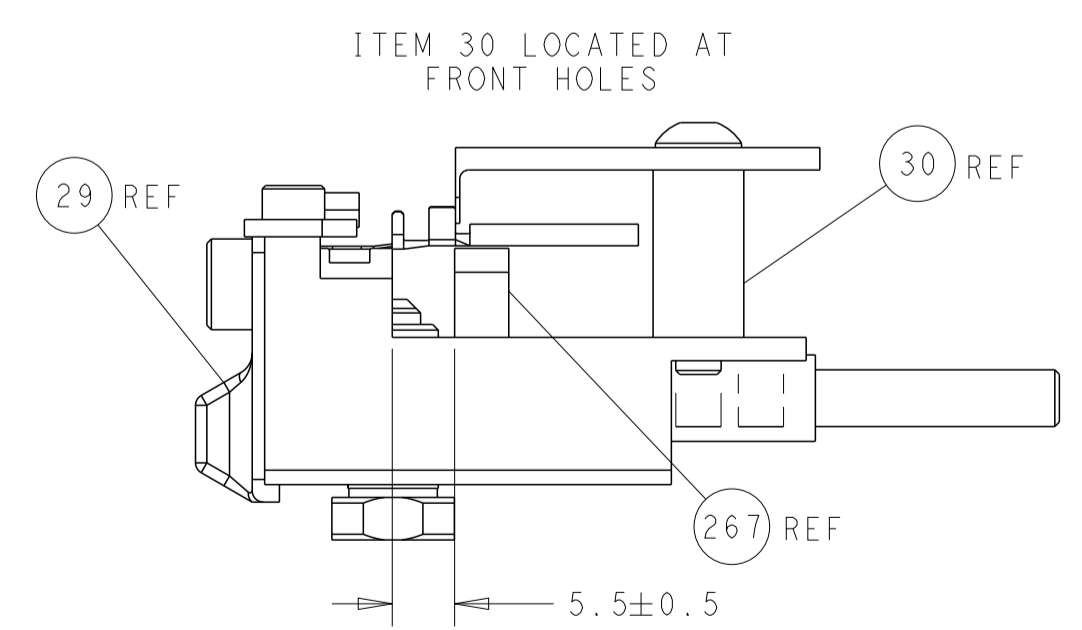

FEED TRACK POSITION GUIDE BY WIRE BARREL

CAM POSITIONS

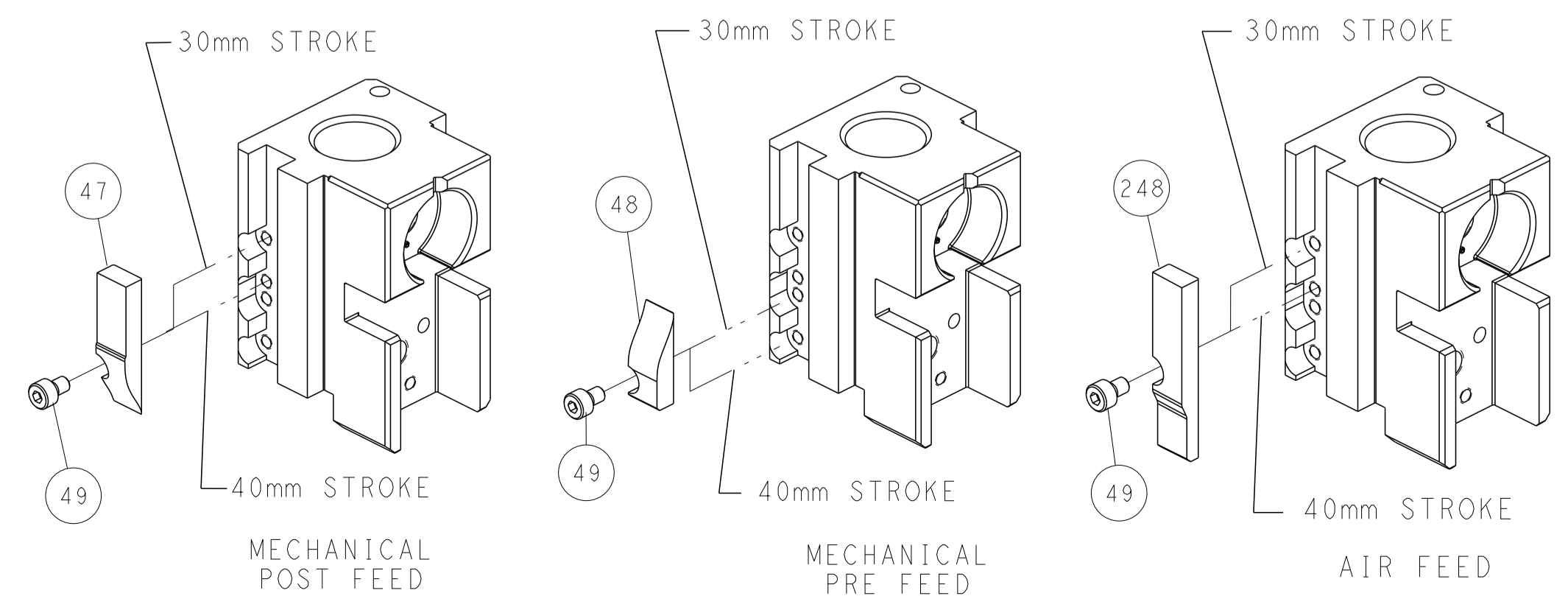

ATLANTIC VERSION
 Shown on sheets 1 of 4 & 2 of 4
 (Pacific version shown on sheets 3 of 4 & 4 of 4)

<small>THIS DRAWING IS UNPUBLISHED. RELEASED FOR PUBLICATION BY TYCO ELECTRONICS CORPORATION. ALL RIGHTS RESERVED.</small>		DWN: R. KNEPPER 17-Oct-13 CHK: G. BAILEY 17-Oct-13 APVD: M. CLIFFORD 17-Oct-13	NAME: Ocean Side Feed Applicator SIZE: A1 CAGE CODE: 00779 DRAWING NO: 2266120	TE Connectivity Harrisburg, PA 17105-3608
DIMENSIONS: mm TOLERANCES UNLESS OTHERWISE SPECIFIED: 0 PLC ± 1 PLC ± 2 PLC ± 3 PLC ± 4 PLC ± ANGLES FINISH	MATERIAL: - FINISH: -	WEIGHT: - SCALE: 1:2	SHEET 2 OF 4 REV K1	RESTRICTED TO: -

PART NUMBER	REVISION	DESCRIPTION	FEED TYPE
2-2266120-1	K	FINE CRIMP HEIGHT ADJUST	MECHANICAL
2-2266120-2	K	FINE CRIMP HEIGHT ADJUST	PNEUMATIC
7-2266120-7	D	CRIMP TOOLING KIT	-
7-2266120-8	D	APPLICATOR CONVERSION KIT	-

PACIFIC VERSION TERMINATOR
 INTERFACE ADAPTER



APPLICATOR DATA

CRIMP	SIZE	TYPE
WIRE	1.75 mm [.069]	F
INSUL	1.32 mm [.052]	O

APPLICATOR INSTRUCTIONS
 408-35042

APPLICATOR CONVERSION KITS

PART NUMBER	INSULATION DIAMETER RANGE
7-2266116-8	Ø 2.74-3.18mm [.108-.125]
7-2266117-8	Ø 2.31-2.72mm [.091-.107]
7-2266118-8	Ø 1.91-2.29mm [.075-.090]
7-2266119-8	Ø 1.62-2.16mm [.063-.085]
7-2266120-8	Ø 1.27-1.57mm [.050-.062]

TERMINAL DATA: DEUTSCH TERMINAL DEUTSCH CRIMP SPECIFICATION

TERMINAL NAME: STAMPED CONTACT PIN SIZE 20

WIRE STRIP LENGTH	INSULATION DIAMETER RANGE
3.81-5.09 mm [1.50-.200 IN]	Ø 1.27-1.57 mm [.050-.062 IN]

TERMINAL APPLICATION SPECIFICATION 114-151003 Rev A1

TERMINALS APPLIED

TE TERMINAL	DEUTSCH TERMINAL	TE TERMINAL	DEUTSCH TERMINAL
1572032-3	1060-20-0222	1572032-4	1060-20-0244
1572032-8	1060-20-0277		

TERMINAL DATA: DEUTSCH TERMINAL DEUTSCH CRIMP SPECIFICATION

TERMINAL NAME: STAMPED CONTACT SOCKET SIZE 20

WIRE STRIP LENGTH	INSULATION DIAMETER RANGE
3.81-5.09 mm [1.50-.200 IN]	Ø 1.27-1.57 mm [.050-.062 IN]

TERMINAL APPLICATION SPECIFICATION 114-151003 Rev A1

TERMINALS APPLIED

TE TERMINAL	DEUTSCH TERMINAL	TE TERMINAL	DEUTSCH TERMINAL
286680-3	1062-20-0222	286680-4	1062-20-0244
1-286680-1	1062-20-0277		

WIRE SIZE	CRIMP HEIGHT mm [INCH]	CRIMP HEIGHT REFERENCE SETTING
0.75mm2	1.22+0.03/-0.05 [.048+.001/-0.002]	5.9
0.60mm2	1.07+0.03/-0.05 [.042+.001/-0.002]	7.4
20 AWG	0.99+0.03/-0.05 [.039+.001/-0.002]	8.2
0.50mm2	0.97+0.03/-0.05 [.038+.001/-0.002]	8.4
22 AWG	0.94+0.03/-0.05 [.037+.001/-0.002]	8.7
0.35mm2	0.94+0.03/-0.05 [.037+.001/-0.002]	8.7

- RECOMMENDED SPARE PARTS
- REFER TO SUPPLIED INSTRUCTION SHEET FOR CLEANING, LUBRICATION AND STORAGE OF APPLICATOR.
- APPLY PART NUMBER 2-23419-6 LOCTITE TO THREADS OF ITEM 242.
- CRIMP HEIGHT REFERENCE SETTING WAS THE SETTING USED WHEN THE APPLICATOR WAS QUALIFIED AT THE FACTORY. ADJUSTMENT MAY BE NECESSARY WHEN RUNNING APPLICATOR IN THE FIELD.
- TERMINAL LUBRICANT IS RECOMMENDED.
- UNLESS SPECIFIED OTHERWISE TORQUE VALUES SHALL BE USED PER DOCUMENT, 101-35000.
- SEE APPROPRIATE APPLICATOR LOG SHEETS FOR APPLIED TERMINALS, WIRE RANGE AND MEMORY CHIP.

***WARNING**
 ON INSTALLATION, SET WIRE DISC TO CRIMP HEIGHT REFERENCE SETTING FOR LARGEST WIRE SIZE. CRIMP HEIGHT REFERENCE SETTINGS GREATER THAN THE VALUE SHOWN MAY CAUSE DAMAGE TO THE CRIMP TOOLING. REFER TO THE INSTRUCTION SHEET FOR PROPER SETUP AND ADJUSTMENTS.

LOC: A DIST: 66

REV	DATE	DESCRIPTION	DATE	BY	APPD
-	-	SEE SHEET 1	-	-	-

-	-	2	2	2168083-1	SCR, SKT HD CAP, RoHS, M3 X 8.0	269
-	-	1	1	2-1633782-0	FENCE	267
-	-	1	1	2119082-9	CAM, SNAIL, INSULATION ADJUSTMENT	244
-	-	1	1	2079764-1	WASHER, WAVE SPRING, CREST-TO-CREST	243
-	-	1	1	2119083-1	RETAINER, INSULATION DIAL	242
-	-	1	1	7-18023-7	SCR, SKT HD CAP M3 X 4.0	241
-	-	-	1	2119580-1	MECHANICAL FEED ASSEMBLY	239
-	-	1	-	2844940-1	AIR FEED MODULE	238
-	-	REF	REF	994970-2	COUNTER, MAGNETIC	164
-	-	1	-	2119641-2	FEED CAM, AIR FEED	151
-	-	1	1	2168083-8	SCR, SKT HD CAP, RoHS, M4 X 16	144
-	-	4	4	2168083-9	SCR, SKT HD CAP, RoHS, M4 X 20	143
-	-	-	1	2119653-2	FEED CAM, POST FEED	142
-	-	1	1	1-1803583-0	APPLICATOR BASIC ASSEMBLY, SF	141
-	-	1	1	1803516-1	RAM ASSEMBLY, SF PACIFIC	140
-	-	1	1	1-18028-2	WASHER, FLAT, REG M4	119
-	-	1	1	2119955-1	ASSY, LUBRICATOR, SIDE FEED	113
-	-	1	1	2844908-1	SCREW, LOCKING	99
-	-	1	1	2844907-1	POST, LOCKING	98
-	-	1	1	455888-7	SPACER, CRIMPER	82
1	-	-	-	2266120	PRINT, APPLICATOR LOG SHEET	72
-	-	1	1	1803607-3	DOCUMENTATION PACKAGE	71
-	-	1	1	2119791-9	DEPRESSOR, WIRE	70
-	-	1	1	2119740-1	TAG IDENTIFICATION	67
-	-	2	2	2168078-1	SCREW, DRIVE, RH, RoHS, 2 x .188	66
-	-	1	1	5-18022-5	SCR, HEX HD CAP, M4 X 6.0	59
-	-	1	1	1338685-1	PAWL, FEED	56
-	-	2	2	1-2168083-0	SCR, SKT HD CAP, RoHS, M4 X 10	53
-	-	1	1	1803382-6	HOLD DOWN, SPRING LOADED	50
-	-	1	2	18023-9	SCR, SKT HD CAP M4 X 6.0	49
-	-	-	1	2119652-1	FEED CAM, PRE FEED	48
-	-	1	1	1803602-1	SCR, BHSC, RoHS (M8 X 25)	41
-	-	1	1	2-1752356-0	SUPPORT, TERMINAL	34
-	-	2	2	2079383-5	SCR, BHSC, RoHS (M4 X 20)	33
-	-	2	2	2-2844962-8	SPACER, CYLINDRICAL, STRIP GUIDE	30
-	-	1	1	2844992-1	ASSEMBLY, STRIP GUIDE	29
-	-	1	1	1320928-2	STRIP GUIDE	24
-	-	1	1	2168083-2	SCR, SKT HD CAP, RoHS, M4 X 8.0	21
-	-	1	1	1-18028-2	WASHER, FLAT, REG M4	20
-	-	1	1	2119533-1	STRIPPER, SIDE FEED	19
-	-	1	1	2119806-1	INSERT, SHEAR	13
-	-	1	1	3-22280-3	SPRING, COMPRESSION	12
-	-	1	1	1-356885-4	STOP, SHEAR	11
-	-	1	1	2119805-1	SHEAR HOLDER, FRONT	10
-	-	1	1	1803095-6	FLOATING SHEAR, FRONT	9
1	1	1	1	1-1803293-6	ANVIL, COMBINATION DEUTSCH STYLE	8
-	-	1	1	2-240641-8	SPACER	7
-	-	-	-	-	-	6
-	-	1	1	1-2119757-2	DEPRESSOR, SHEAR	5
-	-	1	1	238011-9	BLOCK, CRIMPER SPACER	4
1	1	1	1	6-1803019-3	CRIMPER, INSULATION O	3
-	-	1	1	455888-8	SPACER, CRIMPER	2
-	-	1	1	1803364-2	CRIMPER, WIRE PREMIUM	1

PACIFIC VERSION
 Shown on sheets 3 of 4 & 4 of 4
 (Atlantic version shown on sheets 1 of 4 & 2 of 4)

DIMENSIONS: mm 		TOLERANCES UNLESS OTHERWISE SPECIFIED: 0 PLC ± 1 PLC ± 2 PLC ± 3 PLC ± 4 PLC ± ANGLES ± FINISH		DWN: R. KNEPPER 17-Oct-13 CHK: G. BAILEY 17-Oct-13 APVD: M. CLIFFORD 17-Oct-13 PRODUCT SPEC APPLICATION SPEC WEIGHT: - SCALE: A1 00779 ©=2266120		NAME: Ocean Side Feed Applicator SIZE: - CAGE CODE: - DRAWING NO: - RESTRICTED TO: - Customer Accessible Production Drawing SCALE: 1:2 SHEET 3 OF 4 REV: K1	
--------------------	--	---	--	--	--	---	--

LOC	DIST	REVISIONS					
A	66	P	LTH	DESCRIPTION	DATE	DWN	APVD
		-		SEE SHEET 1			

FEED TYPE MECHANICAL

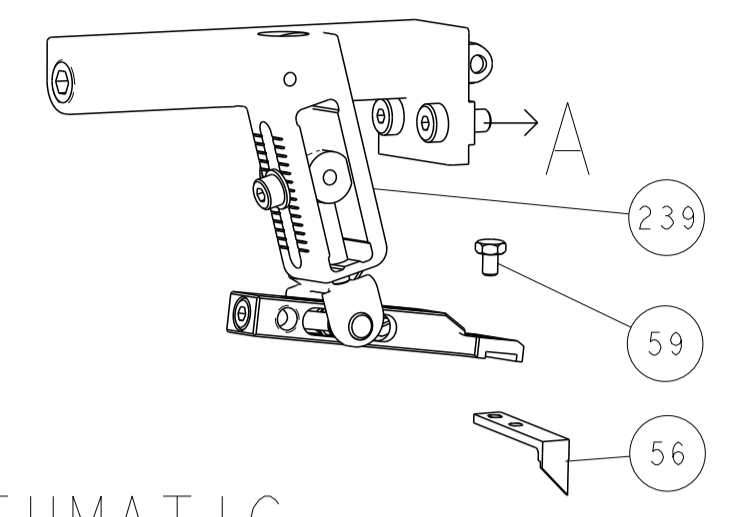

PNEUMATIC

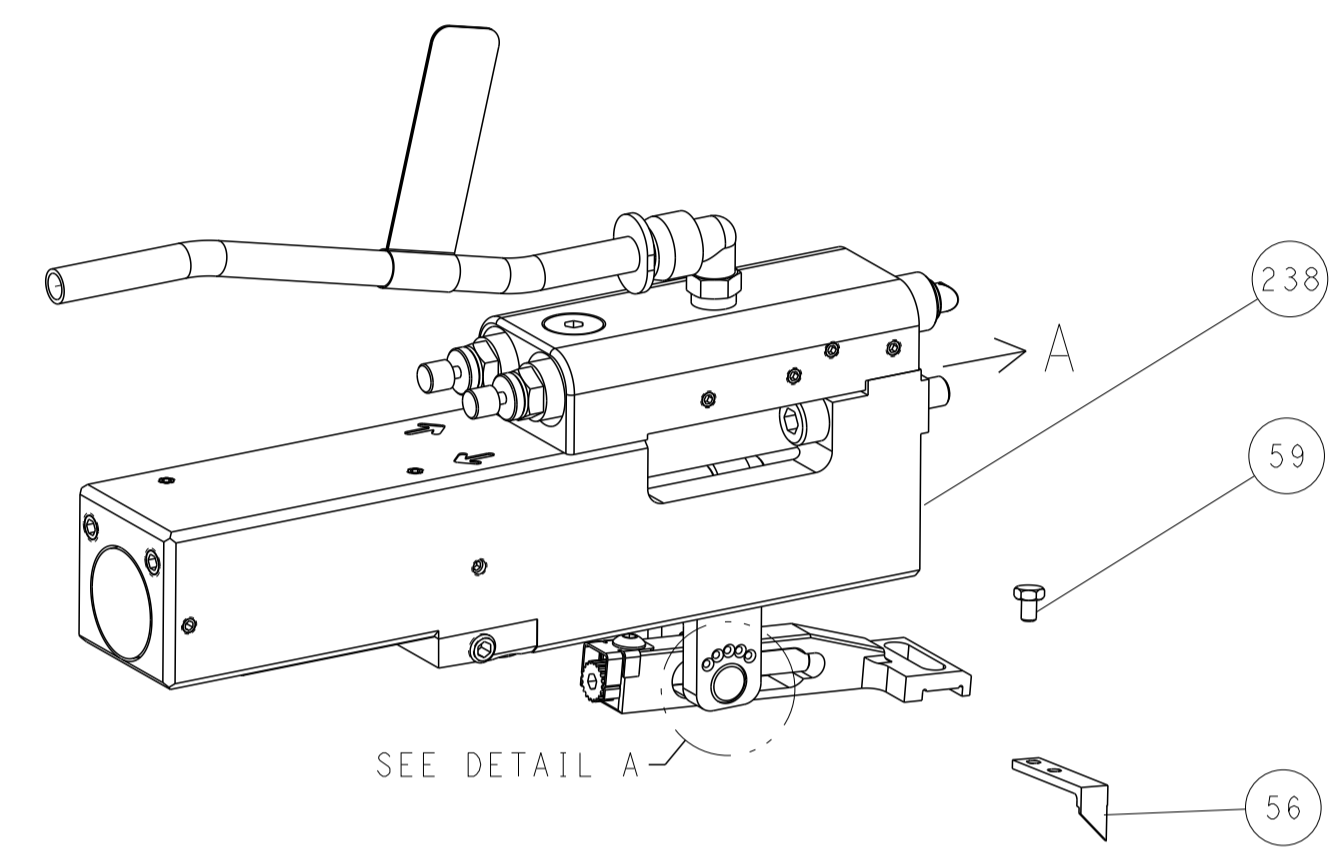

FEED SPRING SETTING POSITION (SHOWN FROM REAR SIDE)



DETAIL A

CAM POSITIONS

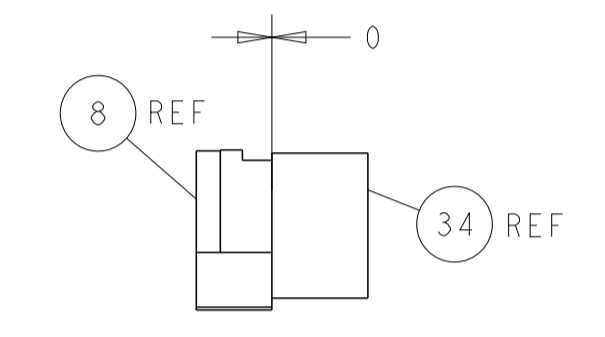
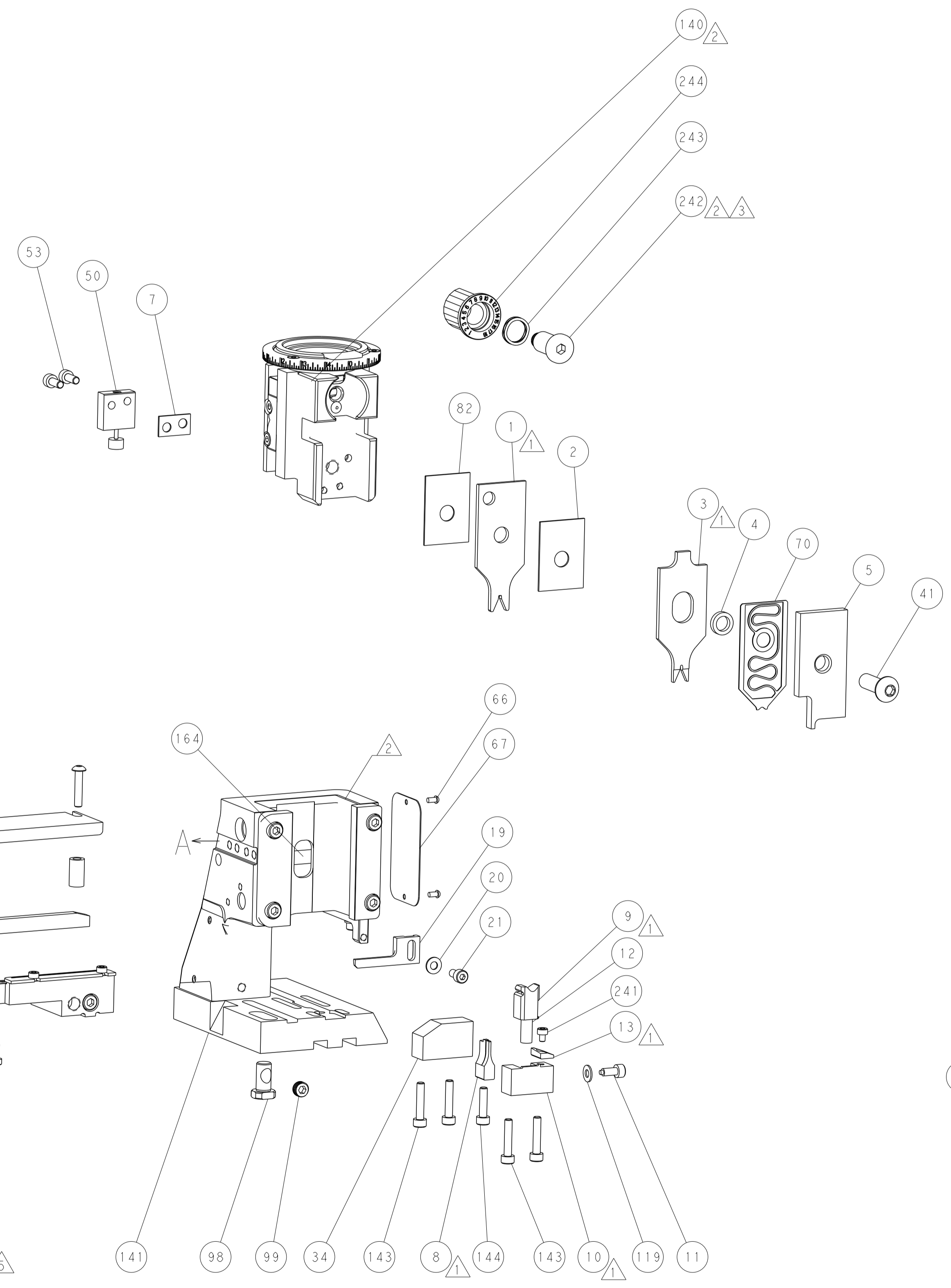
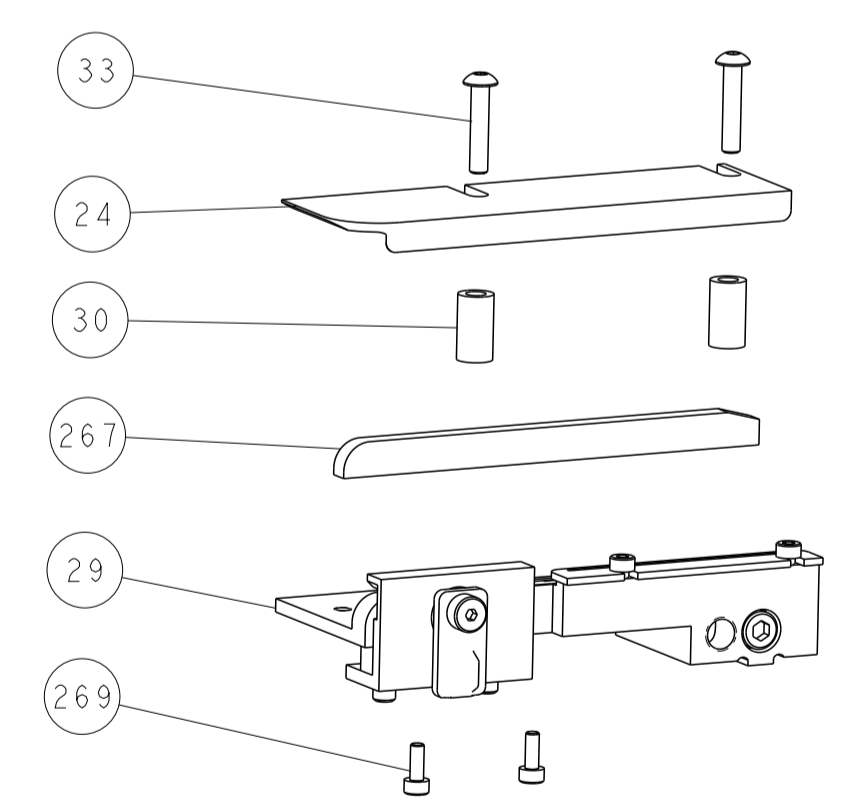
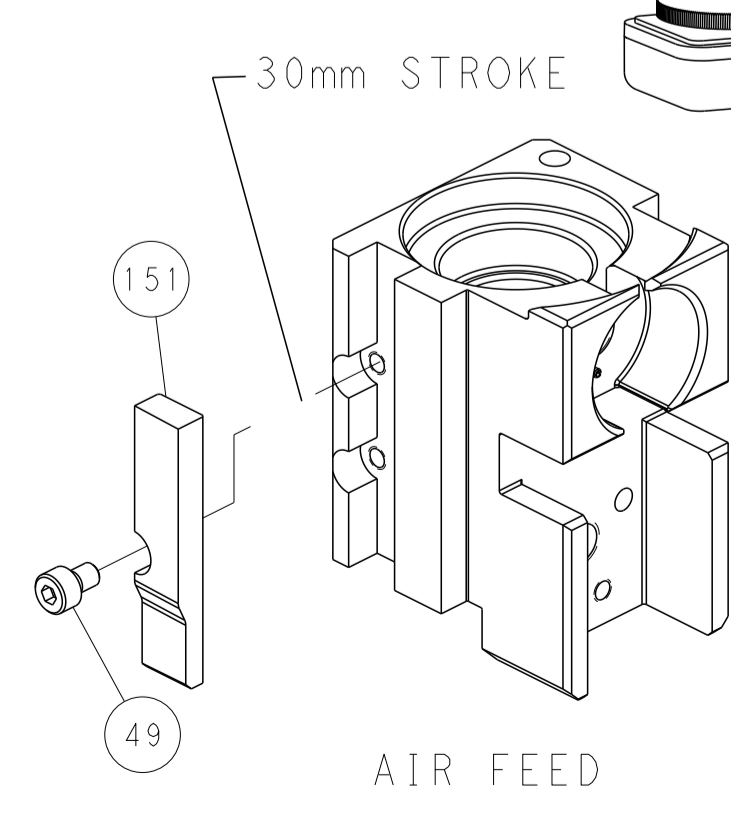
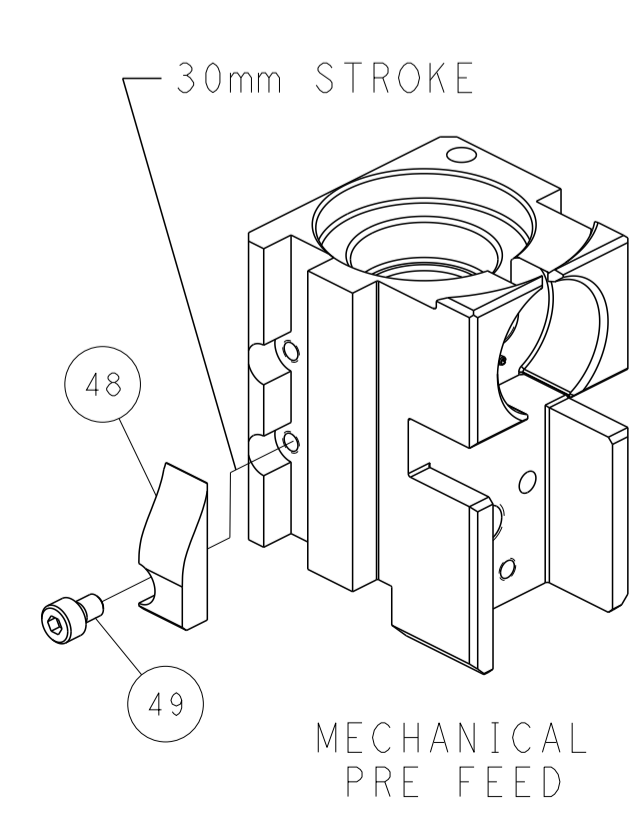
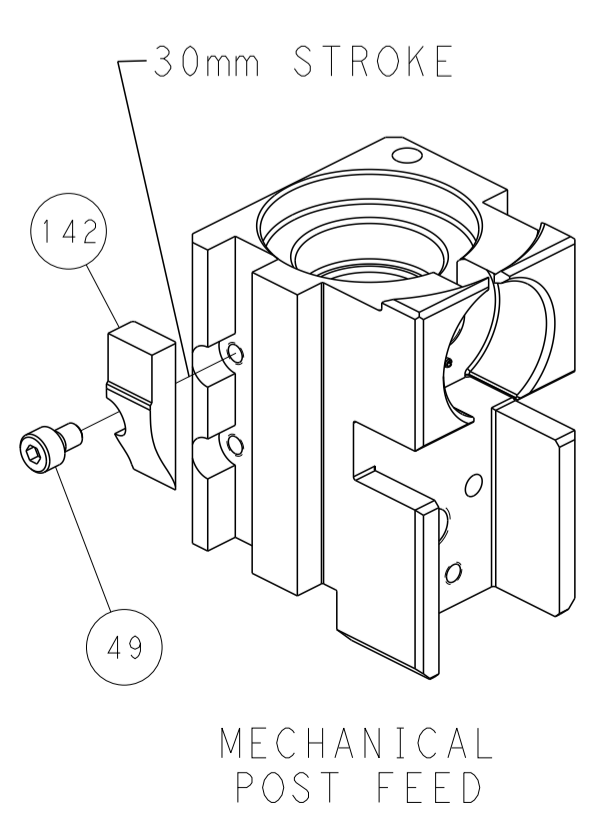

TERMINAL SUPPORT LOCATION

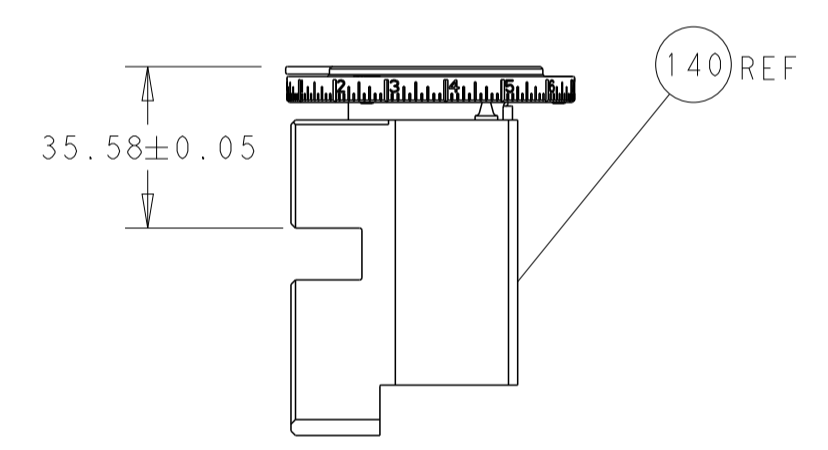

RAM SET-UP

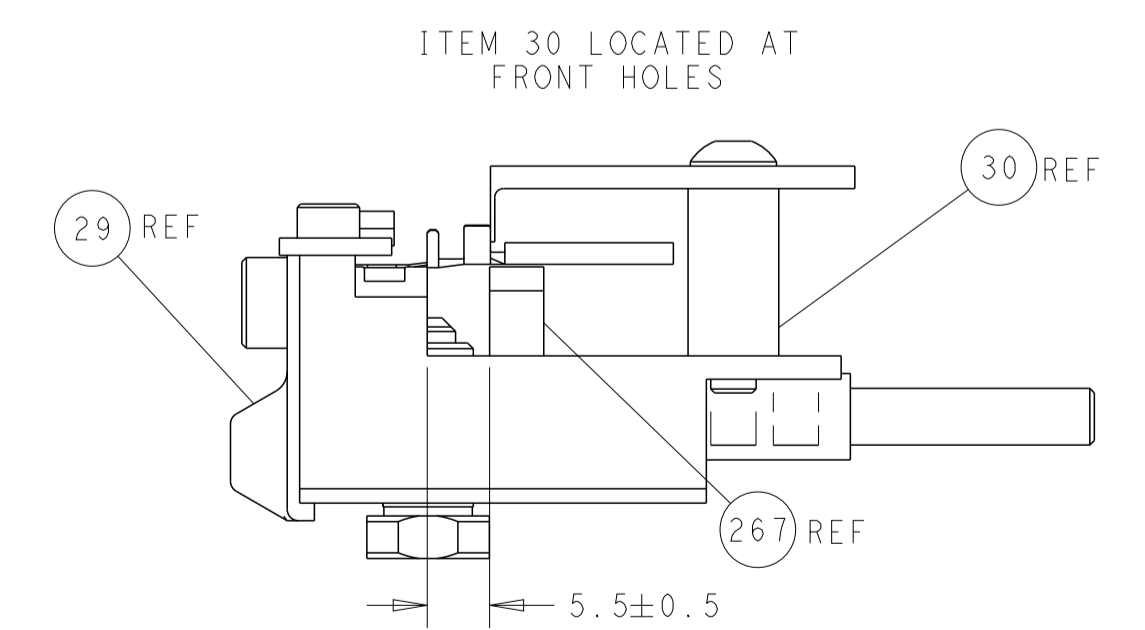

FEED TRACK POSITION GUIDE BY WIRE BARREL

PACIFIC VERSION
 Shown on sheets 3 of 4 & 4 of 4
 (Atlantic version shown on sheets 1 of 4 & 2 of 4)

<small>THIS DRAWING IS UNPUBLISHED. RELEASED FOR PUBLICATION. ALL RIGHTS RESERVED. THIS IS THE PROPERTY OF TYCO ELECTRONICS CORPORATION. IT IS TO BE USED ONLY FOR THE PURPOSES AND IN THE MANNER SPECIFIED BY THE DRAWING. IT IS TO BE RETURNED TO TYCO ELECTRONICS CORPORATION UPON REQUEST.</small>		DWN: R. KNEPPER 17-Oct-13 CHK: G. BAILEY 17-Oct-13 APVD: M. CLIFFORD 17-Oct-13	NAME: TE Connectivity Harrisburg, PA 17105-3608
DIMENSIONS: mm TOLERANCES UNLESS OTHERWISE SPECIFIED: 0 PLC ± 1 PLC ± 2 PLC ± 3 PLC ± 4 PLC ± ANGLES ± FINISH	APPLICATION SPEC: - PRODUCT SPEC: - WEIGHT: - SCALE: 1:2	SIZE: A1 CAGE CODE: 00779 DRAWING NO: C=2266120	RESTRICTED TO: - SHEET: 4 OF 4 REV: K1