

DESCRIPTION	MATERIAL	FINISH
MODULE ASSEMBLY	EPOXY THERMOSET	COLOR: BLACK
GROMMET	FLOURSILICONE 40/50 PER MIL-R-25988	COLOR: NATURAL
CONTACT SOCKET	BERYLLIUM COPPER PER ASTM-B194	GOLD PLATE PER MIL-G-45204
RETAINING CLIP	BERYLLIUM COPPER PER ASTM-B194 OR STAINLESS STEEL PER QQ-S-766	NONE

REVISIONS				
P	LTR	DESCRIPTION	DATE	OWN
D		REV PER ECO 20-001680	2-7-20	CT

TOP BUSSING ARRANGEMENT

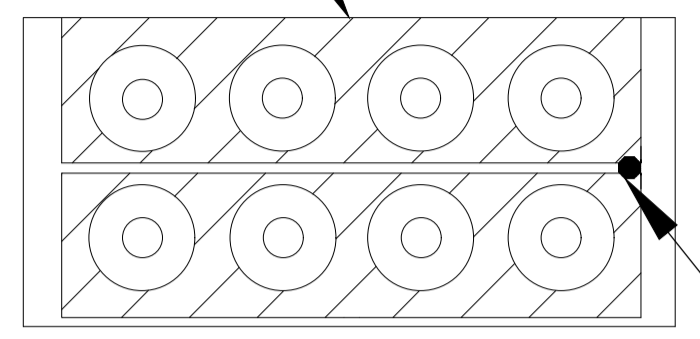

INDEXING INDICATOR

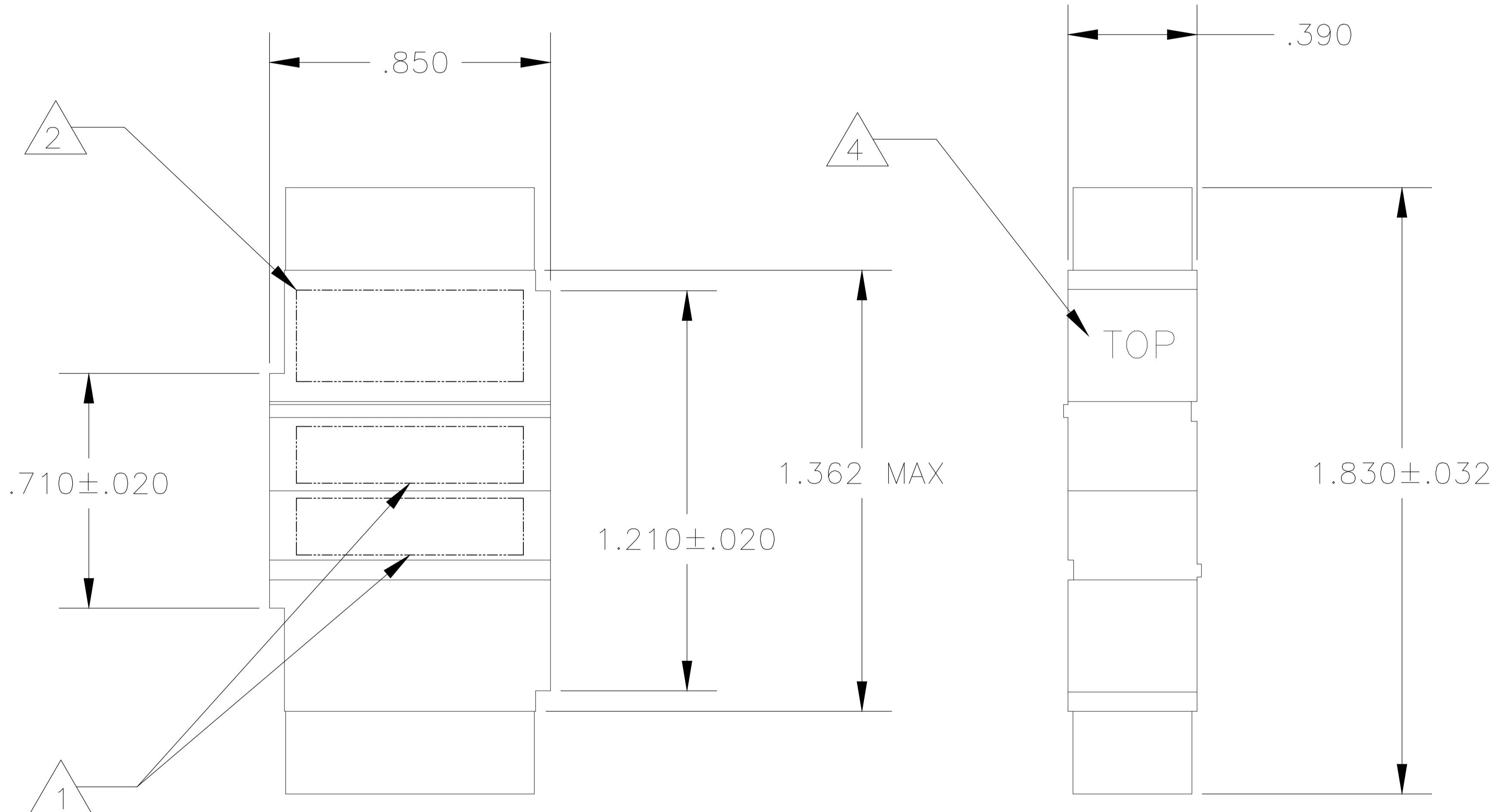

BOTTOM BUSSING ARRANGEMENT

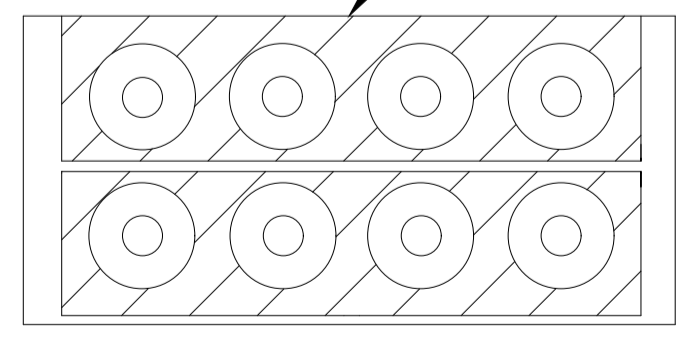

- 1 MODULE ASSEMBLY MARKED WITH "TE", TE PART NO. AND DATE CODE .060 MINIMUM HIGH CHARACTERS ON EITHER SIDE
- 2 MARK MODULE ASSEMBLY WITH CUSTOMER PART NO. 12093B16E13-204 ON EITHER SIDE.
- 3. ROLLS ROYCE QUALITY SPECIFICATION CQC-103 IS INVOKED FOR THIS PART NO.
- 4 MARK WORD "TOP" AT LOCATION SHOWN.

592847-1
PART NO.

THIS DRAWING IS A CONTROLLED DOCUMENT.		DIN N. FRITZ 09-20-93	TE Connectivity	
DIMENSIONS: INCHES		CHK R. RYAN 09-21-93		
TOLERANCES UNLESS OTHERWISE SPECIFIED:		APP'D R. RYAN 09-21-93	NAME MODULE, FEED BACK SIZE 16 ASSEMBLY TJ	
0 PLC ± - 1 PLC ± - 2 PLC ± - 3 PLC ± .005 4 PLC ± - ANGLES ± -		PRODUCT SPEC	RESTRICTED TO	
MATERIAL		APPLICATION SPEC	SIZE A1	CAGE CODE 00779
FINISH		WEIGHT 0.000000	DRAWING NO. 592847	REV D
		CUSTOMER DRAWING	SCALE 2:1	SHEET 1 of 1