

PART NUMBER	REVISION	DESCRIPTION	FEED TYPE
2150254-1	D	FINE CRIMP HEIGHT ADJUST	MECHANICAL
2150254-2	D	FINE CRIMP HEIGHT ADJUST	PNEUMATIC
7-2150254-1	D	MECHANICAL AND CRIMP TOOLING KIT	MECHANICAL
7-2150254-2	D	PNEUMATIC AND CRIMP TOOLING KIT	PNEUMATIC
7-2150254-7	A	CRIMP TOOLING KIT	-

ATLANTIC VERSION TERMINATOR INTERFACE ADAPTER

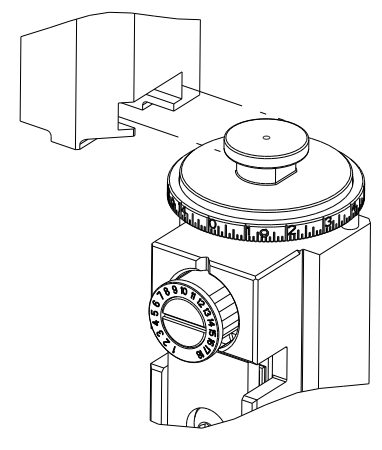

APPLICATOR DATA		
CRIMP	SIZE	TYPE
WIRE	2.29 mm [.090]	F
INSUL	2.54 mm [.100]	O
APPLICATOR INSTRUCTIONS 408-35043		

TERMINAL DATA: TE TERMINAL		TE CRIMP SPECIFICATION	
TERMINAL NAME: RECEPTACLE, FASTIN-FASTON, .250 SERIES			
WIRE STRIP LENGTH		INSULATION DIAMETER RANGE	
5.44-6.07 mm [.214-.239 IN]		Ø1.52-2.54 mm [.060-.100 IN]	
TERMINAL APPLICATION SPECIFICATION	114-2025		
TERMINALS APPLIED			
TE TERMINAL	TE TERMINAL	TE TERMINAL	TE TERMINAL
60413-1			

WIRE SIZE	CRIMP HEIGHT mm [INCH]	CRIMP HEIGHT REFERENCE SETTING
18 AWG	1.22 +/- 0.05 [.048 +/- .002]	7.5
20 AWG	1.12 +/- 0.05 [.044 +/- .002]	9.4
22 AWG	1.07 +/- 0.05 [.042 +/- .002]	10.0

- 1. RECOMMENDED SPARE PARTS
- 2. REFER TO SUPPLIED INSTRUCTION SHEET FOR CLEANING, LUBRICATION AND STORAGE OF APPLICATOR.
- 3. APPLY PART NUMBER 1-23419-5 LOCTITE TO THREADS OF ITEMS 50. APPLY PART NUMBER 2-23419-6 LOCTITE TO THREADS OF ITEM 242.
- 4. CRIMP HEIGHT REFERENCE SETTING WAS THE SETTING USED WHEN THE APPLICATOR WAS QUALIFIED AT THE FACTORY. ADJUSTMENT MAY BE NECESSARY WHEN RUNNING APPLICATOR IN THE FIELD.
- 5. THE RECOMMENDED SET-UP FOR END FEED APPLICATORS IS POST-FEED WITH ITEM 2119653-1. THE APPLICATOR CAN BE CONFIGURED FOR PRE-FEED WITH ITEM 2119652-1 BUT MAY ENCOUNTER PROBLEMS WITH SOME APPLICATIONS. FEED ISSUES OR TERMINAL JAMMING MAY OCCUR IN THE PRE-FEED CONFIGURATION.
- 6. UNLESS SPECIFIED OTHERWISE TORQUE VALUES SHALL BE USED PER DOCUMENT, 101-35000.

**\*WARNING**  
ON INSTALLATION, SET WIRE DISC TO CRIMP HEIGHT REFERENCE SETTING FOR LARGEST WIRE SIZE. CRIMP HEIGHT REFERENCE SETTINGS GREATER THAN THE VALUE SHOWN MAY CAUSE DAMAGE TO THE CRIMP TOOLING, REFER TO THE INSTRUCTION SHEET FOR PROPER SETUP AND ADJUSTMENTS.

ATLANTIC VERSION  
Shown on sheets 1 of 4 & 2 of 4  
(Pacific version shown on sheets 3 of 4 & 4 of 4)

LOC	DIST	REVISIONS					
A	66	P	LTN	DESCRIPTION	DATE	OWN	APVD
		B		ECR-18-014813	18SEP2018	JAH	TE
		B1		ECR-18-016520	17OCT2018	JAH	TE
		C		ECR-20-006590	07MAY2020	MEH	GB
		D		ECR-23-165984	10FEB2023	FZ	TE

-	1	-	1	-	2119641-1	FEED CAM, AIR FEED	248					
-	1	1	1	1	2119082-9	CAM, SNAIL, INSULATION ADJUSTMENT	244					
-	1	1	1	1	2079764-1	WASHER, WAVE SPRING, CREST-TO-CREST	243					
-	1	1	1	1	2119083-1	RETAINER, INSULATION DIAL	242					
-	-	1	-	1	2119580-1	MECHANICAL FEED ASSEMBLY	239					
-	1	-	1	-	2844940-3	AIR FEED MODULE	238					
-	1	1	1	1	1-18028-0	WASHER, FLAT, REG M8	192					
-	1	1	1	1	6-993111-6	PIN, SLOTTED SPRING 3.0 X 14.0	177					
-	1	1	1	1	8-22280-7	SPRING, COMPRESSION	176					
-	1	1	1	1	1752353-2	GUIDE PIN, HOLDDOWN	175					
-	1	1	1	1	1901680-2	GUIDE PIN, HOLDDOWN	174					
-	REF	REF	REF	REF	994970-2	COUNTER, MAGNETIC	164					
-	1	1	1	1	455888-8	SPACER, CRIMPER	82					
-	1	1	1	1	1803607-4	DOCUMENTATION PACKAGE	71					
-	2	2	2	2	2-18032-2	SCR, SET, FLT PNT, M3 X 10.0	70					
-	1	1	1	1	2119740-1	TAG, IDENTIFICATION	67					
-	2	2	2	2	2168078-1	SCREW, DRIVE, RH, RoHS, 2 x .188	66					
-	1	1	1	1	1901681-1	HOLDDOWN, TERMINAL	65					
-	2	2	2	2	2168400-8	SHCS, LOW HEAD, RoHS, M4 X 16	64					
-	1	1	1	1	2168083-2	SCR, SKT HD CAP, RoHS, M4 X 8.0	60					
-	1	1	1	1	5-18022-5	SCR, HEX HD CAP, M4 X 6.0	59					
-	-	1	-	1	2063961-1	FEED FINGER	58					
-	3	3	3	3	2168400-4	SHCS, LOW HEAD, RoHS, M4 X 8	57					
-	2	2	2	2	1-2168083-0	SCR, SKT HD CAP, RoHS, M4 X 10	56					
-	2	2	2	2	5018030-1	NUT, HEX, REG, RoHS, M3	54					
-	2	2	2	2	986965-8	NUT, LOCK, HEX, TORQUE (M4)	53					
-	1	1	1	1	1-5018030-0	NUT, HEX, REG, RoHS, M3.5	52					
-	1	-	1	-	2063961-1	FEED FINGER	51					
-	1	1	1	1	1-1976055-0	STANDOFF, HOLD-DOWN	50					
-	1	2	1	2	18023-9	SCR, SKT HD CAP M4 X 6.0	49					
-	-	1	-	1	2119652-1	FEED CAM, PRE FEED	48					
-	-	1	-	1	2119653-1	FEED CAM, POST FEED	47					
-	1	1	1	1	2119655-5	APPLICATOR BASIC ASSEMBLY, EF	46					
-	1	1	1	1	1803517-1	RAM ASSEMBLY, EF ATLANTIC	44					
-	1	1	1	1	1803602-1	SCR, BHSC, RoHS (M8 X 25)	41					
-	7	7	7	7	1-18028-2	WASHER, FLAT, REG M4	33					
-	2	2	2	2	2168083-9	SCR, SKT HD CAP, RoHS, M4 X 20	31					
-	2	2	2	2	2168083-2	SCR, SKT HD CAP, RoHS, M4 X 8.0	29					
-	1	1	1	1	240639-1	STRIPPER (MACHINING)	27					
-	2	2	2	2	1-2168083-5	SCR, SKT HD CAP, RoHS, M4 X 30	25					
-	1	1	1	1	1752371-6	PLATE, STRIP GUIDE	24					
-	1	1	1	1	240825-1	PLATE, STRIP HOLD DOWN	23					
-	2	2	2	2	2-22281-3	SPRING, COMPRESSION	22					
-	1	1	1	1	1803292-1	DRAG	20					
-	2	2	2	2	1901259-3	GUIDE, LOWER STRIP	18					
-	4	4	4	4	1-2079383-1	SCR, BHSC, RoHS (M6 X 12)	17					
-	1	1	1	1	6-240641-7	SPACER	16					
-	1	1	1	1	1752360-1	SPACER, HOLD-DOWN	13					
-	1	1	1	1	240833-2	PLATE, REAR SHEAR	11					
-	-	-	-	-	-	-	10					
-	1	1	1	1	690482-3	PLATE, FRONT SHEAR	9					
-	1	2	2	1	1-1803000-3	ANVIL, COMBINATION, END FEED	8					
-	1	1	1	1	690474-3	BLADE, SLUG	7					
-	1	1	1	1	2-240641-0	SPACER	5					
-	1	1	1	1	238011-2	BLOCK, CRIMPER SPACER	4					
-	1	2	2	1	1633965-3	CRIMPER, INSULATION O PREMIUM	3					
-	1	1	1	1	455888-7	SPACER, CRIMPER	2					
-	1	2	2	1	4-456406-5	CRIMPER, WIRE PREMIUM	1					
-	77	-	72	-	71	-	2	-	1	PART NO	DESCRIPTION	ITEM NO

DIMENSIONS:		TOLERANCES UNLESS OTHERWISE SPECIFIED:		OWN: X. ZHAO 14MAR2012		TE Connectivity	
mm		0 PLC ±		CHK: T. ELBIN 14MAR2012		Harrisburg, PA 17105-3608	
		1 PLC ±		APVD: S. XI 14MAR2012		NAME: Ocean End Feed Applicator	
		2 PLC ±		PRODUCT SPEC		SIZE: A1	
		3 PLC ±		APPLICATION SPEC		CAGE CODE: 00779	
		4 PLC ±		WEIGHT		DRAWING NO: C=2150254	
		ANGLES		MATERIAL		SCALE: 1:1	
		FINISH		RESTRICTED TO		SHEET 1 OF 4	
				Customer Accessible Production Drawing		REV D	

LOC	DIST	REVISIONS					
		P	LTN	DESCRIPTION	DATE	OWN	APVD
A	66	-	-	SEE SHEET 1	-	-	-

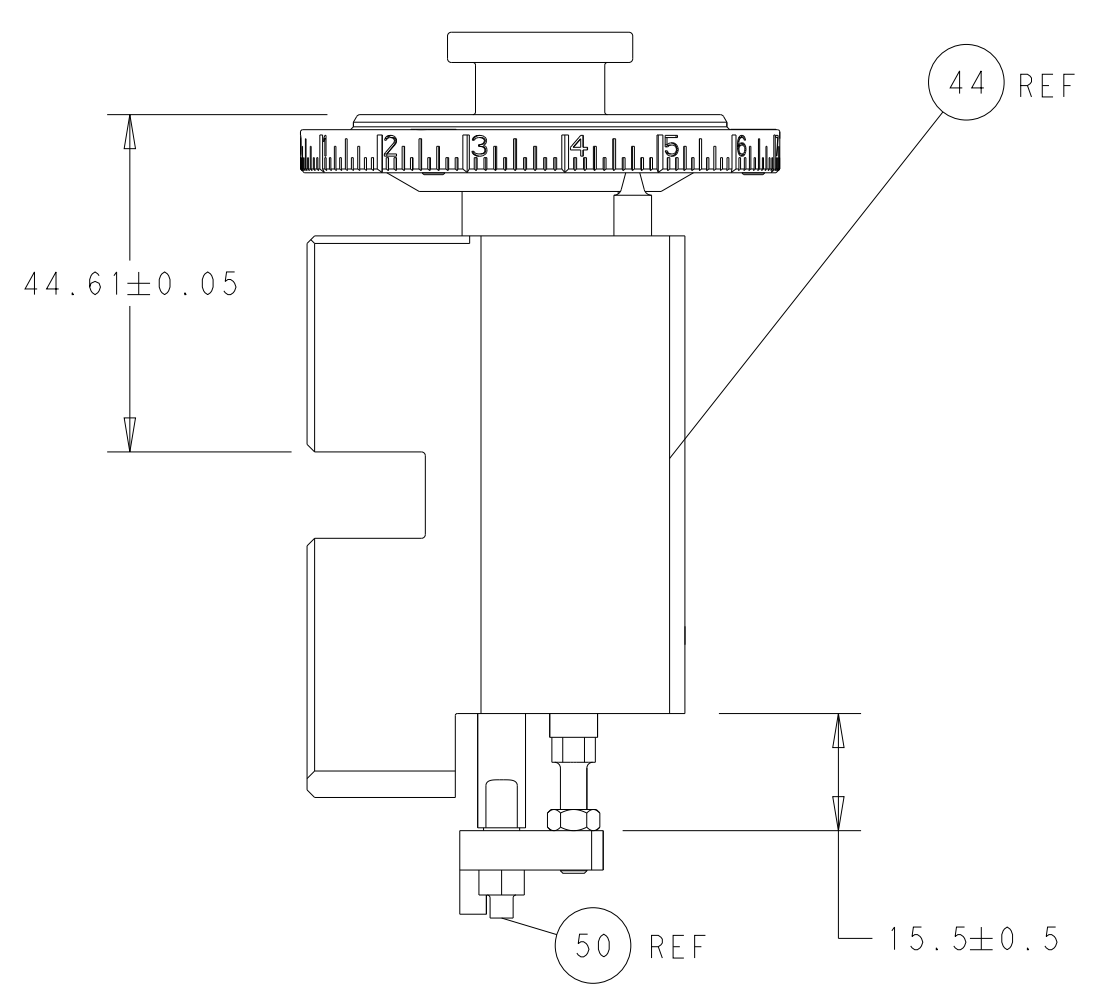

RAM AND HOLDDOWN SET-UP

FEED TYPE  
MECHANICAL

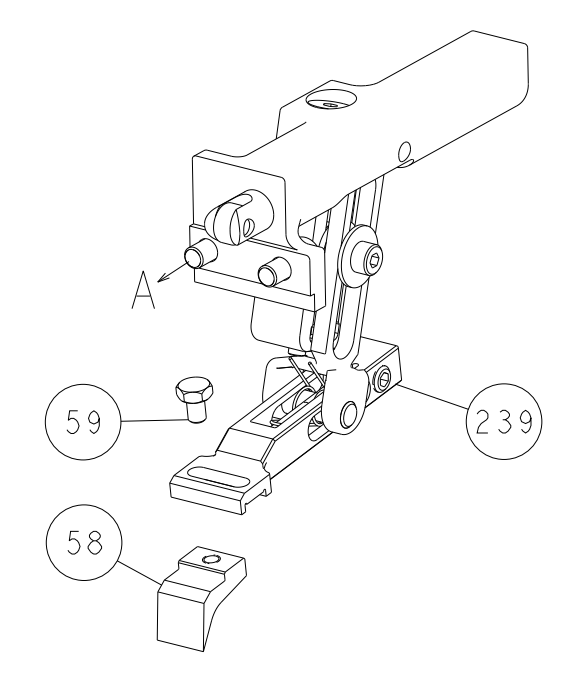

PNEUMATIC

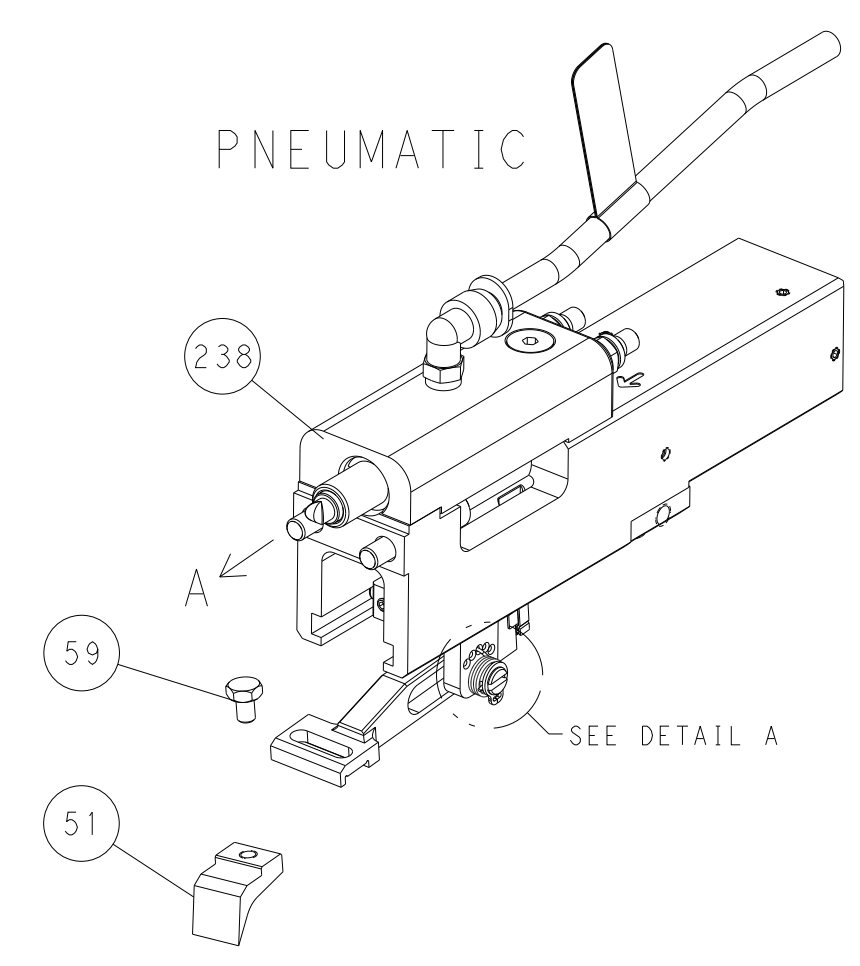

FEED SPRING  
SETTING POSITION

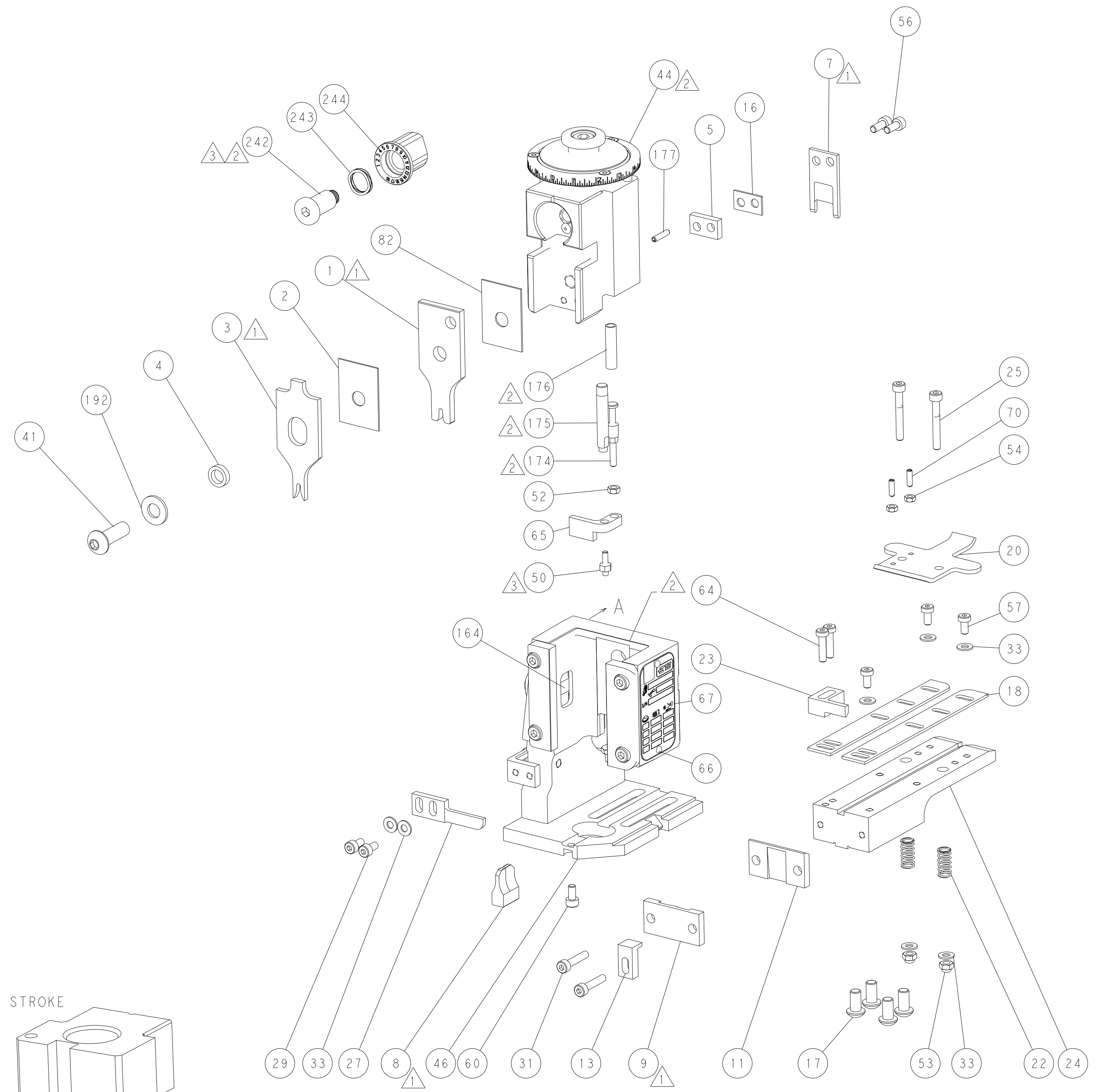
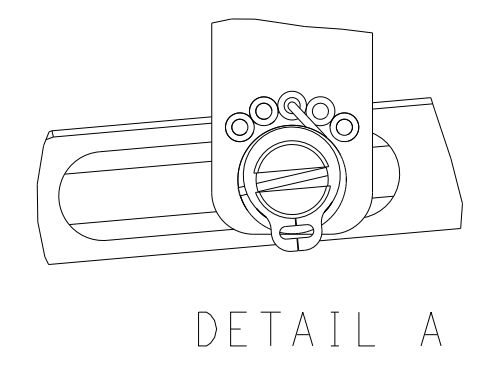

CAM POSITIONS

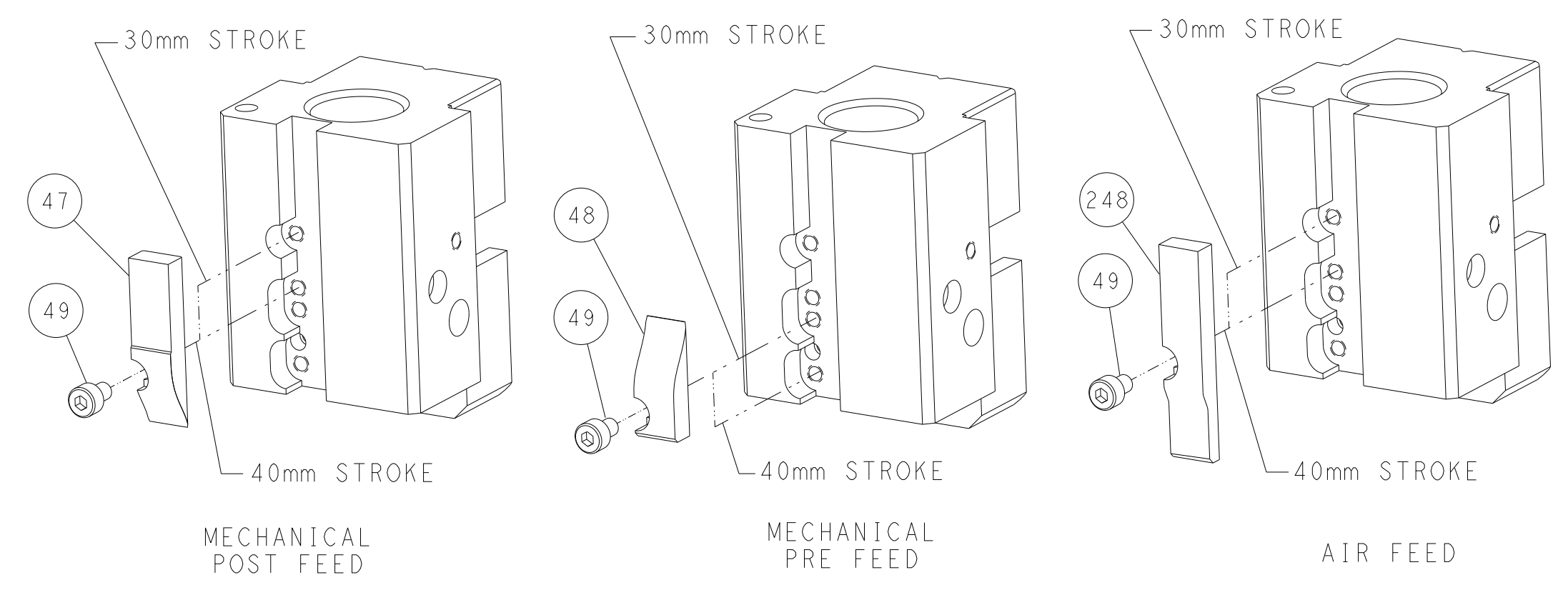

ATLANTIC VERSION  
 Shown on sheets 1 of 4 & 2 of 4  
 (Pacific version shown on sheets 3 of 4 & 4 of 4)

DIMENSIONS:		TOLERANCES UNLESS OTHERWISE SPECIFIED:		DWG X_ZHAO 14MAR2012		TE Connectivity	
mm		0 PLC ±		CHK T_ELBIN 14MAR2012		Harrisburg, PA 17105-3608	
Ø		1 PLC ±		APVD S_XI 14MAR2012		NAME	
H		2 PLC ±		PRODUCT SPEC		Ocean End Feed	
D		3 PLC ±		APPLICATION SPEC		Applicator	
R		4 PLC ±		SIZE CAGE CODE DRAWING NO		RESTRICTED TO	
A		5 PLC ±		A1 00779 C=2150254		Customer Accessible Production Drawing	
F		6 PLC ±		SCALE 1:1		SHEET 2 of 4	
S		7 PLC ±		REV D			
T		8 PLC ±					
V		9 PLC ±					
W		10 PLC ±					
X		11 PLC ±					
Y		12 PLC ±					
Z		13 PLC ±					
AA		14 PLC ±					
AB		15 PLC ±					
AC		16 PLC ±					
AD		17 PLC ±					
AE		18 PLC ±					
AF		19 PLC ±					
AG		20 PLC ±					
AH		21 PLC ±					
AI		22 PLC ±					
AJ		23 PLC ±					
AK		24 PLC ±					
AL		25 PLC ±					
AM		26 PLC ±					
AN		27 PLC ±					
AO		28 PLC ±					
AP		29 PLC ±					
AQ		30 PLC ±					
AR		31 PLC ±					
AS		32 PLC ±					
AT		33 PLC ±					
AU		34 PLC ±					
AV		35 PLC ±					
AW		36 PLC ±					
AX		37 PLC ±					
AY		38 PLC ±					
AZ		39 PLC ±					
BA		40 PLC ±					
BB		41 PLC ±					
BC		42 PLC ±					
BD		43 PLC ±					
BE		44 PLC ±					
BF		45 PLC ±					
BG		46 PLC ±					
BH		47 PLC ±					
BI		48 PLC ±					
BJ		49 PLC ±					
BK		50 PLC ±					
BL		51 PLC ±					
BM		52 PLC ±					
BN		53 PLC ±					
BO		54 PLC ±					
BP		55 PLC ±					
BQ		56 PLC ±					
BR		57 PLC ±					
BS		58 PLC ±					
BT		59 PLC ±					
BU		60 PLC ±					
BV		61 PLC ±					
BW		62 PLC ±					
BX		63 PLC ±					
BY		64 PLC ±					
BZ		65 PLC ±					
CA		66 PLC ±					
CB		67 PLC ±					
CC		68 PLC ±					
CD		69 PLC ±					
CE		70 PLC ±					
CF		71 PLC ±					
CG		72 PLC ±					
CH		73 PLC ±					
CI		74 PLC ±					
CJ		75 PLC ±					
CK		76 PLC ±					
CL		77 PLC ±					
CM		78 PLC ±					
CN		79 PLC ±					
CO		80 PLC ±					
CP		81 PLC ±					
CQ		82 PLC ±					
CR		83 PLC ±					
CS		84 PLC ±					
CT		85 PLC ±					
CU		86 PLC ±					
CV		87 PLC ±					
CW		88 PLC ±					
CX		89 PLC ±					
CY		90 PLC ±					
CZ		91 PLC ±					
DA		92 PLC ±					
DB		93 PLC ±					
DC		94 PLC ±					
DD		95 PLC ±					
DE		96 PLC ±					
DF		97 PLC ±					
DG		98 PLC ±					
DH		99 PLC ±					
DI		100 PLC ±					

PART NUMBER	REVISION	DESCRIPTION	FEED TYPE
2-2150254-1	D	FINE CRIMP HEIGHT ADJUST	MECHANICAL
2-2150254-2	D	FINE CRIMP HEIGHT ADJUST	PNEUMATIC
7-2150254-7	A	CRIMP TOOLING KIT	-

PACIFIC VERSION TERMINATOR  
INTERFACE ADAPTER

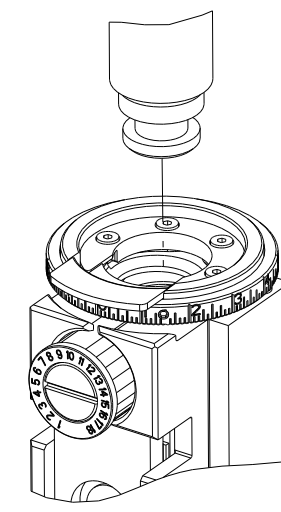

APPLICATOR DATA		
CRIMP	SIZE	TYPE
WIRE	2.29 mm (.090)	F
INSUL	2.54 mm (.100)	Ø
APPLICATOR INSTRUCTIONS 408-35043		

TERMINAL DATA: TE TERMINAL		TE CRIMP SPECIFICATION	
TERMINAL NAME: RECEPTACLE, FASTIN-FASTON, .250 SERIES			
WIRE STRIP LENGTH 5.44-6.07 mm (.214-.239 IN)		INSULATION DIAMETER RANGE Ø1.52-2.54 mm (.060-.100 IN)	
TERMINAL APPLICATION SPECIFICATION 114-2025			
TERMINALS APPLIED			
TE TERMINAL	TE TERMINAL	TE TERMINAL	TE TERMINAL
60413-1			

WIRE SIZE	CRIMP HEIGHT mm [INCH]	CRIMP HEIGHT REFERENCE SETTING
18 AWG	1.22+/-0.05 [.048+/-0.002]	7.5
20 AWG	1.12+/-0.05 [.044+/-0.002]	9.4
22 AWG	1.07+/-0.05 [.042+/-0.002]	10.0

- 1 RECOMMENDED SPARE PARTS
- 2 REFER TO SUPPLIED INSTRUCTION SHEET FOR CLEANING, LUBRICATION AND STORAGE OF APPLICATOR.
- 3 APPLY PART NUMBER 1-23419-5 LOCTITE TO THREADS OF ITEMS 50. APPLY PART NUMBER 2-23419-6 LOCTITE TO THREADS OF ITEM 242.
- 4 CRIMP HEIGHT REFERENCE SETTING WAS THE SETTING USED WHEN THE APPLICATOR WAS QUALIFIED AT THE FACTORY. ADJUSTMENT MAY BE NECESSARY WHEN RUNNING APPLICATOR IN THE FIELD.
- 5 THE RECOMMENDED SET-UP FOR END FEED APPLICATORS IS POST-FEED WITH ITEM 2119653-1. THE APPLICATOR CAN BE CONFIGURED FOR PRE-FEED WITH ITEM 2119652-1 BUT MAY ENCOUNTER PROBLEMS WITH SOME APPLICATIONS. FEED ISSUES OR TERMINAL JAMMING MAY OCCUR IN THE PRE-FEED CONFIGURATION.
- 6. UNLESS SPECIFIED OTHERWISE TORQUE VALUES SHALL BE USED PER DOCUMENT, 101-35000.

**\*WARNING**  
ON INSTALLATION, SET WIRE DISC TO CRIMP HEIGHT REFERENCE SETTING FOR LARGEST WIRE SIZE. CRIMP HEIGHT REFERENCE SETTINGS GREATER THAN THE VALUE SHOWN MAY CAUSE DAMAGE TO THE CRIMP TOOLING, REFER TO THE INSTRUCTION SHEET FOR PROPER SETUP AND ADJUSTMENTS.

PACIFIC VERSION  
Shown on sheets 3 of 4 & 4 of 4  
(Atlantic version shown on sheets 1 of 4 & 2 of 4)

LOC	DIST	REVISIONS					
A	66	P	LTN	DESCRIPTION	DATE	OWN	APVD
-	-	-	-	SEE SHEET 1	-	-	-

-	1	1	2119082-9	CAM, SNAIL, INSULATION ADJUSTMENT	244
-	1	1	2079764-1	WASHER, WAVE SPRING, CREST-TO-CREST	243
-	1	1	2119083-1	RETAINER, INSULATION DIAL	242
-	-	1	2119580-1	MECHANICAL FEED ASSEMBLY	239
-	1	-	2844940-3	AIR FEED MODULE	238
-	1	1	1-18028-0	WASHER, FLAT, REG M8	192
-	4	4	2079383-9	SCR, BHSC, RoHS (M6 X 20)	186
-	1	1	6-993111-6	PIN, SLOTTED SPRING 3.0 X 14.0	177
-	1	1	8-22280-7	SPRING, COMPRESSION	176
-	1	1	1752353-2	GUIDE PIN, HOLDDOWN	175
-	1	1	1901680-2	GUIDE PIN, HOLDDOWN	174
-	REF	REF	994970-2	COUNTER, MAGNETIC	164
-	1	-	2119641-2	FEED CAM, AIR FEED	152
-	1	1	2168083-8	SCR, SKT HD CAP, RoHS, M4 X 16	144
-	-	1	2119653-2	FEED CAM, POST FEED	142
-	1	1	2119655-6	APPLICATOR BASIC ASSEMBLY, EF	141
-	1	1	1803518-1	RAM ASSEMBLY, EF PACIFIC	140
-	1	1	455888-8	SPACER, CRIMPER	82
-	1	1	1803607-4	DOCUMENTATION PACKAGE	71
-	2	2	2-18032-2	SCR, SET, FLT PNT, M3 X 10.0	70
-	1	1	2119740-1	TAG, IDENTIFICATION	67
-	2	2	2168078-1	SCREW, DRIVE, RH, RoHS, 2 x .188	66
-	1	1	1901681-1	HOLDDOWN, TERMINAL	65
-	2	2	2168400-8	SHCS, LOW HEAD, RoHS, M4 X 16	64
-	1	1	5-18022-5	SCR, HEX HD CAP, M4 X 6.0	59
-	-	1	2063961-1	FEED FINGER	58
-	3	3	2168400-4	SHCS, LOW HEAD, RoHS, M4 X 8	57
-	2	2	1-2168083-0	SCR, SKT HD CAP, RoHS, M4 X 10	56
-	2	2	5018030-1	NUT, HEX, REG, RoHS, M3	54
-	2	2	986965-8	NUT, LOCK, HEX, TORQUE (M4)	53
-	1	1	1-5018030-0	NUT, HEX, REG, RoHS, M3.5	52
-	1	-	2063961-1	FEED FINGER	51
-	1	1	1-1976055-0	STANDOFF, HOLD-DOWN	50
-	1	2	18023-9	SCR, SKT HD CAP M4 X 6.0	49
-	-	1	2119652-1	FEED CAM, PRE FEED	48
-	1	1	1803602-1	SCR, BHSC, RoHS (M8 X 25)	41
-	7	7	1-18028-2	WASHER, FLAT, REG M4	33
-	2	2	2168083-9	SCR, SKT HD CAP, RoHS, M4 X 20	31
-	2	2	2168083-2	SCR, SKT HD CAP, RoHS, M4 X 8.0	29
-	1	1	240639-1	STRIPPER (MACHINING)	27
-	2	2	1-2168083-5	SCR, SKT HD CAP, RoHS, M4 X 30	25
-	1	1	1752371-6	PLATE, STRIP GUIDE	24
-	1	1	240825-1	PLATE, STRIP HOLD DOWN	23
-	2	2	2-22281-3	SPRING, COMPRESSION	22
-	1	1	1803292-1	DRAG	20
-	2	2	1901259-3	GUIDE, LOWER STRIP	18
-	1	1	6-240641-7	SPACER	16
-	1	1	1752360-1	SPACER, HOLD-DOWN	13
-	1	1	240833-2	PLATE, REAR SHEAR	11
-	-	-	-	-	10
-	1	1	690482-3	PLATE, FRONT SHEAR	9
-	1	1	1-1803000-3	ANVIL, COMBINATION, END FEED	8
-	1	1	690474-3	BLADE, SLUG	7
-	1	1	2-240641-0	SPACER	5
-	1	1	238011-2	BLOCK, CRIMPER SPACER	4
-	1	1	1633965-3	CRIMPER, INSULATION O PREMIUM	3
-	1	1	455888-7	SPACER, CRIMPER	2
-	1	1	4-456406-5	CRIMPER, WIRE PREMIUM	1
-	77	22	21	PART NO	ITEM NO

DIMENSIONS:		TOLERANCES UNLESS OTHERWISE SPECIFIED:		DRAWING NO	
mm	0 PLC ±	1 PLC ±	2 PLC ±	3 PLC ±	4 PLC ±
	ANGLES	FINISH			
MATERIAL		WEIGHT		SCALE	REV



Ocean End Feed  
Applicator

Customer Accessible Production Drawing  
SCALE 1:1 SHEET 3 OF 4 REV D

