

# Customer Information Sheet

DRAWING No.: M20-11800XX

SHEET 2 OF 2

IF IN DOUBT - ASK

©

NOT TO SCALE

THIRD ANGLE PROJECTION

ALL DIMENSIONS IN mm

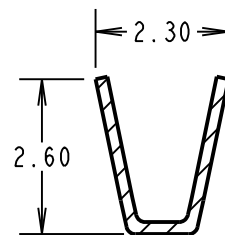
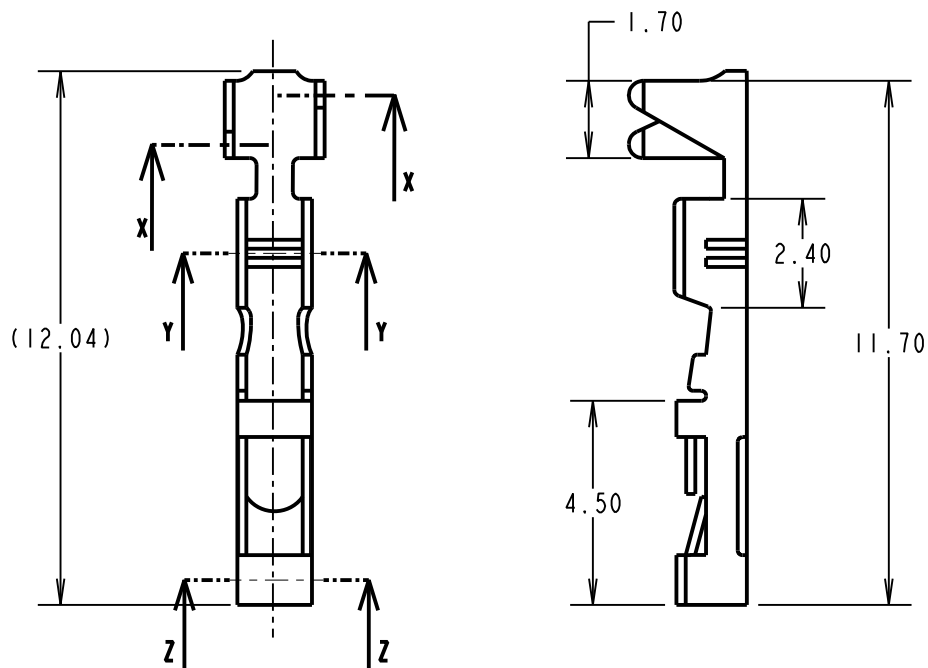

SECTION X-X

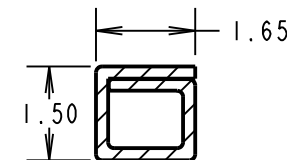

SECTION Z-Z

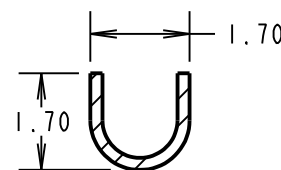

SECTION Y-Y

ORDER CODE:  
**M20-11800XX**  
 FINISH: \_\_\_\_\_  
 42 = GOLD + 100% TIN  
 46 = 100% TIN OVER NICKEL

- NOTES:
1. TO BE USED WITH CRIMP MOULDINGS M20-106XX00 AND M20-107XX00. SEE MOULDING DRAWING FOR COMPONENT SPECIFICATION.
  2. CONTACTS SUPPLIED LOOSE IN QUANTITIES OF 100.
  3. FOR COMPLETE SPECIFICATION, SEE COMPONENT SPECIFICATION C001XX (LATEST ISSUE).
  4. ACCEPTS WIRE RANGE 22-30 AWG.
  5. DIAMETER OF WIRE INSULATION =  $\varnothing$ 1.60-0.90mm.
  6. TO BE USED WITH HAND TOOL Z20-320, SEE INSTRUCTION SHEET IS-15 FOR DETAILS.
  7. STRIP WIRE BY 3.0 - 4.0mm FOR CRIMPING.
  8. RECOMMENDED CONDUCTOR CRIMP HEIGHTS:  
 FOR 26 - 30 AWG = 0.69 - 0.75mm  
 FOR 22 - 24 AWG = 0.83 - 0.89mm

SPECIFICATIONS:  
 MATERIAL = BRASS  
 FINISH:  
 42 = GOLD + 100% TIN  
 46 = 100% TIN OVER NICKEL  
 MECHANICAL:  
 WITHDRAWAL FORCE = 1.5-0.8N

SB	13	30.07.12	11756
NAME	ISS.	DATE	C/NOTE
APPROVED: S.BENNETT			
CHECKED: S.FLOWER			
DRAWN: W.J.BOURNE			
CUSTOMER REF.:			
ASSEMBLY DRG:			

## HARWIN

www.harwin.com  
 technical@harwin.com

THIS DRAWING AND ANY INFORMATION OR DESCRIPTIVE MATTER SET OUT HEREON ARE CONFIDENTIAL AND COPYRIGHT PROPERTY OF THE HARWIN GROUP AND MUST NOT BE DISCLOSED, LOANED, COPIED OR USED FOR MANUFACTURING, TENDERING OR FOR ANY OTHER PURPOSE WITHOUT THEIR WRITTEN PERMISSION.

TOLERANCES  
 X. =  $\pm$ 1mm  
 X.X =  $\pm$ 0.50mm  
 X.XX =  $\pm$ 0.10mm  
 X.XXX =  $\pm$ 0.01mm  
 ANGLES =  $\pm$ 5°  
 UNLESS STATED

MATERIAL:  
 SEE ABOVE  
 FINISH: SEE ABOVE  
 S/AREA: mm<sup>2</sup>

TITLE:  
 2.54mm FEMALE CRIMP TERMINAL (LOOSE)  
 DRAWING NUMBER:  
**M20-11800XX**

SHT  
 2 OF 2