

Axial, Molded, X7R Dielectric, 50 – 100 VDC (Commercial Grade)

Overview

KEMET's epoxy molded axial through-hole ceramic capacitors in X7R dielectric feature a 125°C maximum operating temperature. The Electronics Industries Alliance (EIA) characterizes X7R dielectric as a Class II "temperature stable" material. Components of this classification are fixed, ceramic dielectric capacitors suited for bypass and decoupling applications or for frequency

discriminating circuits where Q and stability of capacitance characteristics are not critical. X7R exhibits a predictable change in capacitance with respect to time and voltage and boasts a minimal change in capacitance with reference to ambient temperature. Capacitance change is limited to $\pm 15\%$ from -55°C to $+125^{\circ}\text{C}$. These devices meet the flame test requirements outlined in UL Standard 94 V-0.

Benefits

- Axial through-hole form factor
- Molded case
- -55°C to $+125^{\circ}\text{C}$ operating temperature range
- X7R temperature stable dielectric
- DC voltage ratings of 50 V and 100 V
- Capacitance offerings ranging from 10 pF to 3.3 μF
- Available capacitance tolerances of $\pm 10\%$ and $\pm 20\%$
- Non-polar device, minimizing installation concerns
- SnPb-plated lead finish (60/40)
- Encapsulation meets flammability standard UL 94 V-0

Applications

Typical applications include decoupling, bypass, filtering and transient voltage suppression.



Ordering Information

C	114	C	472	M	1	R	5	C	A	7200
Ceramic	Style /Size	Specification/ Series	Capacitance Code (pF)	Capacitance Tolerance ¹	Rated Voltage (VDC)	Dielectric	Design	Lead Finish ²	Failure Rate	Packaging/ Grade (C-Spec)
	114 124 192 202 222	C = Standard	Two significant digits and number of zeros	K = $\pm 10\%$ M = $\pm 20\%$	5 = 50 1 = 100	R = X7R	5 = Multilayer	C = SnPb (60/40)	A = N/A	Blank = Bulk 7200 = 12" Reel 7293 = Ammo Pack

¹ Additional capacitance tolerance offerings may be available. Contact KEMET for details.

² Lead materials:

Standard: 60% tin (Sn)/40% lead (Pb) finish with 100% copper core ("C" designation).

Alternative lead materials and finishes may be available. Contact KEMET for details.

Dimensions – Inches (Millimeters)

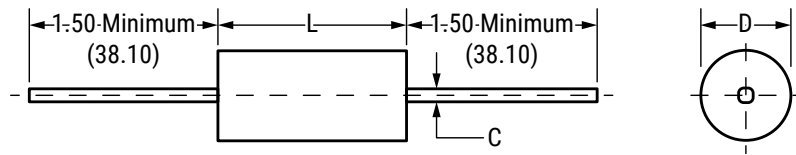

Series	Style/Size	L Length Maximum	D Diameter Maximum	LD Lead Diameter	LL Lead Length Minimum
C1XX	114	0.160±0.010 (4.06±0.25)	0.090±0.010 (2.29±0.25)	0.020+0.0/-0.003 (0.51+0.0/-0.08)	1.50 (38.10)
	124	0.250±0.010 (6.35±0.25)	0.090±0.010 (2.29±0.25)		
	192	0.390±0.010 (9.91±0.25)	0.140±0.010 (3.56±0.25)		
C2XX	202	0.500±0.020 (12.70±0.51)	0.250±0.015 (6.35±0.38)	0.025+0.004/-0.001 (0.64+0.10/-0.025)	
	222	0.690±0.030 (17.53±0.76)	0.350±0.020 (8.89±0.51)		

Application Notes

These devices are not recommended for use in overmold applications and/or processes.

Qualification/Certification

Commercial Grade products are subject to internal qualification. Details regarding test methods and conditions are referenced in Table 2, Performance & Reliability.

Environmental Compliance

These devices do not meet RoHS criteria due to the concentration of Pb containment in the lead finish.

Electrical Parameters/Characteristics

Item	Parameters/Characteristics
Operating Temperature Range	-55°C to +125°C
Capacitance Change with Reference to +25°C and 0 VDC Applied (TCC)	±15%
Aging Rate (Maximum % Cap Loss/Decade Hour)	3.0%
Dielectric Withstanding Voltage	250% of rated voltage (5±1 seconds and charge/discharge not exceeding 50 mA)
Dissipation Factor (DF) Maximum Limit at 25°C	3.5%(25 V) and 2.5%(50 V to 250 V)
Insulation Resistance (IR) Limit at 25°C	1,000 megohm microfarads or 100 GΩ (Rated voltage applied for 120±5 seconds at 25°C)

Regarding aging rate: Capacitance measurements (including tolerance) are indexed to a referee time of 1,000 hours.

To obtain IR limit, divide MΩ-μF value by the capacitance and compare to GΩ limit. Select the lower of the two limits.

Capacitance and dissipation factor (DF) measured under the following conditions:

1 kHz ±50 Hz and $1.0 \pm 0.2 V_{rms}$ if capacitance ≤ 10 μF

120 Hz ±10 Hz and $0.5 \pm 0.1 V_{rms}$ if capacitance > 10 μF

Note: When measuring capacitance it is important to ensure the set voltage level is held constant. The HP4284 and Agilent E4980 have a feature known as Automatic Level Control (ALC). The ALC feature should be switched to "ON."

Post Environmental Limits

High Temperature Life, Biased Humidity, Moisture Resistance				
Dielectric	Rated DC Voltage	Capacitance Value	DF (%)	Capacitance Shift
X7R	> 25	All	3.0	±20%
	16/25		5.0	
	< 16		7.5	

Table 1A – C114 Style/Size (0.090" Diameter x 0.160" L), Capacitance Range Waterfall

C114 Style/Size (0.090" Diameter x 0.160" L)				
Rated Voltage (VDC)		50	100	200
Voltage Code		5	1	2
Capacitance	Capacitance Tolerance	Capacitance Code (Available Capacitance)		
10pF	K = ±10% M = ±20%	100	100	
12pF		120	120	
15pF		150	150	
18pF		180	180	
22pF		220	220	
27pF		270	270	
33pF		330	330	
39pF		390	390	
47pF		470	470	
56pF		560	560	
68pF		680	680	
82pF		820	820	
100pF		101	101	
120pF		121	121	
150pF		151	151	
180pF		181	181	
220pF		221	221	
270pF		271	271	
330pF		331	331	
390pF		391	391	
470pF		471	471	
560pF		561	561	
680pF		681	681	
820pF		821	821	
1000pF		102	102	
1200pF		122	122	
1500pF		152	152	
1800pF		182	182	
2200pF		222	222	
2700pF		272	272	
3300pF		332	332	
3900pF		392	392	
4700pF		472	472	
5600pF	562			
6800pF	682			
8200pF	822			
0.01µF	103			
Rated Voltage (VDC)		50	100	200
Voltage Code		5	1	2

Table 1B – C124 Style/Size (0.090" Diameter x 0.250" L), Capacitance Range Waterfall

C124 Style/Size (0.090" Diameter x 0.250" L)					
Rated Voltage (VDC)		50	100	200	
Voltage Code		5	1	2	
Capacitance	Capacitance Tolerance	Capacitance Code (Available Capacitance)			
5600pF	K = ±10% M = ±20%	562	562		
6800pF		682	682		
8200pF		822	822		
0.01µF		103	103		
0.012µF		123			
0.015µF		153			
0.018µF		183			
0.022µF		223			
0.027µF		273			
0.033µF		333			
0.039µF		393			
0.047µF		473			
Rated Voltage (VDC)		50	100	200	
Voltage Code		5	1	2	

Table 1C – C192 Style/Size (0.140" Diameter x 0.390" L), Capacitance Range Waterfall

C192 Style/Size (0.140" Diameter x 0.390" L)					
Rated Voltage (VDC)		50	100	200	
Voltage Code		5	1	2	
Capacitance	Capacitance Tolerance	Capacitance Code (Available Capacitance)			
0.012µF	K = ±10% M = ±20%	123	123		
0.015µF		153	153		
0.018µF		183	183		
0.022µF		223	223		
0.027µF		273	273		
0.033µF		333	333		
0.039µF		393	393		
0.047µF		473	473		
0.056µF		563	563		
0.068µF		683	683		
0.082µF		823	823		
0.1µF		104	104		
0.12µF		124			
0.15µF		154			
0.18µF		184			
0.22µF		224			
0.27µF		274			
Rated Voltage (VDC)		50	100	200	
Voltage Code		5	1	2	

Table 1D – C202 Style/Size (0.250" Diameter x 0.500" L), Capacitance Range Waterfall

C202 Style/Size (0.250" Diameter x 0.500" L)				
Rated Voltage (VDC)		50	100	200
Voltage Code		5	1	2
Capacitance	Capacitance Tolerance	Capacitance Code (Available Capacitance)		
0.056µF	K = ±10% M = ±20%	563	563	
0.068µF		683	683	
0.082µF		823	823	
0.1µF		104	104	
0.12µF		124	124	
0.15µF		154	154	
0.18µF		184	184	
0.22µF		224	224	
0.27µF		274	274	
0.33µF		334	334	
0.47µF		474		
0.68µF		684		
1.0µF		105		
Rated Voltage (VDC)		50	100	200
Voltage Code		5	1	2

Table 1E – C222 Style/Size (0.350" Diameter x 0.690" L), Capacitance Range Waterfall

C222 Style/Size (0.350" Diameter x 0.690" L)				
Rated Voltage (VDC)		50	100	200
Voltage Code		5	1	2
Capacitance	Capacitance Tolerance	Capacitance Code (Available Capacitance)		
0.47µF	K = ±10% M = ±20%	474	474	
0.68µF		684	684	
1.0µF		105	105	
2.2µF		225		
3.3µF		335		
Rated Voltage (VDC)		50	100	200
Voltage Code		5	1	2

Soldering Process

Recommended Soldering Technique:

- Solder Wave
- Hand Soldering (Manual)

Recommended Soldering Profile:

- Optimum Wave Solder Profile



- Hand Soldering (Manual)

Manual Solder Profile with Pre-heating

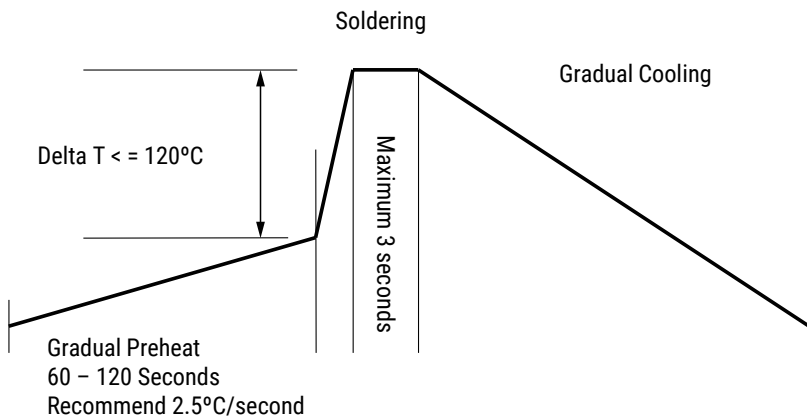

KEMET recommends following the guidelines and techniques outlined in technical bulletins F2103 and F9207.

Table 2 – Performance & Reliability: Test Methods and Conditions

Stress	Reference	Test or Inspection Method
Solderability	J-STD-002	Magnification 50 X. Conditions:
		a) Method B, 4 hours at 155°C, dry heat at 235°C
		b) Method B at 215°C category 3
		c) Method D, category 3 at 260°C
Temperature Cycling	JESD22 Method JA-104	1,000 cycles (-55°C to +125°C), Measurement at 24 hours. +/-2 hours after test conclusion.
Biased Humidity	MIL-STD-202 Method 103	Load Humidity: 1,000 hours 85°C/85% RH and Rated Voltage. Add 100 K ohm resistor. Measurement at 24 hours. +/-2 hours after test conclusion.
		Low Volt Humidity: 1,000 hours 85°C/85% RH and 1.5 V. Add 100 K ohm resistor. Measurement at 24 hours. +/-2 hours after test conclusion.
Moisture Resistance	MIL-STD-202 Method 106	t = 24 hours/cycle. Steps 7a and 7b not required. Unpowered. Measurement at 24 hours. +/-2 hours after test conclusion.
Thermal Shock	MIL-STD-202 Method 107	-55°C/+125°C. Note: Number of cycles required – 300. Maximum transfer time – 20 seconds. Dwell time – 15 minutes. Air – Air.
High Temperature Life	MIL-STD-202 Method 108/EIA-198	1,000 hours at 125°C (85°C for X5R, Z5U and Y5V) with 2 X rated voltage applied.
Storage Life	MIL-STD-202 Method 108	150°C, 0 VDC, for 1,000 hours.
Vibration	MIL-STD-202 Method 204	5 g for 20 minutes, 12 cycles each of 3 orientations. Note: Use 8"X5" PCB .031" thick 7 secure points on one long side and 2 secure points at corners of opposite sides. Parts mounted within 2" from any secure point. Test from 10–2,000 Hz.
Resistance to Soldering Heat	MIL-STD-202 Method 210	Condition B. No pre-heat of samples. Note: single wave solder - procedure 2.
Terminal Strength	MIL-STD-202 Method 211	Conditions A (2.3kg or 5 lbs)
Mechanical Shock	MIL-STD-202 Method 213	Figure 1 of Method 213, Condition F.
Resistance to Solvents	MIL-STD-202 Method 215	Add aqueous wash chemical, OKEM Clean or equivalent.

Storage & Handling

Ceramic chip capacitors should be stored in normal working environments. While the chips themselves are quite robust in other environments, solderability will be degraded by exposure to high temperatures, high humidity, corrosive atmospheres, and long term storage. In addition, packaging materials will be degraded by high temperature-reels may soften or warp, and tape peel force may increase. KEMET recommends that maximum storage temperature not exceed 40°C, and maximum storage humidity not exceed 70% relative humidity. Temperature fluctuations should be minimized to avoid condensation on the parts, and atmospheres should be free of chlorine and sulfur bearing compounds. For optimized solderability, chip stock should be used promptly, preferably within 1.5 years of receipt.

Packaging Details

Lead Spacing	Component Pitch (P1)
0.100 (2.54)	5.08
0.200 (5.08)	3.81
0.400 (10.16)	7.62
0.170 (4.32)	
0.220 (5.59)	
0.275 (6.98)	
0.300 (7.62)	
0.375 (9.52)	
0.475 (12.06)	
0.575 (14.60)	
0.675 (17.14)	

Packaging Quantities

Style/ Size	Standard Bulk Quantity	Ammo Pack Quantity Maximum	Reel Quantity Maximum (12" Reel)
114	200/Box	N/A	5000
124	200/Box		5000
192	100/Box		3000
202	25/Box		500
222	10/Tray		300

Marking

KC0G	—	KEMET, Temperature Characteristic
101J	—	Capacitance, Capacitance Tolerance
200V	—	Voltage
0812	—	Date Code

Tape & Reel Packaging Information

KEMET offers standard reeling of molded and conformally coated axial leaded ceramic capacitors for automatic insertion or lead forming machines in accordance with EIA standard 296. KEMET’s internal specification four-digit suffix, 7200, is placed at the end of the part number to designate tape and reel packaging, e.g., C410C104Z5U5CA7200.

Paper (50 lb.) test minimum is inserted between the layers of capacitors wound on reels for component pitch $\leq 0.400"$. Capacitor lead length may extend only a maximum of $.0625"$ (1.59 mm) beyond the tapes’ edges. Capacitors are centered in a row between the two tapes and will deviate only $\pm 0.031"$ (0.79 mm) from the row center. A minimum of 36" (91.5 cm) leader tape is provided at each finished length of taped components. Universal splicing clips are used to connect the tape.

Figure 1

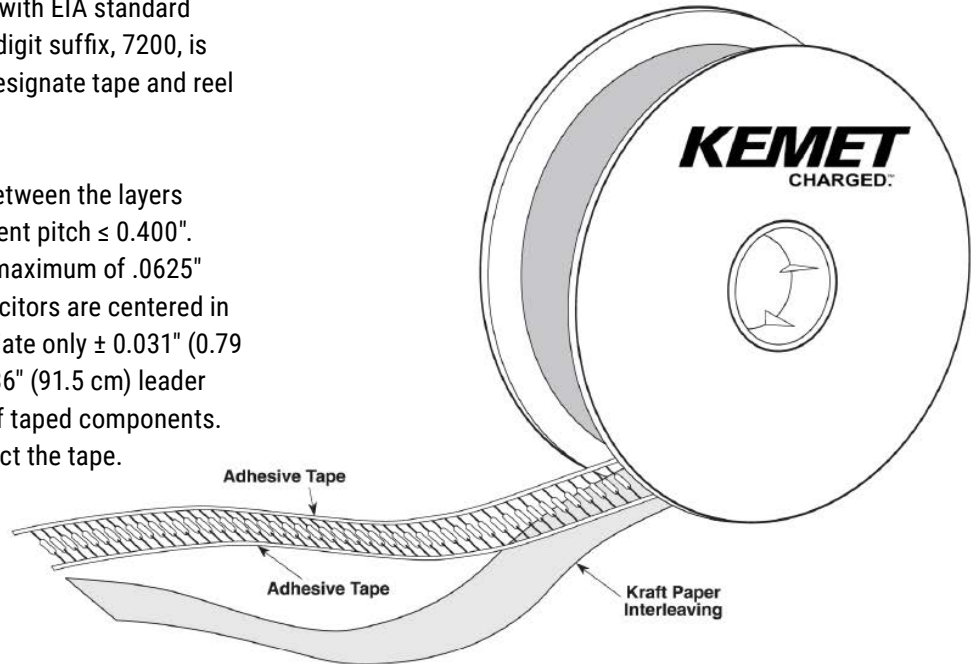

Figure 2

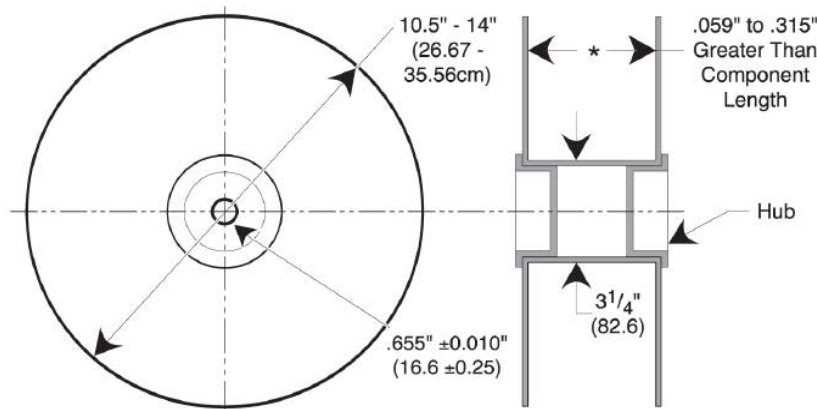

Figure 3

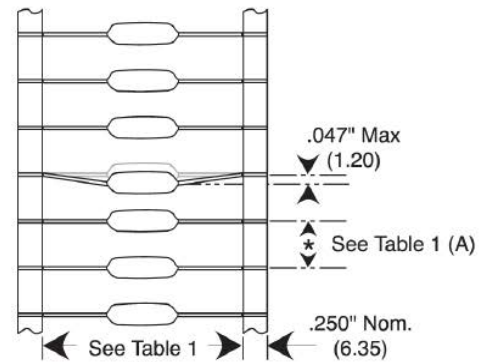

Table 3 – Ceramic Axial Tape and Reel Dimensions

Metric will govern

Dimensions – Millimeters (Inches)		
Axial Capacitor Body Diameter	A	B
	± 0.5 (0.020)	± 1.5 (0.059)*
0.0 to 5.0 (0.0 to 0.197)	5.0 (0.197)	52.4 (2.062)

Symbol Reference Table	
A	Component Pitch
B	Inside Tape Spacing

* Inside tape spacing dimension (B) is determined by the body diameter of the capacitor.

KEMET Electronic Corporation Sales Offices

For a complete list of our global sales offices, please visit www.kemet.com/sales.

Disclaimer

All product specifications, statements, information and data (collectively, the "Information") in this datasheet are subject to change. The customer is responsible for checking and verifying the extent to which the Information contained in this publication is applicable to an order at the time the order is placed.

All Information given herein is believed to be accurate and reliable, but it is presented without guarantee, warranty, or responsibility of any kind, expressed or implied.

Statements of suitability for certain applications are based on KEMET Electronics Corporation's ("KEMET") knowledge of typical operating conditions for such applications, but are not intended to constitute – and KEMET specifically disclaims – any warranty concerning suitability for a specific customer application or use. The Information is intended for use only by customers who have the requisite experience and capability to determine the correct products for their application. Any technical advice inferred from this Information or otherwise provided by KEMET with reference to the use of KEMET's products is given gratis, and KEMET assumes no obligation or liability for the advice given or results obtained.

Although KEMET designs and manufactures its products to the most stringent quality and safety standards, given the current state of the art, isolated component failures may still occur. Accordingly, customer applications which require a high degree of reliability or safety should employ suitable designs or other safeguards (such as installation of protective circuitry or redundancies) in order to ensure that the failure of an electrical component does not result in a risk of personal injury or property damage.

Although all product-related warnings, cautions and notes must be observed, the customer should not assume that all safety measures are indicated or that other measures may not be required.