

END TO END	"L"
DV TO DV	950[24.13]
DV TO EM (-TEX)	835[21.21]
DV TO EM (-SEX)	806[20.48]
EM (-TEX) TO EM (-TEX)	720[18.29]
EM (-TEX) TO EM (-SEX)	691[17.55]
EM (-SEX) TO EM (-SEX)	662[16.81]
DV-N TO DV-N	840[21.34]
DV-N TO EM (-TEX)	780[19.81]
DV-N TO EM (-SEX)	751[19.08]

DO NOT SCALE FROM THIS PRINT

FIG 1
VERTICAL
(HQCD-060-XX.XX-STR-STR-1 SHOWN)

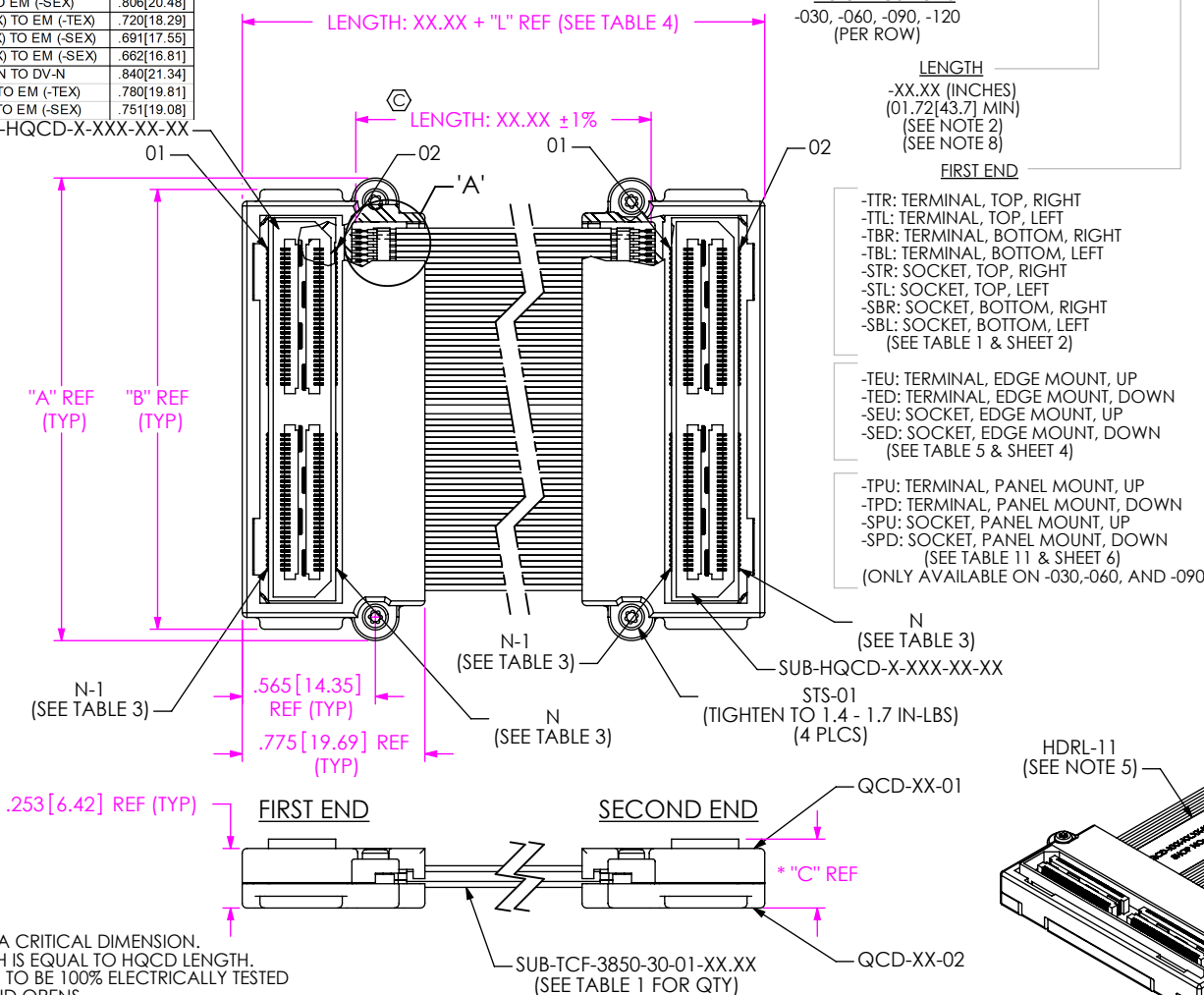

HQCD-XXX-XX.XX-XXX-XXX-X-X

THIS PRODUCT MANUFACTURED WITH LEAD-FREE PROCESSING

- No OF POSITIONS**
-030, -060, -090, -120 (PER ROW)
- LENGTH**
-XX.XX (INCHES)
(01.72[43.7] MIN)
(SEE NOTE 2)
(SEE NOTE 8)
- FIRST END**
- TR: TERMINAL, TOP, RIGHT
 - TTL: TERMINAL, TOP, LEFT
 - TBR: TERMINAL, BOTTOM, RIGHT
 - TBL: TERMINAL, BOTTOM, LEFT
 - STR: SOCKET, TOP, RIGHT
 - STL: SOCKET, TOP, LEFT
 - SBR: SOCKET, BOTTOM, RIGHT
 - SBL: SOCKET, BOTTOM, LEFT (SEE TABLE 1 & SHEET 2)
- TEU: TERMINAL, EDGE MOUNT, UP
-TED: TERMINAL, EDGE MOUNT, DOWN
-SEU: SOCKET, EDGE MOUNT, UP
-SED: SOCKET, EDGE MOUNT, DOWN (SEE TABLE 5 & SHEET 4)
- TPU: TERMINAL, PANEL MOUNT, UP
-TPD: TERMINAL, PANEL MOUNT, DOWN
-SPU: SOCKET, PANEL MOUNT, UP
-SPD: SOCKET, PANEL MOUNT, DOWN (SEE TABLE 11 & SHEET 6)
(ONLY AVAILABLE ON -030, -060, AND -090)

- END OPTION**
- F: SCREW OPTION FIRST END ONLY (NOT AVAILABLE WITH XPX OPTIONS)
 - S: SCREW OPTION SECOND END ONLY
 - B: SCREW OPTION BOTH ENDS (NOT AVAILABLE WITH XPX OPTIONS)
 - N: NO HOUSINGS BOTH ENDS
 - L: FIRST END RT1 OPTION (SEE NOTES 9 & 10)
 - R: SECOND END RT1 OPTION (SEE NOTES 9 & 10)
 - D: BOTH ENDS RT1 OPTION (SEE NOTES 9 & 10)
 - 1: FIRST END SCREW OPTION, SECOND END RT1 OPTION (SEE NOTES 9 & 10)
 - 2: FIRST END RT1 OPTION, SECOND END SCREW OPTION (SEE NOTES 9 & 10) (SEE FIG 3, SHEET 5 FOR EDGE MOUNT END OPTIONS)
 - (SEE FIG 4, SHEET 5 FOR DOUBLE VERTICAL END OPTIONS)
 - (SEE FIG 5, SHEET 5 FOR NO HOUSINGS) (LEAVE BLANK FOR STANDARD HOUSINGS BOTH ENDS)
- WIRING OPTION**
- 1: PIN 1 TO PIN 1
 - 2: PIN 1 TO PIN 2
 - 3: PIN 1 TO PIN N-1
 - 4: PIN 1 TO PIN N (SEE TABLE 9, SHEET 8)
- SECOND END**
- TR: TERMINAL, TOP, RIGHT
 - TTL: TERMINAL, TOP, LEFT
 - TBR: TERMINAL, BOTTOM, RIGHT
 - TBL: TERMINAL, BOTTOM, LEFT
 - STR: SOCKET, TOP, RIGHT
 - STL: SOCKET, TOP, LEFT
 - SBR: SOCKET, BOTTOM, RIGHT
 - SBL: SOCKET, BOTTOM, LEFT (SEE TABLE 1 & SHEET 3)
- TEU: TERMINAL, EDGE MOUNT, UP
-TED: TERMINAL, EDGE MOUNT, DOWN
-SEU: SOCKET, EDGE MOUNT, UP
-SED: SOCKET, EDGE MOUNT, DOWN (SEE TABLE 5 & SHEET 4)

No. OF POSITIONS	N	N-1
-030	60	59
-060	120	119
-090	180	179
-120	240	239

- NOTES:**
- ⊙ REPRESENTS A CRITICAL DIMENSION.
 - SUB-TCF LENGTH IS EQUAL TO HQCD LENGTH.
 - ⊙ ALL ASSEMBLIES TO BE 100% ELECTRICALLY TESTED FOR SHORTS AND OPENS.
 - ⊙ ALL ASSEMBLIES TO BE 100% HI-POT TESTED AT 300V.
 - TOP SUB-TCF NOT SHOWN IN THIS VIEW FOR CLARITY; HDRL-11 TO BE CENTERED ON LOWER SUB-TCF AS SHOWN; HDRL-11 IS TO CONTAIN:
LINE 1 - PART NUMBER "HQCD-XXX-XX.XX-XXX-XXX-X-X"
LINE 2 - SHOP ORDER NUMBER "XXXXXX"
LINE 3 - DATE CODE "XXXXX"
 - FOR PACKAGING REQUIREMENTS REFERENCE PACKAGING STANDARDS.
 - PARTS TO BE PROCESSED PER SAMTEC ACCEPTABILITY REQUIREMENTS: HDR-P1-01 "CABLE ASSEMBLY WORKMANSHIP STANDARDS".
 - CABLE LENGTHS LONGER THAN 40.00 INCHES ARE NOT SUPPORTED BY S.I. TEST DATA.
 - RT1 OPTION IS NOT AVAILABLE WITH EDGEMOUNT OR PANEL MOUNT END OPTIONS.
 - RT1 OPTION IS NOT AVAILABLE WITH -120 POSITIONS.
 - ALL POSITIONS TRANSMITTED AS SIGNALS ACROSS COAX CENTER CONDUCTORS. CONNECTOR GROUND BLADE TIED TO COAX SHIELD. FOR MULTIPLE BANK ASSEMBLIES, EASH BANK IS GROUND INDEPENDENT OF THE OTHERS.
 - REFER TO PREP-SPEC DRAWING FOR CABLE PREP DIMENSIONS. ASSEMBLY USES STANDARD PCB PREP.

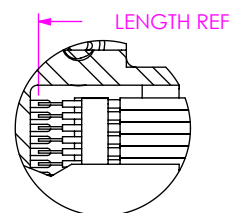
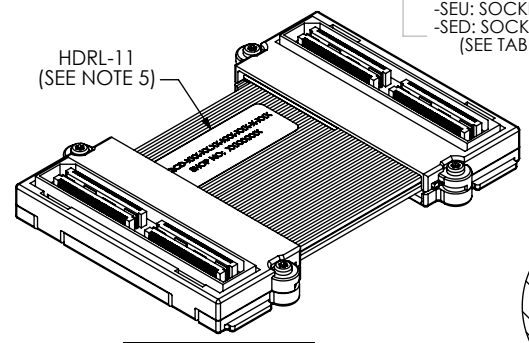

DETAIL 'A'
SCALE 2.5 : 1

No. OF POSITIONS	"A"	"B"	QCD-XX-01	QCD-XX-02	QTY OF SUB-TCF	SUB-HQCD-X-XXX-XX-XX
-030	1.175[29.85]	1.078[27.38]	QCD-01-01	QCD-01-02	2	SUB-HQCD-X-030-XX-XX
-060	1.963[49.85]	1.866[47.40]	QCD-02-01	QCD-02-02	4	SUB-HQCD-X-060-XX-XX
-090	2.750[69.85]	2.653[67.39]	QCD-03-01	QCD-03-02	6	SUB-HQCD-X-090-XX-XX
-120	3.538[89.85]	3.441[87.39]	QCD-04-01	QCD-04-02	8	SUB-HQCD-X-120-XX-XX

ASSEMBLY OPERATION	IN-PROCESS INSPECTION
PREP CABLE	C3
E-TEST	C1, C2

END	* "C"
-TX	.333[8.46]
-SX	.296[7.52]

* -DV END OPTIONS ONLY

UNLESS OTHERWISE SPECIFIED, DIMENSIONS ARE IN INCHES. TOLERANCES ARE:
DECIMALS ANGLES
.XX: ±.01 [.3] 2°
.XXX: ±.005 [.13]
.XXXX: ±.0020 [.051]

PROPRIETARY NOTE
THIS DOCUMENT CONTAINS CONFIDENTIAL AND PROPRIETARY INFORMATION AND ALL DESIGN, MANUFACTURING, REPRODUCTION, USE, PATENT RIGHTS AND SALES RIGHTS ARE EXPRESSLY RESERVED BY SAMTEC, INC. THIS DOCUMENT SHALL NOT BE DISCLOSED, IN WHOLE OR PART, TO ANY UNAUTHORIZED PERSON OR ENTITY NOR REPRODUCED, TRANSFERRED OR INCORPORATED IN ANY OTHER PROJECT IN ANY MANNER WITHOUT THE EXPRESS WRITTEN CONSENT OF SAMTEC, INC.

MATERIAL: DO NOT SCALE DRAWING
PLATING: SHEET SCALE: 1:0.8
-H GOLD: 30µ CONTACT

DESCRIPTION:
0.5mm HIGH-SPEED COAX CABLE ASSEMBLY
DWG. NO.
HQCD-XXX-XX.XX-XXX-XXX-X-X
BY: KEVIN B 04/29/03 **SHEET 1 OF 8**

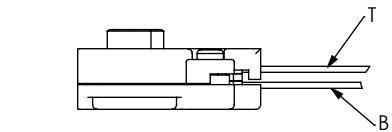
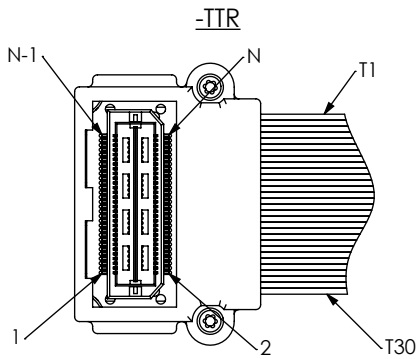

WIRING OPTION	FIRST END PIN #	SECOND END PIN #	WIRE NUMBER
1	1	1	B30
2	1	2	B30
3	1	N-1	B30
4	1	N	B30

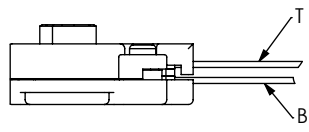
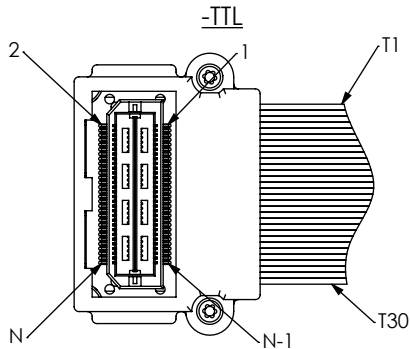

WIRING OPTION	FIRST END PIN #	SECOND END PIN #	WIRE NUMBER
1	1	1	T1
2	1	2	T1
3	1	N-1	T1
4	1	N	T1

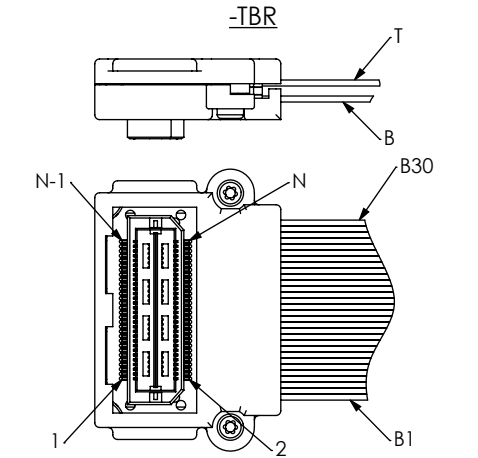

WIRING OPTION	FIRST END PIN #	SECOND END PIN #	WIRE NUMBER
1	1	1	T1
2	1	2	T1
3	1	N-1	T1
4	1	N	T1

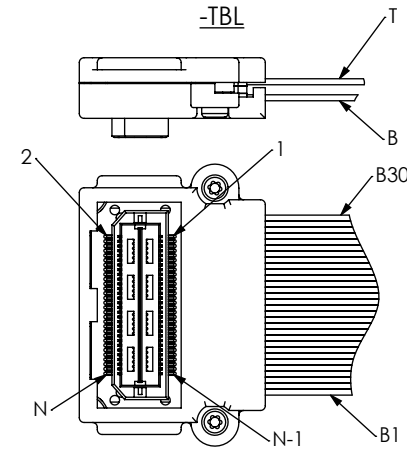

WIRING OPTION	FIRST END PIN #	SECOND END PIN #	WIRE NUMBER
1	1	1	B30
2	1	2	B30
3	1	N-1	B30
4	1	N	B30

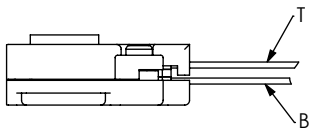
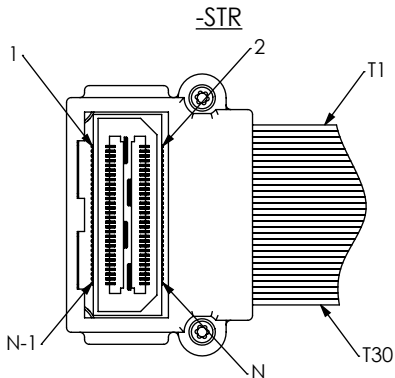

WIRING OPTION	FIRST END PIN #	SECOND END PIN #	WIRE NUMBER
1	1	1	B1
2	1	2	B1
3	1	N-1	B1
4	1	N	B1

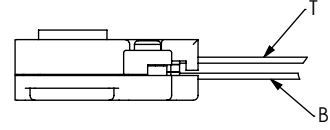
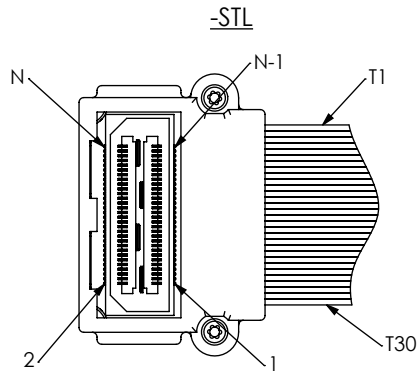

WIRING OPTION	FIRST END PIN #	SECOND END PIN #	WIRE NUMBER
1	1	1	T30
2	1	2	T30
3	1	N-1	T30
4	1	N	T30

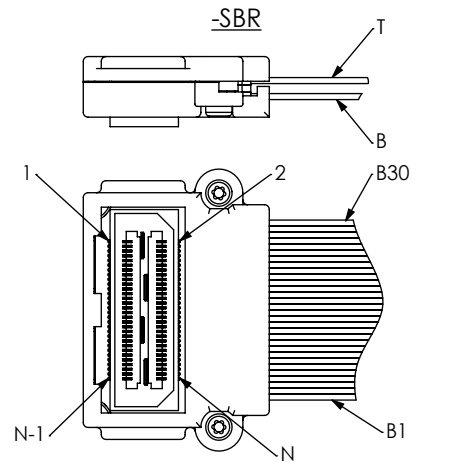

WIRING OPTION	FIRST END PIN #	SECOND END PIN #	WIRE NUMBER
1	1	1	T30
2	1	2	T30
3	1	N-1	T30
4	1	N	T30

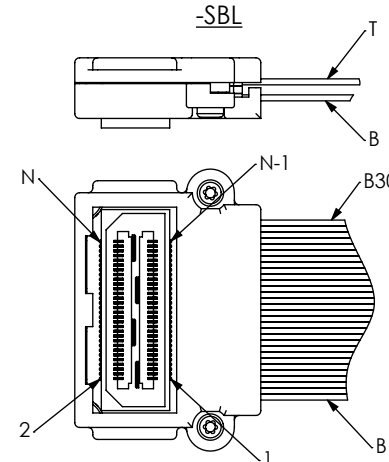

WIRING OPTION	FIRST END PIN #	SECOND END PIN #	WIRE NUMBER
1	1	1	B1
2	1	2	B1
3	1	N-1	B1
4	1	N	B1

PROPRIETARY NOTE
 THIS DOCUMENT CONTAINS CONFIDENTIAL AND PROPRIETARY INFORMATION AND ALL DESIGN, MANUFACTURING, REPRODUCTION, USE, PATENT RIGHTS AND SALES RIGHTS ARE EXPRESSLY RESERVED BY SAMTEC, INC. THIS DOCUMENT SHALL NOT BE DISCLOSED, IN WHOLE OR PART, TO ANY UNAUTHORIZED PERSON OR ENTITY NOR REPRODUCED, TRANSFERRED OR INCORPORATED IN ANY OTHER PROJECT IN ANY MANNER WITHOUT THE EXPRESS WRITTEN CONSENT OF SAMTEC, INC.

DO NOT SCALE DRAWING

SHEET SCALE: 1:25:1



520 PARK EAST BLVD, NEW ALBANY, IN 47150
 PHONE: 812-944-6733 FAX: 812-948-5047
 e-Mail: info@SAMTEC.com code: 55322

DESCRIPTION:
 0.5mm HIGH-SPEED COAX CABLE ASSEMBLY

DWG. NO.
 HQCD-XXX-XX.XX-XXX-XXX-X-X

BY: KEVIN B 04/29/03 SHEET 2 OF 8

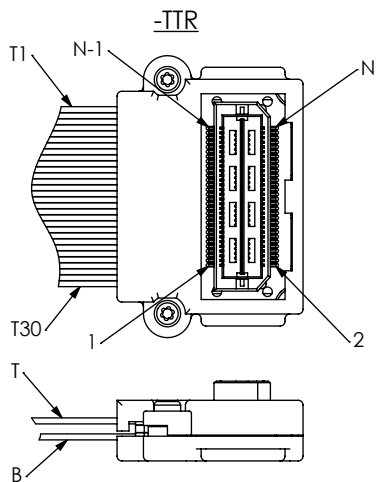

WIRING OPTION	FIRST END PIN #	SECOND END PIN #
1	1	1
2	1	2
3	1	N-1
4	1	N

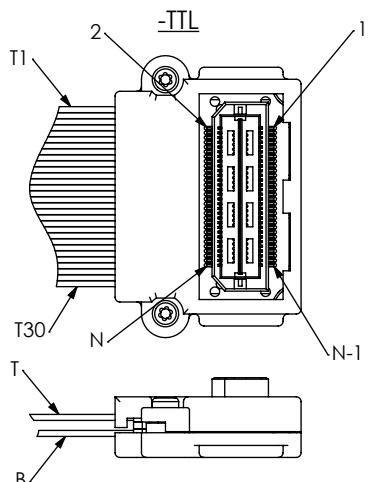

WIRING OPTION	FIRST END PIN #	SECOND END PIN #
1	1	1
2	1	2
3	1	N-1
4	1	N

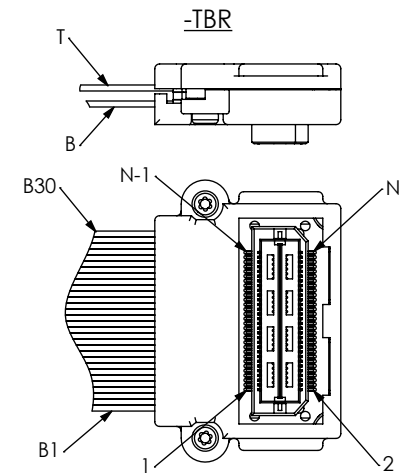

WIRING OPTION	FIRST END PIN #	SECOND END PIN #
1	1	1
2	1	2
3	1	N-1
4	1	N

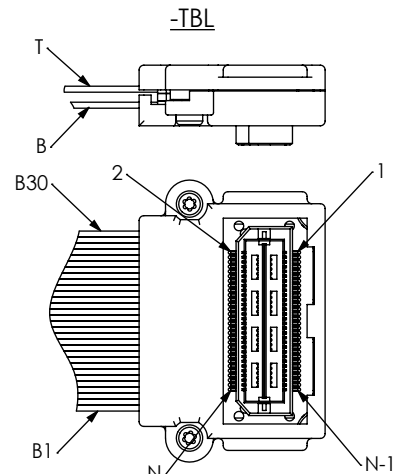

WIRING OPTION	FIRST END PIN #	SECOND END PIN #
1	1	1
2	1	2
3	1	N-1
4	1	N

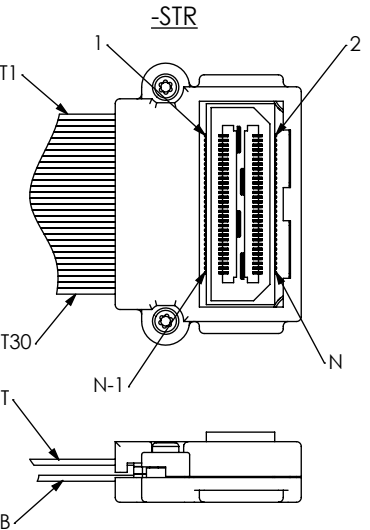

WIRING OPTION	FIRST END PIN #	SECOND END PIN #
1	1	1
2	1	2
3	1	N-1
4	1	N

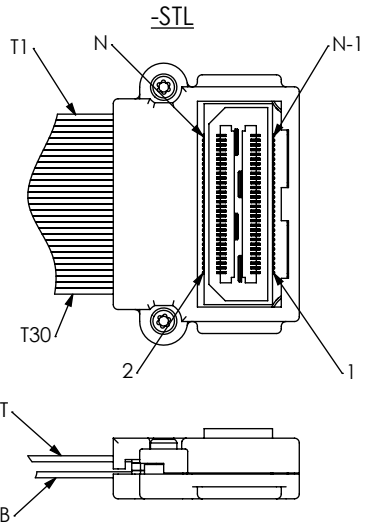

WIRING OPTION	FIRST END PIN #	SECOND END PIN #
1	1	1
2	1	2
3	1	N-1
4	1	N

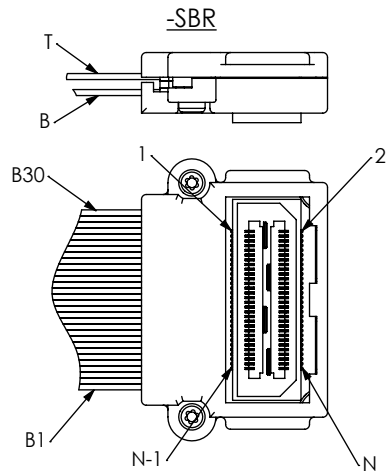

WIRING OPTION	FIRST END PIN #	SECOND END PIN #
1	1	1
2	1	2
3	1	N-1
4	1	N

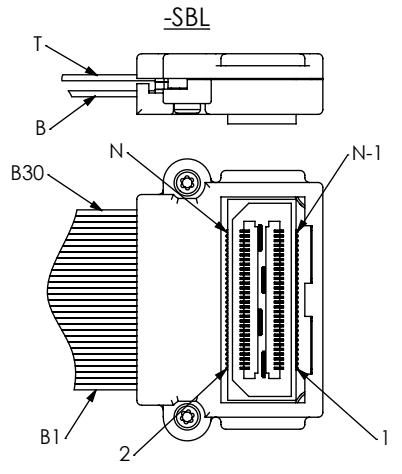

WIRING OPTION	FIRST END PIN #	SECOND END PIN #
1	1	1
2	1	2
3	1	N-1
4	1	N

PROPRIETARY NOTE
 THIS DOCUMENT CONTAINS CONFIDENTIAL AND PROPRIETARY INFORMATION AND ALL DESIGN, MANUFACTURING, REPRODUCTION, USE, PATENT RIGHTS AND SALES RIGHTS ARE EXPRESSLY RESERVED BY SAMTEC, INC. THIS DOCUMENT SHALL NOT BE DISCLOSED, IN WHOLE OR PART, TO ANY UNAUTHORIZED PERSON OR ENTITY NOR REPRODUCED, TRANSFERRED OR INCORPORATED IN ANY OTHER PROJECT IN ANY MANNER WITHOUT THE EXPRESS WRITTEN CONSENT OF SAMTEC, INC.

DO NOT SCALE DRAWING

SHEET SCALE: 1:25:1



520 PARK EAST BLVD, NEW ALBANY, IN 47150
 PHONE: 812-944-6733 FAX: 812-948-5047
 e-Mail: info@SAMTEC.com code: 55322

DESCRIPTION:
 0.5mm HIGH-SPEED COAX CABLE ASSEMBLY

DWG. NO.
 HQCD-XXX-XX.XX-XXX-XXX-X-X

BY: KEVIN B 04/29/03 SHEET 3 OF 8

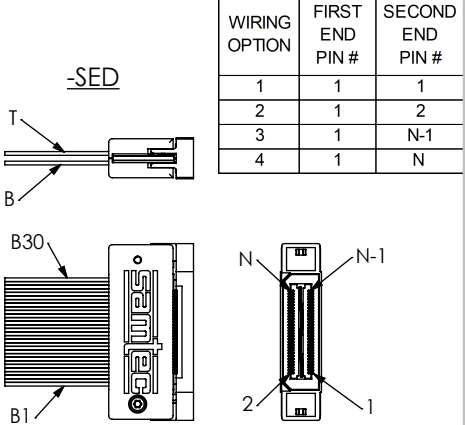
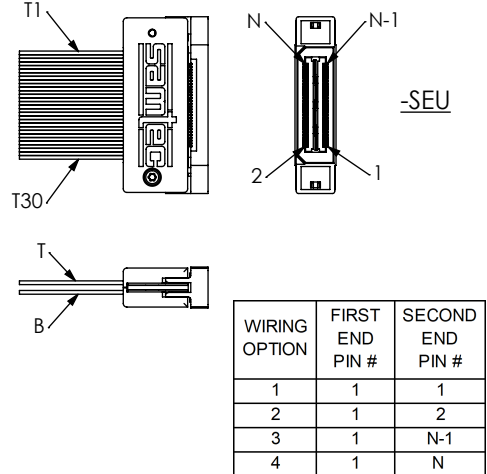
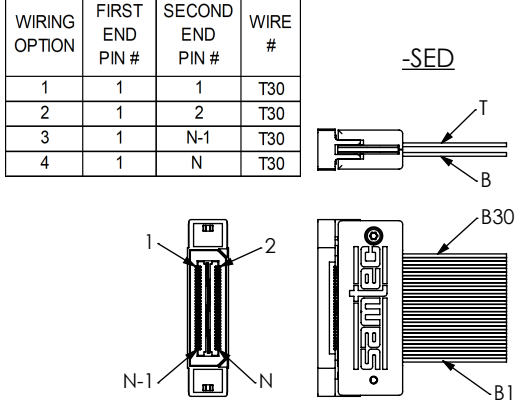
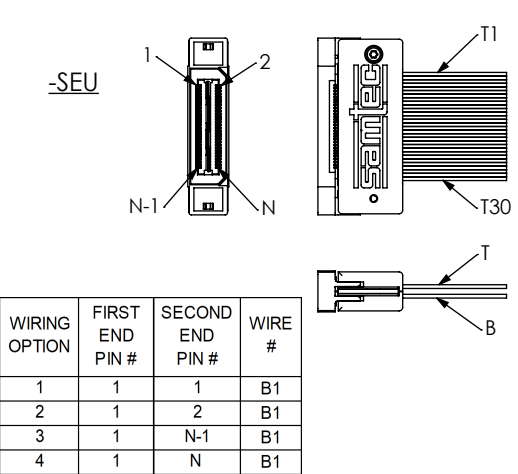
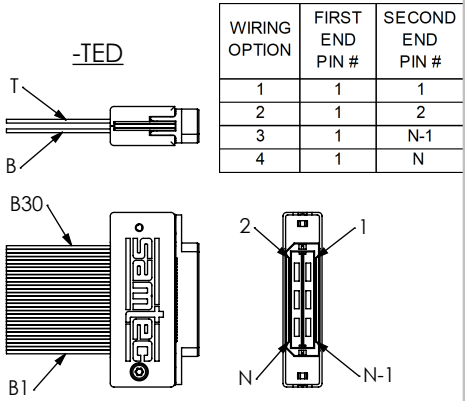
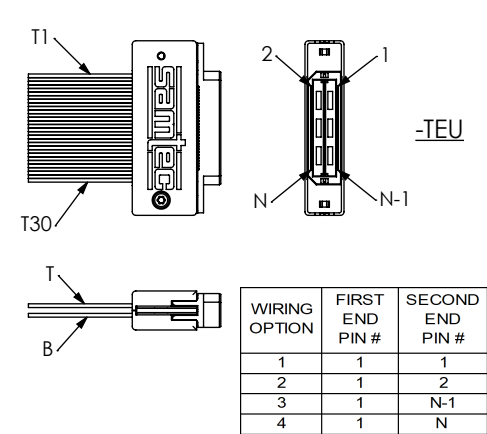
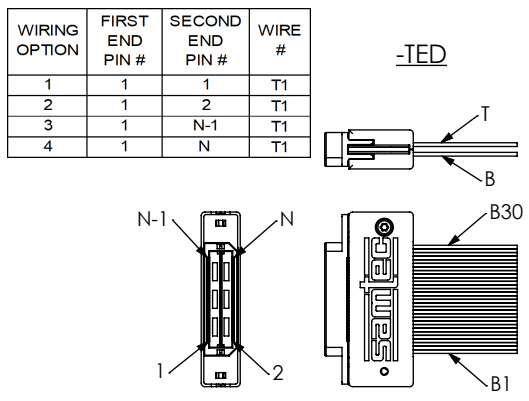
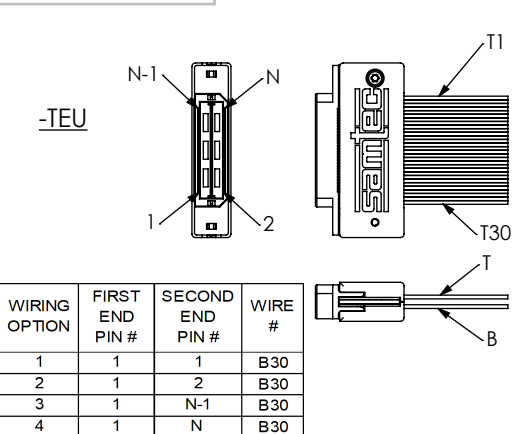

FIG 2
EDGE MOUNT (NO CAPTIVE PANEL SCREWS)
(HQCD-030-XX.XX-TEU-STR-X SHOWN)
(SAME AS FIG 1, UNLESS OTHERWISE STATED)

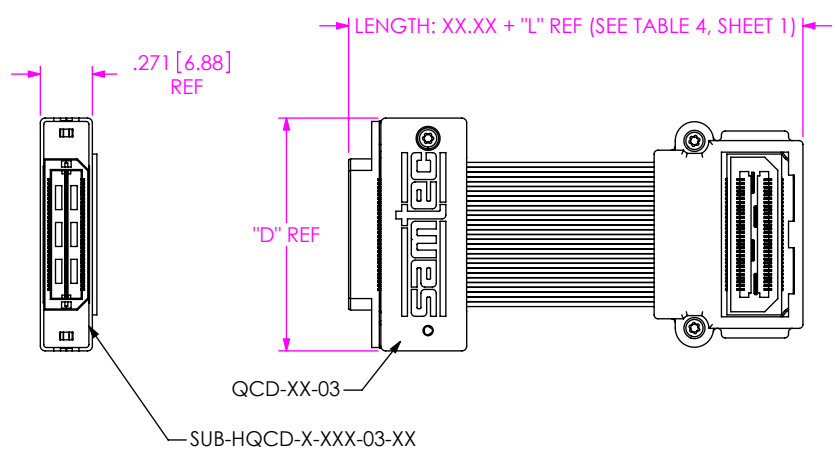

TABLE 5

No. OF POSITIONS	"D"	QCD-XXX-03	SUB-HQCD-X-XXX-XX-XX
-030	1.213[30.80]	QCD-01-03	SUB-HQCD-X-030-03-XX
-060	2.000[50.80]	QCD-02-03	SUB-HQCD-X-060-03-XX
-090	2.788[70.80]	QCD-03-03	SUB-HQCD-X-090-03-XX
-120	3.575[90.80]	QCD-04-03	SUB-HQCD-X-120-03-XX

PROPRIETARY NOTE
THIS DOCUMENT CONTAINS CONFIDENTIAL AND PROPRIETARY INFORMATION AND ALL DESIGN, MANUFACTURING, REPRODUCTION, USE, PATENT RIGHTS AND SALES RIGHTS ARE EXPRESSLY RESERVED BY SAMTEC, INC. THIS DOCUMENT SHALL NOT BE DISCLOSED, IN WHOLE OR PART, TO ANY UNAUTHORIZED PERSON OR ENTITY NOR REPRODUCED, TRANSFERRED OR INCORPORATED IN ANY OTHER PROJECT IN ANY MANNER WITHOUT THE EXPRESS WRITTEN CONSENT OF SAMTEC, INC.



520 PARK EAST BLVD, NEW ALBANY, IN 47150
PHONE: 812-944-6733 FAX: 812-948-5047
e-Mail: info@SAMTEC.com code: 55322

DO NOT SCALE DRAWING

DESCRIPTION:
0.5mm HIGH-SPEED COAX CABLE ASSEMBLY

DWG. NO.
HQCD-XXX-XX.XX-XXX-XXX-X-X

BY: KEVIN B 04/29/03 SHEET 4 OF 8

SHEET SCALE: 1:1

FIG 3

EDGE MOUNT (WITH CAPTIVE PANEL SCREWS)
(HQCD-030-XX.XX-SEU-XXX-1-F SHOWN)
(SAME AS FIG 2, UNLESS OTHERWISE STATED)

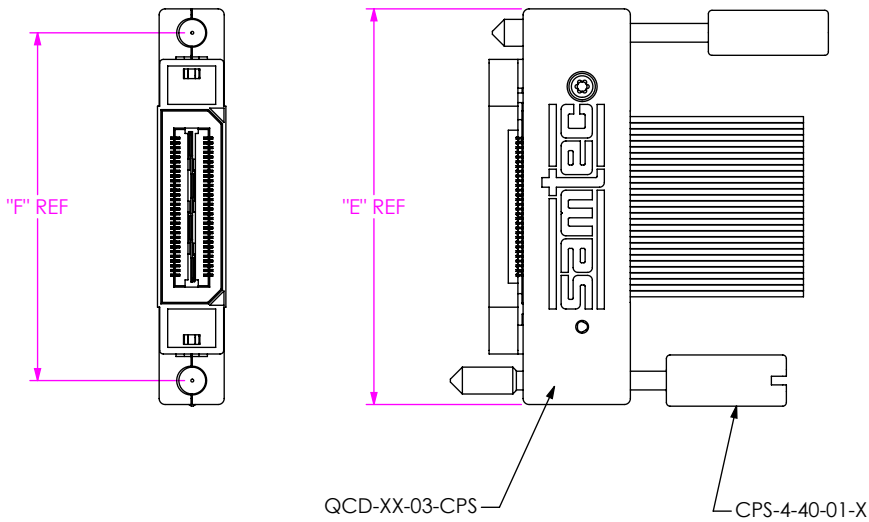

TABLE 6

No. OF POSITIONS	"E"	"F"	QCD-XX-03-CPS
-030	1.649[41.87]	1.449[36.80]	QCD-01-03-CPS
-060	2.436[61.87]	2.237[56.80]	QCD-02-03-CPS
-090	3.224[81.87]	3.024[76.80]	QCD-03-03-CPS
-120	4.011[101.87]	3.812[96.80]	QCD-04-03-CPS

FIG 4

DOUBLE VERTICAL (WITH SCREW DOWN OPTION)
(HQCD-030-XX.XX-TTR-XXX-1-F SHOWN)
(SAME AS FIG 1, UNLESS OTHERWISE STATED)

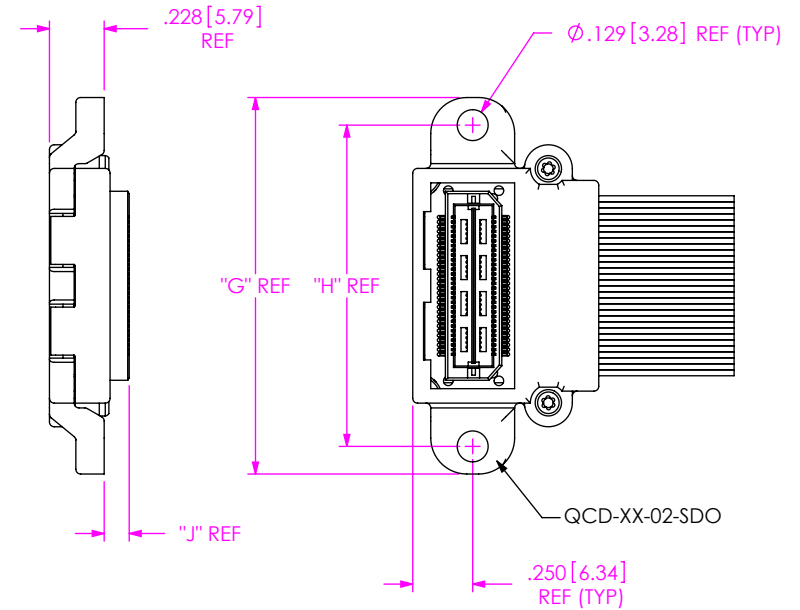

TABLE 7

No. OF POSITIONS	"G"	"H"	QCD-XX-02-SDO
-030	1.569[39.85]	1.339[34.00]	QCD-01-02-SDO
-060	2.356[59.84]	2.126[54.00]	QCD-02-02-SDO
-090	3.144[79.86]	2.913[74.00]	QCD-03-02-SDO
-120	3.931[99.85]	3.701[94.00]	QCD-04-02-SDO

TABLE 8

END	"J"
-TXX	.104[2.65]
-SXX	.068[1.73]

FIG 5

(HQCD-XXX-XX.XX-TEU-STR-1-N SHOWN)
(SAME AS FIG 1 EXCEPT AS SHOWN)

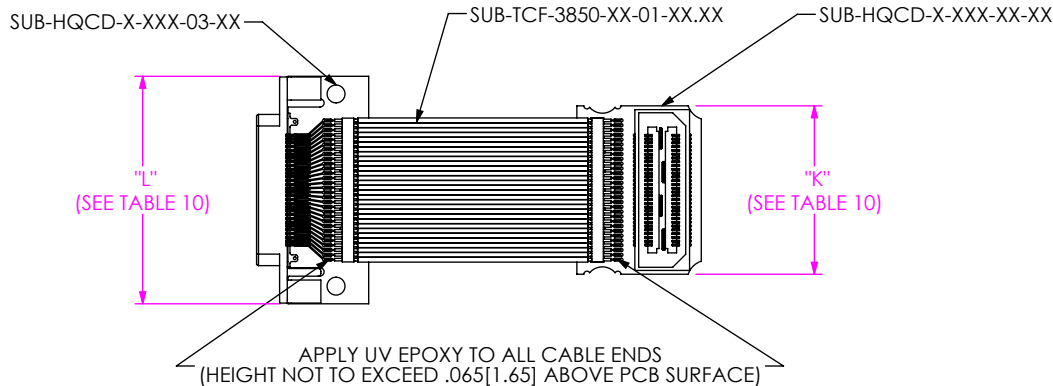

TABLE 10

No OF POSITIONS	"K"	"L"
030	0.877 [22.28]	1.1850 [30.10]
060	1.665 [42.29]	1.9730 [50.11]
090	2.453 [62.31]	2.7600 [70.10]
120	3.240 [82.30]	3.5480 [90.12]

PROPRIETARY NOTE

THIS DOCUMENT CONTAINS CONFIDENTIAL AND PROPRIETARY INFORMATION AND ALL DESIGN, MANUFACTURING, REPRODUCTION, USE, PATENT RIGHTS AND SALES RIGHTS ARE EXPRESSLY RESERVED BY SAMTEC, INC. THIS DOCUMENT SHALL NOT BE DISCLOSED, IN WHOLE OR PART, TO ANY UNAUTHORIZED PERSON OR ENTITY NOR REPRODUCED, TRANSFERRED OR INCORPORATED IN ANY OTHER PROJECT IN ANY MANNER WITHOUT THE EXPRESS WRITTEN CONSENT OF SAMTEC, INC.



520 PARK EAST BLVD, NEW ALBANY, IN 47150
PHONE: 812-944-6733 FAX: 812-948-5047
e-Mail: info@SAMTEC.com code: 55322

DO NOT SCALE DRAWING

DESCRIPTION:
0.5mm HIGH-SPEED COAX CABLE ASSEMBLY

DWG. NO.
HQCD-XXX-XX.XX-XXX-XXX-X-X

BY: KEVIN B 04/29/03 SHEET 5 OF 8

SHEET SCALE: 1.25:1

FIRST END - PANEL MOUNT (SEE TABLE 9, SHEET 8)

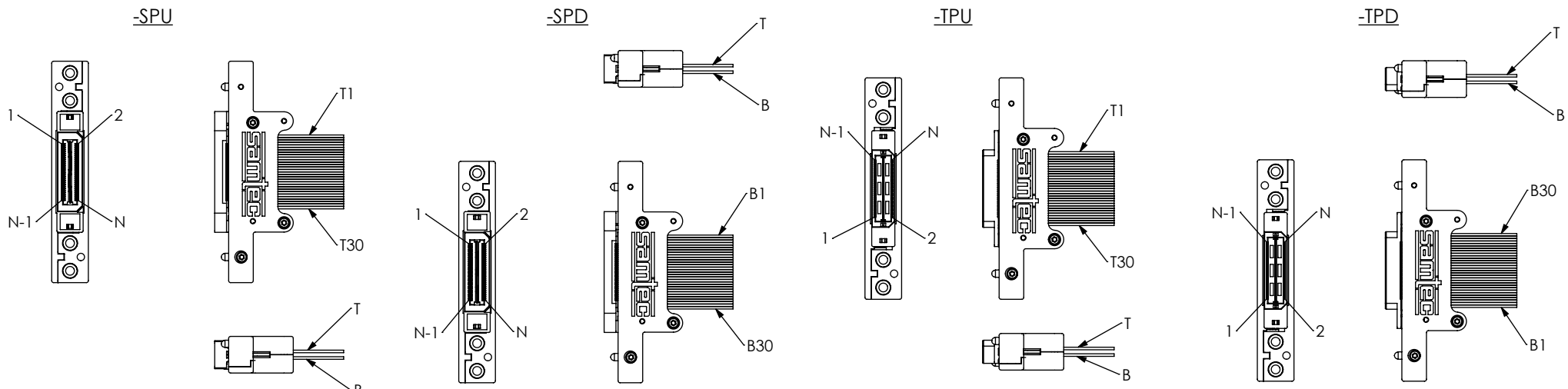

WIRING OPTION	FIRST END PIN #	SECOND END PIN #	WIRE #
1	1	1	B1
2	1	2	B1
3	1	N-1	B1
4	1	N	B1

WIRING OPTION	FIRST END PIN #	SECOND END PIN #	WIRE #
1	1	1	T1
2	1	2	T1
3	1	N-1	T1
4	1	N	T1

WIRING OPTION	FIRST END PIN #	SECOND END PIN #	WIRE #
1	1	1	B30
2	1	2	B30
3	1	N-1	B30
4	1	N	B30

WIRING OPTION	FIRST END PIN #	SECOND END PIN #	WIRE #
1	1	1	T1
2	1	2	T1
3	1	N-1	T1
4	1	N	T1

FIG 6

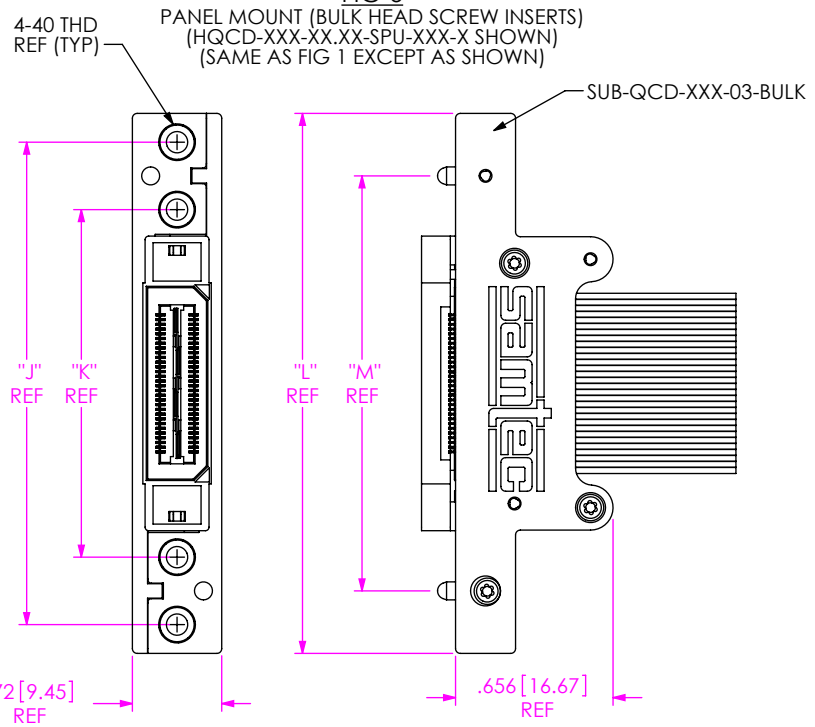

No. OF POSITIONS	"J"		"K"		"L"		"M"		SUB-QCD-XXX-03-BULK
-030	2.010	[51.05]	1.449	[36.80]	2.250	[57.15]	1.73	[43.94]	SUB-QCD-01-03-BULK
-060	2.798	[71.07]	2.237	[56.82]	3.038	[77.17]	2.518	[63.96]	SUB-QCD-02-03-BULK
-090	3.586	[91.08]	3.024	[76.81]	3.826	[97.18]	3.306	[83.97]	SUB-QCD-03-03-BULK

PROPRIETARY NOTE
 THIS DOCUMENT CONTAINS CONFIDENTIAL AND PROPRIETARY INFORMATION AND ALL DESIGN, MANUFACTURING, REPRODUCTION, USE, PATENT RIGHTS AND SALES RIGHTS ARE EXPRESSLY RESERVED BY SAMTEC, INC. THIS DOCUMENT SHALL NOT BE DISCLOSED, IN WHOLE OR PART, TO ANY UNAUTHORIZED PERSON OR ENTITY NOR REPRODUCED, TRANSFERRED OR INCORPORATED IN ANY OTHER PROJECT IN ANY MANNER WITHOUT THE EXPRESS WRITTEN CONSENT OF SAMTEC, INC.



520 PARK EAST BLVD, NEW ALBANY, IN 47150
 PHONE: 812-944-6733 FAX: 812-948-5047
 e-Mail: info@SAMTEC.com code: 55322

DO NOT SCALE DRAWING

DESCRIPTION:
 0.5mm HIGH-SPEED COAX CABLE ASSEMBLY

DWG. NO.
 HQCD-XXX-XX.XX-XXX-XXX-X-X

SHEET SCALE: 1.25:1

BY: KEVIN B 04/29/03 SHEET 6 OF 8

FIG 7
 (HQCD-030-XX.XX-TTL-STR-D SHOWN)
 (SAME AS FIG 1 EXCEPT AS SHOWN)

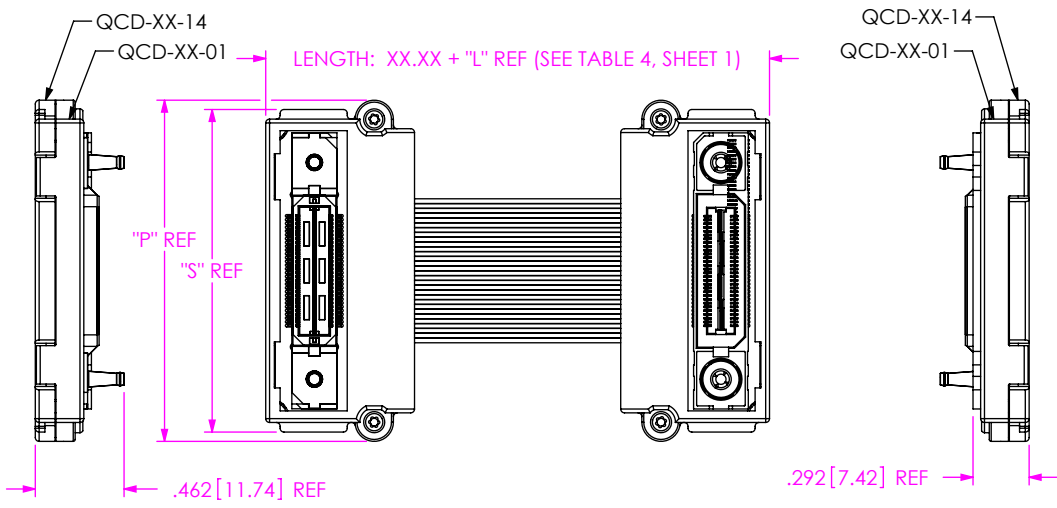

TABLE 12

No. OF POSITIONS	"P"		"S"		QCD-XX-01	QCD-XX-14	SUB-HQCD-X-XXX-XX-XX-RT1
-030	1.777	[45.14]	1.680	[42.67]	QCD-07-01	QCD-01-14	SUB-HQCD-X-030-XX-XX-RT1
-060	2.565	[65.15]	2.468	[62.69]	QCD-08-01	QCD-02-14	SUB-HQCD-X-060-XX-XX-RT1
-090	3.352	[85.14]	3.255	[82.68]	QCD-09-01	QCD-03-14	SUB-HQCD-X-090-XX-XX-RT1
-120	4.140	[105.16]	4.043	[102.69]	QCD-10-01	QCD-04-14	SUB-HQCD-X-120-XX-XX-RT1

<p>DO NOT SCALE DRAWING</p> <p>SHEET SCALE: 1:1</p>	<p>PROPRIETARY NOTE</p> <p>THIS DOCUMENT CONTAINS CONFIDENTIAL AND PROPRIETARY INFORMATION AND ALL DESIGN, MANUFACTURING, REPRODUCTION, USE, PATENT RIGHTS AND SALES RIGHTS ARE EXPRESSLY RESERVED BY SAMTEC, INC. THIS DOCUMENT SHALL NOT BE DISCLOSED, IN WHOLE OR PART, TO ANY UNAUTHORIZED PERSON OR ENTITY NOR REPRODUCED, TRANSFERRED OR INCORPORATED IN ANY OTHER PROJECT IN ANY MANNER WITHOUT THE EXPRESS WRITTEN CONSENT OF SAMTEC, INC.</p>	<p>520 PARK EAST BLVD, NEW ALBANY, IN 47150 PHONE: 812-944-6733 FAX: 812-948-5047 e-Mail: info@SAMTEC.com code: 55322</p>
	<p>DESCRIPTION: 0.5mm HIGH-SPEED COAX CABLE ASSEMBLY</p> <p>DWG. NO. HQCD-XXX-XX.XX-XXX-XXX-X-X</p>	
	<p>BY: KEVIN B 04/29/03 SHEET 7 OF 8</p>	

TABLE 9

FIRST END OPTION	FIRST END SUB-HQCD-X-XXX-XX-01	WIRING OPTION	FIRST END PIN #	SECOND END PIN #	WIRE #	SECOND END OPTION (SUB-HQCD-X-XXX-XX-XX)											
						-TTR	-TTL	-TBR	-TBL	-STR	-STL	-SBR	-SBL	-TEJ	-TED	-SEJ	-SED
						-TTR	-T-XXX-01-01	1	1	1	B30	-T-XXX-02-02	N/A	N/A	-T-XXX-01-02	N/A	-S-XXX-01-01

FOR RT1 OPTION SUB ASSEMBLY ADD -RT1 TO THE END OF THE SUB ASSEMBLY CALLOUT LISTED IN THE TABLE ABOVE.

PROPRIETARY NOTE

THIS DOCUMENT CONTAINS CONFIDENTIAL AND PROPRIETARY INFORMATION AND ALL DESIGN, MANUFACTURING, REPRODUCTION, USE, PATENT RIGHTS AND SALES RIGHTS ARE EXPRESSLY RESERVED BY SAMTEC, INC. THIS DOCUMENT SHALL NOT BE DISCLOSED, IN WHOLE OR PART, TO ANY UNAUTHORIZED PERSON OR ENTITY NOR REPRODUCED, TRANSFERRED OR INCORPORATED IN ANY OTHER PROJECT IN ANY MANNER WITHOUT THE EXPRESS WRITTEN CONSENT OF SAMTEC, INC.



520 PARK EAST BLVD, NEW ALBANY, IN 47150
 PHONE: 812-944-6733 FAX: 812-948-5047
 e-Mail: info@SAMTEC.com code: 55322

DO NOT SCALE DRAWING

DESCRIPTION:
 0.5mm HIGH-SPEED COAX CABLE ASSEMBLY

DWG. NO.
 HQCD-XXX-XX.XX-XXX-XXX-X-X

BY: KEVIN B 04/29/03 SHEET 8 OF 8

SHEET SCALE: 1.25:1