

STRAIGHT BULKHEAD JACK FULL CRIMP

R164.331.000

PANEL SEAL CABLE 10/50 S

Series : QN

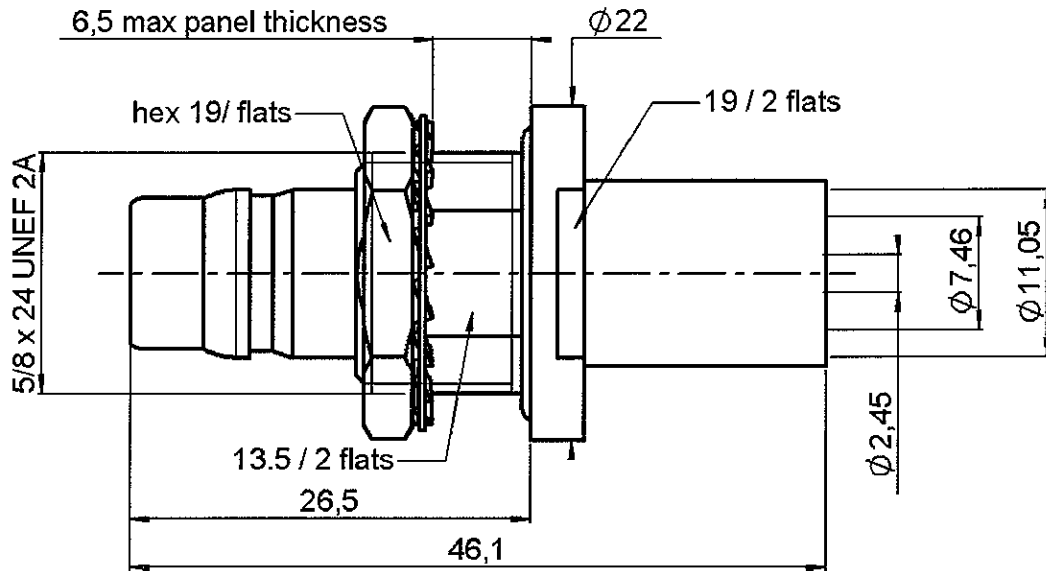

PANEL CUT OUT

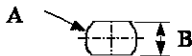

	mm	
	Maxi	mini
A	16.3	16
B	13.9	13.6

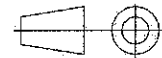
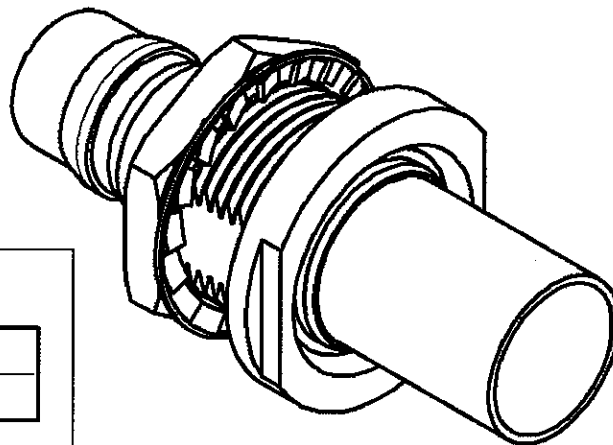
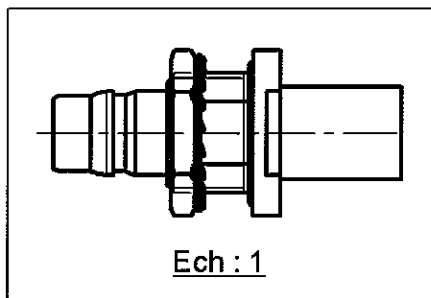

All dimensions are in mm.

COMPONENTS	MATERIALS	PLATINGS (µm)
BODY	BRASS	BBR-0.5 OVER SILVER 3
CENTER CONTACT	BERYLLIUM COPPER	SILVER 5 PASSIVATED OVER COPPER 0.5
OUTER CONTACT		
INSULATOR	PTFE	
GASKET	SILICONE RUBBER	
OTHERS PARTS	BRASS	BBR 2
-	-	
-	-	

Issue : 0505 B

In the effort to improve our products, we reserve the right to make changes judged to be necessary.



STRAIGHT BULKHEAD JACK FULL CRIMP

R164.331.000

PANEL SEAL CABLE 10/50 S

Series : QN

PACKAGING

Standard	Unit	Other
50	'W' option	Contact us

SPECIFICATION

ELECTRICAL CHARACTERISTICS

Impedance		50 Ω
Frequency		0-6* GHz
VSWR	1.05 +	0.025 x F(GHz) Maxi
Insertion loss		0.048 √F(GHz) dB Maxi
RF leakage	- (** - F(GHz)) dB Maxi
Voltage rating		1000 Veff Maxi
Dielectric withstanding voltage		2500 Veff mini
Insulation resistance		5000 MΩ mini

CABLE ASSEMBLY

Stripping	a	b	c	d	e	f
mm	5.00	8.00	14.0	0.00	9.00	0.00

Assembly instruction : **Crimp 02**

Recommended cable(s)
KX 4
RG 165
RG 213

Characteristics indicated on this data sheet are those that can be achieved with the highest performance cable. Intrinsic limitations of the cable may diminish the performance of the assembly

Cable retention

- pull off **300** N mini
- torque **NA** N.cm

MECHANICAL CHARACTERISTICS

Center contact retention		
Axial force – Mating end	68	N mini
Axial force – Opposite end	68	N mini
Torque	NA	N.cm mini

Recommended torque		
Mating	NA	N.cm
Panel nut	500	N.cm
Clamp nut	NA	N.cm
A/F clamp nut	19.000	mm

Mating life	100	Cycles mini
Weight	32.663	g

TOOLING

Part Number	Description	Hexagon
.	.	.
R282.231.000	CRIMPING TOOL	2.54-10.54
R282.235.116	CRIMPING DIES	2.54-10.54
R282.293.000	CRIMPING TOOL	

OTHERS CHARACTERISTICS

* usable 0-11GHz
** Connector only : -90dB DC<F<3GHz
-80dB min 3<F<6GHz

ENVIRONMENTAL

Operating temperature	-55/+125	°C
Hermetic seal	NA	Atm.cm3/s
Panel leakage	RUISS	

Issue : 0505 B

In the effort to improve our products, we reserve the right to make changes judged to be necessary.



Crimp 02 : Full crimp



A world of interconnect solutions

COMPONENTS

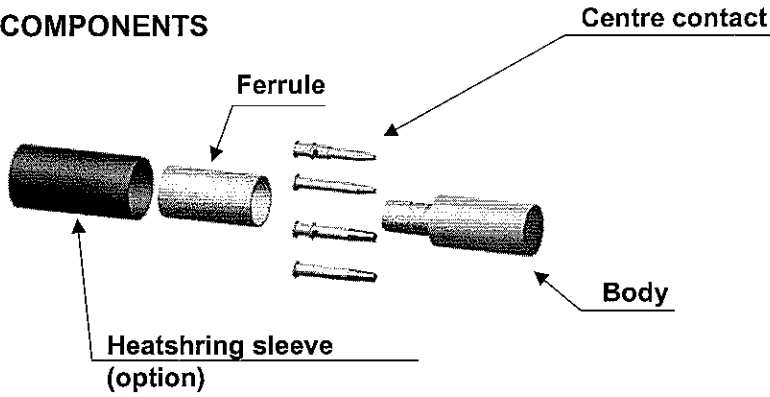

STRIPPING DIMENSIONS

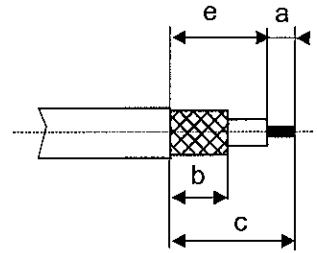

1
Slide the heatshrink sleeve onto the cable (Option).
Slide the ferrule onto the cable.
Strip the cable.

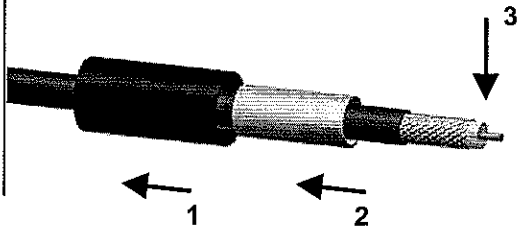

4
Slide the cable into the body until it bottoms against insulator.

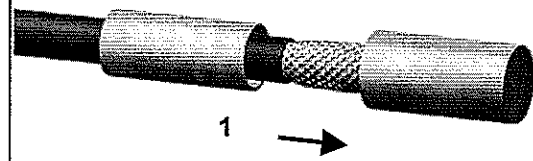

2
Slide the centre contact on until it bottoms against the cable dielectric.
Crimp the centre contact with crimping tool (see connector TDS).

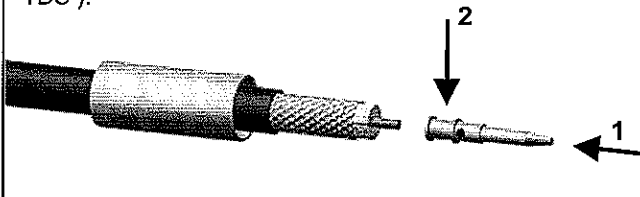

5
Slide the ferrule over the braid.
Crimp the ferrule with crimping tool (see connector TDS).

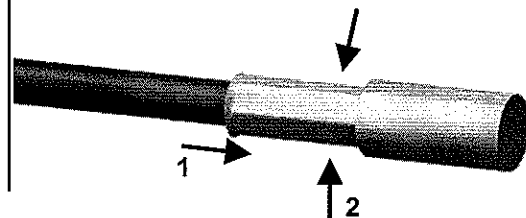

3
Fan the braid.

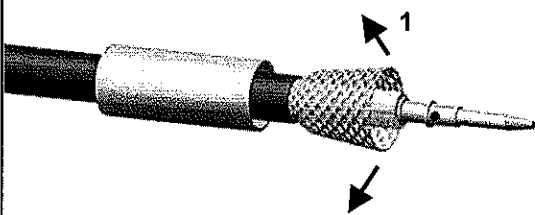

6
Cut the excess of braid if necessary.
Slide the sleeve over the ferrule and heatshrink it in place (Option).

