

Customer Information Sheet

DRAWING No.: H2088-01

IF IN DOUBT - ASK

©

NOT TO SCALE

THIRD ANGLE PROJECTION

ALL DIMENSIONS IN mm

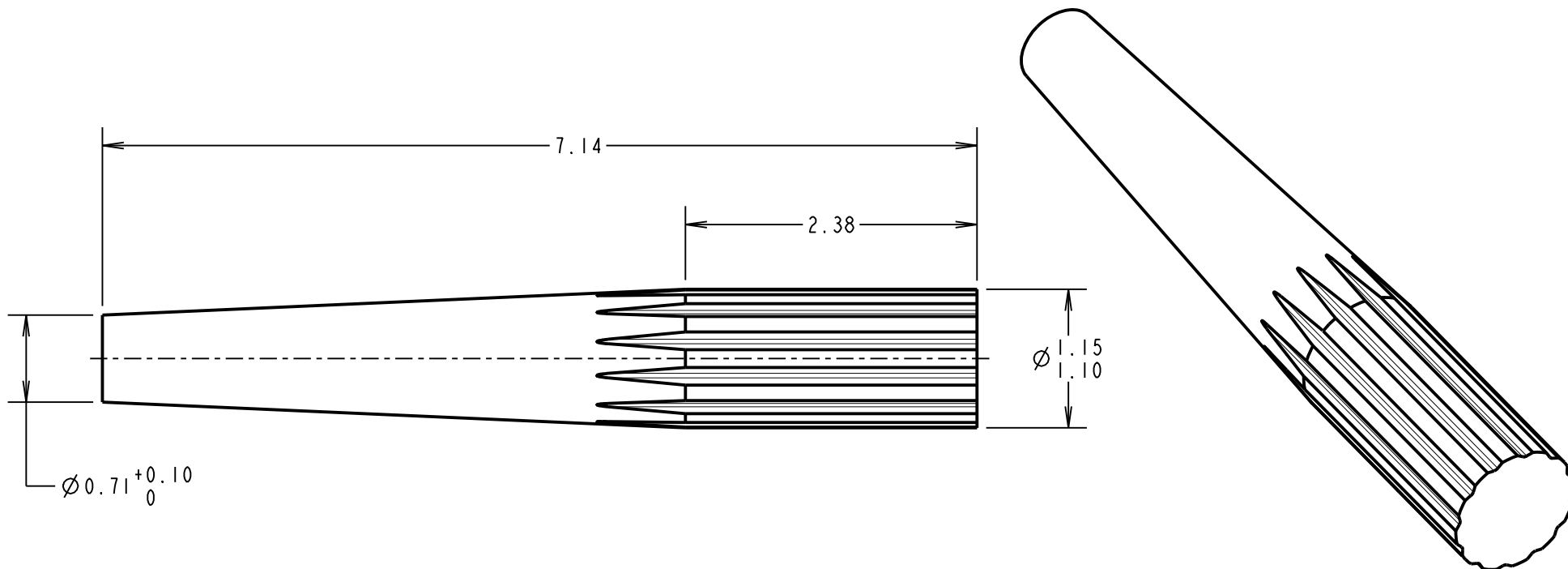

NOTES:

1. RECOMMENDED PANEL THICKNESS = 1.6/2.4mm.
2. RECOMMENDED MOUNTING HOLE SIZE FOR PAPER-BASED PANEL = $\varnothing 1.00$
RECOMMENDED MOUNTING HOLE SIZE FOR EPOXY-GLASS PANEL = $\varnothing 1.05$
3. PUNCH & DIE TOOL PART No. = Z2088-00

MGP	16	21.06.21	30602
NAME	ISS.	DATE	CN/CO
APPROVED: MGP			
CHECKED: RA			
DRAWN: PETER COLLINS			
CUSTOMER REF.:			
ASSEMBLY DRG:			

HARWIN

www.harwin.com
technical@harwin.com

THIS DRAWING AND ANY INFORMATION OR DESCRIPTIVE MATTER SET OUT HEREON ARE CONFIDENTIAL AND COPYRIGHT PROPERTY OF THE HARWIN GROUP AND MUST NOT BE DISCLOSED, LOANED, COPIED OR USED FOR MANUFACTURING, TENDERING OR FOR ANY OTHER PURPOSE WITHOUT THEIR WRITTEN PERMISSION.

TOLERANCES
 X. = ± 1 mm
 X.X = ± 0.50 mm
 X.XX = ± 0.20 mm
 X.XXX = ± 0.01 mm
 ANGLES = $\pm 5^\circ$
 UNLESS STATED

MATERIAL:
 BRASS CW614N M
 TO BS EN 12164 (CuZn39Pb3)
FINISH: 100% TIN OVER NICKEL
S/AREA: mm²

TITLE:
 TERMINAL PIN
DRAWING NUMBER:
 H2088-01

SHT
2 OF 2