

XS/SC26 and SC10-2 Safety Controllers

Instruction Manual

Original Instructions
174868 Rev. X
7 February 2023
© Banner Engineering Corp. All rights reserved



174868

Contents

1 About This Document	6
1.1 Important... Read This Before Proceeding!	6
1.2 Use of Warnings and Cautions	6
1.3 EU/UK Declaration of Conformity (DoC)	6
2 Product Description	8
2.1 Terms Used in this Manual	8
2.2 Software	8
2.3 USB Connections	8
2.4 Ethernet Connections	9
2.5 Internal Logic	9
2.6 Password Overview	9
2.7 SC-XM2/3 Drive and SC-XMP2 Programming Tool	10
3 XS/SC26 Overview	11
3.1 XS/SC26 Models	11
3.2 XS/SC26 Features and Indicators	12
3.3 Using XS/SC26 Safety Controllers with Different FIDs	12
3.4 Input and Output Connections	13
3.4.1 XS/SC26 Safety and Non-Safety Input Devices	13
3.4.2 XS/SC26 Safety Outputs	13
3.4.3 XS/SC26 Status Outputs and Virtual Status Outputs	14
3.5 XS/SC26 Automatic Terminal Optimization (ATO) Feature	15
4 SC10-2 Overview	17
4.1 SC10-2 Models	17
4.2 SC10-2 Features and Indicators	17
4.3 Using SC10-2 Safety Controllers with Different FIDs	18
4.4 Input and Output Connections	19
4.4.1 SC10-2 Safety and Non-Safety Input Devices	19
4.4.2 SC10-2 Safety Relay Outputs	19
4.4.3 SC10-2 Status Outputs and Virtual Status Outputs	19
4.5 SC10-2 Automatic Terminal Optimization (ATO) Feature with External Terminal Blocks (ETB)	19
5 Specifications and Requirements	20
5.1 XS/SC26 Specifications	20
5.2 SC10-2 Specifications	24
5.3 Dimensions	27
5.4 PC Requirements	27
6 System Installation	29
6.1 Installing the Software	29
6.2 Installing the Safety Controller	29
6.2.1 Mounting Instructions	29
7 Installation Considerations	30
7.1 Appropriate Application	30
7.2 XS/SC26 Applications	30
7.3 SC10-2 Applications	31
7.4 Safety Input Devices	31
7.4.1 Safety Circuit Integrity and ISO 13849-1 Safety Circuit Principles	32
7.4.2 Safety Input Device Properties	34
7.5 Safety Input Device Options	36
7.5.1 Safety Circuit Integrity Levels	37
7.5.2 Emergency Stop Push Buttons	37
7.5.3 Rope (Cable) Pull	38
7.5.4 Enabling Device	39
7.5.5 Protective (Safety) Stop	39
7.5.6 Interlocked Guard or Gate	39
7.5.7 Optical Sensor	40
7.5.8 Two-Hand Control	40
7.5.9 Safety Mat	43
7.5.10 Muting Sensor	46
7.5.11 Bypass Switch	47
7.5.12 Adjustable Valve Monitoring (AVM) Function	48
7.5.13 ISD Inputs	49
7.5.14 Cycle Initiation for Press Control Function Block	55
7.5.15 Press Control Sequential Stop (SQS) Function	55
7.5.16 Press Control Mute Sensor	56

7.5.17 Foot Switch	57
7.6 Non-Safety Input Devices	58
7.6.1 Manual Reset Input	59
7.7 Virtual Non-Safety Input Devices	60
7.7.1 Virtual Manual Reset and Cancel Delay (RCD) Sequence	61
7.7.2 Virtual ON/OFF and Mute Enable	63
7.8 Safety Outputs	64
7.8.1 Solid-State Safety Outputs	66
7.8.2 Safety Relay Outputs	69
7.8.3 EDM and FSD Wiring	70
7.9 Status Outputs	78
7.9.1 Status Output Signal Conventions	78
7.9.2 Status Output Functionality	79
7.9.3 Press Control Status Output Functionality	80
7.10 Virtual Status Outputs	81
8 Getting Started	83
8.1 Creating a Configuration	83
8.2 Adding Inputs and Status Outputs	83
8.2.1 Adding Safety and Non-Safety Inputs	83
8.2.2 Adding Status Outputs	87
8.3 Designing the Control Logic	88
8.4 Saving and Confirming a Configuration	89
8.4.1 Saving a Configuration	89
8.4.2 Confirming a Configuration	89
8.4.3 Write a Confirmed Configuration to an SC-XM2/3 using the Programming Tool	91
8.4.4 Notes on Confirming or Writing a Configuration to a Configured SC10-2 or XS/SC26 FID 3 or later	91
8.5 Sample Configurations	92
8.5.1 XS/SC26 Sample Configuration	92
8.5.2 XS/SC26: Simple Press Control with Mutable Safety Input Sample Configuration	94
8.5.3 XS/SC26: Full Feature Press Control Sample Configuration	97
9 Software	101
9.1 Abbreviations	101
9.2 Software Overview	103
9.3 New Project	105
9.4 Project Settings	105
9.5 Equipment Tab	106
9.6 Functional View Tab	107
9.6.1 Logic Blocks	108
9.6.2 Function Blocks	110
9.7 Wiring Diagram Tab	111
9.8 Ladder Logic Tab	113
9.9 ISD Tab	113
9.10 Industrial Ethernet Tab	117
9.10.1 Network Settings	120
9.10.2 PLC Tags/Labels File Creation	122
9.10.3 EtherNet/IP Assembly Objects	122
9.11 Configuration Summary Tab	123
9.12 Print Options	124
9.13 XS/SC26 Password Manager	125
9.14 SC10-2 Password Manager	126
9.15 Viewing and Importing Controller Data	126
9.16 Live Mode	128
9.17 Simulation Mode	131
9.17.1 Timed Action Mode	134
9.18 Reference Signals	135
10 Function Block Descriptions	136
10.1 Bypass Block	136
10.1.1 Lockout/Tagout	136
10.2 Delay Block	137
10.3 Enabling Device Block	138
10.4 Latch Reset Block	139
10.5 Muting Block	143
10.5.1 Optional Muting Attributes	149
10.6 One Shot Block	151
10.7 Press Control	153
10.7.1 Mode Function Block	154
10.7.2 Press Control Inputs Function Block	155
10.7.3 Press Control Function Block Examples	156
10.7.4 Closed Loop Control	158
10.8 Two-Hand Control Block (For XS/SC26 FID 3 and older and SC10-2 FID 1)	159

10.9 Two-Hand Control Block (XS/SC26 FID 4 and later and SC10-2 FID 2 and later)	162
11 XS/SC26 Onboard Interface	163
11.1 XS/SC26 Configuration Mode	164
12 Industrial Ethernet Overview	166
12.1 Configuring the Safety Controller	166
12.1.1 ClickSet IP Process	167
12.2 Industrial Ethernet Definitions	168
12.3 Retrieving Current Fault Information	170
12.4 EtherNet/IP™	170
12.4.1 L5X File Connection	170
12.4.2 EDS File Connection	174
12.4.3 Generic Ethernet Module Connection	183
12.4.4 Inputs to the Safety Controller (Outputs from the PLC)	189
12.4.5 Outputs from the Safety Controller (Inputs to the PLC)	191
12.4.6 Configuration Assembly Object	203
12.4.7 Fault Examples	204
12.4.8 Flags	205
12.4.9 Extended Flags	206
12.4.10 ISD System Status Words	206
12.4.11 RSLogix5000 Configuration (Explicit Messaging)	207
12.4.12 EIP on Omron PLC Configuration	217
12.5 Modbus® TCP	230
12.5.1 Input and Coil Bits	230
12.5.2 Input and Holding Registers	231
12.6 PLC5, SLC500, and MicroLogix (PCCC)	244
12.6.1 PLC Configuration	245
12.6.2 Outputs from Safety Controller (Inputs to PLC)	246
12.6.3 Inputs to Safety Controller (Outputs from PLC)	258
12.6.4 Flags	258
12.6.5 Extended Flags	259
12.7 PROFINET®	259
12.7.1 PROFINET® and the Safety Controllers	260
12.7.2 General Station Description (GSD) File	260
12.7.3 PROFINET® IO Data Model	260
12.7.4 Configuring the Safety Controller for a PROFINET IO Connection	260
12.7.5 Create a XML File For PROFINET	260
12.7.6 Description of Modules	262
12.7.7 Configuration Instructions	273
12.8 EtherCAT®	286
12.8.1 EtherCAT® and the Safety Controllers	286
12.8.2 EtherCAT® Slave Information (ESI) File	286
12.8.3 EtherCAT® IO Data Model	287
12.8.4 Configuring the Safety Controller for EtherCAT® IO Connection	287
12.8.5 Create a PLCopenXML for EtherCAT® for TwinCAT® 3.0	287
12.8.6 Description of Process Data Objects	288
12.8.7 Configuration Instructions	294
12.8.8 EtherCAT® PDO Modification	295
12.9 ISD: Additional Information	296
12.9.1 ISD: Temperature, Voltage, and Distance Conversion Information	296
13 System Checkout	299
13.1 Schedule of Required Checkouts	299
13.2 Commissioning Checkout Procedure	299
13.2.1 Verifying System Operation	300
13.2.2 Initial Setup, Commissioning, and Periodic Checkout Procedures	300
14 Status and Operating Information	307
14.1 XS/SC26 LED Status	307
14.2 Input Module Status Indicators	308
14.3 Output Module (Solid-State or Relay) Status Indicators	309
14.4 EtherCAT® Communication Gateway Module Status Indicators	309
14.5 SC10-2 LED Status	310
14.6 Live Mode Information: Software	312
14.7 Live Mode Information: Onboard Interface	312
14.8 Lockout Conditions	312
14.9 Recovering from a Lockout	313
14.10 AutoDetect ISD Option	313
14.11 SC10-2 Using Automatic Terminal Optimization	315
14.12 SC10-2 Example Configuration without Automatic Terminal Optimization	317
14.13 XS/SC26 Models without an Onboard Interface: Using the SC-XM2/3	321
14.14 XS/SC26 Models with an Onboard Interface: Using the SC-XM2/3	322
14.14.1 XS/SC26 FID 1 or FID 2 Controllers with an Onboard Interface: Using the SC-XM2/3	323

- 14.14.2 XS/SC26 FID 3 and Later Controllers with an Onboard Interface: Using the SC-XM2/3 324
- 14.15 SC10-2: Using the SC-XM3 328
- 14.16 Reset the Safety Controller to Factory Defaults 328
- 14.17 Factory Defaults 329
- 15 Troubleshooting 330**
- 15.1 Software: Troubleshooting 330
- 15.2 Software: Error Codes 331
- 15.3 Verifying Driver Installation 333
- 15.4 Finding and Fixing Faults 334
- 15.4.1 XS/SC26 Fault Code Table 335
- 15.4.2 SC10-2 Fault Code Table 340
- 16 Components and Accessories 343**
- 16.1 Replacement Parts and Accessories 343
- 16.2 Ethernet Cordsets 343
- 16.3 Interface Modules 343
- 16.3.1 Mechanically Linked Contactors 343
- 17 Product Support and Maintenance 344**
- 17.1 Cleaning 344
- 17.2 Repairs and Warranty Service 344
- 17.3 Contact Us 344
- 17.4 Banner Engineering Corp. Limited Warranty 344
- 17.5 Banner Engineering Corp. Software Copyright Notice 344
- 18 Standards and Regulations 345**
- 18.1 Applicable U.S. Standards 345
- 18.2 Applicable OSHA Regulations 345
- 18.3 Applicable European and International Standards 345
- 19 Glossary 347**

1 About This Document

1.1 Important... Read This Before Proceeding!

It is the responsibility of the machine designer, controls engineer, machine builder, machine operator, and/or maintenance personnel or electrician to apply and maintain this device in full compliance with all applicable regulations and standards. The device can provide the required safeguarding function only if it is properly installed, properly operated, and properly maintained. This manual attempts to provide complete installation, operation, and maintenance instruction. *Reading the manual in its entirety is highly recommended to ensure proper understanding of the operation, installation, and maintenance.* Please direct any questions regarding the application or use of the device to Banner Engineering.

For more information regarding U.S. and international institutions that provide safeguarding application and safeguarding device performance standards, see [Standards and Regulations](#) on page 345.







WARNING:

- The user is responsible for following these instructions.
- **Failure to follow any of these responsibilities may potentially create a dangerous condition that could result in serious injury or death.**
- Carefully read, understand, and comply with all instructions for this device.
- Perform a risk assessment that includes the specific machine guarding application. Guidance on a compliant methodology can be found in ISO 12100 or ANSI B11.0.
- Determine what safeguarding devices and methods are appropriate per the results of the risk assessment and implement per all applicable local, state, and national codes and regulations. See ISO 13849-1, ANSI B11.19, and/or other appropriate standards.
- Verify that the entire safeguarding system (including input devices, control systems, and output devices) is properly configured and installed, operational, and working as intended for the application.
- Periodically re-verify, as needed, that the entire safeguarding system is working as intended for the application.

1.2 Use of Warnings and Cautions

The precautions and statements used throughout this document are indicated by alert symbols and must be followed for the safe use of the Banner Safety Controller. Failure to follow all precautions and alerts may result in unsafe use or operation. The following signal words and alert symbols are defined as follows:

Signal Word	Definition	Symbol
 WARNING:	Warnings refer to potentially hazardous situations which, if not avoided, could result in serious injury or death.	
 CAUTION:	Cautions refer to potentially hazardous situations which, if not avoided, could result in minor or moderate injury.	

These statements are intended to inform the machine designer and manufacturer, the end user, and maintenance personnel, how to avoid misapplication and effectively apply the Banner Safety Controller to meet the various safeguarding application requirements. These individuals are responsible to read and abide by these statements.

1.3 EU/UK Declaration of Conformity (DoC)

Banner Engineering Corp. herewith declares that these products are in conformity with the provisions of the listed directives, regulations, and all essential health and safety requirements have been met. For the complete DoC, please go to www.bannerengineering.com.

Product	Directive
SC26-2 Programmable Safety Controller, XS26-2 Programmable Safety Controller, XS26-ISD Programmable Safety Controller, XS2so and XS4so Solid-State Safety Output Modules, XS8si and XS16si Safety Input Modules, XS1ro and XS2ro Safety Relay Modules, XSeCAT EtherCAT Communication Gateway Module, and SC10-2 Safety Controller	EU: Machine Safety Directive 2006/42/EC and EMC Directive 2004/108/EC UK: Machinery (Safety) Regulations 2008 and EMC Regulations 2016

Representative in EU: Spiros Lachandidis, Managing Director, **Banner Engineering BV** Park Lane, Culliganlaan 2F bus 3, 1831 Diegem, BELGIUM

Representative in UK: Tony Coghlan, Managing Director, **Turck Banner LTD** Blenheim House, Blenheim Court, Wickford, Essex SS11 8YT, Great Britain

2 Product Description

Safety control is a critical and required part of any safety system. This is because safety controllers ensure that your safety measures 1) do not fail, or 2) if failure is inevitable, fail in a predictable safe way.

A safety controller is often an ideal safety control solution, because it provides more functionality than a safety relay, at a lower cost than a safety PLC. In addition, a smart, scalable safety controller can expand with your needs as well as enable remote monitoring of your machine safety systems.

Banner Engineering Safety Controllers are easy-to-use, configurable, and expandable modules (XS26 models) designed to monitor multiple safety and non-safety input devices, providing safe stop and start functions for machines with hazardous motion. The Safety Controller can replace multiple safety relay modules in applications that include such safety input devices as E-stop buttons, interlocking gate switches, safety light curtains, two-hand controls, safety mats, and other safeguarding devices. The Safety Controller may also be used in place of larger and more complex safety PLCs with the use of additional input and/or output expansion modules.

The onboard interface:

- Provides access to fault diagnostics
- Allows reading and writing the configuration file from and to the SC-XM2 and SC-XM3 drives
- XS/SC26: Displays configuration summary, including terminal assignments and network settings

2.1 Terms Used in this Manual

The following terms are used in this manual.

Safety Controller—an abbreviated version referring to the entire XS/SC26 Safety Controller system, as well as to the SC10-2, both of which are covered by this manual

Expandable Safety Controller—refers to expandable models

Base Controller—refers to the main module in the XS/SC26 Safety Controller System

SC26-2 Programmable Safety Controller, XS26-2 Programmable Safety Controller, XS26-ISD Programmable Safety Controller, XS2so and XS4so Solid-State Safety Output Modules, XS8si and XS16si Safety Input Modules, XS1ro and XS2ro Safety Relay Modules, XSeCAT EtherCAT Communications Gateway Module—formal name of the XS/SC26 product line

2.2 Software

The Banner Safety Controller Software is an application with real-time display and diagnostic tools that are used to:

- Design and edit configurations
- Test a configuration in Simulation Mode
- Write a configuration to the Safety Controller
- Read the current configuration from the Safety Controller
- Display real-time information, such as device statuses
- Display fault information

The Software uses icons and circuit symbols to assist in making appropriate input device and property selections. As the various device properties and I/O control relationships are established on the **Functional View** tab, the program automatically builds the corresponding wiring and ladder logic diagrams.

See [Software Overview](#) on page 103 for details.

2.3 USB Connections

The micro USB port on the Base Controller and the SC10-2 is used to connect to a PC (via the SC-USB2 cable) and the SC-XM2/3 drive to read and write configurations created with the Software.

**CAUTION:**

- **Potential for Unintended Ground Return Path**
- A large current could damage the PC and/or the Safety Controller.
- The USB interface is implemented in an industry standard way and is not isolated from the 24 V return path.
- The USB cable makes it possible for the computer and Safety Controller to become part of an unintended ground return path for other connected equipment. A large current could damage the PC and/or the Safety Controller. To minimize this possibility, Banner Engineering recommends that the USB cable is the only cable connected to the PC and the PC is placed on a non-conducting surface. This includes disconnecting the AC power supply from a laptop whenever possible.
- The USB interface is intended for downloading configurations and temporary monitoring or troubleshooting. It is not designed for continuous use as a maintenance port.

2.4 Ethernet Connections

Ethernet connections are made using an Ethernet cable connected from the Ethernet port of the Base Safety Controller (Ethernet-enabled models only), dual ports of the XSeCAT communication gateway, or SC10-2 to a network switch or to the control or monitoring device. The Safety Controller supports either the standard or crossover-style cables. A shielded cable may be needed in high-noise environments.



Note: The Ethernet cable bringing communications to the XSeCAT communications gateway (that is, from the PLC, upstream) must be connected to ECAT IN on the top of the module. The Ethernet cable taking communications away from the XSeCAT communications gateway (that is, to the PLC, upstream) must be connected to ECAT OUT on the bottom of the module.

2.5 Internal Logic

The Safety Controller's internal logic is designed so that a Safety Output can turn On only if all the controlling safety input device signals and the Safety Controller's self-check signals are in the Run state and report that there is no fault condition.

The Banner Safety Controller Software uses both Logic and Safety Function blocks for simple and more advanced applications.



Logic Blocks are based on Boolean (True or False) logic laws. The following Logic Blocks are available:

- NOT
- AND
- OR
- NAND
- NOR
- XOR
- Flip Flop (Set priority and Reset priority)

See [Logic Blocks](#) on page 108 for more information.



Function Blocks are pre-programmed blocks with built-in logic which provide various attribute selections to serve both common and complex application needs. The following Function Blocks are available:

- Bypass Block
- Delay Block (XS/SC26 FID 2 or later and SC10-2)
- Enabling Device Block
- Latch Reset Block
- Muting Block
- THC (Two-Hand Control) Block
- One Shot Block (XS/SC26 FID 4 or later)
- Press Control Block (XS/SC26 FID 4 or later)

See [Function Blocks](#) on page 110 for more information.

2.6 Password Overview

A password is required to confirm and write the configuration to the Safety Controller and to access the Password Manager via the Software. See [XS/SC26 Password Manager](#) on page 125 and [SC10-2 Password Manager](#) on page 126 for more information.

2.7 SC-XM2/3 Drive and SC-XMP2 Programming Tool

Use the SC-XM2 and SC-XM3 drives to store a **confirmed** configuration.

XS/SC26: The configuration can be written directly by the Safety Controller, when the drive is plugged into the micro-USB port (see [XS/SC26 Configuration Mode](#) on page 164), or via the SC-XMP2 Programming Tool using only the Software without the need to plug in the Safety Controller.



Important: Verify that the configuration that is being imported to the Safety Controller is the correct configuration (via the Software or writing on the white label on the SC-XM2/3 drive).

Click  to access the programming tool options:

- **Read**—reads the current Safety Controller configuration from the SC-XM2/3 drive and loads it to the Software
- **Write**—writes a confirmed configuration from the Software to the SC-XM2/3 drive
- **Lock**—locks the SC-XM2/3 drive preventing any configurations from being written to it (an empty drive cannot be locked)



Note: You will not be able to unlock the SC-XM2/3 drive after it has been locked.

3 XS/SC26 Overview

With the option to add up to eight I/O expansion modules, the XS26 Expandable Safety Controller has the capacity to adapt to a variety of machines, including large scale machines with multiple processes.

Figure 1. XS/SC26 Safety Controller



- Program in minutes with intuitive, easy-to-use configuration software
- Up to eight expansion I/O modules can be added as automation requirements grow or change
- Choose from six expansion module models
- Expansion module models have a variety of safety inputs, solid-state safety outputs and safety relay outputs
- Innovative live display feature and diagnostics allow for active monitoring of I/O on a PC and assist in troubleshooting and commissioning
- Safety Controller and input modules allow safety inputs to be converted to status outputs for efficient terminal use
- Ethernet-enabled models can be configured for up to 256 virtual status outputs
- Optional SC-XM2/3 external drive for fast swap and quick configuration without a PC
- In-Series Diagnostic (ISD) provides detailed status and performance data from each connected safety device which can be accessed with an HMI or similar device (XS26-ISD models only)

3.1 XS/SC26 Models

All Expandable and Non-Expandable Base controllers have 18 Safety Inputs, 8 Convertible Safety I/Os, and 2 Solid-State Safety Output pairs. Up to eight expansion modules, in any combination of input and output modules, can be added to the expandable models of the Base Controller. One communication gateway can be added to FID 6 and later expandable, Ethernet-enabled models of Base Controller.

Table 1: Expandable Base Models

Model	Display	Ethernet-enabled	# of ISD Channels
XS26-2	No	No	0
XS26-2d	Yes	No	0
XS26-2e	No	Yes	0
XS26-2de	Yes	Yes	0
XS26-ISDd	Yes	Yes	8

Table 2: Non-Expandable Base Models

Model	Display	Ethernet-enabled	# of ISD Channels
SC26-2	No	No	0
SC26-2d	Yes	No	0
SC26-2e	No	Yes	0
SC26-2de	Yes	Yes	0

Table 3: I/O Expansion Modules

Model	Description
XS16si	Safety Input Module - 16 inputs (4 convertible)
XS8si	Safety Input Module - 8 inputs (2 convertible)
XS2so	2 Dual Channel Solid-State Safety Output Module
XS4so	4 Dual Channel Solid-State Safety Output Module
XS1ro	1 Dual Channel Safety Relay Module

Model	Description
XS2ro	2 Dual Channel Safety Relay Module
XSeCAT	EtherCAT Communication Gateway

3.2 XS/SC26 Features and Indicators

Figure 2. XS/SC26 Features and Indicators

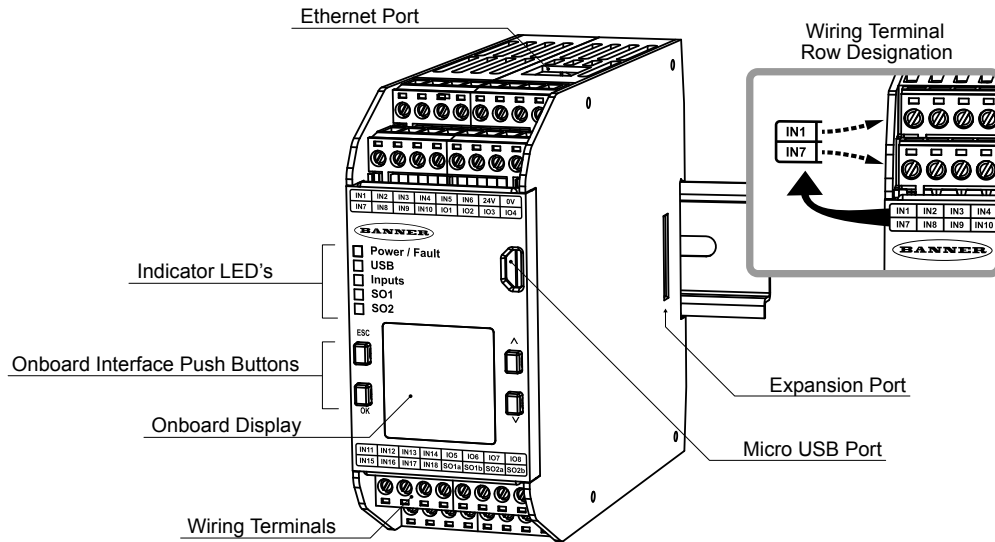

3.3 Using XS/SC26 Safety Controllers with Different FIDs

Over time, Banner adds new features to some devices. The Feature ID (FID) identifies the set of features and functions included in a particular model. Generally, an increasing FID number corresponds to an increasing feature set. A configuration using a higher numbered FID feature is not supported by a Safety Controller of a lower FID. Feature sets are forward compatible, not backwards compatible.

XS/SC26 Base Controllers that have different FIDs, can be used in the same application, however steps must be taken to ensure compatibility. See the side label on the module (Figure 3 on page 12) or query the Module Information of the Base Controller to determine the FID of a particular device. In order to have one configuration file that applies to a device of any FID, create configurations without using the features listed in the following table. Confirm all configurations after loading to ensure that they are correct.

Figure 3. Example Label

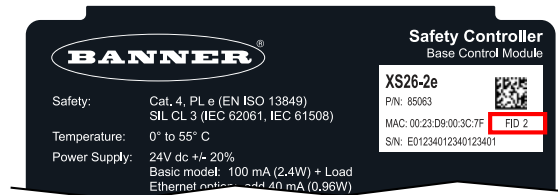

Table 4: FID Descriptions

FID Number	Added Feature Set
FID 1	Initial feature set
FID 2	PROFINET®, virtual non-safety inputs, delay blocks, Track Function Block status output and an increase from 64 to 256 virtual status outputs
FID 3	Factory Default functionality, SC-XM3 transfer

FID Number	Added Feature Set
FID 4	Hydraulic/Pneumatic Press Control block, the ability to perform OR logic on reset inputs, One Shot timing block, and setting a physical status output to cycle on and off
FID 5	Released XS26-ISD models, which added the ability to directly convert In-Series Diagnostic Information from 8 ISD chains to USB (using the Software) and Industrial Ethernet protocols
FID 6	Released XSeCAT Communication Gateway for use with EtherCAT® communications.

The checklist in the Banner Safety Controller Software shows a warning when a feature is added that requires a Safety Controller with firmware other than an FID 1 Safety Controller.

Figure 4. Example Checklist Warning

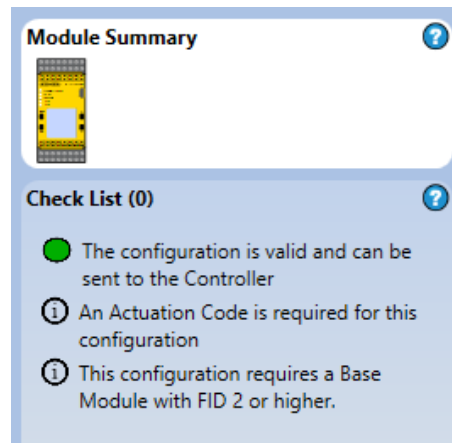

Note: Expansion modules are FID 1. They can run most functionality because the functionality is controlled by the Base Controller.

3.4 Input and Output Connections

3.4.1 XS/SC26 Safety and Non-Safety Input Devices

The Base Controller has 26 input terminals that can be used to monitor either safety or non-safety devices; these devices may incorporate either solid-state or contact-based outputs. Some of the input terminals can be configured to either source 24 V DC for monitoring contacts or to signal the status of an input or an output. The function of each input circuit depends on the type of the device connected; this function is established during the controller configuration.

The FID 2 and later Base Controller also supports non-safety virtual inputs.

Some of the input terminals on the XS26-ISD models can be configured to monitor a chain of ISD enabled devices; this functionality is established during the controller configuration.

The expansion modules XS8si and XS16si add additional inputs to the Safety Controller System.

Contact Banner Engineering for additional information about connecting other devices not described in this manual.

3.4.2 XS/SC26 Safety Outputs

The Safety Outputs are designed to control Final Switching Devices (FSDs) and Machine Primary Control Elements (MPCEs) that are the last elements (in time) to control the dangerous motion. These control elements include relays, contactors, solenoid valves, motor controls, and other devices that typically incorporate force-guided (mechanically-linked) monitoring contacts, or electrical signals needed for external device monitoring (EDM).

The Safety Controller has two independently controlled and redundant solid-state Safety Outputs (terminals SO1a & SO1b, and SO2a & SO2b). The Safety Controller's self-checking algorithm ensures that the outputs turn On and Off at the appropriate times, in response to the assigned input signals.

Each redundant solid-state Safety Output is designed to work either in pairs or as two individual outputs. When controlled in pairs, the Safety Outputs are suitable for Category 4 applications; when acting independently, they are suitable for applications up to Category 3 when appropriate fault exclusion has been employed (see [Single-channel Control](#) in [Safety \(Protective\) Stop Circuits](#) on page 73 and [Safety Circuit Integrity and ISO 13849-1 Safety Circuit Principles](#) on page 32).

See [Safety Outputs](#) on page 64 for more information about hookup, solid-state and safety relay outputs, external device monitoring, single/dual-channel Safety Stop Circuits, and configuring Safety Outputs.

Additional solid-state or safety relay outputs can be added to expandable models (XS26) of the Base Controller by incorporating expansion output modules (XS2so, XS4so, XS1ro, and XS2ro). Up to eight expansion modules, in any combination of input or output modules, can be added.

The Safety Outputs can be controlled by input devices with both automatic and manual reset operation.

Figure 5. Safety Outputs (Example Application)

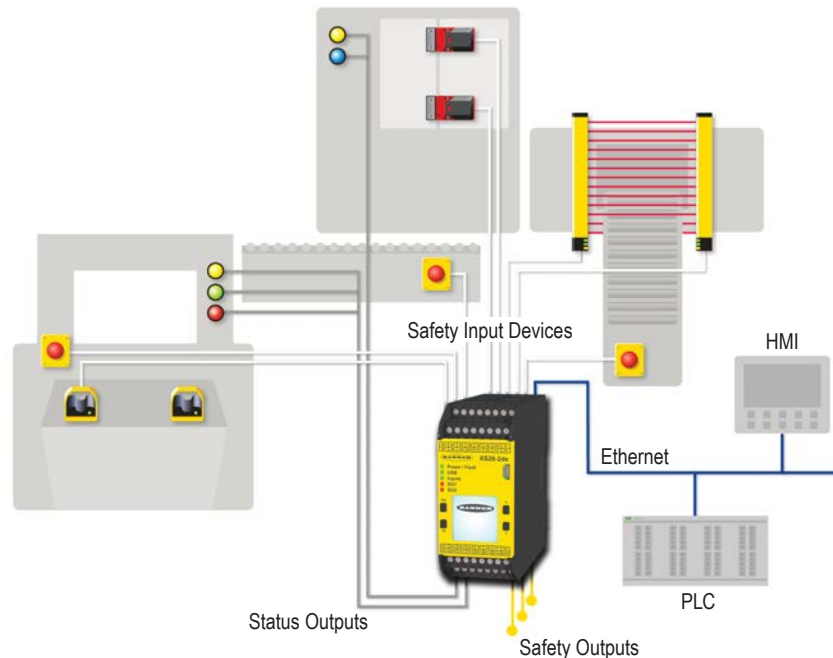

Functional Stops according to IEC 60204-1 and NFPA 79

The Safety Controller is capable of performing two functional stop types:

- Category 0: an uncontrolled stop with the immediate removal of power from the guarded machine
- Category 1: a controlled stop with a delay before power is removed from the guarded machine

Delayed stops can be used in applications where machines need power for a braking mechanism to stop the hazardous motion.

3.4.3 XS/SC26 Status Outputs and Virtual Status Outputs

The Base Controller has eight convertible I/Os (labeled **IOx**) that can be used as Status Outputs which have the capability to send non-safety status signals to devices such as programmable logic controllers (PLCs) or indicator lights. In addition, any unused Safety Output terminals may be configured to perform a Status Output function with the benefit of higher current capacity (see [XS/SC26 Specifications](#) on page 20 for more information). For the solid-state safety outputs configured as status outputs, the safety test pulses stay enabled even when designated as a status output. The Status Output signal convention can be configured to be 24 V DC, 0 V DC, or cycling on and off. See [Status Output Signal Conventions](#) on page 78 for information on the specific functions of a Status Output.

Ethernet models, using the Software, can be configured for up to 64 Virtual Status Outputs on FID 1 XS/SC26 Safety Controllers and up to 256 virtual status outputs on FID 2 and later XS/SC26 Safety Controllers. These outputs can communicate the same information as the status outputs over the network. See [Virtual Status Outputs](#) on page 81 for more information.



WARNING:

- **Status Outputs and Virtual Status Outputs are not safety outputs and can fail in either the On or the Off state.**
- If a Status Output or a Virtual Status Output is used to control a safety-critical application, a failure to danger is possible and may lead to serious injury or death.
- Never use a Status Output or Virtual Status Output to control any safety-critical applications.

3.5 XS/SC26 Automatic Terminal Optimization (ATO) Feature

Automatic Terminal Optimization (ATO) is a standard feature on all XS/SC26 models. This feature automatically combines up to two I/O terminals for two devices that require +24 V test pulses from the Safety Controller. When applicable, the Software automatically does this for every pair of devices that are added, until I/O terminals are no longer available. Sharing is limited to two because the screw-type terminals are capable of accepting up to two wires.

If preferred, terminals may be manually reassigned in the device **Properties** window.

The following figures illustrate the XS/SC26 ATO feature optimizing terminals for two gate switches. This results in a total terminal usage of six, versus eight if ATO is not utilized. The first gate switch (GS1) is added. This is a dual-channel, four-wire gate switch that requires two independent +24 V pulsed outputs from the Safety Controller. IO1 is assigned as +24 V test pulse 1 which runs through channel 1 of GS1 to IN1. IO2 is assigned as +24 V test pulse 2 which runs through channel 2 of GS1 to IN2. When the second gate switch GS2 is added, it also uses IO1 and IO2 but uses IN3 and IN4 to monitor its two channels.

Figure 6. GS1 and GS2 Sharing IO1 and IO2

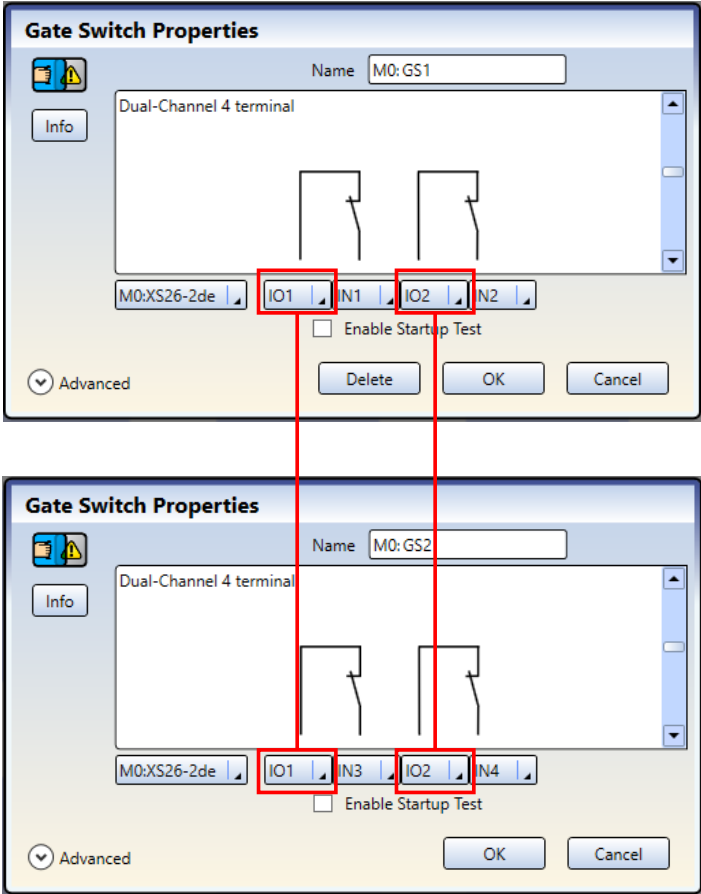
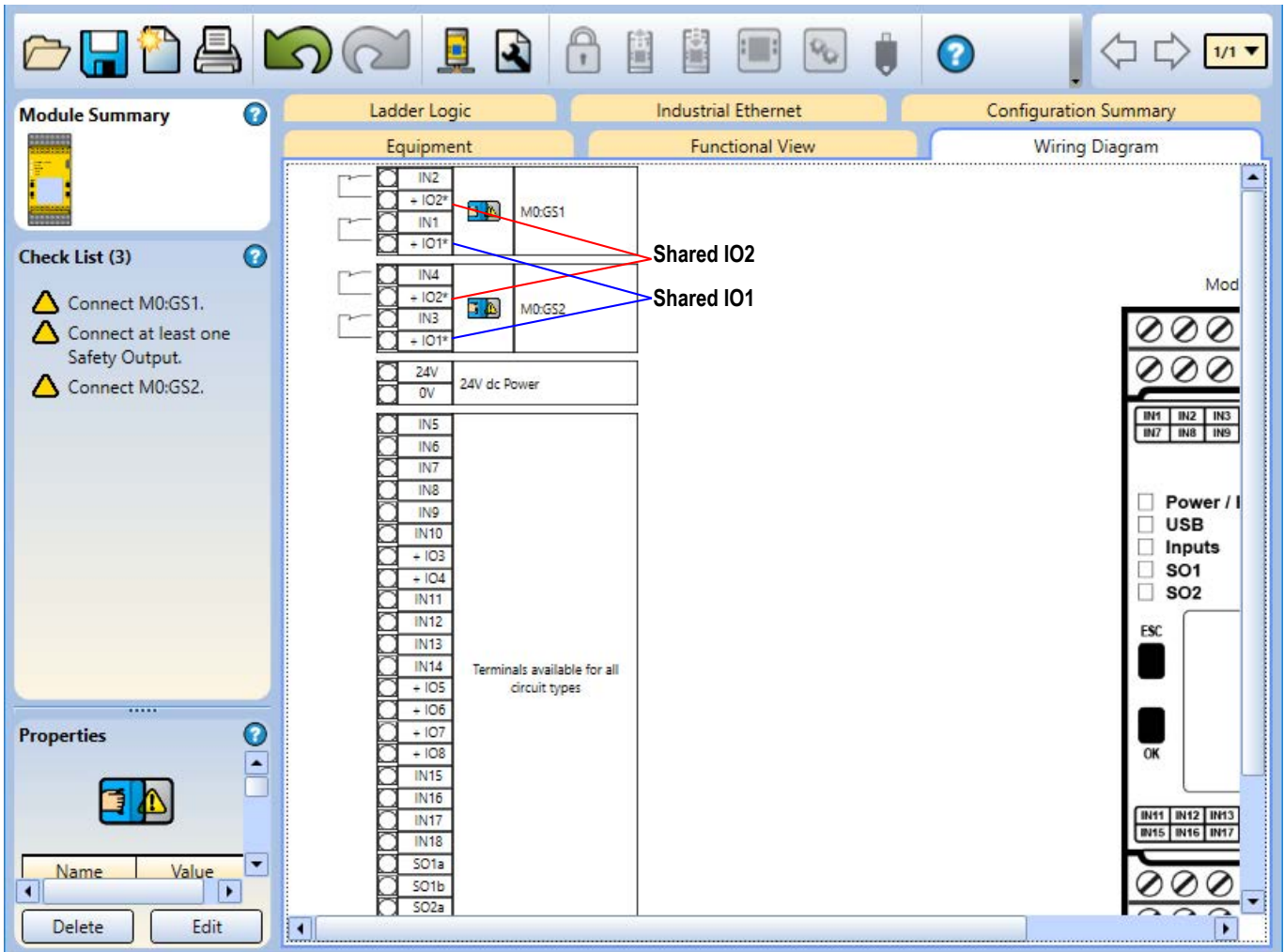

Figure 7. Wiring Diagram Tab View of Shared I/Os



4 SC10-2 Overview

Figure 8. SC10-2 Safety Controller



The SC10-2 configurable safety relay controller is an easy-to-use and cost-effective alternative to safety relay modules. It replaces the functionality and capability of two independent safety relay modules while offering the configurability, simplicity, and advanced diagnostics capabilities offered by the rest of the Banner Engineering Safety Controller line-up.

- In-Series Diagnostics (ISD) provides detailed status and performance data from each connected safety device which can be accessed with an HMI or similar device
- Intuitive, icon-based programming with drag-and-drop PC configuration simplifies device setup and management
- Supports a wide range of safety devices, eliminating the need to buy and stock safety relay modules dedicated to specific safety devices
- Two six-amp safety relay outputs, each with three normally open (NO) sets of contacts
- Ten inputs, including four that can be used as non-safe outputs
- Automatic Terminal Optimization (ATO) can increase the inputs from 10 to up to 14
- Industrial Ethernet two-way communication
 - 256 virtual non-safe status outputs
 - 80 virtual non-safe inputs (reset, ON/OFF, cancel OFF-delay, mute enable)
- Optional SC-XM3 external drive for fast swap and quick configuration without a PC (see [SC10-2: Using the SC-XM3](#) on page 328)

4.1 SC10-2 Models

Model	Description
SC10-2roe	Configurable safety relay controller - 10 inputs (4 convertible), two 3-channel safety relay outputs, industrial ethernet

4.2 SC10-2 Features and Indicators

Connection points are push-in spring clamp connectors.

Wire Size: 24 to 14 AWG, 0.2 mm² to 2.08 mm²



Important: Clamp terminals are designed for one wire only. If more than one wire is connected to a terminal, a wire could loosen or become completely disconnected from the terminal, causing a short. Use a stranded wire or a wire with an accompanying ferrule. Tinned wires are not recommended. After inserting the wire into the terminal, tug the wire to make sure it is properly retained. If the wire is not retained, consider using a different wiring solution.

Figure 9. Features and Indicators

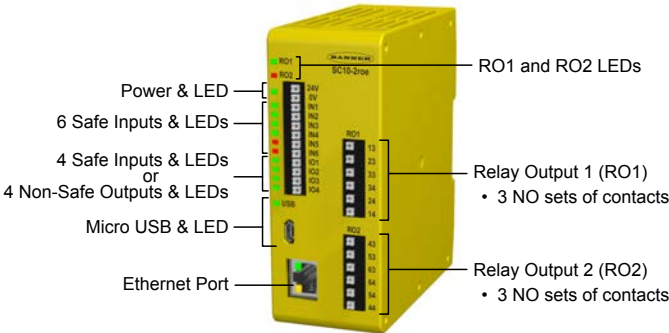

4.3 Using SC10-2 Safety Controllers with Different FIDs

Over time, Banner adds new features to some devices. The Feature ID (FID) identifies the set of features and functions included in a particular model. Generally, an increasing FID number corresponds to an increasing feature set. A configuration using a higher numbered FID feature is not supported by a Safety Controller of a lower FID. Feature sets are forward compatible, not backwards compatible.

Figure 10. Example SC10-2 Label

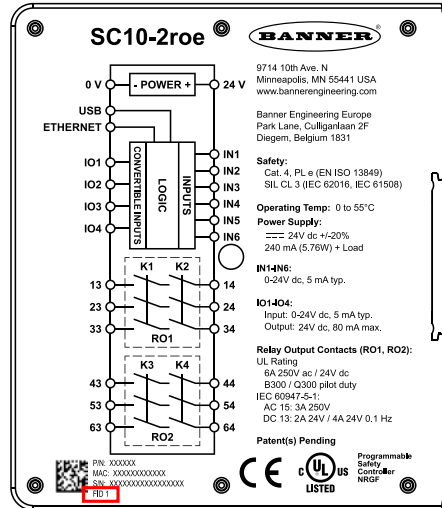
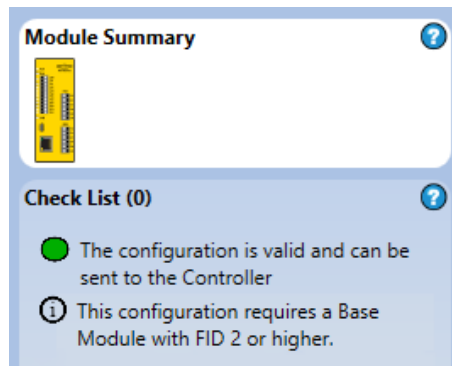

Table 5: FID Descriptions

FID Number	Added Feature Set
FID 1	Initial feature set
FID 2	Added the ability to directly convert In-Series Diagnostic information to USB (using the Software) and Industrial Ethernet protocols.

The checklist in the Banner Safety Controller Software shows a warning when a feature is added that requires a Safety Controller with firmware other than an FID 1 Safety Controller.

Figure 11. Example Checklist Warning



4.4 Input and Output Connections

4.4.1 SC10-2 Safety and Non-Safety Input Devices

The SC10-2 has 10 input terminals that can be used to monitor either safety or non-safety devices; these devices may incorporate either solid-state or contact-based outputs.

Some of the input terminals can be configured to either source 24 V DC for monitoring contacts or to signal the status of an input or an output. The function of each input circuit depends on the type of the device connected; this function is established during the controller configuration.

4.4.2 SC10-2 Safety Relay Outputs

The SC10-2 has two, three-channel, normally open (NO), safety relay outputs.

The Safety Outputs are designed to control Final Switching Devices (FSDs) and Machine Primary Control Elements (MPCEs) that are the last elements (in time) to control the dangerous motion. These control elements include relays, contactors, solenoid valves, motor controls, and other devices that typically incorporate force-guided (mechanically-linked) monitoring contacts, or electrical signals needed for external device monitoring (EDM).

Functional Stops according to IEC 60204-1 and NFPA 79

The Safety Controller is capable of performing two functional stop types:

- Category 0: an uncontrolled stop with the immediate removal of power from the guarded machine
- Category 1: a controlled stop with a delay before power is removed from the guarded machine

Delayed stops can be used in applications where machines need power for a braking mechanism to stop the hazardous motion.

4.4.3 SC10-2 Status Outputs and Virtual Status Outputs

Using the Software, the SC10-2 can be configured for up to 256 virtual status outputs to communicate information over the network. These outputs have the capability to send non-safety status signals to devices such as programmable logic controllers (PLCs) or human-machine interfaces (HMIs). See [Virtual Status Outputs](#) on page 81 for more information.

The SC10-2 has four convertible I/Os (labeled **IOx**) that can be used as Status Outputs to directly control indicator lights or be hard-wired inputs to PLCs. These outputs communicate the same information as the virtual status outputs.



WARNING:

- **Status Outputs and Virtual Status Outputs are not safety outputs and can fail in either the On or the Off state.**
- If a Status Output or a Virtual Status Output is used to control a safety-critical application, a failure to danger is possible and may lead to serious injury or death.
- Never use a Status Output or Virtual Status Output to control any safety-critical applications.

The SC10-2 FID 2 or later can act as an interface to provide data from a chain of devices with imbedded In-Series Diagnostic (ISD) data, such as Banner SI-RF Safety Switches, over the network.

4.5 SC10-2 Automatic Terminal Optimization (ATO) Feature with External Terminal Blocks (ETB)

Automatic Terminal Optimization (ATO) Feature with External Terminal Blocks (ETB) is a standard feature on all SC10-2 models and is enabled by default.

The ATO feature can expand the 10 terminals on the SC10-2 to work with additional inputs by optimizing terminals and using ETBs. As devices are added, deleted, or edited, the Software automatically provides the optimum terminal assignment to minimize wiring and maximize terminal utilization.

ATO is a smart feature that provides all available device types and configuration options as a configuration is created. After all IN and I/O terminals are occupied and another device is added, ATO looks for devices that require +24 V test pulses from the Safety Controller. These devices are combined via an External Terminal Block (ETB) to free up an I/O terminal. Each ETB allows for up to three different devices to share a single I/O +24 V signal.

Disable ATO by editing the module properties of the SC10-2 in the Software, if preferred. ETBs will still be active, but you will be required to re-assign I/O terminals manually as needed to fully optimize terminal utilization.

5 Specifications and Requirements

5.1 XS/SC26 Specifications

Base Controller and Expansion Modules

Mechanical Stress

Shock: 15 g for 11 ms, half-sine wave, 18 shocks total (per IEC 61131-2)
Vibration: 3.5 mm occasional / 1.75 mm continuous at 5 Hz to 49 Hz, 1.0 g occasional and 0.5 g continuous at 9 Hz to 150 Hz: all at 10 sweep cycles per axis (per IEC 61131-2)

Safety

Category 4, PL e (EN ISO 13849)
 SIL CL 3 (IEC 62061, IEC 61508)

Product Performance Standards

See [Standards and Regulations](#) on page 345 for a list of industry applicable U.S. and international standards

EMC

Meets or exceeds all EMC requirements in IEC 61131-2, IEC 62061 Annex E, Table E.1 (increased immunity levels), IEC 61326-1:2006, and IEC61326-3-1:2008

Operating Conditions

Temperature: 0 °C to +55 °C (+32 °F to +131 °F)
Storage Temperature: -30 °C to +65 °C (-22 °F to +149 °F)
Humidity: 90% at +50 °C maximum relative humidity (non-condensing)
Operating Altitude: 2000 m maximum (6562 ft maximum) per IEC 61010-1

Environmental Rating

NEMA 1 (IEC IP20), for use inside NEMA 3 (IEC IP54) or better enclosure

Removable Screw Terminals

Wire size: 24 to 12 AWG (0.2 to 3.31 mm²)
Wire strip length: 7 to 8 mm (0.275 in to 0.315 in)
Tightening torque: 0.565 N·m (5.0 in-lb)

Removable Clamp Terminals

Important: *Clamp terminals are designed for one wire only. If more than one wire is connected to a terminal, a wire could loosen or become completely disconnected from the terminal, causing a short. If more than one wire is required, a ferrule or an external terminal block should be used.*
Wire size: 24 to 16 AWG (0.20 to 1.31 mm²)
Wire strip length: 8.00 mm (0.315 in)



Important: The power supply must meet the requirements for extra low voltages with protective separation (SELV, PELV).

XS26-2, SC26-2, and XS26-ISD Base Safety Controller Modules

Power

24 V DC ± 20% (incl. ripple), 100 mA no load
Ethernet models: add 40 mA
Display models: add 20 mA
Expandable models: 3.6 A maximum bus load

Network Interface (Ethernet models only)

Ethernet 10/100 Base-T/TX, RJ45 modular connector
 Selectable auto-negotiate or manual rate and duplex
 Auto MDI/MDIX (auto-cross)
Protocols: ⁴ EtherNet/IP™ (with PCCC), Modbus® TCP, PROFINET® (FID 2 or later), and EtherCAT® (requires XSeCAT gateway)
Data: 64 configurable virtual Status Outputs on FID 1 XS/SC26 Safety Controllers or 256 virtual Status Outputs on FID 2 or later XS/SC26 Safety Controllers; fault diagnostic codes and messages; access to fault log

Convertible I/O

Sourcing current: 80 mA maximum (overcurrent protected)
 Test Pulses: about 1 ms every 25 ms to 75 ms

Automatic Terminal Optimization Feature

Up to two devices

Test Pulse

Width: 200 µs maximum
Rate: 200 ms typical

Output Protection

All solid-state outputs (safety and non-safety) are protected from shorts to 0 V or +24 V, including overcurrent conditions

Safety Ratings

PFH [1/h]: 1.05 × 10⁻⁹
Proof Test Interval: 20 years

Safety Inputs (and Convertible I/O when used as inputs)

Input ON threshold: > 15 V DC (guaranteed on), 30 V DC max.
Input OFF threshold: < 5 V DC and < 2 mA, -3 V DC min.
Input ON current: 5 mA typical at 24 V DC, 50 mA peak contact cleaning current at 24 V DC
Input lead resistance: 300 Ω max. (150 Ω per lead)
Input requirements for a 4-wire Safety Mat:
 · Max. capacity between plates: 0.22 µF
 · Max. capacity between bottom plate and ground: 0.22 µF
 · Max. resistance between the 2 input terminals of one plate: 20 Ω

Solid-State Safety Outputs

0.5 A max. at 24 V DC (1.0 V DC max. drop), 1 A max. inrush
Output OFF threshold: 1.7 V DC typical (2.0 V DC max.)
Output leakage current: 50 µA max. with open 0 V
Load: 0.1 µF max., 1 H max., 10 Ω max. per lead

Response and Recovery Times

Input to Output Response Time (Input Stop to Output Off): see the Configuration Summary in the Software, as it can vary
Input Recovery Time (Stop to Run): ON-Delay (if set) plus 250 ms typical (400 ms maximum)
Output xA to Output xB turn On differential (used as a pair, not split): 5 ms max.
Output X to Output Y turn on Differential (same input, same delay, any module): 3 scan times + 25 ms maximum
Virtual Input (Mute Enable and On/Off) Timing (FID 2 or later): RPI + 200 ms typical
Virtual Input (Manual Reset and Cancel Delay) Timing (FID 2 or later): see [Virtual Non-Safety Input Devices](#) on page 60 for details

OFF-Delay Tolerance

The maximum is the response time given in the configuration summary plus 0.02%
 The minimum is the configured OFF-Delay time minus 0.02% (assuming no power loss or faults)

ON-Delay Tolerance

The maximum is the configured ON-Delay plus 0.02% plus 250 ms typical (400 ms maximum)
 The minimum is the configured ON-Delay minus 0.02%

⁴ EtherNet/IP™ is a trademark of ODVA, Inc.; Modbus® is a registered trademark of Schneider Electric USA, Inc.; PROFINET® is a registered trademark of PROFIBUS Nutzerorganisation e.V.; EtherCAT® is a registered trademark and patented technology, licensed by Beckhoff Automation GmbH, Germany.

Certifications



IND. CONT. EQ.
3NFV



Programmable
Safety
Controller
3NBN



EtherNet/IP



Does not apply to XS26-ISDd.



Banner Engineering BV Park Lane, Culliganlaan 2F bus 3, 1831 Diegem, BELGIUM



Turck Banner LTD Blenheim House, Blenheim Court, Wickford, Essex SS11 8YT, Great Britain

Figure 12. XS26-ISD Temperature Derating

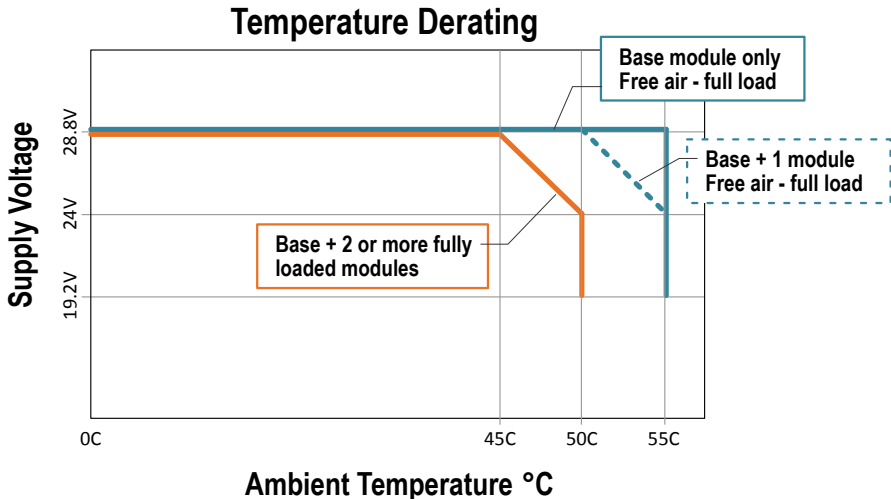

XS2so and XS4so Solid-State Safety Output Modules

Solid-State Safety Outputs

- XS2so:** 0.75 A maximum at 24 V DC (1.0 V DC maximum drop)
- XS4so:** 0.5 A maximum at 24 V DC (1.0 V DC maximum drop)
- Inrush:** 2 A maximum
- Output off threshold:** 1.7 V DC typical (2.0 V DC maximum)
- Output leakage current:** 50 µA maximum with open 0 V
- Load:** 0.1 µF max., 1 H max., 10 Ω maximum per lead

Safety Ratings

- PFH [1/h]:** 5.8 × 10⁻¹⁰
- Proof Test Interval:** 20 years

External Power

- XS2so:** 24 V DC ± 20% (including ripple); 0.075 A no-load, 3.075 A maximum load
- XS4so:** 24 V DC ± 20% (including ripple); 0.1 A no-load, 4.1 A maximum load
- Maximum Power-up Delay:** 5 seconds after the Base Controller
- Limited Isolation:** ±30 V DC maximum referenced to 0 V on the Base Controller

Bus Power

0.02 A

Test Pulse

- Width:** 200 µs maximum
- Rate:** 200 ms typical

Output Protection

All solid-state outputs (safety and non-safety) are protected from shorts to 0 V or +24 V, including overcurrent conditions

Certifications



IND. CONT. EQ.
3NFV



Programmable
Safety
Controller
3NBN



Banner Engineering BV Park Lane, Culliganlaan 2F bus 3, 1831 Diegem, BELGIUM



Turck Banner LTD Blenheim House, Blenheim Court, Wickford, Essex SS11 8YT, Great Britain

XS8si and XS16si Safety Input Modules

Convertible I/O

Sourcing current: 80 mA maximum at 55 °C (131 °F) operating ambient temperature (overcurrent protected)
Test Pulses: about 1 ms every 25 ms to 75 ms

Bus Power

XS8si: 0.07 A no load; 0.23 A maximum load
XS16si: 0.09 A no load; 0.41 A maximum load

Safety Ratings

PFH [1/h]: 4×10^{-10}
Proof Test Interval: 20 years

Safety Inputs (and Convertible I/O when used as inputs)

Input On threshold: > 15 V DC (guaranteed on), 30 V DC maximum
Input Off threshold: < 5 V DC and < 2 mA, -3 V DC minimum
Input On current: 5 mA typical at 24 V DC, 50 mA peak contact cleaning current at 24 V DC
Input lead resistance: 300 Ω max. (150 Ω per lead)
Input requirements for a 4-wire Safety Mat:
 · Maximum capacity between plates: 0.22 μF
 · Maximum capacity between bottom plate and ground: 0.22 μF
 · Maximum resistance between the 2 input terminals of one plate: 20 Ω

Output Protection

The convertible inputs are protected from shorts to 0 V or +24 V, including overcurrent conditions

Certifications



IND. CONT. EQ.
3NFV



Programmable
Safety
Controller
3NBN



Banner Engineering BV Park
Lane, Culliganlaan 2F bus 3, 1831
Diegem, BELGIUM



Turck Banner LTD Blenheim
House, Blenheim Court, Wickford,
Essex SS11 8YT, Great Britain

XS1ro and XS2ro Safety Relay Modules

Bus Power

XS1ro: 0.125 A (outputs On)
XS2ro: 0.15 A (outputs On)

Maximum Power

2000 VA, 240 W

Electrical Life

50,000 cycles at full resistive load

Overvoltage Category

III

Pollution Degree

2

Mechanical Life

40,000,000 cycles



Note: Transient suppression is recommended when switching inductive loads. Install suppressors across load. Never install suppressors across output contacts.

Contact Rating

UL/NEMA:

- **NO Contacts:** 6 A 250 V AC/24 V DC resistive; B300/Q300 pilot duty
- **NC Contacts:** 2.5 A 150 V AC/24 V DC resistive; Q300 pilot duty

IEC 60947-5-1:

- **NO Contacts:** 6 A 250 V AC/DC continuous; AC 15: 3 A 250 V; DC13: 1 A 24 V/4 A 24 V 0.1 Hz
- **NC Contacts:** 2.5 A 150 V AC/DC continuous; AC 15: 1 A 150 V; DC13: 1 A 24 V/4 A 24 V 0.1 Hz

Contact Ratings to preserve 5 μm AgNi gold plating

	Minimum	Maximum
Voltage	100 mV AC/DC	60 V AC/DC
Current	1 mA	300 mA
Power	1 mW (1 mVA)	7 W (7 VA)

Safety Ratings

PFH [1/h]: 7.6×10^{-10}
 Proof Test Interval: 20 years

B10d Values

Voltage	Current	B10d
230 V AC	3 A	300,000
230 V AC	1 A	750,000
24 V DC	≤ 2 A	1,500,000

Required Overcurrent Protection



WARNING: Electrical connections must be made by qualified personnel in accordance with local and national electrical codes and regulations.

Overcurrent protection is required to be provided by end product application per the supplied table. Overcurrent protection may be provided with external fusing or via Current Limiting, Class 2 Power Supply. Supply wiring leads < 24 AWG shall not be spliced. For additional product support, go to www.bannerengineering.com.

Supply Wiring (AWG)	Required Overcurrent Protection (Amps)
20	5.0
22	3.0
24	2.0
26	1.0
28	0.8
30	0.5

Certifications



Banner Engineering BV Park Lane, Culliganlaan 2F bus 3, 1831 Diegem, BELGIUM



Turck Banner LTD Blenheim House, Blenheim Court, Wickford, Essex SS11 8YT, Great Britain

XSeCAT EtherCAT Communications Gateway Module

Network Interface

EtherCAT® 5
Data Transmission Rate: 100 Mbits/s, 100 Base-T Autosensing
Connection Type: Two female RJ-45 connectors

Mechanical Stress

Shock: 15 g for 11 ms, half-sine wave, 18 shocks total (per IEC 61131-2)
Vibration: 3.5 mm occasional / 1.75 mm continuous at 5 Hz to 9 Hz, 1.0 g occasional and 0.5 g continuous at 9 Hz to 150 Hz: all at 10 sweep cycles per axis (per IEC 61131-2)

Certifications



EMC

Meets or exceeds all EMC requirements in IEC 61131-2, IEC 62061 Annex E, Table E.1 (increased immunity levels), IEC 61326-1:2006, and IEC61326-3-1:2008

Bus Power

0.06 A

Operating Conditions

Temperature: 0 °C to +55 °C (+32 °F to +131 °F)
Storage Temperature: -30 °C to +65 °C (-22 °F to +149 °F)
Humidity: 90% at +50 °C maximum relative humidity (non-condensing)
Operating Altitude: 2000 m maximum (6562 ft maximum) per IEC 61010-1

Environmental Rating

NEMA 1 (IEC IP20), for use inside NEMA 3 (IEC IP54) or better enclosure

5 EtherCAT® is a registered trademark and patented technology, licensed by Beckhoff Automation GmbH, Germany.

5.2 SC10-2 Specifications

Power

Voltage: 24 V DC $\pm 20\%$ (SELV)

Current:

240 mA maximum, no-load (relays on)

530 mA maximum, full-load (IO1 to IO4 used as auxiliary outputs)

Safety Inputs (and Convertible I/O when used as inputs)

Input ON threshold: > 15 V DC (guaranteed on), 30 V DC maximum

Input OFF threshold: < 5 V DC and < 2 mA, -3 V DC minimum

Input ON current: 5 mA typical at 24 V DC, 50 mA peak contact cleaning current at 24 V DC

Input lead resistance: 300 Ω maximum (150 Ω per lead)

Input requirements for a 4-wire Safety Mat:

- Maximum capacity between plates: 0.22 μF ⁶

- Maximum capacity between bottom plate and ground: 0.22 μF ⁶

- Maximum resistance between the 2 input terminals of one plate: 20 Ω

Response and Recovery Times

Input to Output Response Time (Input Stop to Output Off): see the Configuration Summary in the Software, as it can vary

Input Recovery Time (Stop to Run): ON-Delay (if set) plus 250 ms typical (400 ms maximum)

Virtual Input (Mute Enable and On/Off) Timing: RPI + 200 ms typical

Virtual Input (Manual Reset and Cancel Delay) Timing: see [Virtual Non-Safety Input Devices](#) on page 60 for details

OFF-Delay Tolerance

The maximum is the response time given in the configuration summary plus 0.02%

The minimum is the configured OFF-delay time minus 0.02% (assuming no power loss or faults)

ON-Delay Tolerance

The maximum is the configured ON-delay plus 0.02% plus 250ms typical (400 ms maximum)

The minimum is the configured ON-delay minus 0.02%

Safety Outputs

3 NO sets of contacts for each output channel (RO1 and RO2). Each normally open output is a series connection of contacts from two forced-guided (mechanically linked) relays. RO1 consists of relays K1 and K2. RO2 consists of relays K3 and K4.

Convertible I/O

Sourcing current: 80 mA maximum (overcurrent protected)

Test Pulses: ~1 ms every 25 to 75 ms

Automatic Terminal Optimization Feature

Up to three devices connected with user-provided terminal blocks

Network Interface

Ethernet 10/100 Base-T/TX, RJ45 modular connector

Selectable auto negotiate or manual rate and duplex

Auto MDI/MDIX (auto cross)

Protocols: ⁷ EtherNet/IP™ (with PCCC), Modbus® TCP, and PROFINET®

Data: 256 virtual Status Outputs; fault diagnostic codes and messages; access to fault log

Operating Conditions

Temperature: 0 °C to +55 °C (+32 °F to +131 °F) (see Temperature Derating graph)

Storage Temperature: -30 °C to +65 °C (-22 °F to +149 °F)

Humidity: 90% at +50 °C maximum relative humidity (non-condensing)

Operating Altitude: 2000 m maximum (6562 ft maximum) per IEC 61010-1

Environmental Rating

NEMA 1 (IEC IP20), for use inside NEMA 3 (IEC IP54) or better enclosure

Mechanical Stress

Shock: 15 g for 11 ms, half-sine wave, 18 shocks total (per IEC 61131-2)

Vibration: 3.5 mm occasional / 1.75 mm continuous at 5 Hz to 9 Hz, 1.0 g occasional and 0.5 g continuous at 9 Hz to 150 Hz: all at 10 sweep cycles per axis (per IEC 61131-2)

⁶ If the safety mats share a convertible I/O, this is the total capacitance of all shared safety mats.

⁷ EtherNet/IP™ is a trademark of ODVA, Inc. Modbus® is a registered trademark of Schneider Electric USA, Inc. PROFINET® is a registered trademark of PROFIBUS Nutzerorganisation e.V.

Contacts

AgNi + 0.2 µm gold

Overvoltage Category

Output relay contact voltage of 1 V to 150 V AC/DC: Category III Output relay contact voltage of 151 V to 250 V AC/DC: Category II (Category III, if appropriate overvoltage reduction is provided, as described in this document.)

Individual Contact Current Rating

Refer to the Temperature Derating graph when more than one contact output is used.

	Minimum	Maximum
Voltage	10 V AC/DC	250 V AC / 24 V DC
Current	10 mA AC/DC	6 A
Power	100 mW (100 mVA)	200 W (2000 VA)

Switching Capacity (IEC 60947-5-1)

AC 15	NO: 250 V AC, 3 A
DC 13	NO: 24 V DC, 2 A
DC 13 at 0.1 Hz	NO: 24 V DC, 4 A

EMC

Meets or exceeds all EMC requirements for immunity per IEC 61326-3-1:2012 and emissions per CISPR 11:2004 for Group 1, Class A equipment



Note: Transient suppression is recommended when switching inductive loads. Install suppressors across load. Never install suppressors across output contacts (see Warning).

Safety

Category 4, PL e (EN ISO 13849)
SIL CL 3 (IEC 62061, IEC 61508)

Safety Ratings

PFH [1/h]: 5.01×10^{-10}
Proof Test Interval: 20 years

Product Performance Standards

See [Standards and Regulations](#) on page 345 for a list of industry applicable U.S. and international standards

Mechanical Life

20,000,000 cycles

Electrical Life

50,000 cycles at full resistive load

UL Pilot Duty

B300 Q300

B10d Values

Voltage	Current	B10d
230 V AC	2 A	350,000
230 V AC	1 A	1,000,000
24 V DC	≤ 4 A	10,000,000

Push-in Spring Clamp Terminals

Wire Size: 24 to 14 AWG, 0.2 mm² to 2.08 mm²



Important: Clamp terminals are designed for one wire only. If more than one wire is connected to a terminal, a wire could loosen or become completely disconnected from the terminal, causing a short.

Use a stranded wire or a wire with an accompanying ferrule. Tinned wires are not recommended.

After inserting the wire into the terminal, tug the wire to make sure it is properly retained. If the wire is not retained, consider using a different wiring solution.

Required Overcurrent Protection



WARNING: Electrical connections must be made by qualified personnel in accordance with local and national electrical codes and regulations.

Overcurrent protection is required to be provided by end product application per the supplied table. Overcurrent protection may be provided with external fusing or via Current Limiting, Class 2 Power Supply. Supply wiring leads < 24 AWG shall not be spliced. For additional product support, go to www.bannerengineering.com.

Supply Wiring (AWG)	Required Overcurrent Protection (Amps)
20	5.0
22	3.0
24	2.0
26	1.0
28	0.8
30	0.5

Certifications



PROGRAMMABLE SAFETY CONTROLLER NRGF



PROFIBUS - PROFITEST



Banner Engineering BV Park Lane, Culliganlaan 2F bus 3, 1831 Diegem, BELGIUM



Turck Banner LTD Blenheim House, Blenheim Court, Wickford, Essex SS11 8YT, Great Britain

Figure 13. SC10-2 Temperature Derating

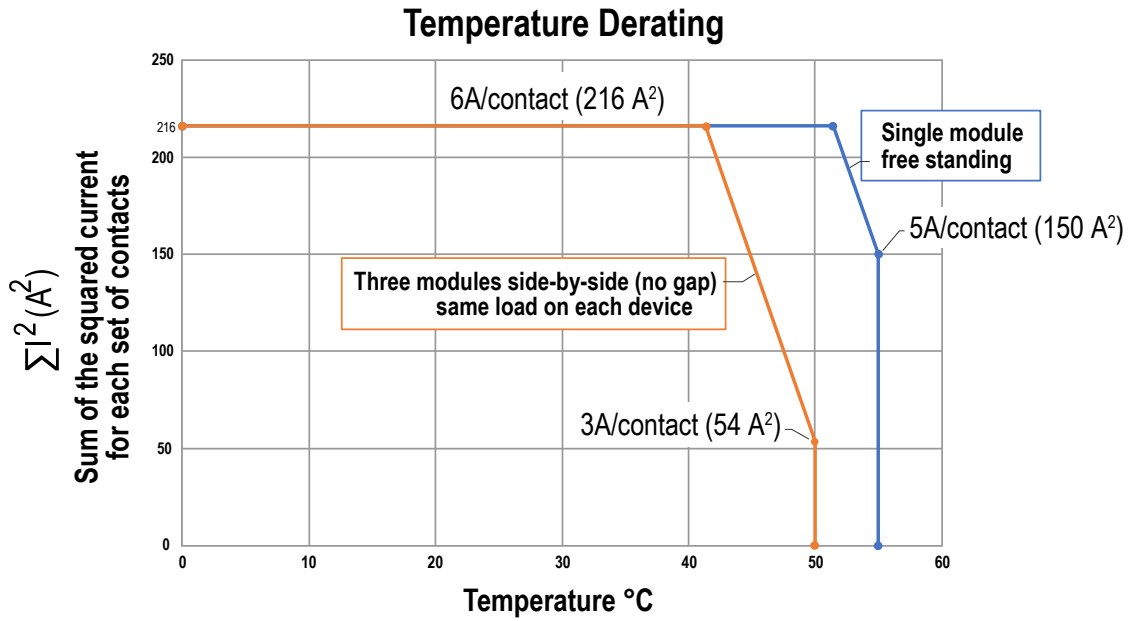

Example Temperature Derating Calculations

Single Unit, Free Standing

$$\sum I^2 = I_1^2 + I_2^2 + I_3^2 + I_4^2 + I_5^2 + I_6^2$$

$I_1 = 4 \text{ A}$ (normally open output RO1 channel 1)

$I_2 = 4 \text{ A}$ (normally open output RO1 channel 2)

$I_3 = 4 \text{ A}$ (normally open output RO1 channel 3)

$I_4 = 4 \text{ A}$ (normally open output RO2 channel 4)

$I_5 = 4 \text{ A}$ (normally open output RO2 channel 5)

$I_6 = 4 \text{ A}$ (normally open output RO2 channel 6)

$$\sum I^2 = 4^2 + 4^2 + 4^2 + 4^2 + 4^2 + 4^2 = 96 \text{ A}^2$$

$T_{\text{max}} = 55 \text{ }^\circ\text{C}$

Three Modules

$$\sum I^2 = I_1^2 + I_2^2 + I_3^2 + I_4^2 + I_5^2 + I_6^2 \text{ (all six modules)}$$

$I_1 = 4 \text{ A}$

$I_2 = 4 \text{ A}$

$I_3 = 4 \text{ A}$

$I_4 = 4 \text{ A}$

$I_5 = 4 \text{ A}$

$I_6 = 4 \text{ A}$

$$\sum I^2 = 4^2 + 4^2 + 4^2 + 4^2 + 4^2 + 4^2 = 96 \text{ A}^2$$

$T_{\text{max}} = 46 \text{ }^\circ\text{C}$

5.3 Dimensions

All measurements are listed in millimeters [inches], unless noted otherwise.

Figure 14. XS/SC26 Base Controller Dimensions

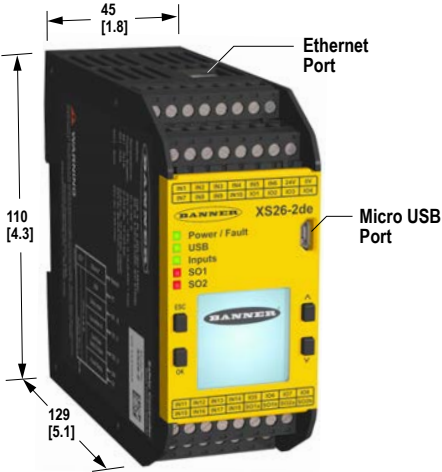

Figure 15. Expansion Module Dimensions

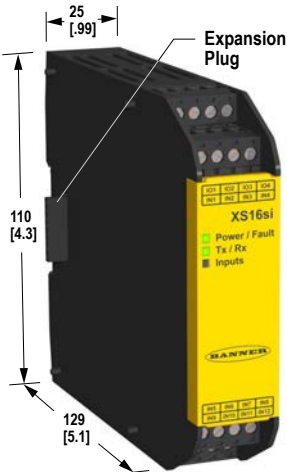

Figure 16. SC10-2 Dimensions

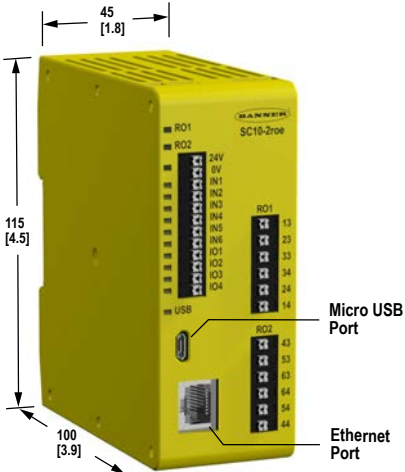

Figure 17. EtherCAT Module



5.4 PC Requirements



Important: Administrative rights are required to install the Safety Controller drivers (needed for communication with the controller).

- Operating system:** Microsoft Windows 7, Windows 10, or Windows 11 ⁸
- System type:** 32-bit, 64-bit
- Hard drive space:** 80 MB (plus up to 280 MB for Microsoft .NET 4.0, if not already installed)
- Memory (RAM):** 512 MB minimum, 1 GB+ recommended
- Processor:** 1 GHz minimum, 2 GHz+ recommended

⁸ Microsoft and Windows are registered trademarks of Microsoft Corporation in the United States and/or other countries.

XS/SC26 and SC10-2 Safety Controllers

Screen resolution:	1024 × 768 full color minimum, 1650 × 1050 full color recommended
Third-party software:	Microsoft .NET 4.0 (included with installer), PDF Viewer (such as Adobe Acrobat)
USB port:	USB 2.0 (not required to build configurations)

6 System Installation

6.1 Installing the Software



Important: Administrative rights are required to install the Safety Controller drivers (needed for communication with the controller).

1. Download the latest version of the software from www.bannerengineering.com/safetycontroller.
2. Navigate to and open the downloaded file.
3. Click **Next** to begin the installation process.
4. Confirm the software destination and availability for users and click **Next**.
5. Click **Install** to install the software.
6. Depending on your system settings, a popup window may appear prompting to allow Banner Safety Controller to make changes to your computer. Click **Yes**.
7. Click **Finish** to exit the installer.

Open **Banner Safety Controller** from the **Desktop** or the **Start Menu**.

6.2 Installing the Safety Controller

Do not exceed the operating specifications for reliable operation. The enclosure must provide adequate heat dissipation so that the air closely surrounding the Safety Controller does not exceed its maximum operating temperature (see [Specifications and Requirements](#) on page 20).



Important: Mount the Safety Controller in a location that is free from large shocks and high-amplitude vibration.



Important:

- **Electrostatic discharge (ESD) sensitive device**
- ESD can damage the device. Damage from inappropriate handling is not covered by warranty.
- Use proper handling procedures to prevent ESD damage. Proper handling procedures include leaving devices in their anti-static packaging until ready for use; wearing anti-static wrist straps; and assembling units on a grounded, static-dissipative surface.

6.2.1 Mounting Instructions

The Safety Controller mounts to a standard 35 mm DIN-rail track. It must be installed inside an enclosure rated NEMA 3 (IEC IP54) or better. It should be mounted to a vertical surface with the vent openings at the bottom and the top to allow for natural convection cooling.

Follow the mounting instructions to avoid damage to the Safety Controller.

To **mount** the SC26-2 Programmable Safety Controller, XS26-2 Programmable Safety Controller, XS26-ISD Programmable Safety Controller, XS2so and XS4so Solid-State Safety Output Modules, XS8si and XS16si Safety Input Modules, XS1ro and XS2ro Safety Relay Modules, XSeCAT EtherCAT Communication Gateway Module, and SC10-2 Safety Controller:

1. Tilt the top of the module slightly backward and place it on the DIN rail.
2. Straighten the module against the rail.
3. Lower the module onto the rail.



Note: If using an EtherCAT module, it must be the first module in the chain, next to the Base Controller.

To **remove** the SC26-2 Programmable Safety Controller, XS26-2 Programmable Safety Controller, XS26-ISD Programmable Safety Controller, XS2so and XS4so Solid-State Safety Output Modules, XS8si and XS16si Safety Input Modules, XS1ro and XS2ro Safety Relay Modules, XSeCAT EtherCAT Communication Gateway Module, and SC10-2 Safety Controller:

1. Push up on the bottom of the module.
2. Tilt the top of the module slightly forward.
3. Lower the module after the top rigid clip is clear of the DIN rail.



Note: To remove an expansion module or communication gateway, pull apart other modules on each side of the desired module to free bus connectors.

7 Installation Considerations

7.1 Appropriate Application

The correct application of the Safety Controller depends on the type of machine and the safeguards that are to be interfaced with the Safety Controller. **If there is any concern about whether or not your machinery is compatible with this Safety Controller, contact Banner Engineering.**

Read this Section Carefully Before Installing the System.

The Safety Controller is a control device that is intended to be used in conjunction with a machine safeguarding device. Its ability to perform this function depends upon the appropriateness of the application and upon the Safety Controller's proper mechanical and electrical installation and interfacing with the machine to be guarded.

If all mounting, installation, interfacing, and checkout procedures are not followed properly, the Safety Controller cannot provide the protection for which it was designed. The user is responsible for satisfying all local, state, and national laws, rules, codes, or regulations relating to the installation and use of this control system in any particular application. Make sure that all safety requirements have been met and that all technical installation and maintenance instructions contained in this document are followed.



WARNING:

- **Not a stand-alone safeguarding device**
- Failure to properly safeguard hazards according to a risk assessment, local regulations, and applicable standards might lead to serious injury or death.
- This Banner Engineering device is considered complementary equipment that is used to augment safeguarding that limits or eliminates an individual's exposure to a hazard without action by the individual or others.



WARNING:

- **User Is Responsible for Safe Application of this device**
- The application examples described in this document depict generalized guarding situations. Every guarding application has a unique set of requirements.
- Make sure that all safety requirements are met and that all installation instructions are followed. Direct any questions regarding safeguarding to Banner Engineering at the number or addresses listed in this document.

7.2 XS/SC26 Applications

The Safety Controller can be used wherever safety modules are used. The Safety Controller is well suited to address many types of applications, including, but not limited to:

- Two-hand control with mute function
- Robot weld/processing cells with dual-zone muting
- Material-handling operations that require multiple inputs and bypass functions
- Manually loaded rotary loading stations
- Multiple two-hand-control station applications
- Lean manufacturing stations
- Dynamic monitoring of single- or dual-solenoid valves or press safety valves

Figure 18. Sample Application - Robotic Cell

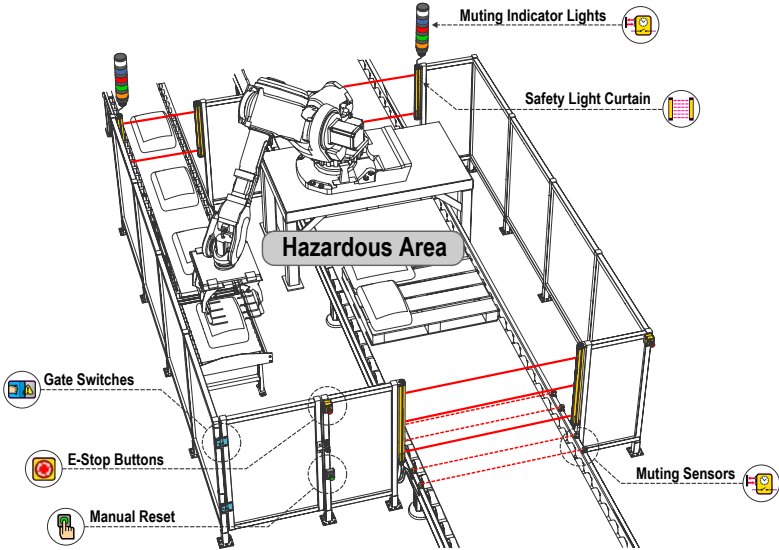

7.3 SC10-2 Applications

The SC10-2 Safety Controller is ideal for a small to medium size machine that would typically use two independent safety relay modules.

Figure 19. SC10-2 Sample Application

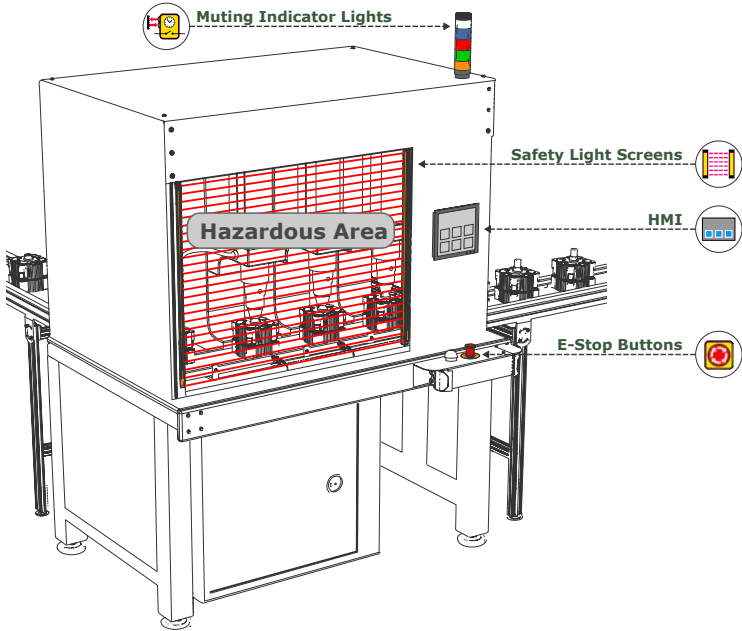

7.4 Safety Input Devices

The Safety Controller monitors the state of the safety input devices that are connected to it. In general, when all of the input devices that have been configured to control a particular Safety Output are in the Run state, the Safety Output turns on or remains On. When one or more of the safety input devices change from Run state to Stop state, the Safety Output turns Off. A few special safety input device functions can, under predefined circumstances, temporarily suspend the safety input stop signal to keep the Safety Output On, for example, muting or bypassing.

The Safety Controller can detect input faults with certain input circuits that would otherwise result in a loss of the control of the safety function. When such faults are detected, the Safety Controller turns the associated outputs Off until the faults are cleared. The function blocks used in the configuration impact the safety outputs. It is necessary to carefully review the configuration if the input device faults occur.

Methods to eliminate or minimize the possibility of these faults include, but are not limited to:

- Physically separating the interconnecting control wires from each other and from secondary sources of power
- Routing interconnecting control wires in separate conduit, runs, or channels
- Locating all control elements (Safety Controller, interface modules, FSDs, and MPCEs) within one control panel, adjacent to each other, and directly connected with short wires
- Properly installing multi-conductor cabling and multiple wires through strain-relief fittings. Over-tightening of a strain-relief can cause short circuits at that point
- Using positive-opening or direct-opening components, as described by IEC 60947-5-1, that are installed and mounted in a positive mode
- Periodically checking the functional integrity/safety function
- Training the operators, maintenance personnel, and others involved with operating the machine and the safeguarding to recognize and immediately correct all failures



Note: Follow the device manufacturer's installation, operation, and maintenance instructions and all relevant regulations. If there are any questions about the device(s) that are connected to the Safety Controller, contact Banner Engineering for assistance.

Figure 20. XS/SC26 Terminal Locations

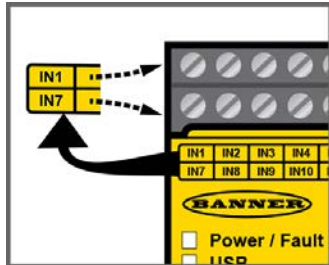
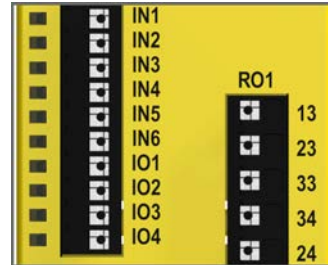

Figure 21. SC10-2 Terminal Locations



WARNING:

- **Input Device and Safety Integrity**
- Failure to follow these instructions could result in serious injury or death.
- The Safety Controller can monitor many different safety input devices. The user must conduct a Risk Assessment of the guarding application to determine what Safety Integrity Level needs to be reached to know how to properly connect the input devices to the Safety Controller.
- The user must also eliminate or minimize possible input signal faults/failures that may result in the loss of the safety functions.

7.4.1 Safety Circuit Integrity and ISO 13849-1 Safety Circuit Principles

Safety circuits involve the safety-related functions of a machine that minimize the level of risk of harm. These safety-related functions can prevent initiation, or they can stop or remove a hazard. The failure of a safety-related function or its associated safety circuit usually results in an increased risk of harm.

The integrity of a safety circuit depends on several factors, including fault tolerance, risk reduction, reliable and well-tried components, well-tried safety principles, and other design considerations.

Depending on the level of risk associated with the machine or its operation, an appropriate level of safety circuit integrity (performance) must be incorporated into its design. Standards that detail safety performance levels include ANSI B11.19 Performance Criteria for Safeguarding and ISO 13849-1 Safety-Related Parts of a Control System.

Safety Circuit Integrity Levels

Safety circuits in International and European standards have been segmented into Categories and Performance Levels, depending on their ability to maintain their integrity in the event of a failure and the statistical likelihood of that failure. ISO 13849-1 details safety circuit integrity by describing circuit architecture/structure (Categories) and the required performance level (PL) of safety functions under foreseeable conditions.

In the United States, the typical level of safety circuit integrity has been called "Control Reliability". Control Reliability typically incorporates redundant control and self-checking circuitry and has been loosely equated to ISO 13849-1 Category 3 or 4 and/or Performance Level "d" or "e" (see ANSI B11.19).

Perform a risk assessment to ensure appropriate application, interfacing/hookup, and risk reduction (see ANSI B11.0 or ISO 12100). The risk assessment must be performed to determine the appropriate safety circuit integrity in order to ensure that the expected risk reduction is achieved. This risk assessment must take into account all local regulations and relevant standards, such as U.S. Control Reliability or European "C" level standards.

The Safety Controller inputs can support up to Category 4 PL e (ISO 13849-1) and Safety Integrity Level 3 (IEC 61508 and IEC 62061) interfacing/hookup. The actual safety circuit integrity level is dependent on the configuration, proper installation of external circuitry, and the type and installation of the safety input devices. The user is responsible for the determination of the overall safety rating(s) and full compliance with all applicable regulations and standards.

The following sections deal only with Category 2, Category 3, and Category 4 applications, as described in ISO 13849-1. The input device circuits shown in the table below are commonly used in safeguarding applications, though other solutions are possible depending on fault exclusion and the risk assessment. The table below shows the input device circuits and the safety category level that is possible if all of the fault detection and fault exclusion requirements are met.



WARNING:

- **Determine the safety category**
- The design and installation of the safety devices and the means of interfacing of those devices could greatly affect the level of safety circuit integrity.
- Perform a risk assessment to determine the appropriate safety circuit integrity level or safety category, as described by ISO 13849-1, to ensure that the expected risk reduction is achieved and that all applicable regulations and standards are met.



WARNING:

- **For input devices with dual contact inputs using two or three terminals, detecting a short between two input channels (contact inputs, but not complementary contacts) is not possible if the two contacts are closed.**
- Failure to follow these instructions could result in serious injury or death.
- A short can be detected when the input is in the Stop state for at least two (2) seconds (see the **INx & IOx input terminals** Tip in [Safety Input Device Options](#) on page 36).



WARNING:

- **Category 2 or 3 Input Shorts**
- It is not possible to detect a short between two input channels (contact inputs, but not complementary contacts) if they are supplied through the same source (for example, the same terminal from the Safety Controller in a dual-channel, 3-terminal wiring, or from an external 24 V supply) and the two contacts are closed.
- Such a short can be detected only when both contacts are open and the short is present for at least two (2) seconds.

Fault Exclusion

An important concept within the requirements of ISO 13849-1 is the probability of the occurrence of a failure, which can be reduced using a technique termed "fault exclusion." The rationale assumes that the possibility of certain well-defined failure(s) can be reduced via design, installation, or technical improbability to a point where the resulting fault(s) can be, for the most part, disregarded—that is, "excluded" in the evaluation.

Fault exclusion is a tool a designer can use during the development of the safety-related part of the control system and the risk assessment process. Fault exclusion allows the designer to design out the possibility of various failures and justify it through the risk assessment process to meet the requirements of ISO 13849-1/-2.

Requirements vary widely for the level of safety circuit integrity in safety applications (that is, Control Reliability or Category/Performance Level) per ISO 13849-1. Although Banner Engineering always recommends the highest level of safety in any application, the user is responsible to safely install, operate, and maintain each safety system and comply with all relevant laws and regulations.



WARNING:

- **Determine the safety category**
- The design and installation of the safety devices and the means of interfacing of those devices could greatly affect the level of safety circuit integrity.
- Perform a risk assessment to determine the appropriate safety circuit integrity level or safety category, as described by ISO 13849-1, to ensure that the expected risk reduction is achieved and that all applicable regulations and standards are met.

7.4.2 Safety Input Device Properties

The Safety Controller is configured via the Software to accommodate many types of safety input devices. See [Adding Inputs and Status Outputs](#) on page 83 for more information on input device configuration.

Reset Logic: Manual or Automatic Reset

A manual reset may be required for safety input devices by using a Latch Reset Block or configuring a safety output for a latch reset before the safety output(s) they control are permitted to turn back On. This is sometimes referred to as “latch” mode because the safety output “latches” to the Off state until a reset is performed. If a safety input device is configured for automatic reset or “trip” mode, the safety output(s) it controls will turn back On when the input device changes to the Run state (provided that all other controlling inputs are also in the Run state).

Connecting the Input Devices

The Safety Controller needs to know what device signal lines are connected to which wiring terminals so that it can apply the proper signal monitoring methods, Run and Stop conventions, and timing and fault rules. The terminals are assigned automatically during the configuration process and can be changed manually using the Software.

Signal Change-of-State Types

Two change-of-state (COS) types can be used when monitoring dual-channel safety input device signals: Simultaneous or Concurrent.

Input Circuit	Input Signal COS Timing Rules	
	Stop State—SO turns Off when ⁹ :	Run State—SO turns On when ¹⁰ :
<p>Dual-Channel A and B Complementary</p> <p>2 Terminals 3 Terminals 2 Terminals, PNP</p>	<p>At least 1 channel (A or B) input is in the Stop state.</p>	<p>Simultaneous: A and B are both in the Stop state and then both switch to the Run state within 3 seconds before outputs turn On.</p> <p>Concurrent: A and B concurrently switch to the Stop state, then both switch to the Run state with no simultaneity to turn outputs On.</p>
<p>Dual-Channel A and B</p> <p>2-Ch, 2 Terminals 2-Ch, 3 Terminals 2-Ch, 4 Terminals 2-Ch, 2 Terminal PNP</p>		
<p>2X Complementary A and B</p> <p>4 Terminals 5 Terminals</p>	<p>At least 1 channel (A or B) within a pair of contacts is in the Stop state.</p>	<p>Simultaneous: A and B are concurrently in the Stop state, then the contacts within a channel switch to the Run state within 400 ms (150 ms for two-hand control), both channels are in the Run state within 3 seconds (0.5 seconds for two-hand control).</p> <p>Concurrent: A and B are concurrently in the Stop state. Contacts within a single-channel switch to the Run state within 3 seconds. There is no simultaneity requirement between the switching of channel A and channel B.</p>

⁹ Safety Outputs turn Off when one of the controlling inputs is in the Stop state.

¹⁰ Safety Outputs turn On only when all of the controlling inputs are in the Run state and after a manual reset is performed (if any safety inputs are configured for Manual reset and were in their Stop state).

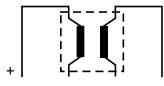
Input Circuit	Input Signal COS Timing Rules	
	Stop State—SO turns Off when ⁹ :	Run State—SO turns On when ¹⁰ :
<p>4-Wire Safety Mat</p> <p>2-Ch, 4 Terminals</p> 	<p>One of the following conditions is met:</p> <ul style="list-style-type: none"> • Input channels are shorted together (normal operation) • At least one of the wires is disconnected • One of the normally low channels is detected high • One of the normally high channels is detected low 	<p>Each channel detects its own pulses.</p>

Signal Debounce Times

Closed-to-Open Debounce Time (from 6 ms to 1000 ms in 1 ms intervals, except 6 ms to 1500 ms for mute sensors).

The closed-to-open debounce time is the time limit required for the input signal to transition from the high (24 V DC) state to the steady low (0 V DC) state. This time limit may need to be increased in cases where high-magnitude device vibration, impact shock, or switch noise conditions result in a need for longer signal transition times. If the debounce time is set too short under these harsh conditions, the system may detect a signal disparity fault and lock out. The default setting is 6 ms.



CAUTION: Debounce and Response—Any changes in the debounce times may affect the Safety Output response (turn OFF) time. This value is computed and displayed for each Safety Output when a configuration is created.

Open-to-Closed Debounce Time (from 10 ms to 1000 ms in 1 ms intervals, except 10 ms to 1500 ms for mute sensors).













The open-to-closed debounce time is the time limit required for the input signal to transition from the low (0 V DC) state to the steady high (24 V DC) state. This time limit may need to be increased in cases where high magnitude device vibration, impact shock, or switch noise conditions result in a need for longer signal transition times. If the debounce time is set too short under these harsh conditions, the system may detect a signal disparity fault and lock out. The default setting is 50 ms.

⁹ Safety Outputs turn Off when one of the controlling inputs is in the Stop state.

¹⁰ Safety Outputs turn On only when all of the controlling inputs are in the Run state and after a manual reset is performed (if any safety inputs are configured for Manual reset and were in their Stop state).

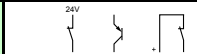
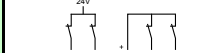
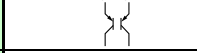
7.5 Safety Input Device Options

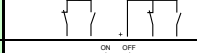
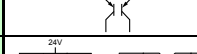
Figure 22. Input Device Circuit—Safety Category Guide

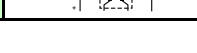
General Circuit Symbols		Circuits shown in Run State							Circuits shown in Stop State	
		ES 	GS 	OS 	RP 	PS 	SM 	ISD 	THC 	ED 
1 & 2 Terminal Single Channel (see note 1)		Cat 2	Cat 2	Cat 2	Cat 2	Cat 2				
2 & 3 Terminal Dual Channel (see note 2)		Cat 3	Cat 3	Cat 3	Cat 3	Cat 3			Type IIIa Cat 1 Type IIIb Cat 3	Cat 3
2 Terminal Dual Channel PNP w/ integral monitoring (see note 3)		Cat 4	Cat 4	Cat 4	Cat 4	Cat 4		Cat 4	Type IIIa Cat 1	Cat 4
3 & 4 Terminal Dual Channel (see notes 2 & 4)		Cat 4	Cat 4	Cat 4	Cat 4	Cat 4			Type IIIa Cat 1 Type IIIb Cat 3	Cat 4
2 & 3 Terminal Dual Channel Complementary			Cat 4	Cat 4	Cat 4	Cat 4				Cat 4
2 Terminal Dual Channel Complementary PNP			Cat 4	Cat 4	Cat 4	Cat 4				Cat 4
4 & 5 Terminal Dual Channel Complementary			Cat 4						Type IIIc Cat 4	Cat 4
4 Terminal Dual Channel Complementary PNP			Cat 4						Type IIIc Cat 4	Cat 4
4 Terminal Safety Mat							Cat 3			



Note:

1. Circuit typically meets up to ISO 13849-1 Category 2 if input devices are safety rated and fault exclusion wiring practices prevent a) shorts across the contacts or solid-state devices and b) shorts to other power sources.
2. Circuit typically meets up to ISO 13849-1 Category 3 if input devices are safety rated (see **Tip: INx & IOx input terminals**, following).
The 2 Terminal circuit detects a single-channel short to other power sources when the contacts open and close again (concurrency fault).
The 3 Terminal circuit detects a short to other power sources whether the contacts are open or closed.
3. Circuit meets up to ISO 13849-1 Category 4 if input devices are safety rated and provide internal monitoring of the PNP outputs to detect a) shorts across channels and b) shorts to other power sources.
4. Circuit meets up to ISO 13849-1 Category 4 if input devices are safety rated (see **Tip: INx & IOx input terminals** above). These circuits can detect both shorts to other power sources and shorts between channels.



CAUTION:

- **Incomplete installation information**
- Many installation considerations necessary to properly apply these devices are not covered by this document.
- Refer to the appropriate device installation instructions to ensure the safe application of the device.



WARNING: This table lists the highest safety categories possible for common safety-rated input device circuits. If the additional requirements stated in the following notes are not possible due to safety device or installation limitations, or if, for example, the Safety Controller's IOx input terminals are all in use, then the highest safety category may not be possible.



Tip: INx & IOx input terminals, these circuits can be manually configured to meet Category 4 circuit requirements by changing the first (left most) standard input terminal (INx) to any available convertible terminal (IOx) as shown below. These circuits will detect shorts to other power sources and between channels when the input has been in the Stop state for at least 2 seconds.

Figure 23. Manually Configured Circuits



7.5.1 Safety Circuit Integrity Levels

The application requirements for safeguarding devices vary for the level of control reliability or safety category per ISO 13849-1. While Banner Engineering always recommends the highest level of safety in any application, the user is responsible to safely install, operate, and maintain each safety system and comply with all relevant laws and regulations.

The safety performance (integrity) must reduce the risk from identified hazards as determined by the machine's risk assessment. See [Safety Circuit Integrity and ISO 13849-1 Safety Circuit Principles](#) on page 32 for guidance.

7.5.2 Emergency Stop Push Buttons

The Safety Controller safety inputs may be used to monitor Emergency Stop (E-stop) push buttons.



WARNING:

- **Do not mute or bypass any emergency stop device**
- Muting or bypassing the safety outputs renders the emergency stop function ineffective.
- ANSI B11.19, NFPA 79 and IEC/EN 60204-1 require that the emergency stop function remains active at all times.



WARNING:

- **Configuration Conforms to Applicable Standards**
- Failure to verify the application may result in serious injury or death.
- The Banner Safety Controller Software primarily checks the logic configuration for connection errors. The user is responsible for verifying the application meets the risk assessment requirements and that it conforms to all applicable standards.



WARNING:

- **Reset routine required**
- Failure to prevent the machine from restarting without actuating the normal start command/device can create an unsafe condition that could result in serious injury or death.
- Do not allow the machine to restart without actuating the normal start command/device. Perform the reset routine after clearing the cause of a stop condition, as required by U.S. and international standards.

In addition to the requirements stated in this section, the design and installation of the Emergency Stop device must comply with NFPA 79 or ISO 13850. The stop function must be either a functional stop Category 0 or a Category 1 (see NFPA79).

Emergency Stop Push Button Requirements

The E-stop switch must provide one or two contacts for safety which are closed when the switch is armed. When activated, the E-stop switch must open all its safety-rated contacts, and must require a deliberate action (such as twisting, pulling, or unlocking) to return to the closed-contact, armed position. The switch must be a positive-opening (or direct-opening) type, as described by IEC 60947-5-1. A mechanical force applied to such a button (or switch) is transmitted directly to the contacts, forcing them to open. This ensures that the switch contacts open whenever the switch is activated.

Standards NFPA 79, ANSI B11.19, IEC/EN 60204-1, and ISO 13850 specify additional emergency stop switch device requirements, including the following:

- Emergency Stop push buttons must be located at each operator control station and at other operating stations where emergency shutdown is required
- Stop and Emergency Stop push buttons must be continuously operable and readily accessible from all control and operating stations where located. **Do not mute or bypass any E-stop button**
- Actuators of emergency stop devices must be colored red. The background immediately around the device actuator must be colored yellow. The actuator of a push-button-operated device must be of the palm or mushroom-head type
- The emergency stop actuator must be a self-latching type



Note: Some applications may have additional requirements; the user is responsible to comply with all relevant regulations.



Note: For Banner Lighted E-stop buttons with ISD, see also [ISD Inputs](#) on page 49. The user must ensure the input is not muted or bypassed. This is because the controller applies gate switch rules because the E-stop is added as device type: ISD input, and then selected as an emergency stop.

7.5.3 Rope (Cable) Pull

Rope (cable) pull emergency stop switches use steel wire rope; they provide emergency stop actuation continuously over a distance, such as along a conveyor.

Rope pull emergency stop switches have many of the same requirements as Emergency Stop push buttons, such as positive (direct) opening operation, as described by IEC 60947-5-1. See [Emergency Stop Push Buttons](#) on page 37 for additional information.

In emergency stop applications, the rope pull switches must have the capability not only to react to a pull in any direction, but also to a slack or a break of the rope. Emergency stop rope pull switches also need to provide a latching function that requires a manual reset after actuation.

Rope (Cable) Pull Installation Guidelines

NFPA 79, ANSI B11.19, IEC/EN 60204-1, and ISO 13850 specify emergency stop requirements for rope (cable) pull installations, including the following:

- Rope (cable) pulls must be located where emergency shutdown is required
- Rope (cable) pulls must be continuously operable, easily visible, and readily accessible; do not mute or bypass
- Rope (cable) pulls must provide constant tension of the rope (cable) pull
- Rope (cable) pulls, as well as any flags or markers, must be colored red
- Rope (cable) pulls must have the capability to react to a force in any direction
- The switch must:
 - Have a self-latching function that requires a manual reset after actuation
 - Have a direct opening operation
 - Detect a slack condition or a break of the rope (cable)

Additional installation guidelines:

- The wire rope (cable) should be easily accessible, red in color for E-Stop functions, and visible along its entire length. Markers or flags may be fixed on the rope (cable) to increase its visibility
- Mounting points, including support points, must be rigid and allow sufficient space around the rope (cable) to allow easy access
- The rope (cable) should be free of friction at all supports. Pulleys are recommended. Lubrication may be necessary. Contamination of the system, such as dirt, metal chips or swarf, etc., must be prevented from adversely affecting operation
- Use only pulleys (not eye bolts) when routing the rope (cable) around a corner or whenever direction changes, even slightly
- Never run rope (cable) through conduit or other tubing
- Never attach weights to the rope (cable)
- A tensioning spring is recommended to ensure compliance with direction-independent actuation of the wire rope (cable) and must be installed on the load-bearing structure (machine frame, wall, etc.)
- Temperature affects rope (cable) tension. The wire rope (cable) expands (lengthens) when temperature increases, and contracts (shrinks) when temperature decreases. Significant temperature variations require frequent checks of the tension adjustment



WARNING: Failure to follow the installation guidelines and procedures may result in the ineffectiveness or non-operation of the Rope (Cable) Pull system and create an unsafe condition resulting in a serious injury or death.

7.5.4 Enabling Device

An enabling device is a manually operated control which, when continuously actuated, allows a machine cycle to be initiated in conjunction with a start control. Standards that cover the design and application of enabling devices include: ISO 12100-1/-2, IEC 60204-1, NFPA 79, ANSI/RIA R15.06, and ANSI B11.19.

The enabling device actively controls the suspension of a Stop signal during a portion of a machine operation where a hazard may occur. The enabling device permits a hazardous portion of the machine to run, but must not start it. An enabling device can control one or more safety outputs. When the enable signal switches from the Stop state to the Run state, the Safety Controller enters the Enable mode. A separate machine command signal from another device is needed to start the hazardous motion. **This enabling device must have ultimate hazard turn Off or Stop authority.**

7.5.5 Protective (Safety) Stop

A Protective (Safety) Stop is designed for the connection of miscellaneous devices that could include safeguarding (protective) devices and complementary equipment. This stop function is a type of interruption of operation that allows an orderly cessation of motion for safeguarding purposes. The function can be reset or activated either automatically or manually.

Protective (Safety) Stop Requirements

The required safety circuit integrity level is determined by a risk assessment and indicates the level of control performance that is acceptable, for example, category 4, Control Reliability (see [Safety Circuit Integrity and ISO 13849-1 Safety Circuit Principles](#) on page 32). The protective stop circuit must control the safeguarded hazard by causing a stop of the hazardous situation(s), and removing power from the machine actuators within the safety function response time. This functional stop typically meets category 0 or 1 as described by NFPA 79 and IEC60204-1.

7.5.6 Interlocked Guard or Gate

The Safety Controller safety inputs may be used to monitor electrically interlocked guards or gates.

Safety Interlock Switch Requirements

The following general requirements and considerations apply to the installation of interlocked guards and gates for the purpose of safeguarding. In addition, the user must refer to the relevant regulations to ensure compliance with all necessary requirements.

Hazards guarded by the interlocked guard must be prevented from operating until the guard is closed; a stop command must be issued to the guarded machine if the guard opens while the hazard is present. Closing the guard must not, by itself, initiate hazardous motion; a separate procedure must be required to initiate the motion. The safety interlock switches must not be used as a mechanical or end-of-travel stop.

The guard must be located an adequate distance from the danger zone (so that the hazard has time to stop before the guard is opened sufficiently to provide access to the hazard), and it must open either laterally or away from the hazard, not into the safeguarded area. The guard also should not be able to close by itself and activate the interlocking circuitry. In addition, the installation must prevent personnel from reaching over, under, around, or through the guard to the hazard. Any openings in the guard must not allow access to the hazard (see OSHA 29CFR1910.217 Table O-10, ANSI B11.19, ISO 13857, EN ISO14120 or the appropriate standard). The guard must be strong enough to contain hazards within the guarded area, which may be ejected, dropped, or emitted by the machine.

The safety interlock switches, actuators, sensors, and magnets must be designed and installed so that they cannot be easily defeated. They must be mounted securely so that their physical position cannot shift, using reliable fasteners that require a tool to remove them. Mounting slots in the housings are for initial adjustment only; final mounting holes must be used for permanent location.



WARNING: If the application could result in a pass-through hazard (for example, perimeter guarding), either the safeguarding device or the guarded machine's MSCs/MPCEs must cause a Latched response following a Stop command (for example, interruption of the sensing field of a light curtain, or opening of an interlocked gate/guard). The reset of this Latched condition may only be achieved by actuating a reset switch that is separate from the normal means of machine cycle initiation. The switch must be positioned as described in this document.

**WARNING:**

- **Perimeter guarding applications**
- Failure to observe this warning could result in serious injury or death.
- Use lockout/tagout procedures per ANSI Z244.1, or use additional safeguarding as described by ANSI B11.19 safety requirements or other applicable standards if a passthrough hazard cannot be eliminated or reduced to an acceptable level of risk.

7.5.7 Optical Sensor

The Safety Controller safety inputs may be used to monitor optical-based devices that use light as a means of detection.

Optical Sensor Requirements

When used as safeguarding devices, optical sensors are described by IEC61496-1/-2/-3 as Active Opto-electronic Protective Devices (AOPD) and Active Opto-electronic Protective Devices responsive to Diffuse Reflection (AOPDDR).

AOPDs include safety light curtains and safety grids and points (multiple-/single-beam devices). These devices generally meet Type 2 or Type 4 design requirements. A Type 2 device is allowed to be used in a Category 2 application, per ISO 13849-1, and a Type 4 device can be used in a Category 4 application.

AOPDDRs include area or laser scanners. The primary designation for these devices is a Type 3, for use in up to Category 3 applications.

Optical safety devices must be placed at an appropriate safety distance (minimum distance), according to the application standards. Refer to the applicable standards and to manufacturer documentation specific to your device for the appropriate calculations. The response time of the Safety Controller outputs to each safety input is provided on the **Configuration Summary** tab in the Software.

If the application includes a pass-through hazard (a person could pass through the optical device beams and stand undetected on the hazard side), other safeguarding may be required, and manual reset should be selected (see [Manual Reset Input](#) on page 59).



WARNING: If the application could result in a pass-through hazard (for example, perimeter guarding), either the safeguarding device or the guarded machine's MSCs/MPCEs must cause a Latched response following a Stop command (for example, interruption of the sensing field of a light curtain, or opening of an interlocked gate/guard). The reset of this Latched condition may only be achieved by actuating a reset switch that is separate from the normal means of machine cycle initiation. The switch must be positioned as described in this document.

7.5.8 Two-Hand Control

The Safety Controller may be used as an initiation device for most powered machinery when machine cycling is controlled by a machine operator.

The Two-Hand Control (THC) actuators must be positioned so that hazardous motion is completed or stopped before the operator can release one or both of the buttons and reach the hazard (see [Two-Hand Control Safety Distance \(Minimum Distance\)](#) on page 41).

The Safety Controller safety inputs used to monitor the actuation of the hand controls for two-hand control comply with the functionality of Type III requirements of IEC 60204-1 and ISO 13851 and the requirements of NFPA 79 and ANSI B11.19 for two-hand control, which include:

- Simultaneous actuation by both hands within a 500 ms time frame
- When this time limit is exceeded, both hand controls must be released before operation is initiated
- Continuous actuation during a hazardous condition
- Cessation of the hazardous condition if either hand control is released
- Release and re-actuation of both hand controls to re-initiate the hazardous motion or condition (anti-tie down)
- The appropriate performance level of the safety-related function (Control Reliability, Category/Performance level, or appropriate regulation and standard, or Safety Integration Level) as determined by a risk assessment

**WARNING:**

- **Use adequate point-of-operation guarding**
- Failure to properly guard hazardous machinery can result in a dangerous condition that could lead to serious injury or death.
- When properly installed, a two-hand control safety device provides protection only for the hands of the machine operator. It might be necessary to install additional safeguarding, such as safety light curtains, additional two-hand controls, and/or hard guards, to protect all individuals from hazardous machinery.

**CAUTION:**

- **Avoid installing hand controls in contaminated environments**—Severe contamination or other environmental influences could cause a slow response or false on condition of mechanical or ergonomic buttons.
- A slow response or false on condition could result in exposure to a hazard.
- The environment in which hand controls are installed must not adversely affect the means of actuation.

The level of safety achieved (for example, ISO 13849-1 Category) depends in part on the circuit type selected.

Consider the following when installing hand controls:

- Failure modes, such as a short circuit, a broken spring, or a mechanical seizure, that may result in not detecting the release of a hand control
- Severe contamination or other environmental influences that may cause a slow response when released or false ON condition of the hand control(s), for example, sticking of a mechanical linkage
- Protection from accidental or unintended operation, for example, mounting position, rings, guards, or shields
- Minimizing the possibility of defeat, for example, hand controls must be far enough apart so that they cannot be operated by the use of one arm—typically, not less than 550 mm (21.7 in) in a straight line, per ISO 13851
- The functional reliability and installation of external logic devices
- Proper electrical installation per NEC and NFPA 79 or IEC 60204

**CAUTION:**

- **Install hand controls to prevent accidental actuation**
- It is not possible to completely protect the two-hand control system from defeat.
- OSHA regulations require the user to arrange and protect hand controls to minimize possibility of defeat or accidental actuation.

**CAUTION:**

- **Machine control must provide anti-repeat control**
- U.S. and International standards for single-stroke or single-cycle machines require that the machine control provides appropriate anti-repeat control.
- This Banner Engineering device can assist in accomplishing anti-repeat control, but a risk assessment must be performed to determine the suitability of such use.

Two-Hand Control Safety Distance (Minimum Distance)

Install all hand controls far enough away from the nearest hazard point that the operator cannot reach the hazard with a hand or other body part before the hazardous motion ceases. This is the separation distance (safety distance), and may be calculated as follows.

**WARNING:**

- **Mount hand controls at a safe distance from moving machine parts**
- Failure to establish and maintain the safety distance (minimum distance) could result in serious injury or death.
- Mount hand controls as determined by the applicable standard. The operator or other non-qualified persons must not be able to relocate the hand controls.

U.S. Applications

The Safety Distance formula, as provided in ANSI B11.19:

Part-Revolution Clutch Machinery (the machine and its controls allow the machine to stop motion during the hazardous portion of the machine cycle)

$$D_s = K \times (T_s + T_r) + D_{p\epsilon}$$

For Full-Revolution Clutch Machinery (the machine and its controls are designed to complete a full machine cycle)

$$D_s = K \times (T_m + T_r + T_h)$$

D_s

the Safety Distance (in inches)

K

the OSHA/ANSI recommended hand-speed constant (in inches per second), in most cases is calculated at 63 in/s, but may vary between 63 in/s to 100 in/s based on the application circumstances;
not a conclusive determination; consider all factors, including the physical ability of the operator, when determining the value of K to be used.

T_h

the response time of the slowest hand control from the time when a hand disengages that control until the switch opens;

T_h is usually insignificant for purely mechanical switches. However, T_h should be considered for safety distance calculation when using electronic or electromechanical (powered) hand controls.

For Banner Engineering Self-checking Touch Buttons (STBs) the response time is 0.02 seconds.

T_m

the maximum time (in seconds) the machine takes to cease all motion after it has been tripped. For full revolution clutch presses with only one engaging point, T_m is equal to the time necessary for one and one-half revolutions of the crankshaft. For full revolution clutch presses with more than one engaging point, T_m is calculated as follows:

$$T_m = (1/2 + 1/N) \times T_{cy}$$

N = number of clutch engaging points per revolution

T_{cy} = time (in seconds) necessary to complete one revolution of the crankshaft

T_r

the response time of the Safety Controller as measured from the time a stop signal from either hand control is received. The Safety Controller response time is obtained from the **Configuration Summary** tab in the Software.

T_s

the overall stop time of the machine (in seconds) from the initial stop signal to the final ceasing of all motion, including stop times of all relevant control elements and measured at maximum machine velocity.

T_s is usually measured by a stop-time measuring device. If the specified machine stop time is used, add at least 20% as a safety factor to account for brake system deterioration. If the stop-time of the two redundant machine control elements is unequal, the slower of the two times must be used for calculating the separation distance.

D_{pf}

Per ANSI B11.19, the adder to account for the distance that is possible for the individual to be reaching toward the hazard zone before a protective stop is initiated. For two-hand control applications where encroachment towards the hazard is not restricted, D_{pf} = 550 mm (21.65 in). When encroachment is obstructed (for example, shrouding the two-hand actuating controls, orientation of the work station, etc.), the reaching distance (d_{ds}) may be reduced to zero. D_{pf} is also known as "d_{ds}".

European Applications

The Minimum Distance Formula, as provided in EN 13855:

$$S = (K \times T) + C$$

S

the Minimum Distance (in millimeters)

K

the EN 13855 recommended hand-speed constant (in millimeters per second), in most cases is calculated at 1600 mm/s, but may vary between 1600 mm/s to 2500 mm/s based on the application circumstances;

not a conclusive determination; consider all factors, including the physical ability of the operator, when determining the value of K to be used.

T

the overall machine stopping response time (in seconds), from the physical initiation of the safety device to the final ceasing of all motion.

C

the added distance due to the depth penetration factor equals 250 mm, per EN 13855. ISO/DIS 13855:2022 increases the C factor (d_{ds}) to 550 mm. The EN 13855 **C** factor may be reduced to 0 if the risk of encroachment is eliminated, but the safety distance must always be 100 mm or greater.

7.5.9 Safety Mat

The Safety Controller may be used to monitor pressure-sensitive safety mats and safety edges.

The purpose of the Safety Mat input of the Safety Controller is to verify the proper operation of 4-wire, presence-sensing safety mats. Multiple mats may be connected in series to one Safety Controller, 150 ohms maximum per input (see [Safety Mat Hookup Options](#) on page 46).



Important: The Safety Controller is not designed to monitor 2-wire mats, bumpers, or edges (with or without sensing resistors).

The Safety Controller monitors the contacts (contact plates) and the wiring of one or more safety mat(s) for failures and prevents the machine from restarting if a failure is detected. A reset routine after the operator steps off the safety mat may be provided by the Safety Controller, or, if the Safety Controller is used in auto-reset mode, the reset function must be provided by the machine control system. This prevents the controlled machinery from restarting automatically after the mat is cleared.



WARNING:

- **Application of Safety Mats**
- Failure to follow these instructions could result in serious injury or death.
- Safety Mat application requirements vary for the level of control reliability or category and performance level as described by ISO 13849-1 and ISO 13856. Although Banner Engineering always recommends the highest level of safety in any application, the user is responsible to safely install, operate, and maintain each safety system per the manufacturer's recommendations and comply with all relevant laws and regulations.
- Do not use safety mats as a tripping device to initiate machine motion (such as in a presence-sensing device initiation application), because of the possibility of unexpected start or re-start of the machine cycle resulting from failure(s) within the mat and the interconnect cabling.
- Do not use a safety mat to enable or provide the means to allow the machine control to start hazardous motion by simply standing on the safety mat (for example, at a control station). This type of application uses reverse/negative logic and certain failures (for example, loss of power to the Module) can result in a false enable signal.

Safety Mat Requirements

The following are minimum requirements for the design, construction, and installation of four-wire safety mat sensor(s) to be interfaced with the Safety Controller. These requirements are a summary of standards ISO 13856-1, ANSI/RIA R15.06 and ANSI B11.19. The user must review and comply with all applicable regulations and standards.

Safety Mat System Design and Construction

The safety mat system sensor, Safety Controller, and any additional devices must have a response time that is fast enough to reduce the possibility of an individual stepping lightly and quickly over the mat's sensing surface (less than 100 to 200 ms, depending on the relevant standard).

For a safety mat system, the minimum object sensitivity of the sensor must detect, at a minimum, a 30 kg (66 lb) weight on an 80 mm (3.15 in) diameter circular disk test piece anywhere on the mat's sensing surface, including joints and junctions. The effective sensing surface or area must be identifiable and can comprise one or more sensors. The safety mat supplier should state this minimum weight and diameter as the minimum object sensitivity of the sensor.

User adjustments to actuating force and response time are not allowed (ISO 13856-1). The sensor should be manufactured to prevent any reasonably foreseeable failures, such as oxidation of the contact elements which could cause a loss in sensitivity.

The environmental rating of the sensor must meet a minimum of IP54. When the sensor is specified for immersion in water, the sensor's minimum enclosure level must be IP67. The interconnect cabling may require special attention. A wicking action may result in the ingress of liquid into the mat, possibly causing a loss of sensor sensitivity. The termination of the interconnect cabling may need to be located in an enclosure that has an appropriate environmental rating.

The sensor must not be adversely affected by the environmental conditions for which the system is intended. The effects of liquids and other substances on the sensor must be taken into account. For example, long-term exposure to some liquids can cause degradation or swelling of the sensor's housing material, resulting in an unsafe condition.

The sensor's top surface should be a lifetime non-slip design, or otherwise minimize the possibility of slipping under the expected operating conditions.

The four-wire connection between the interconnect cables and the sensor must withstand dragging or carrying the sensor by its cable without failing in an unsafe manner, such as broken connections due to sharp or steady pulls, or continuous flexing. If such connection is not available, an alternative method must be employed to avoid such failure, for example, a cable which disconnects without damage and results in a safe situation.

Safety Mat Installation

The mounting surface quality and preparation for the safety mat must meet the requirements stated by the manufacturer of the sensor. Irregularities in the mounting surfaces may impair the function of the sensor and should be reduced to an acceptable minimum. The mounting surface should be level and clean. Avoid the collection of fluids under or around the sensor. Prevent the risk of failure due to a build-up of dirt, turning chips, or other material under the sensor(s) or the associated hardware. Special consideration should be given to joints between the sensors to ensure that foreign material does not migrate under or into the sensor.

Any damage (cuts, tears, wear, or punctures) to the outer insulating jacket of the interconnect cable or to any part of the exterior of the safety mat must be immediately repaired or replaced. Ingress of material (including dirt particles, insects, fluid, moisture, or turning-chips), which may be present near the mat, may cause the sensor to corrode or to lose its sensitivity.

Routinely inspect and test each safety mat according to the manufacturer's recommendations. Do not exceed operational specifications, such as the maximum number of switching operations.

Securely mount each safety mat to prevent inadvertent movement (creeping) or unauthorized removal. Methods include, but are not limited to, secured edging or trim, tamper-resistant or one-way fasteners, and recessed flooring or mounting surface, in addition to the size and weight of large mats.

Each safety mat must be installed to minimize tripping hazards, particularly towards the machine hazard. A tripping hazard may exist when the difference in height of an adjacent horizontal surface is 4 mm (1/8 in) or more. Minimize tripping hazards at joints, junctions, and edges, and when additional coverings are used. Methods include a ground-flush installation of the mat, or a ramp that does not exceed 20° from horizontal. Use contrasting colors or markings to identify ramps and edges.

Position and size the safety mat system so that persons cannot enter the hazardous area without being detected, and cannot reach the hazard before the hazardous conditions have ceased. Additional guards or safeguarding devices may be required to ensure that exposure to the hazard(s) is not possible by reaching over, under, or around the device's sensing surface.

A safety mat installation must take into account the possibility of easily stepping over the sensing surface and not being detected. ANSI and international standards require a minimum depth of field of the sensor surface (the smallest distance between the edge of the mat and hazard) to be from 750 mm to 1200 mm (30 in to 48 in), depending on the application and the relevant standard. The possibility of stepping on machine supports or other physical objects to bypass or climb over the sensor also must be prevented.

Safety Mat Safety Distance (Minimum Distance)

As a stand-alone safeguard, the safety mat must be installed at a safety distance (minimum distance) so that the exterior edge of the sensing surface is at or beyond that distance, unless it is solely used to prevent start/restart, or solely used for clearance safeguarding (see ANSI B11.19, ANSI/RIA R15.06, and ISO 13855).

The safety distance (minimum distance) required for an application depends on several factors, including the speed of the hand (or individual), the total system stopping time (which includes several response time components), and the depth penetration factor. Refer to the relevant standard to determine the appropriate distance or means to ensure that individuals cannot be exposed to the hazard(s).

Figure 24. Determining safety distance for the safety mat

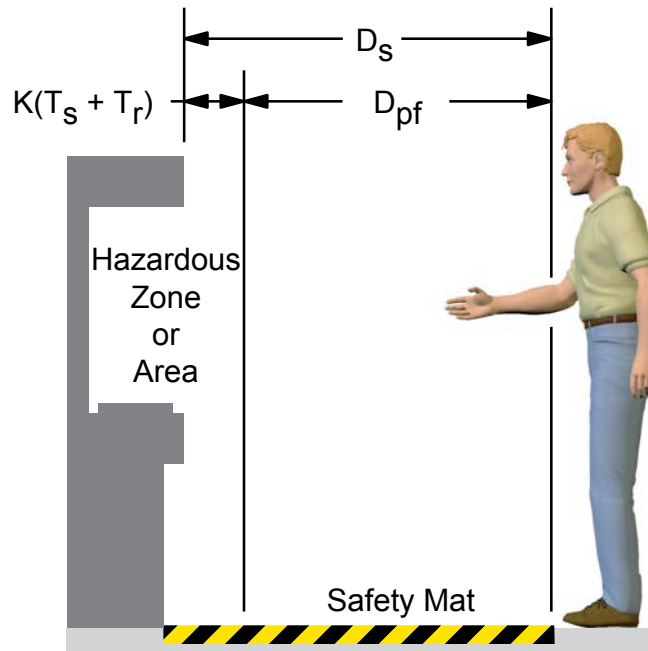

U.S. Applications

The Safety Distance formula, as provided in ANSI B11.19:

$$D_s = K \times (T_s + T_r) + D_{pf}$$

D_s

the Safety Distance (in inches)

T_r

the response time of the Safety Controller as measured from the time a stop signal from either hand control. The Safety Controller response time is obtained from the **Configuration Summary** tab in the Software.

K

the OSHA/ANSI recommended hand-speed constant (in inches per second), in most cases is calculated at 63 in/s, but may vary between 63 in/s to 100 in/s based on the application circumstances; not a conclusive determination; consider all factors, including the physical ability of the operator, when determining the value of K to be used.

T_s

the overall stop time of the machine (in seconds) from the initial stop signal to the final ceasing of all motion, including stop times of all relevant control elements and measured at maximum machine velocity.

T_s is usually measured by a stop-time measuring device. If the specified machine stop time is used, add at least 20% as a safety factor to account for brake system deterioration. If the stop-time of the two redundant machine control elements is unequal, the slower of the two times must be used for calculating the separation distance.

D_{pf}

the added distance due to the penetration depth factor equals 48 in, per ANSI B11.19

European Applications

The Minimum Distance Formula, as provided in EN 13855:

$$s = (K \times T) + c$$

S

the Minimum Distance (in millimeters)

K

the EN 13855 recommended hand-speed constant (in millimeters per second), in most cases is calculated at 1600 mm/s, but may vary between 1600 mm/s to 2500 mm/s based on the application circumstances; not a conclusive determination; consider all factors, including the physical ability of the operator, when determining the value of K to be used.

T

the overall machine stopping response time (in seconds), from the physical initiation of the safety device to the final ceasing of all motion.

C

the added distance due to the depth penetration factor equals 1200 mm, per EN 13855.

Safety Mat Hookup Options

Pressure-sensitive mats and pressure-sensitive floors must meet the requirements of the category for which they are specified and marked. These categories are defined in ISO 13849-1.

The safety mat, its Safety Controller, and any output signal switching devices must meet, at a minimum, the Category 1 safety requirements. See ISO 13856-1 and ISO 13849-1 for relevant requirement details.

The Safety Controller is designed to monitor 4-wire safety mats and is not compatible with two-wire devices (mats, sensing edges, or any other devices with two wires and a sensing resistor).

4-Wire

This circuit typically meets ISO 13849-1 Category 2 or Category 3 requirements depending on the safety rating and installation of the mat(s). The Safety Controller enters a Lockout mode when an open wire, a short to 0 V, or a short to another source of power is detected.



7.5.10 Muting Sensor

Safety device muting is an automatically controlled suspension of one or more safety input stop signals during a portion of a machine operation when no immediate hazard is present or when access to the hazard is safeguarded. Muting sensors can be mapped to one or more of the following safety input devices:

- Safety gate (interlocking) switches
- Optical sensors
- Two-hand controls
- Safety mats
- Protective stops

US and International standards require the user to arrange, install, and operate the safety system so that personnel are protected and the possibility of defeating the safeguard is minimized.

Examples of Muting Sensors and Switches



WARNING:

- **Avoid hazardous installations**
- Improper adjustment or positioning could result in serious injury or death.
- Properly adjust or position the two or four independent position switches so that they close only after the hazard no longer exists and open again when the cycle is complete or the hazard is again present.
- The user is responsible for satisfying all local, state, and national laws, rules, codes, and regulations relating to the use of safety equipment in any particular application. Ensure that all appropriate agency requirements have been met and that all installation and maintenance instructions contained in the appropriate manuals are followed.

Photoelectric Sensors (Opposed Mode)

Opposed-mode sensors should be configured for dark operate (DO) and have open (non-conducting) output contacts in a power Off condition. Both the emitter and receiver from each pair should be powered from the same source to reduce the possibility of common mode failures.

Photoelectric Sensors (Polarized Retroreflective Mode)

The user must ensure that false proxying (activation due to shiny or reflective surfaces) is not possible. Banner Engineering low profile sensors with linear polarization can greatly reduce or eliminate this effect.

Use a sensor configured for light operate (LO or NO) if initiating a mute when the retroreflective target or tape is detected (home position). Use a sensor configured for dark operate (DO or NC) when a blocked beam path initiates the muted condition (entry/exit). Both situations must have open (non-conducting) output contacts in a power Off condition.

Positive-Opening Safety Switches

Two (or four) independent switches, each with a minimum of one closed safety contact to initiate the mute cycle, are typically used. An application using a single switch with a single actuator and two closed contacts may result in an unsafe situation.

Inductive Proximity Sensors

Typically, inductive proximity sensors are used to initiate a muted cycle when a metal surface is detected. Do not use two-wire sensors due to excessive leakage current causing false On conditions. Use only three- or four-wire sensors that have discrete PNP or hard-contact outputs that are separate from the input power.

Mute Device Requirements

The muting devices must, at a minimum, comply with the following requirements:

1. There must be a minimum of two independent hard-wired muting devices.
2. The muting devices must have one of the following: normally open contacts, PNP outputs (both of which must fulfill the input requirements listed in the [Specifications and Requirements](#) on page 20), or a complementary switching action. At least one of these contacts must close when the switch is actuated, and must open (or not conduct) when the switch is not actuated or is in a power-off state.
3. The activation of the inputs to the muting function must come from separate sources. These sources must be mounted separately to prevent an unsafe muting condition resulting from misadjustment, misalignment, or a single common mode failure, such as physical damage to the mounting surface. Only one of these sources may pass through, or be affected by, a PLC or a similar device.
4. The muting devices must be installed so that they cannot be easily defeated or bypassed.
5. The muting devices must be mounted so that their physical position and alignment cannot be easily changed.
6. It must not be possible for environmental conditions, such as extreme airborne contamination, to initiate a mute condition.
7. The muting devices must not be set to use any delay or other timing functions unless such functions are accomplished so that no single component failure prevents the removal of the hazard, subsequent machine cycles are prevented until the failure is corrected, and no hazard is created by extending the muted period.

7.5.11 Bypass Switch

The safety device bypass is a manually activated and temporary suspension of one or more safety input stop signals, under supervisory control, when no immediate hazard is present. It is typically accomplished by selecting a bypass mode of operation using a key switch to facilitate machine setup, web alignment/adjustments, robot teach, and process troubleshooting.

Bypass switches can be mapped to one or more of the following safety input devices:

- Safety gate (interlocking) switches
- Optical sensors
- Two-Hand Controls
- Safety mats
- Protective stop

Requirements of Bypassing Safeguards

Requirements to bypass a safeguarding device include ¹¹:

- The bypass function must be temporary
- The means of selecting or enabling the bypass must be capable of being supervised
- Automatic machine operation must be prevented by limiting range of motion, speed, or power (use inch, jog, or slow-speed modes). Bypass mode must not be used for production
- Supplemental safeguarding must be provided. Personnel must not be exposed to hazards
- The means of bypassing must be within full view of the safeguard to be bypassed
- Initiation of motion should only be through a hold-to-run type of control
- All emergency stops must remain active
- The means of bypassing must be employed at the same level of reliability as the safeguard
- Visual indication that the safeguarding device has been bypassed must be provided and be readily observable from the location of the safeguard

¹¹ This summary was compiled from sources including NFPA79, ANSI/RIA R15.06, ISO 13849-1, IEC60204-1, and ANSI B11.19. The user is responsible to verify safeguards required by these specs and all other relevant laws and regulations.

- Personnel must be trained in the use of the safeguard and in the use of the bypass
- Risk assessment and risk reduction (per the relevant standard) must be accomplished
- The reset, actuation, clearing, or enabling of the safeguarding device must not initiate hazardous motion or create a hazardous situation

Bypassing a safeguarding device should not be confused with *muting*, which is a temporary, automatic suspension of the safeguarding function of a safeguarding device during a non-hazardous portion of the machine cycle. Muting allows for material to be manually or automatically fed into a machine or process without issuing a stop command. Another term commonly confused with bypassing is *blanking*, which desensitizes a portion of the sensing field of an optical safeguarding device, such as disabling one or more beams of a safety light curtain so that a specific beam break is ignored.

7.5.12 Adjustable Valve Monitoring (AVM) Function

The Adjustable Valve (Device) Monitoring (AVM) function is similar in function to One-Channel External Device Monitoring (1-channel EDM, see [External Device Monitoring \(EDM\)](#) on page 70). The AVM function monitors the state of the device(s) that are controlled by the safety output to which the function is mapped. When the safety output turns OFF, the AVM input must be high/On (+24 V DC applied) before the AVM timer expires or a lockout will occur. The AVM input must also be high/ON when the safety output attempts to turn ON or a lockout will occur.

Figure 25. Timing logic—AVM Function

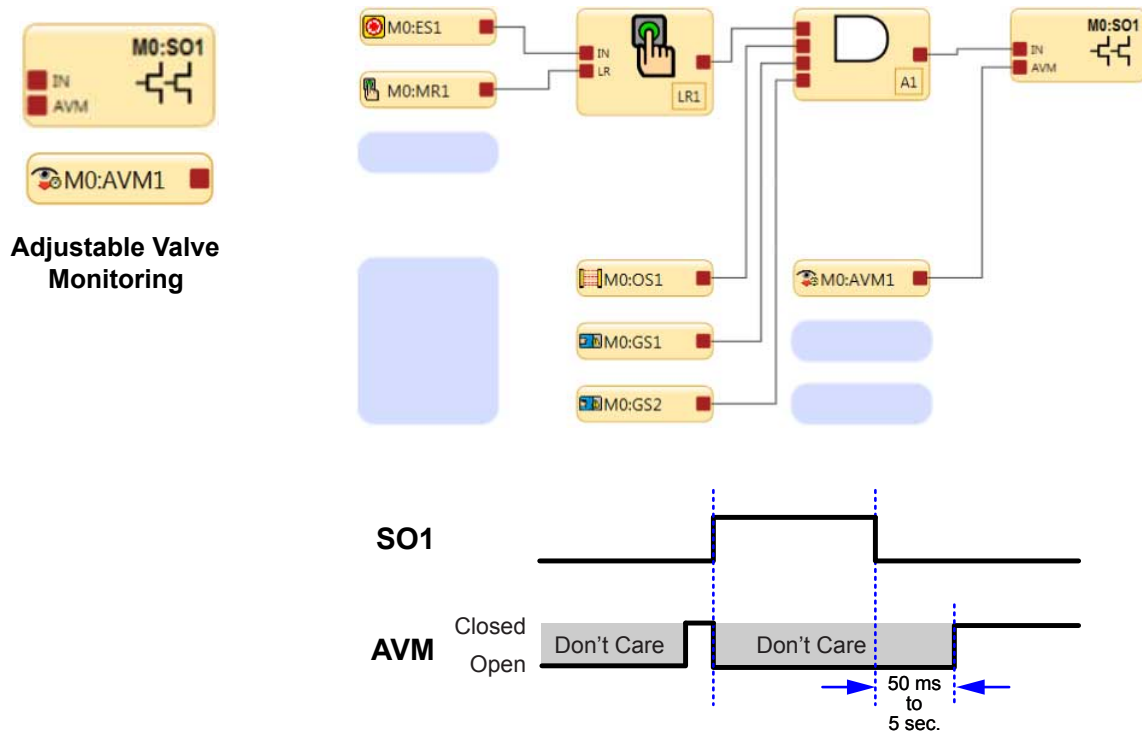

Adjustable Valve Monitoring AVM is a way to check the operation of dual-channel valves. The force guided NC monitoring contacts of the valves are used as an input to detect a “stuck on” fault condition and will prevent the Safety Controller outputs from turning On.



Note: 50 ms to 5 s time period is adjustable in 50 ms intervals (default is 50 ms).

The Adjustable Valve (Device) Monitoring function is useful for dynamically monitoring devices under the control of the safety output that may become slow, stick, or fail in an energized state or position, and whose operation needs to be verified after a Stop signal occurs. Example applications include single- or dual-solenoid valves controlling clutch/brake mechanisms, and position sensors that monitor the home position of a linear actuator.

Synchronization or checking a maximum differential timing between two or more devices, such as dual valves, may be achieved by mapping multiple AVM functions to one safety output and configuring the AVM timer to the same values. Any number of AVM inputs can be mapped to one safety output. An input signal can be generated by a hard/relay contact or a solid-state PNP output.

**WARNING:**

- **Adjustable Valve Monitoring (AVM) Operation**
- When the AVM function is used, the Safety Output(s) will not turn ON until the AVM input is satisfied. This could result in an ON-delay up to the configured AVM monitoring time.
- It is the user's responsibility to ensure the AVM monitoring time is properly configured for the application and to instruct all individuals associated with the machine about the possibility of the ON-Delay effect, which may not be readily apparent to the machine operator or to other personnel.

7.5.13 ISD Inputs

ISD inputs are available on SC10-2 and XS26-ISD models.

The SC10 safety inputs

- IN3/IN4
- IN5/IN6

and the XS26-ISD safety inputs

- IN1/IN2
- IN3/IN4
- IN5/IN6
- IN7/IN8
- IN9/IN10
- IN11/IN12
- IN13/IN14
- IN15/IN16

may be used to monitor chains of devices with embedded In-Series Diagnostic (ISD) data, such as the Banner SI-RFD Safety Switches, the Banner Lighted Emergency Stop Buttons with ISD, or the Banner ISD Connect. The Banner SI-RFD Safety Switches use RFID technology as a means of detection.

ISD-enabled devices have a maximum cable run of 30 meters between devices and from the last device to the controller.



Note: The safety controller's response is based on the state of the output signal switching devices (OSSDs) of the ISD inputs, not the ISD information carried on the OSSDs. The ISD information is non-safety chain/device status information.

ISD devices, such as SI-RFD Safety Switches, must be placed at an appropriate safety distance (minimum distance), according to the application standards. Refer to the applicable standards and to the documentation specific to the device for the appropriate calculations. The response time of the Safety Controller outputs to each safety input is provided on the **Configuration Summary** tab in the Software. This time must be added to the response time of the ISD chain of devices. See the individual ISD device manuals to determine the response time of the ISD chain.

The active ISD devices' solid-state outputs have (and must have) the ability to detect external shorts to power, to ground, or to each other. The devices will lockout if such a short is detected.

If the application includes a pass-through hazard (a person could pass through an opened gate and stand undetected on the hazard side), other safeguarding may be required, and manual reset should be selected. See [Manual Reset Input](#) on page 59.

**WARNING:**

- Configuration Conforms to Applicable Standards
- Failure to verify the application may result in serious injury or death.
- The Banner Safety Controller Software primarily checks the logic configuration for connection errors. The user is responsible for verifying the application meets the risk assessment requirements and that it conforms to all applicable standards.
- The user is responsible to wire the ISD chain to match the configuration; errors in the chain length and/or order are only reported via Ethernet (input still seen as ON).



Important: The machine builder (user) is responsible to ensure the wiring/cabling is not easily manipulated by an operator to defeat the safety function(s). For example, the operator cannot remove a device from the system.



Note: In a long chain or chains with a lot of ISD devices, the voltage at the first unit (closest to the terminating plug) must stay above 19.5 volts for the chain to operate properly.



Note: The Banner Safety Controller Software applies the gate switch rules to the ISD Inputs.

Request Performance and Status Information about an Individual Device via ISD

Use the following procedure to get performance and status information about an individual ISD device using ISD.

1. Change the ISD Chain Requested register to match the ISD chain number for the device in question (1 or 2).
2. Change the ISD Device Requested register to match the ISD device number for the device in question (1 to 32).
3. Change the ISD Read Request register from 0 to 1 to perform a one-time read.
4. Observe the ISD Individual Device-Specific Data register array to read the desired device data.

Request Device List and Re-baseline an ISD Chain via ISD

Use the following procedure to get a list of the ISD devices in order from a chain and to reset the baseline.

1. Enter the desired Chain number into the ISD Chain Requested register (1–8).
2. Enter 2 into the ISD Read Request register.

When the ISD Read Request Acknowledge register also reads 2, the process is complete. An array of 32 bytes is provided in the List of Detected ISD Devices on a Chain register block, giving the code for each ISD device, and a new device count, type, and order baseline is established.

Request Device List and Clear Count Change Flag in an ISD Chain via ISD

Use the following procedure to get a list of the ISD devices in order from a chain and to clear the Count Change flag.

1. Enter the desired Chain number into the ISD Chain Requested register (1–8).
2. Enter 4 into the ISD Read Request register.

When the ISD Read Request Acknowledge register also reads 4, the process is complete. An array of 32 bytes is provided in the List of Detected ISD Devices on a Chain register block, giving the code for each ISD device.



Note: This does not establish a new baseline.

ISD Chain System Status

Banner Engineering has created a couple of words that can be accessed quickly by the PLC to indicate if there are any problems with the ISD chain.



Note: The ISD data is not immediately available upon power up. The ISD data can be delayed up to 10 seconds after the system power has been turned on.

This information has the following format:

Information	Type	Data Size	Steps to Resolve
ISD chain count does not match configuration ¹²	Controller Alert	1 bit	Check the number of physical units against the number configured in the chain
ISD chain order does not match configuration ¹²	Controller Alert	1 bit	Check the order of the physical units against the configured order. Note the location of the terminator plug and the controller.
ISD data update pending (no data or buffered data)	Controller Alert	1 bit	Caused by non-ISD devices in chain or a buffering situation If the data is not present from power up (never present): <ul style="list-style-type: none"> • Verify that all devices in ISD Chain are ISD enabled devices If data was present but then lost: <ul style="list-style-type: none"> • Verify that the chain has not been broken • Data could be disrupted and will return in a few seconds
Invalid (non-ISD) device in ISD chain	Controller Alert	1 bit	Incorrect data types are being received <ul style="list-style-type: none"> • Verify that all devices in the chain are Banner ISD devices

¹² XS26-ISD FID 5 or later (only when not using Auto Detect mode) and SC10 FID 2 or later.

Information	Type	Data Size	Steps to Resolve
ISD device detected but not configured (<i>reserved</i> in XS26-ISD)	Informative	1 bit	<ul style="list-style-type: none"> Verify the ISD chain is wired to the correct terminals Verify that the correct input device type (ISD) was selected for this input in the configuration.
ISD chain terminator plug missing	ISD Status	1 bit	<ul style="list-style-type: none"> Verify that the terminator plug has not come loose Verify that the chain has not been broken (loose connections)
SI-RF high or unique sensor not taught an actuator	ISD Fault	1 bit	<p>An SI-RF switch (-UP8 or -HP8) have not been taught</p> <ul style="list-style-type: none"> Configure the unit to its actuator per instructions in Banner datasheet p/n 208885
Wrong actuator presented to a high or unique sensor	ISD Fault	1 bit	<p>An SI-RF switch (-UP8 or -HP8) is seeing an actuator but not the one to which it was configured.</p> <ul style="list-style-type: none"> Check for tampering (wrong actuator being used) Teach High coded sensor (-HP8) the new actuator
Internal error on an ISD device in the chain	ISD Fault	1 bit	<ul style="list-style-type: none"> Verify which device has the error, cycle power to the system If the error persists, replace the device
ISD Output fault detected, output turn off counter started	ISD Fault	1 bit	<p>ISD device output will turn off in 20 minutes</p> <ul style="list-style-type: none"> Verify which device has the error, check wiring for shorts Cycle power, if issue persists, replace the device
Change in ISD chain detected (only in XS26-ISD FID 5 or later)	ISD Status	1 bit	<p>If AutoDetect ISD is configured and an ISD chain length or order has changed, this flag will be set and must be recognized by the PLC.</p> <p>See Request Device List and Re-baseline an ISD Chain via ISD on page 50.</p>
ISD Count Change from Baseline Detected	ISD Status	1 bit	<p>ISD device count has changed from the baseline count, verify the chain device count matches machine configuration.</p> <p>See Request Device List and Clear Count Change Flag in an ISD Chain via ISD on page 50.</p>
ISD Chain output signal switching device (OSSD) status	ISD Status	1 bit	

ISD Individual Device-Specific Data



Note: The ISD data is not immediately available upon power up. The ISD data can be delayed up to 10 seconds after the system power has been turned on.

Information	Data size	Applies to Banner Device (Y/N/Reserved)		
		SI-RF	E-Stop	ISD Connect
Safety Input Fault	1 bit	Y	Y	Y
<i>reserved</i>	1 bit	<i>reserved</i>	<i>reserved</i>	<i>reserved</i>

Information	Data size	Applies to Banner Device (Y/N/Reserved)		
		SI-RF	E-Stop	ISD Connect
Sensor Not Paired	1-bit	Y	N	N
ISD Data Error	1-bit	Y	Y	Y
Wrong Actuator/Button Status/Input Status	1-bit	Y	Y	Y
Marginal Range/Button Status/Input Status	1-bit	Y	Y	Y
Actuator Detected	1-bit	Y	N	N
Output Error	1-bit	Y	Y	Y
Input 2	1-bit	Y	Y	Y
Input 1	1-bit	Y	Y	Y
Local Reset Expected	1-bit	Y	Y	N
Operating Voltage Warning	1-bit	Y	Y	Y
Operating Voltage Error	1-bit	Y	Y	Y
Output 2	1-bit	Y	Y	Y
Output 1	1-bit	Y	Y	Y
Power Cycle Required	1-bit	Y	Y	Y
Fault Tolerant Outputs	1-bit	Y	Y	Y
Local Reset Unit	1-bit	Y	Y	N
Cascadable	1-bit	Y	Y	Y
High Coding Level	1-bit	Y	N	N
Teach-ins Remaining	4-bit	Y	N	N
Device ID	5-bit	Y	Y	Y
Range Warning Count	6-bit	Y	N	N
Output Switch-off Time	5-bit	Y	Y	Y
Number of Voltage Errors	8-bit	Y	Y	Y
Internal Temperature ¹³	8-bit	Y	Y	Y
Actuator Distance ¹³	8-bit	Y	N	N
Supply Voltage ¹³	8-bit	Y	Y	Y
Expected Company Name	4-bit	Y	N (always "6")	N (always "6")
Received Company Name	4-bit	Y	N	N
Expected Code	16-bit	Y	N	N
Received Code	16-bit	Y	N	N
Internal Error A	16-bit	Y	Y	Y
Internal Error B	16-bit	Y	Y	Y

¹³ For conversion to Internal Temperature, Actuator Distance, and Supply Voltage, see [ISD: Temperature, Voltage, and Distance Conversion Information](#) on page 296.

SI-RF Device

In the case of the ISD-enabled gate switch (SI-RF), the ISD Individual Device-Specific Data coming back from the SI-RF device has the following format:

Information	Data size
Safety Input Fault	1 bit
<i>reserved</i>	1 bit
Sensor Not Paired	1-bit
ISD Data Error	1-bit
Wrong Actuator	1-bit
Marginal Range	1-bit
Actuator Detected	1-bit
Output Error	1-bit
Input 2	1-bit
Input 1	1-bit
Local Reset Expected	1-bit
Operating Voltage Warning	1-bit
Operating Voltage Error	1-bit
Output 2	1-bit
Output 1	1-bit
Power Cycle Required	1-bit
Fault Tolerant Outputs	1-bit
Local Reset Unit	1-bit
Cascadable	1-bit
High Level Coding	1-bit
Teach-ins Remaining	4-bit
Device ID	5-bit
Range Warning Count	6-bit
Output Switch-off Time	5-bit (value of 31 means Timer is OFF)
Number of Voltage Errors	8-bit
Internal Temperature ¹⁴	8-bit
Actuator Distance ¹⁴	8-bit
Supply Voltage ¹⁴	8-bit
Expected Company Name	4-bit
Received Company Name	4-bit
Expected Code	16-bit
Received Code	16-bit
Internal Error A	16-bit
Internal Error B	16-bit

¹⁴ For conversion to Internal Temperature, Actuator Distance, and Supply Voltage, see [ISD: Temperature, Voltage, and Distance Conversion Information](#) on page 296.

E-Stop Device and ISD Connect

In the case of the ISD-enabled E-stop or ISD Connect, the ISD Individual Device-Specific Data coming back from the device has the following format:

Information	Data size
Safety Input Fault	1-bit
<i>reserved</i>	2-bit
ISD Data Error	1-bit
<i>reserved</i>	3-bit
Output Error	1-bit
Input 2	1-bit
Input 1	1-bit
Local Reset Expected	1-bit (always false for ISD Connect)
Operating Voltage Warning	1-bit
Operating Voltage Error	1-bit
Output 2	1-bit
Output 1	1-bit
Power Cycle Required	1-bit
Fault Tolerant Outputs	1-bit (always true for ISD E-Stop and Connect)
Local Reset Unit	1-bit (always false for ISD Connect)
Cascadable	1-bit (always true for ISD E-Stop and Connect)
<i>reserved</i>	5-bit
Device ID	5-bit (always value of 7 for ISD E-Stop) (always value of 9 for ISD Connect)
<i>reserved</i>	6-bit
Output Switch-off Time	5-bit (value of 31 means Timer is OFF)
Number of Voltage Errors	8-bit
Internal Temperature ¹⁵	8-bit
<i>reserved</i>	8-bit
Supply Voltage ¹⁵	8-bit
Expected Company Name	4-bit (always value of 6 for ISD E-Stop and Connect)
<i>reserved</i>	36-bit
Internal Error A	16-bit
Internal Error B	16-bit

¹⁵ For conversion to Internal Temperature, Actuator Distance, and Supply Voltage, see [ISD: Temperature, Voltage, and Distance Conversion Information](#) on page 296.

7.5.14 Cycle Initiation for Press Control Function Block

This feature is available on XS/SC26 FID 4 and later.

A single, momentary actuator may be used as an initiation device for small hydraulic/pneumatic presses when used with the Press Control Function Block when configured for Single Actuator Control. This is an initiation input to start the press cycle. When Single Actuator Control is selected, the operator can start the cycle with this input, and then release and perform other tasks.



CAUTION: Other means must be provided to ensure that operators are protected from the hazards because their hands do not have to engage the button during the entire movement of the press.

Access to the hazard must be protected using means other than a hold-to-run button, for example, light curtains, gates, etc. These safety devices must also be connected to inputs on the Press Control function block.

The Cycle Initiation input can be connected to the GO node of the Press Control Function Block or the IN node of a Bypass block that is connected to the GO node of the Press Control Function Block.

The Cycle Initiation device must be mounted at a location that complies with the following warning.



WARNING:

- **Install cycle initiation devices properly**
- Failure to properly install cycle initiation devices could result in serious injury or death.
- Install cycle initiation devices so that they are accessible only from outside, and in full view of, the safeguarded space. Cycle initiation devices cannot be accessible from within the safeguarded space. Protect cycle initiation devices against unauthorized or inadvertent operation (for example, through the use of rings or guards). If there are any hazardous areas that are not visible from the cycle initiation devices, provide additional safeguarding.

7.5.15 Press Control Sequential Stop (SQS) Function

This feature is available on XS/SC26 FID 4 and later.

The Press Control Sequential Stop (SQS) input provides a signal to the press control system that the press ram has reached a position such that there is no longer a crushing hazard (less than a 6 mm (0.25 in) gap). The downward motion of the press ram stops at this point. The operator can remove their hands from the two-hand control to ensure the work piece is in the correct position (the Mutable Safety input is muted at this time). After the operator ensures the work piece is in the correct position, they engage the Foot Switch input to finish the down stroke.



Note: The above is one method of controlling the Press Control process. There are three allowable processes:

1. Two-Hand Control input (TC1) turns on the GO input to drive the ram to the SQS point. Release TC1 and engage the FS1 to turn on the Ft Switch input to drive the ram to the Bottom of Stroke (BOS), release Foot Switch input (FS1) and engage TC1 to raise the ram.
2. FS1 turns on the GO input to drive the ram to the SQS point, Release FS1. Re-engaging FS1 drives the ram to the BOS point, and then back up to the Top of Stroke (TOS) point. (The Ft Switch input will disappear when FS1 is connected to the GO node).
3. TC1 turns on the GO input to drive the ram to the SQS point, release TC1. Re-engaging TC1 drives the ram to the BOS point, and then back up to the TOS point. (To set the system up for this method, do NOT select the Ft Switch node in the Press Control Inputs function block.)



Note: The Sequential Stop input is typically used with Dual Pressure selected. The Dual Pressure feature requires four safety outputs (up, down, low pressure, and high pressure). Because of this, the Sequential Stop input is not available on non-expandable models.

The Sequential Stop input can directly mute the Mutable Safety input or it can work in unison with the Press Control Mute Sensor input to mute the Mutable Safety input of the press control system (for Press Control Mute Sensor input, see [Press Control Mute Sensor](#) on page 56).

The Sequential Stop input can be a single-channel or dual-channel input depending on the requirements of the system. The input devices must be positioned to ensure that the press ram stops in a position that does not have a gap large enough that a finger can enter (must be a finger-safe gap of less than 6 mm/0.25 in).



Note: If a single-channel configuration is selected for the Sequential Stop input, it must work in unison with the Press Control Mute Sensor input to mute the Press Control Mutable Safety Stop input. If a dual-channel configuration is selected for the Sequential Stop input, it can directly mute the Press Control Mutable Safety Stop input by itself.

US and International standards require the user to arrange, install, and operate the safety system so that personnel are protected and the possibility of defeating the safeguard is minimized.

**WARNING:**

- Avoid Hazardous Installations
- A single-channel SQS device is not permitted unless it is used in conjunction with a Press Control Mute Sensor (PCMS) input device. When a two-channel SQS input is used without a PCMS, each SQS channel must be an independent position switch and must be properly adjusted or positioned so that they close only after the hazard no longer exists, and open again when the cycle is complete or the hazard is again present. If the switches are improperly adjusted or positioned, injury or death may result.
- The user is responsible to satisfy all local, state, and national laws, rules, codes, and regulations relating to the use of safety equipment in any particular application. Make sure that all appropriate agency requirements have been met and that all installation and maintenance instructions contained in the appropriate manuals are followed.

SQS Devices must, at a minimum, comply with the following requirements. If the SQS device is being used as a mute input with the Press Control Mute Sensor then the pair must comply with the following requirements.

1. There must be a minimum of two independent hard-wired devices.
2. The devices must have one of the following: normally open contacts, PNP outputs (both of which must fulfill the input requirements listed in [Specifications and Requirements](#) on page 20), or a complementary switching action. At least one of these contacts must close when the switch is actuated, and must open (or not conduct) when the switch is not actuated or is in a power-off state.
3. The activation of the inputs of this mute function must come from separate sources. These sources must be mounted separately to prevent an unsafe condition resulting from misadjustment, misalignment, or a single common mode failure, such as physical damage to the mounting surface. Only one of these sources may pass through, or be affected by, a PLC or similar device.
4. The devices must be installed so that they cannot be easily defeated or bypassed.
5. The devices must be mounted so that their physical position and alignment cannot be easily changed.
6. It must not be possible for environmental conditions, such as extreme airborne contamination, to initiate the mute condition.
7. The devices must not use any delay or other timing functions unless such functions are accomplished so that no single component failure prevents the removal of the hazard, subsequent machine cycles are prevented until the failure is corrected, and no hazard is created by extending the muted period.

7.5.16 Press Control Mute Sensor

This feature is available on XS/SC26 FID 4 and later.

Safety device muting is an automatically controlled suspension of the Mutable Safety Stop input of the Press Control function block during a portion of the press cycle when no immediate hazard is present or when access to the hazard is safeguarded by other means. Map the Press Control Mute Sensors to the M Sensor input of the Press Control Input Function Block to work with the Sequential Stop (SQS) input to mute one or more of the following safety input devices:

- Safety Gate (interlocking) switches
- Optical sensors
- Safety Mats
- Protective stops

US and International standards require the user to arrange, install, and operate the safety system so that personnel are protected and the possibility of defeating the safeguards is minimized.

**WARNING:**

- Avoid Hazardous Installations
- Two (1 SQS and 1 Press Control Mute Sensor) or four (2 SQS and 2 Press Control Mute Sensors) independent position switches must be properly adjusted or positioned so that they close only after the hazard no longer exists, and open again when the cycle is complete or the hazard is again present. If the switches are improperly adjusted or positioned, injury or death may result.
- The user is responsible to satisfy all local, state, and national laws, rules, codes, and regulations relating to the use of safety equipment in any particular application. Make sure that all appropriate agency requirements have been met and that all installation and maintenance instructions contained in the appropriate manuals are followed.

The Press Control Mute Sensor (with the SQS Device) must, at a minimum, comply with the following requirements:

1. There must be a minimum of two independent hard-wired devices.
2. The devices must have one of the following: normally open contacts, PNP outputs (both of which must fulfill the input requirements listed in [Specifications and Requirements](#) on page 20), or a complementary switching action. At least one of these contacts must close when the switch is actuated, and must open (or not conduct) when the switch is not actuated or is in a power-off state.
3. The activation of the inputs of this mute function must come from separate sources. These sources must be mounted separately to prevent an unsafe condition resulting from misadjustment, misalignment, or a single common mode failure, such as physical damage to the mounting surface. Only one of these sources may pass through, or be affected by, a PLC or similar device.
4. The devices must be installed so that they cannot be easily defeated or bypassed.
5. The devices must be mounted so that their physical position and alignment cannot be easily changed.
6. It must not be possible for environmental conditions, such as extreme airborne contamination, to initiate the mute condition.
7. The devices must not use any delay or other timing functions unless such functions are accomplished so that no single component failure prevents the removal of the hazard, subsequent machine cycles are prevented until the failure is corrected, and no hazard is created by extending the muted period.

7.5.17 Foot Switch

This feature is available on XS/SC26 FID 4 and later.

The Foot Switch input (FS1) can be used with the Press Control function blocks in a number of ways:

- It can be connected to the GO node of the Press Control function block as a cycle initiation device when the block is set for Single Actuator Control.
- It can be connected to the GO node of the Press Control function block when configured for the Manual Upstroke Setting and the SQS input is enabled. (Engaging the FS1 input drives the RAM to the SQS point. At this time, the FS1 is released. Because the Mutable Safety Stop input is now muted, the operator can adjust the workpiece. Engaging the FS1 again drives the ram to the BOS point then back up to the TOS point.)
- It can be used as described in the following paragraph.

The Foot Switch input can be added to the Press Control Input function block and configured when the SQS input is configured. The press stops at the SQS input, allowing the operator to remove their hands from the Two-Hand Control input. The operator can ensure that the work piece is positioned properly and sometimes needs to hold the work piece in position. The operator can then engage the input device connected to the Foot Switch input to re-engage the press to finish the process.

The Foot Switch input can also be configured to the Press GO node. In that case, the Foot Switch can be used with and without SQS being configured. This allows for more flexibility in use cases.

A physical on/off input or a Foot Switch input can be connected to the Ft Switch input of the Press Control Input function block. The device can be a foot switch but can also be other initiation devices.

Access to the hazard must be prevented using other means than the Mutable Safety Stop input device (for example, the internal opening must be finger-safe, less than 6 mm/0.25 in). Protection can also be provided by safety devices connected to the non-mutable Safety Stop input.



CAUTION: Other means must be provided to ensure that operators are protected from the hazards because their hands do not have to engage the button during this final movement of the press. The input can be single- or dual-channel (2 NO or 1 NO/1 NC).

7.6 Non-Safety Input Devices

The non-safety input devices include manual reset devices, ON/OFF switches, mute enable devices, and cancel delay inputs.

Manual Reset Devices

Used to create a reset signal for an output or function block configured for a manual reset, requiring an operator action for the output of that block to turn on. Resets can also be created using virtual reset input; see [Virtual Non-Safety Input Devices](#) on page 60.



WARNING:

- **Non-monitored resets**
- Failure to follow these instructions could result in serious injury or death.
- If a non-monitored reset (either latch or system reset) is configured and if all other conditions for a reset are in place, a short from the reset terminal to +24 V will turn on the safety output(s) immediately.

ON/OFF Switch

Provides an ON or OFF command to the machine. When all controlling safety inputs are in the Run state, this function permits the safety output to turn ON and OFF. This is a single-channel signal; the Run state is 24 V DC and the Stop state is 0 V DC. An ON/OFF input can be added without mapping to a safety output, which allows this input to control only a status output. An ON/OFF switch can also be created using a virtual input; see [Virtual Non-Safety Input Devices](#) on page 60.

XS/SC26 FID 4 or later: The ON/OFF inputs are used to select the mode of the Press Control Mode function block. Three separate inputs are required to satisfy this block. The block does accept Virtual ON/OFF inputs.

Mute Enable Switch

Signals the Safety Controller when the mute sensors are permitted to perform a mute function. When the mute enable function is configured, the mute sensors are not enabled to perform a mute function until the mute enable signal is in the Run state. This is a single-channel signal; the enable (Run) state is 24 V DC and the disable (Stop) state is 0 V DC. A mute enable switch can also be created using a virtual input; see [Virtual Non-Safety Input Devices](#) on page 60.

Cancel OFF-Delay Devices

Provide the option to cancel a configured OFF-delay time of a safety output or a delay block output, or to cancel a configured One Shot time of a one shot block output. It functions in one of the following ways:

- Keeps the safety output or delay block output ON
- Turns the safety output, delay block output, or one shot block output OFF immediately after the Safety Controller receives a Cancel OFF-Delay signal
- When **Cancel Type** is set to **Control Input**, the safety output or delay block output stays on if the input turns ON again before the end of the delay (does not apply to a One Shot block output)

A status output function (Output Delay in Progress) indicates when a Cancel Delay Input can be activated to keep the OFF-delayed safety output ON. A cancel OFF-delay device can also be created using a virtual input; see [Virtual Non-Safety Input Devices](#) on page 60.

Cancel OFF-Delay Timing

Figure 26. Safety Input remains in Stop mode

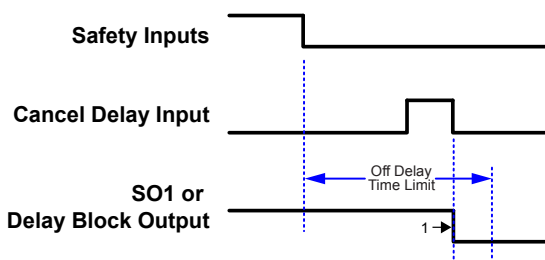

Note 1 - If "turn output off" function is selected

Figure 27. Turn Output OFF function

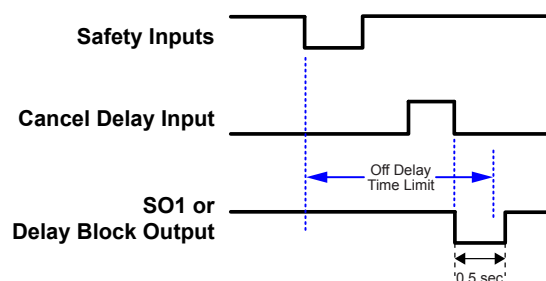

Figure 28. Keep Output ON function for Safety Inputs with the Latch Reset

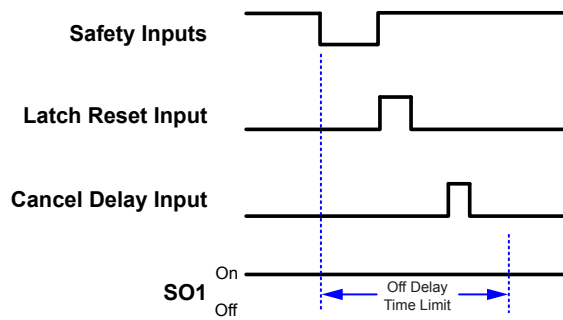
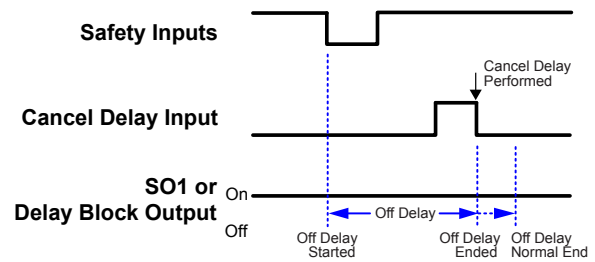

Figure 29. Keep Output ON function for Safety Inputs without the Latch Reset



7.6.1 Manual Reset Input

The Manual Reset input may be configured to perform any combination of the following (see [Adding Inputs and Status Outputs](#) on page 83):

Reset of Safety Inputs

Sets the output of the Latch Reset Block(s) to a Run state from a Latched state when the IN node is in a Run state

Reset of Safety Outputs

Sets the Output to ON if the Output Block configured for Latch Reset is ON.

Exceptions:

A Safety Output cannot be configured to use a Manual Reset when associated with a Two-Hand Control input or an Enabling Device function block.

System Reset

Sets the System to a Run state from a Lockout state due to a system fault if the cause of the fault has been removed. Possible scenarios when System Reset is needed include:

- Signals are detected on unused terminal pins
- Configuration Mode timeout
- Exiting Configuration Mode
- Internal faults
- Press Control faults



Note: A manual reset selected as a system reset can be used to finish the confirmation of a new configuration so that the power does not have to be cycled to the device.

Output Fault Reset

Clears the fault and allows the output to turn back ON if the cause of the fault has been removed. Possible scenarios when an Output Fault Reset is needed include:

- Output faults
- EDM or AVM faults

Manual Reset on Power-Up

Allows various Latch Reset Blocks and/or Output Blocks to be controlled by a single reset input after the power up.

Enable Mode Exit

A reset is required to exit the Enable Mode.

Track Input Group Reset

Resets the Status Output function **Track Input Group** and the Virtual Status Output function **Track Input Group**.

The reset switch must be mounted at a location that complies with the following warning. A key-actuated reset switch provides some operator or supervisory control, as the key can be removed from the switch and taken into the guarded area. However, this does not prevent from any unauthorized or inadvertent resets due to spare keys being in the possession of others, or additional personnel entering the guarded area unnoticed (a pass-through hazard).

**WARNING:**

- **Install reset switches properly**
- Failure to properly install reset switches could result in serious injury or death.
- Install reset switches so that they are accessible only from outside, and in full view of, the safeguarded space. Reset switches cannot be accessible from within the safeguarded space. Protect reset switches against unauthorized or inadvertent operation (for example, through the use of rings or guards). If there are any hazardous areas that are not visible from the reset switches, provide additional safeguarding.



Important: Resetting a safeguard must not initiate hazardous motion. Safe work procedures require a start-up procedure to be followed and the individual performing the reset to verify that the entire hazardous area is clear of all personnel **before each reset of the safeguard is performed**. If any area cannot be observed from the reset switch location, additional supplemental safeguarding must be used: at a minimum, visual and audible warnings of the machine start-up.



Note: Automatic Reset sets an output to return to an ON state without action by an individual once the input device(s) changes to the Run state and all other logic blocks are in their Run state. Also known as "Trip mode," automatic reset is typically used in applications in which the individual is continually being sensed by the safety input device.

**WARNING:**

- **Automatic Power Up**
- On power-up, the Safety Outputs and Latch Reset Blocks configured for automatic power-up will turn their outputs ON if all associated inputs are in the Run state.
- If manual reset is required, configure the outputs for a manual power mode.

Automatic and Manual Reset Inputs Mapped to the Same Safety Output

By default, Safety Outputs are configured for automatic reset (trip mode). They can be configured as a Latch Reset using the Solid-State Output Properties attribute of the Safety Output (see [Function Blocks](#) on page 110).

Safety Input Devices operate as automatic reset unless a Latch Reset Block is added. If a Latch Reset Block is added in line with an output configured for Latch Reset mode, the same or different Manual Reset Input Device(s) may be used to reset the Latch Reset Block and the Safety Output latch. If the same Manual Reset Input Device is used for both, and all inputs are in their Run state, a single reset action will unlatch the function block and the output block. If different Manual Reset Input Devices are used, the reset associated with the Safety Output must be the last one activated. This can be used to force a sequenced reset routine, which can be used to reduce or eliminate pass-through hazards in perimeter guarding applications (see [Safety Input Device Properties](#) on page 34).

If the controlling inputs to a Latch Reset Block or a Safety Output Block are not in the Run state, the reset for that block will be ignored.

Reset Signal Requirements

Reset input devices can be configured for monitored or non-monitored operation, as follows:

Monitored Reset

Requires the reset signal to transition from low (0 V DC) to high (24 V DC) and then back to low. The high state duration must be 0.5 seconds to 2 seconds. This is called a trailing edge event.

Non-Monitored Reset

Requires only that the reset signal transitions from low (0 V DC) to high (24 V DC) and stays high for at least 0.5 seconds. After the reset, the reset signal can be either high or low. This is called a leading-edge event.

7.7 Virtual Non-Safety Input Devices

This feature available on XS/SC26 FID 2 and later and SC10-2. The virtual non-safety input devices include manual reset, ON/OFF, mute enable, and cancel OFF-Delay.



WARNING: Virtual Non-Safety Inputs must never be used to control any safety-critical applications. If a Virtual Non-Safety Input is used to control a safety-critical application, a failure to danger is possible and may lead to serious injury or death.



Important: Resetting a safeguard must not initiate hazardous motion. Safe work procedures require a start-up procedure to be followed and the individual performing the reset to verify that the entire hazardous area is clear of all personnel before each reset of the safeguard is performed. If any area cannot be observed from the reset switch location, additional supplemental safeguarding must be used: at a minimum, visual and audible warnings of the machine start-up.

7.7.1 Virtual Manual Reset and Cancel Delay (RCD) Sequence

According to section 5.2.2 of EN ISO 13849-1:2015, a deliberate action by the operator is required to reset a safety function. Traditionally, this requirement is met by using a mechanical switch and associated wires connected to specified terminals on the Safety Controller. For a monitored reset, the contacts must be open initially, then closed, and then open again within the proper timing. If the timing is not too short or too long, it is determined to be deliberate and the reset is performed.

Banner Engineering has created a virtual reset solution that requires deliberate action. For example, in place of the mechanical switch, an HMI may be used. In place of the wires, a unique Actuation Code is used for each Safety Controller on a network. Also, each virtual reset within a Safety Controller is associated with a specific bit in a register. This bit, along with the Actuation Code, must be written and cleared in a coordinated way. If the steps are completed with the proper sequence and timing, it is determined to be deliberate and the reset is performed.

While the standards do not require a deliberate action to perform a virtual cancel delay, to avoid additional complexity, Banner Engineering has implemented this function in the same way as the virtual manual reset.

The user must set matching Actuation Codes in both the Safety Controller and the controlling network device (PLC, HMI, etc.). The Actuation Code is part of the Network Settings and is not included in the configuration Cyclic Redundancy Check (CRC). There is no default Actuation Code. The user must set one up on the **Network Settings** screen. Or, on Controllers with an onboard interface, when the **Use onboard interface to set the last octet and actuation code** checkbox selected, the actuation code can be set using the onboard interface. See [ClickSet IP Process](#) on page 167. The Actuation Code can be active for up to 2 seconds for it to be effective. Different Safety Controllers on the same network should have different Actuation Codes.



Note: When a virtual manual reset or cancel delay is added in on the **Functional View** tab, the checklist adds a note that an actuation code must be entered under **Network Settings**.

Figure 30. Example Checklist Warning

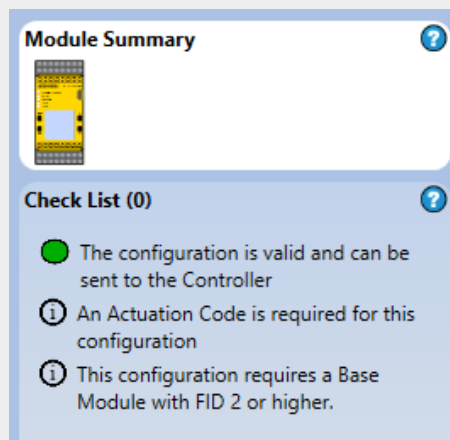

The HMI/PLC programmer can choose from two different methods, depending on their preferences; a feedback-based sequence or a timed sequence. These methods are described in the following figures. The actual register location depends upon which protocol is being used.

Virtual Reset or Cancel Delay (RCD) Sequence—Feedback Method

Figure 31. Virtual Reset or Cancel Delay (RCD) Sequence—Feedback Method

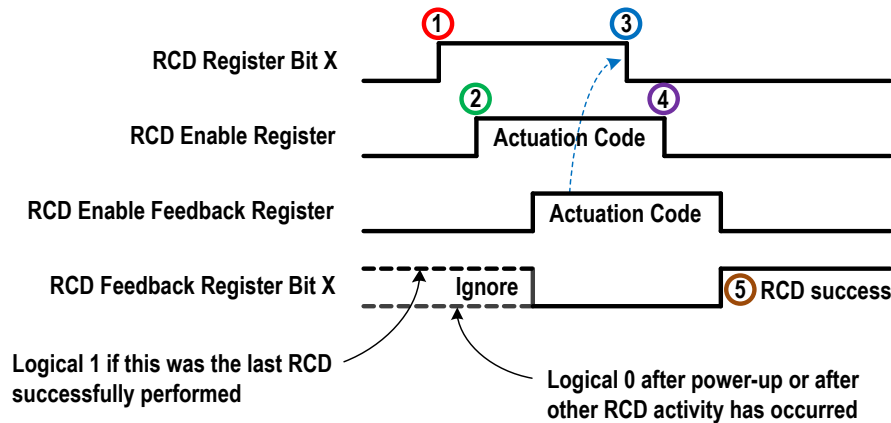

1. Write a logical 1 to the RCD Register Bit(s) corresponding to the desired Virtual Reset or Cancel Delay.
2. At the same time, or any time later, write the Actuation Code to the RCD Enable Register.
3. Monitor the RCD Enable Feedback Register for the Actuation Code to appear (125 ms typical). Then write a logical 0 to the RCD Register Bit.
4. At the same time, or any time later, clear the Actuation Code (write a logical 0 to the RCD Enable Register). This step must be completed within 2 seconds of when the code was first written (step 2).
5. If desired, monitor the RCD Feedback Register to know if the desired Reset or Cancel Delay was accepted (175 ms typical).

Note: The various needed register Bits can be found on the **Industrial Ethernet** tab of the Software by changing the Virtual Status Output selection to Virtual Non-Safety Inputs. The Actuation Code is created by the user under the Network Settings icon on the Tool bar.

Note: An AOI and PLC function block are available at www.bannerengineering.com on the Safety Controller product page. The AOI folder includes a Banner SC10 SC26 XS26 Reset and Cancel Delay Activation AOI readable file that can also help explain the process.

Virtual Reset or Cancel Delay (RCD) Sequence—Timed Method

Figure 32. Virtual Reset or Cancel Delay (RCD) Sequence—Timed Method

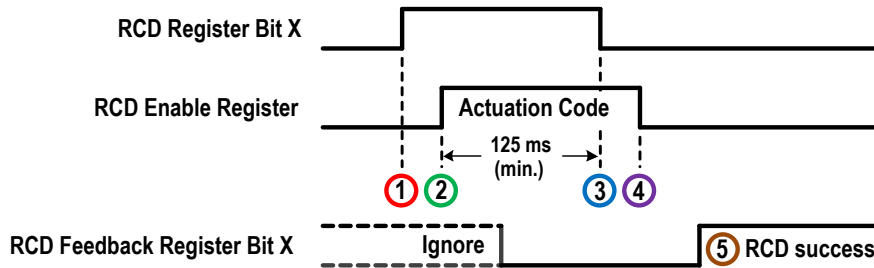

1. Write a logical 1 to the RCD Register Bit(s) corresponding to the desired Virtual Reset or Cancel Delay.
2. At the same time, or any time later, write the Actuation Code to the RCD Enable Register.
3. At least 125 ms after step 2, write a logical 0 to the RCD Register Bit.
4. At the same time, or any time later, clear the Actuation Code (write a logical 0 to the RCD Enable Register). This step must be completed within 2 seconds from when the code was first written (step 2).
5. If desired, monitor the RCD Feedback Register to know if the desired Reset or Cancel Delay was accepted (175 ms typical).

Virtual Manual Reset Devices are used to create a reset signal for an output or function block configured for a manual reset, requiring an operator action for the output of that block to turn on. Resets can also be created using physical reset input; see [Non-Safety Input Devices](#) on page 58.



WARNING: Virtual Manual Reset—Any Virtual Manual Reset configured to perform a Manual Power Up function in conjunction with equipment in several locations on the same network should be avoided unless all hazardous areas can be verified safe.

Virtual Cancel OFF-Delay Devices: provide the option to cancel a configured OFF-delay or One Shot time. It functions in one of the following ways:

- Keeps the safety output or delay block output ON
- Turns the safety output, delay block output, or one shot block output OFF immediately after the Safety Controller receives a Cancel OFF-Delay signal
- When **Cancel Type** is set to "Control Input", the safety output or delay block output stays on if the input turns ON again before the end of the delay

A status output function (Output Delay in Progress) indicates when a Cancel Delay Input can be activated to keep the OFF-delayed safety output ON. A cancel OFF-delay device can also be created using a physical input; see [Non-Safety Input Devices](#) on page 58.

Virtual Cancel OFF-Delay Timing

Figure 33. Safety Input remains in Stop mode

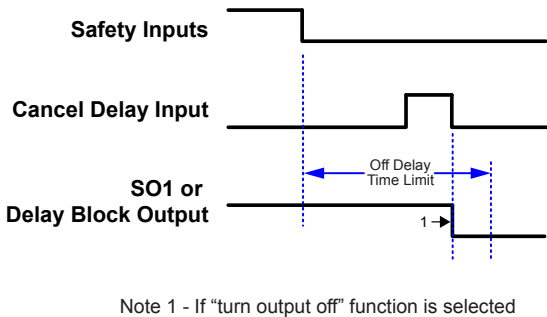

Note 1 - If "turn output off" function is selected

Figure 34. Turn Output OFF function

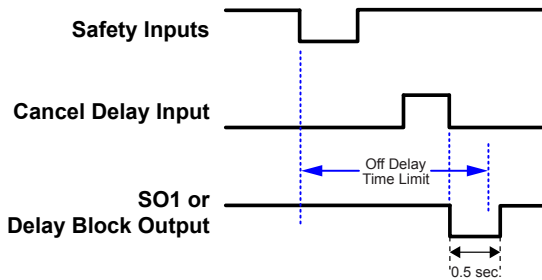

Figure 35. Keep Output ON function for Safety Inputs with the Latch Reset

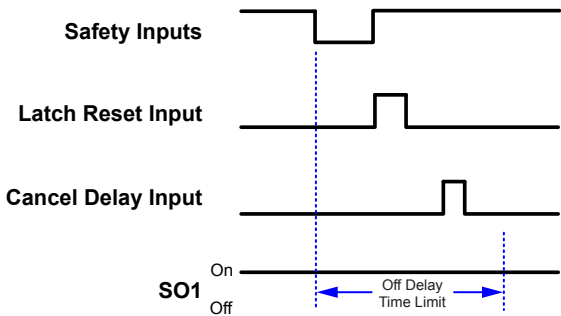
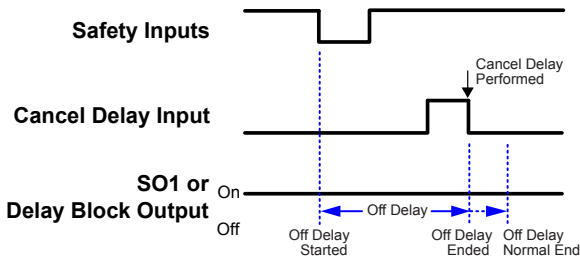

Figure 36. Keep Output ON function for Safety Inputs without the Latch Reset



7.7.2 Virtual ON/OFF and Mute Enable

Virtual ON/OFF

Provides an ON or OFF command to the machine. When all of the controlling safety inputs are in the Run state, this function permits the safety output to turn ON and OFF. The Run state is a logical 1 and the Stop state is a logical 0. A virtual ON/OFF input can be added without mapping to a safety output, allowing it to control a non-safety status output. An ON/OFF switch can also be created using a physical input; see [Non-Safety Input Devices](#) on page 58. XS/SC26 FID 4 or later: The virtual ON/OFF inputs are used to select the mode of the Press Control Mode Function Block. Three separate inputs are required to satisfy this block. The block does accept ON/OFF inputs.

Virtual Mute Enable

Signals the Safety Controller when the mute sensors are permitted to perform a mute function. When the mute enable function is configured, the mute sensors are not enabled to perform a mute function until the mute enable signal is in the Run state. The enable (Run) state is a logical 1 and the disable (Stop) state is a logical 0. A mute enable switch can also be created using a physical input; see [Non-Safety Input Devices](#) on page 58.

7.8 Safety Outputs

XS/SC26

The Base Controller has two pairs of solid-state safety outputs (terminals SO1a and b, and SO2a and b). These outputs provide up to 500 mA each at 24 V DC. Each redundant Solid-State Safety Output can be configured to function individually or in pairs, for example, split SO1a independent of SO1b, or SO1 as a dual-channel output.

Additional safety outputs can be added to expandable models of the Base Controller by incorporating I/O modules. These additional safety outputs can be isolated relay outputs that can be used to control/switch a wide range of power characteristics (see [XS/SC26 Specifications](#) on page 20).

SC10-2

The SC10-2 has two isolated redundant relay outputs. Each relay output has three independent sets of contacts. See [SC10-2 Specifications](#) on page 24 for rating and derating considerations.

XS/SC26 and SC10-2



WARNING:

- **Connect the safety outputs properly**
- Failure to follow these instructions could result in serious injury or death.
- Safety outputs must be connected to the machine control so that the machine's safety-related control system interrupts the circuit to the machine primary control element(s), resulting in a non-hazardous condition.
- Do not wire an intermediate device(s), such as a PLC, PES, or PC, that can fail in such a manner that there is the loss of the safety stop command, or that the safety function can be suspended, overridden, or defeated, unless accomplished with the same or greater degree of safety.

The following list describes additional nodes and attributes that can be configured from the Safety Output function block **Properties** window (see [Adding Inputs and Status Outputs](#) on page 83):

EDM (External Device Monitoring)

Enables the Safety Controller to monitor devices under control (FSDs and MPCEs) for proper response to the stopping command of the safety outputs. **It is strongly recommended to incorporate EDM (or AVM)** in the machine design and the Safety Controller configuration to ensure the proper level of safety circuit integrity (see [EDM and FSD Wiring](#) on page 70).

AVM (Adjustable Valve Monitoring)

Enables the Safety Controller to monitor valves or other devices that may become slow, stick, or fail in an energized state or position and whose operation needs to be verified after a Stop signal occurs. Up to three AVM inputs can be selected if EDM is not used. **It is strongly recommended to incorporate AVM (or EDM)** in the machine design and the Safety Controller configuration to ensure the proper level of safety circuit integrity (see [Adjustable Valve Monitoring \(AVM\) Function](#) on page 48).

LR (Latch Reset)

Keeps the SO or RO output OFF until the input changes to the Run state and a manual reset operation is performed. See [Manual Reset Input](#) on page 59 for more information.

RE (Reset Enable)

This option appears only if **LR (Latch Reset)** is enabled. The **Latch Reset** can be controlled by selecting **Reset Enable** to restrict when the safety output can be reset to a Run condition.

FR (Fault Reset)

Provides a manual reset function when input faults occur. The FR node needs to be connected to a Manual Reset button or signal. This function is used to keep the SO or RO output OFF until the Input device fault is cleared, the faulted device is in the Run state, and a manual reset operation is performed. This replaces power down/up cycle reset operation. See [Manual Reset Input](#) on page 59 for more information.

Power-up mode

The safety output can be configured for three power-up scenarios (operational characteristics when power is applied):

- Normal Power-Up Mode (default)
- Manual Power-up Mode: Requires a Manual Reset Input configured for Manual Power Up; this selection requires a reset at power up to turn the outputs on, even if configured for automatic reset
- Automatic Power-Up Mode: Allows the outputs to turn on at power up if the logic is in the ON state, even if a latch reset function (block or output node) is configured

See [Manual Reset Input](#) on page 59 for more information.

Split (Safety Outputs)—XS/SC26 only

This option is only available for solid-state safety outputs. Each redundant solid-state safety output can be configured to function individually or in pairs (default). Splitting a solid-state safety output creates two independent single-channel outputs (control of SO1a is independent of SO1b). To combine a split safety output, open the Mx:SOxA **Properties** window and click **Join**.

ON-Delays and OFF-Delays

Each safety output can be configured to function with either an ON-delay or an OFF-delay (see [Figure 37](#) on page 65), where the output turns ON or OFF only after the time limit has elapsed. An output cannot have both ON- and OFF-delays. The ON- and OFF-delay time limit options range from 100 milliseconds to 5 minutes, in 1 millisecond increments.

Figure 37. Timing Diagram—General Safety Output ON-Delay and OFF-Delay

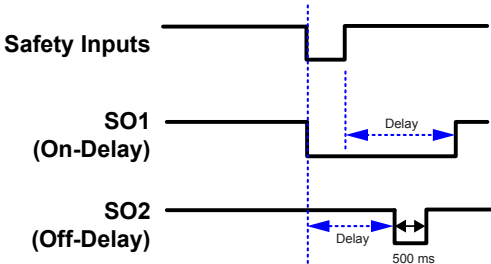

WARNING:

- With a power interruption or loss, an OFF-delay time can end immediately.
- Failure to follow these instructions could result in serious injury or death.
- The safety output OFF-delay time is honored even if the safety input that caused the OFF-delay timer to start switches back to the Run state before the delay time expires. If such an immediate machine stop condition could cause a potential danger, taken additional safeguarding measures to prevent injuries.

Linking Outputs

Two safety outputs can be linked together when one of the safety outputs is configured for an OFF-delay, and the other does not have a delay. After it is linked, the non-delayed output does not immediately turn back on if the controlling input turns on during the OFF-delay as shown in [Figure 40](#) on page 66. To link two safety outputs:

1. Open the **Properties** window of the safety output that needs to have an OFF-delay.
2. Select **OFF-Delay** from the *Safety Output Delay* drop-down list.

Figure 38. Example Safety Output Delay Selection: OFF-Delay

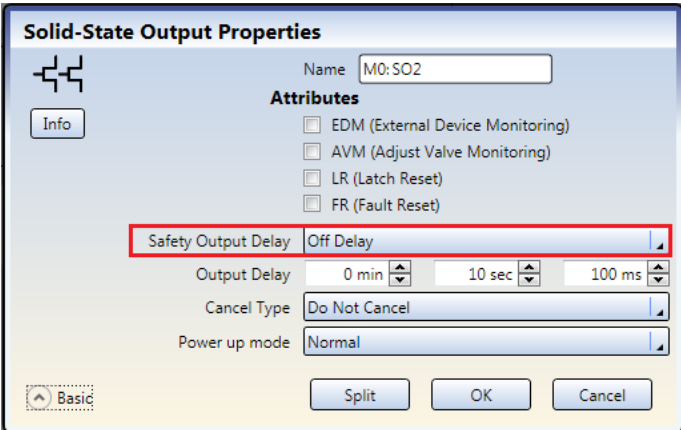

3. Set the desired Output Delay time.
4. Click **OK**.
5. Open the **Properties** window of the safety output that will link to the safety output with an OFF-Delay.
6. From *Link to Safety Output* drop-down list, select the safety output with an OFF-Delay to which you wish to link this safety output.

Figure 39. Example Link to Safety Output Selection

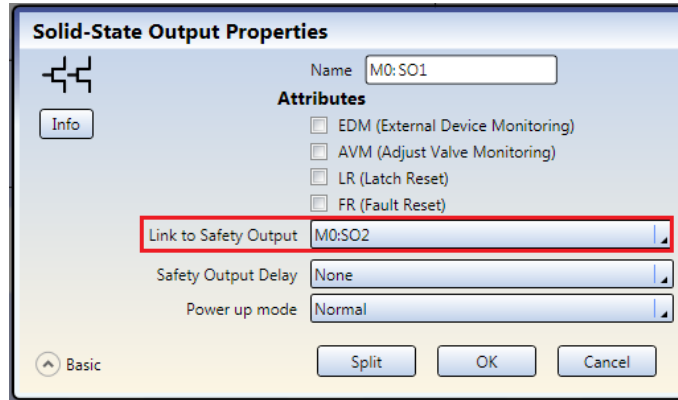

Note: The same input(s) need to be connected to both safety outputs for outputs to show up as available for linking.

7. Click **OK**. The linked safety output will have a link icon indicator.

Figure 40. Timing Diagram—Linked Safety Outputs

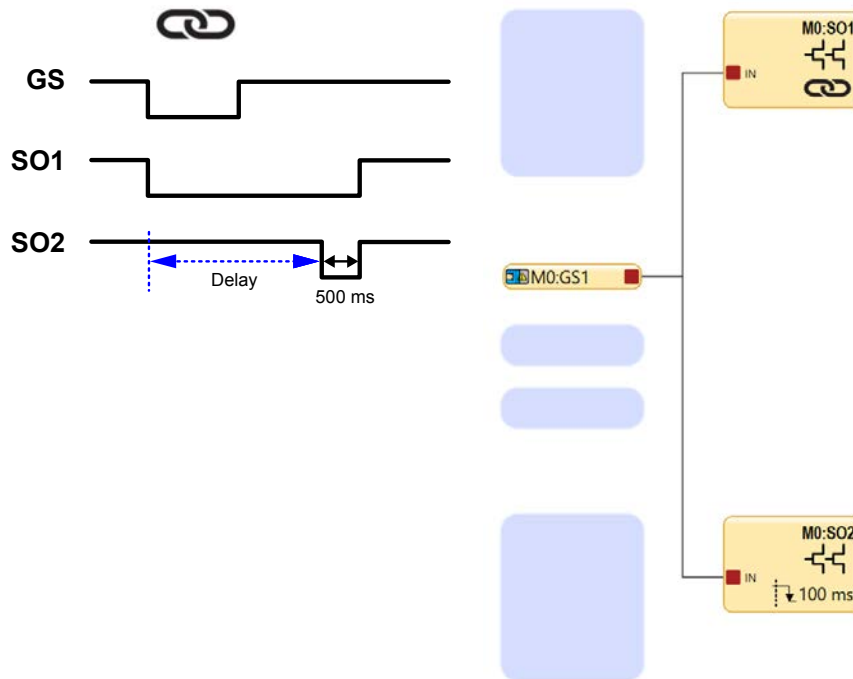

7.8.1 Solid-State Safety Outputs

This feature is available on XS/SC26.

The solid-state Safety Outputs, for example, SO1a and b, and SO2a and b, are actively monitored to detect short circuits to the supply voltage, to each other, and to other voltage sources and are designed for Category 4 safety applications. If a failure is detected on one channel of a safety output pair, both outputs attempt to turn Off and will enter a lockout state. The output without the fault is able to turn off the hazardous motion.

Similarly, a Safety Output that is used individually (split), is also actively monitored to detect short circuits to other power sources, but is unable to perform any actions. Take extreme care in the wiring of the terminals and in the routing of the wires to avoid the possibility of shorts to other voltage sources, including other Safety Outputs. Each split Safety Output is sufficient for Category 3 applications due to an internal series connection of two switching devices, but an external short must be prevented.



Important: When Solid-State Safety Output modules (XS2so or XS4so) are used, the power to those modules must be applied either prior to or within 5 seconds after applying the power to the Base Controller, if using separate power supplies.



Note: Each Solid-State Safety Output module (XS2so or XS4so) has two 24 V terminals and two 0 V terminals. Only one of each is needed to power the individual module. The second set can be used to jumper power to the next module.



WARNING:

- **Single-Channel (Split) Outputs use in Safety Critical Applications**
- Failure to incorporate proper fault exclusion methods when using single-channel outputs in safety critical applications may cause a loss of safety control and result in a serious injury or death.
- If a single-channel output is used in a safety critical application then fault exclusion principles must be incorporated to ensure Category 3 safety operation. Routing and managing single-channel output wires so shorts to other outputs or other voltage sources are not possible is an example of a proper fault exclusion method.

Whenever possible, incorporating External Device Monitoring (EDM) and/or Adjustable Valve Monitoring (AVM) is highly recommended to monitor devices under control (FSDs and MPCEs) for unsafe failures. See [External Device Monitoring \(EDM\)](#) on page 70 for more information.

Output Connections

The Safety Outputs must be connected to the machine control such that the machine's safety-related control system interrupts the circuit or power to the machine primary control element(s) (MPCE), resulting in a non-hazardous condition.

When used, Final Switching Devices (FSDs) typically accomplish this when the safety outputs go to the Off state. Refer to the [XS/SC26 Specifications](#) on page 20 before making connections and interfacing the Safety Controller to the machine.

The level of the safety circuit integrity must be determined by risk assessment; this level is dependent on the configuration, proper installation of external circuitry, and the type and installation of the devices under control (FSDs and MPCEs). The solid-state safety outputs are suitable for Category 4 PL e / SIL 3 applications when controlled in pairs (not split) and for applications up to Category 3 PL d / SIL 2 when acting independently (split) when appropriate fault exclusion has been employed. See [Figure 41](#) on page 68 for hookup examples.



WARNING:

- **Safety Output Lead Resistance**
- A resistance higher than 10 ohms could mask a short between the dual-channel safety outputs and could create an unsafe condition that could result in serious injury or death.
- Do not exceed 10 ohms resistance in the safety output wires.

Common Wire Installation

Consider the wire resistance of the 0 V common wire and the currents flowing in that wire to avoid nuisance lockouts. Notice the location of the resistance symbol in the diagram below, representing 0 V common wire resistance (R_L).

Methods to prevent this situation include:

- Using larger gauge or shorter wires to reduce the resistance (R_L) of the 0 V common wire
- Separate the 0 V common wire from the loads connected to the Safety Controller and the 0 V common wire from other equipment powered by the common 24 V supply

Figure 41. Common Wire Installation

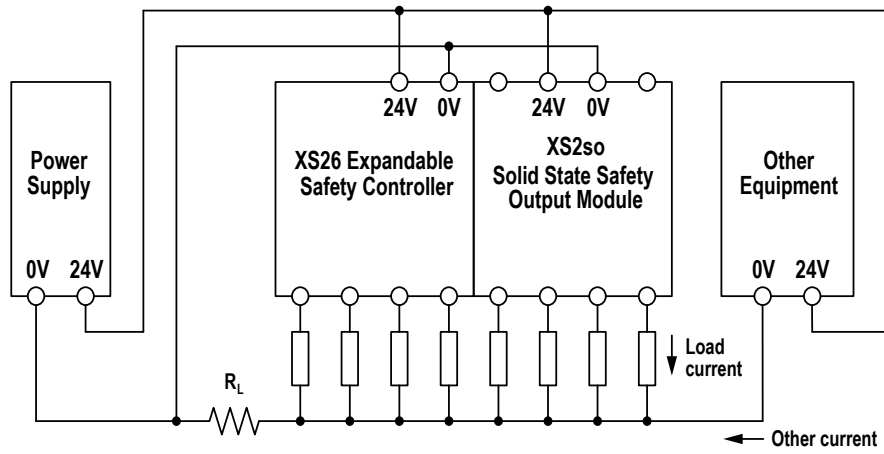

R_L = Common leadwire shared by multiple loads or systems

Sharing of small gauge leadwire can lead to faults on solid state outputs.



Note: When the Safety Output turns Off, the voltage at that output terminal must drop below 1.7 V with respect to the 0 V terminal on that module. If the voltage is higher than 1.7 V, the Safety Controller will decide that the output is still on, resulting in a lockout. Consider using larger gauge wires, shorter wires, or using a single point grounding scheme similar to what is shown in the following diagrams.

Figure 42. Wiring Diagram—Recommended Grounding

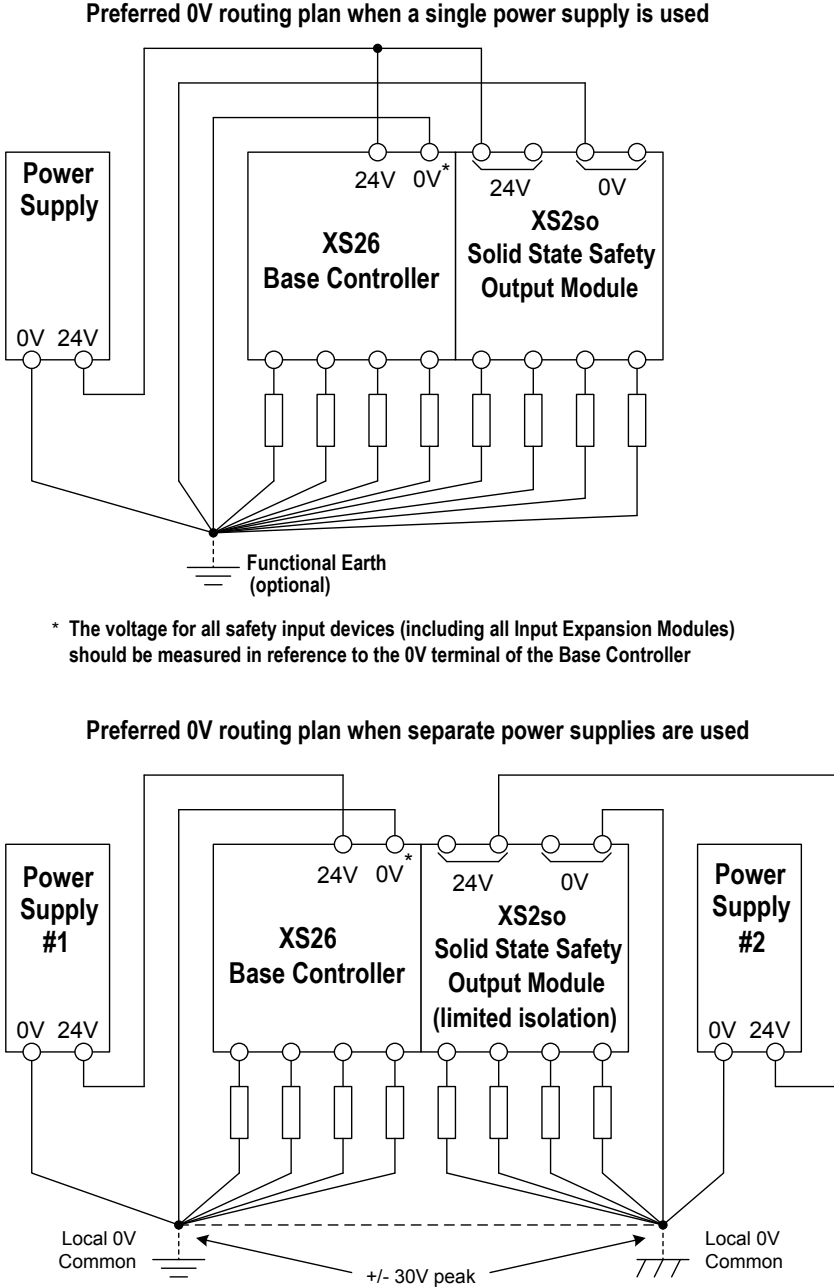

Note: The second set (the unused 24 V and 0 V terminals above) can be used to jumper power from one module to the next module.

7.8.2 Safety Relay Outputs

XS/SC26 Expansion Safety Relay modules and the SC10-2 have isolated redundant relay outputs that can be used to control/switch a wide range of power characteristics (see [XS/SC26 Specifications](#) on page 20 and [SC10-2 Specifications](#) on page 24). Unlike a solid-state Safety Output, within an output module an individual safety relay output (Mx:ROx) functions as a group and cannot be split.



Note: Each RO of an XS1ro or XS2ro module has two normally open output switching channels for connection to control-reliable power interrupt circuits and one normally closed auxiliary output channel. Each RO of the SC10-2 has three normally open output switching channels for connection to control-reliable power interrupt circuits.

The Safety Relay Outputs are controlled and monitored by the XS/SC26 Base Controller or the SC10-2 without requiring additional wiring.

For circuits requiring the highest levels of safety and reliability, when used in pairs (two normally open), either Safety Output must be capable of stopping the motion of the guarded machine in an emergency. When used individually (a single normally open output), fault exclusion must ensure that failures cannot occur that would result in the loss of the safety function, for example, a short-circuit to another safety output or a secondary source of energy or voltage. For more information, see *Single-channel Control* in [Safety \(Protective\) Stop Circuits](#) on page 73 and [Fault Exclusion](#) on page 33.

Whenever possible, incorporating External Device Monitoring (EDM) and/or Adjustable Valve Monitoring (AVM) is highly recommended to monitor devices under control (FSDs and MPCEs) for unsafe failures. See [External Device Monitoring \(EDM\)](#) on page 70 for more information.

Output Connections—The Safety Relay Outputs must be connected to the machine control such that the machine's safety-related control system interrupts the circuit or power to the machine primary control element(s) (MPCE), resulting in a non-hazardous condition. When used, Final Switching Devices (FSDs) typically accomplish this when the safety outputs go to the OFF state.

The Safety Relay Outputs can be used as the Final Switching Device (FSD) and can be interfaced in either a dual-channel or single-channel safety (protective) stop circuit (see [FSD Interfacing Connections](#) on page 72). Refer to [XS/SC26 Specifications](#) on page 20 and [SC10-2 Specifications](#) on page 24 before making connections and interfacing the Safety Controller to the machine.

The level of the safety circuit integrity must be determined by risk assessment; this level is dependent on the configuration, proper installation of external circuitry, and the type and installation of the devices under control (FSDs and MPCEs). The safety relay outputs are suitable for Category 4 PL e / SIL 3. See [Figure 41](#) on page 68 for wiring examples.



Important: The user is responsible for supplying overcurrent protection for all relay outputs.

Overvoltage Category II and III Installations (EN 50178 and IEC 60664-1)

The XS/SC26 and SC10-2 are rated for Overvoltage Category III when voltages of 1 V to 150 V AC/DC are applied to the output relay contacts. They are rated for Overvoltage Category II when voltages of 151 V to 250 V AC/DC are applied to the output relay contacts and no additional precautions are taken to attenuate possible overvoltage situations in the supply voltage. The XS/SC26 or SC10-2 can be used in an Overvoltage Category III environment (with voltages of 151 V to 250 V AC/DC) if care is taken either to reduce the level of electrical disturbances seen by the XS/SC26 or SC10-2 to Overvoltage Category II levels by installing surge suppressor devices (for example, arc suppressors), or to install extra external insulation in order to isolate both the XS/SC26 or SC10-2 and the user from the higher voltage levels of a Category III environment.

For Overvoltage Category III installations with applied voltages from 151 V to 250 V AC/DC applied to the output contact(s): the XS/SC26 or SC10-2 may be used under the conditions of a higher overvoltage category where appropriate overvoltage reduction is provided. Appropriate methods include:

- An overvoltage protective device
- A transformer with isolated windings
- A distribution system with multiple branch circuits (capable of diverting energy of surges)
- A capacitance capable of absorbing energy of surges
- A resistance or similar damping device capable of dissipating the energy of surges

When switching inductive AC loads, it is good practice to protect the XS/SC26 or SC10-2 outputs by installing appropriately-sized arc suppressors. However, if arc suppressors are used, they must be installed across the load being switched (for example, across the coils of external safety relays), and never across the XS/SC26 or SC10-2 output contacts (see the warning on arc suppressors in [Generic XS/SC26 Hookup: Safety Output with EDM](#) on page 75 and [Generic SC10-2 Hookup: Safety Output with EDM](#) on page 78).

7.8.3 EDM and FSD Wiring

External Device Monitoring (EDM)

The Safety Controller's safety outputs can control external relays, contactors, or other devices that have a set of normally closed (NC), force-guided (mechanically linked) contacts that can be used for monitoring the state of the machine power contacts. The monitoring contacts are normally closed (NC) when the device is turned OFF. This capability allows the Safety Controller to detect if the devices under load are responding to the safety output, or if the normally open (NO) contacts are possibly welded closed or stuck ON.



Note: The relays internal to the XS1ro, XS2ro and the SC10-2 are always monitored by the modules. EDM is only needed for devices that are external to the controllers.

The EDM function provides a method to monitor these types of faults and to ensure the functional integrity of a dual-channel system, including the MPCEs and the FSDs.

A single EDM input can be mapped to one or multiple Safety Outputs. This is accomplished by opening the Safety Output **Properties** window and checking **EDM**, then adding **External Device Monitoring** from the **Safety Input** tab in the **Add Equipment** window (accessed from the **Equipment** tab or **Functional View** tab), and connecting the **External Device Monitoring** input to the **EDM** node of the Safety Output.

The EDM inputs can be configured as one-channel or two-channel monitoring. One-channel EDM inputs are used when the output signal switching device (OSSD) outputs directly control the de-energizing of the MPCEs or external devices.

One-Channel Monitoring

A series connection of closed monitor contacts that are forced-guided (mechanically linked) from each device controlled by the Safety Controller. The monitor contacts must be closed before the Safety Controller outputs can be reset (either manual or automatic). After a reset is executed and the safety outputs turn ON, the status of the monitor contacts are no longer monitored and may change state. However, the monitor contacts must be closed within 250 milliseconds of the safety outputs changing from ON to OFF. See [Figure 45](#) on page 72.

Two-Channel Monitoring

An independent connection of closed monitor contacts that are forced-guided (mechanically linked) from each device controlled by the Safety Controller. Both EDM inputs must be closed before the Safety Controller can be reset and the OSSDs can turn ON. While the OSSDs are ON, the inputs may change state (either both open, or both closed). A lockout occurs if the inputs remain in opposite states for more than 250 milliseconds. See [Figure 47](#) on page 72.

No Monitoring (default)

If no monitoring is desired, do not enable the Safety Output EDM node. If the Safety Controller does not use the EDM function in Category 3 or Category 4 applications, the user must make sure that any single failure or accumulation of failures of the external devices does not result in a hazardous condition and that a successive machine cycle is prevented.



WARNING:

- **External Device Monitoring (EDM)**
- Creating a hazardous situation could result in serious injury or death.
- If the system is configured for “no monitoring,” it is the user’s responsibility to ensure this does not create a hazardous situation.



CAUTION:

- **Use Machine Primary Control Element (MPCE) monitoring contacts to maintain control reliability.**
- Failure to follow these instructions could result in serious injury or death.
- Wire at least one normally closed, forced-guided monitoring contact of each MPCE or external device to monitor the state of the MPCEs (as shown). If this is done, proper operation of the MPCEs will be verified.

Figure 43. One-channel EDM Wiring

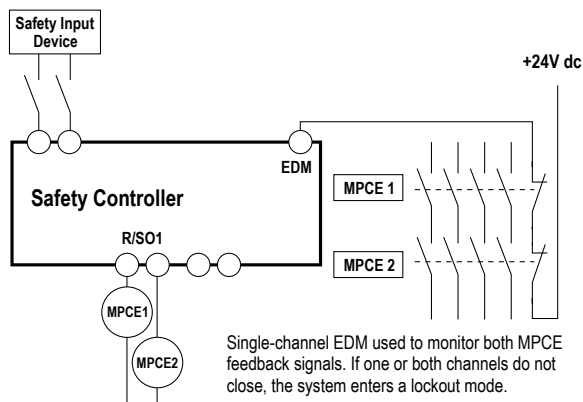

Figure 44. Two-channel EDM Wiring

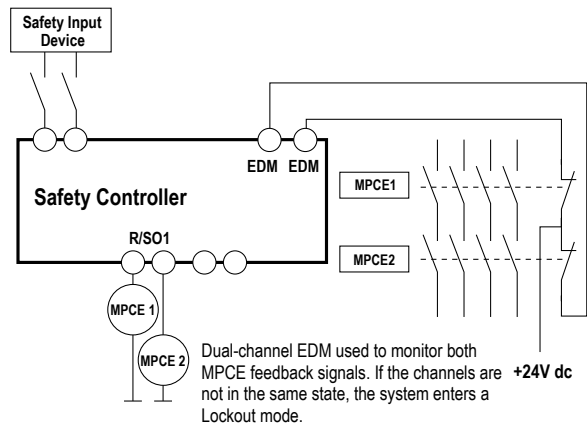
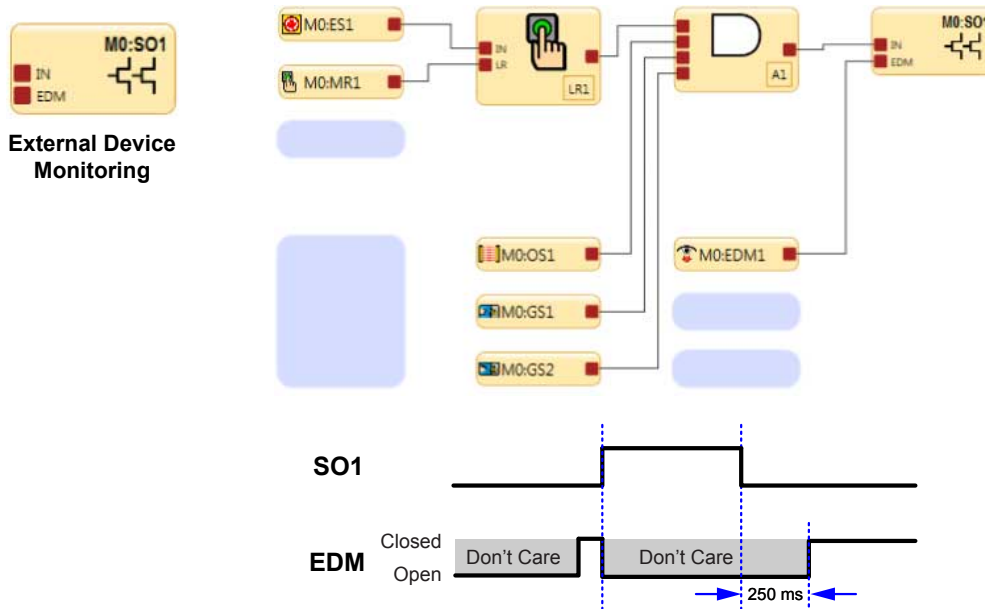

Figure 45. Timing logic: One-channel EDM status, with respect to Safety Output



External Device Monitoring EDM is a way to check the operation of dual-channel final switching devices or machine primary control elements. The force guided NC monitoring contacts of the FSD or MPCE are used as an input to detect a “stuck on” fault condition and will prevent the safety controller outputs from turning ON.

For two-channel EDM, as shown below, both channels must be closed before the Safety Output(s) turn ON.

Figure 46. Timing logic: Two-channel EDM, timing between channels

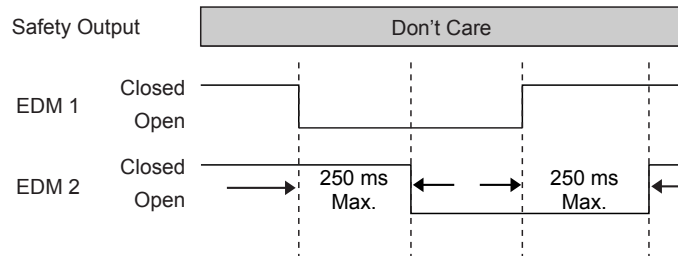
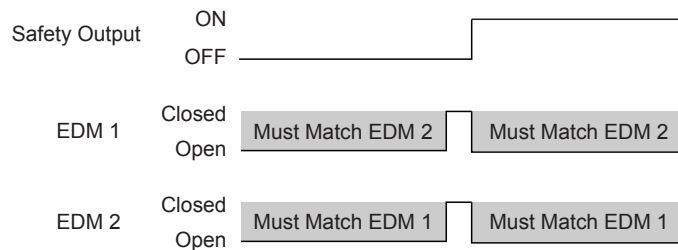

Figure 47. Timing logic: Two-channel EDM status, with respect to Safety Output



FSD Interfacing Connections

Final switching devices (FSDs) interrupt the power in the circuit to the Machine Primary Control Element (MPCE) when the Safety Outputs go to the Off-state. FSDs can take many forms, though the most common are forced-guided (mechanically linked) relays or Interfacing Modules. The mechanical linkage between the contacts allows the device to be monitored by the external device monitoring circuit for certain failures.

Depending on the application, the use of FSDs can facilitate controlling voltage and current that differs from the Safety Outputs of the Safety Controller. FSDs may also be used to control an additional number of hazards by creating multiple safety stop circuits.

Safety (Protective) Stop Circuits

A safety stop allows for an orderly cessation of motion or hazardous situation for safeguarding purposes, which results in a stop of motion and removal of power from the MPCEs (assuming this does not create additional hazards). A safety stop circuit typically comprises a minimum of two normally open (NO) contacts from forced-guided (mechanically linked) relays, which are monitored (via a mechanically linked normally closed (NC) contact) to detect certain failures so that the loss of the safety function does not occur. Such a circuit can be described as a “safe switching point.”

Typically, safety stop circuits are a series connection of at least two NO contacts coming from two separate, positive-guided relays, each controlled by one separate safety output of the Safety Controller. The safety function relies on the use of redundant contacts to control a single hazard, so that if one contact fails ON, the second contact stops the hazard and prevents the next cycle from occurring.

Interfacing safety stop circuits must be wired so that the safety function cannot be suspended, overridden, or defeated, unless accomplished in a manner at the same or greater degree of safety as the machine’s safety-related control system that includes the Safety Controller.

The NO outputs from an interfacing module are a series connection of redundant contacts that form safety stop circuits and can be used in either single-channel or dual-channel control methods.

Dual-Channel Control—Dual-channel (or two-channel) control has the ability to electrically extend the safe switching point beyond the FSD contacts. With proper monitoring, such as EDM, this method of interfacing is capable of detecting certain failures in the control wiring between the safety stop circuit and the MPCEs. These failures include a short-circuit of one channel to a secondary source of energy or voltage, or the loss of the switching action of one of the FSD outputs, which may lead to the loss of redundancy or a complete loss of safety if not detected and corrected.

The possibility of a wiring failure increases:

- As the physical distance between the FSD safety stop circuits and the MPCEs increase
- As the length or the routing of the interconnecting wires increases
- If the FSD safety stop circuits and the MPCEs are located in different enclosures

Thus, dual-channel control with EDM monitoring should be used in any installation where the FSDs are located remotely from the MPCEs.

Single-Channel Control—Single-channel (or one-channel) control uses a series connection of FSD contacts to form a safe switching point. After this point in the machine’s safety-related control system, failures that would result in the loss of the safety function can occur, for example, a short-circuit to a secondary source of energy or voltage.

Thus, this method of interfacing should be used only in installations where FSD safety stop circuits and the MPCEs are physically located within the same control panel, adjacent to each other, and are directly connected to each other; or where the possibility of such a failure can be excluded. If this cannot be achieved, then two-channel control should be used.

Methods to exclude the possibility of these failures include, but are not limited to:

- Physically separating interconnecting control wires from each other and from secondary sources of power
- Routing interconnecting control wires in separate conduit, runs, or channels
- Routing interconnecting control wires with low voltage or neutral that cannot result in energizing the hazard
- Locating all elements (modules, switches, devices under control, etc.) within the same control panel, adjacent to each other, and directly connected with short wires
- Properly installing multi-conductor cabling and multiple wires that pass through strain-relief fittings. Over-tightening of a strain-relief can cause short circuits at that point
- Using positive-opening or direct-drive components installed and mounted in a positive mode



WARNING:

- **Properly install arc or transient suppressors**
- Failure to follow these instructions could result in serious injury or death.
- Install any suppressors as shown across the coils of the FSDs or MPCEs. Do not install suppressors directly across the contacts of the FSDs or MPCEs. In such a configuration, it is possible for suppressors to fail as a short circuit.



WARNING:

- **Safety Output Interfacing** — To ensure proper operation, the Banner Engineering product output parameters and machine input parameters must be considered when interfacing the solid-state safety outputs to the machine inputs.
- **Failure to properly interface the safety outputs to the guarded machine may result in serious bodily injury or death.**
- Machine control circuitry must be designed so that:
 - The maximum cable resistance value between the Safety Controller solid-state safety outputs and the machine inputs is not exceeded.
 - The Safety Controller's solid-state safety output maximum OFF state voltage does not result in an ON condition.
 - The Safety Controller's solid-state safety output maximum leakage current, due to the loss of 0 V, does not result in an ON condition.



WARNING:

- **Risk of electric shock**
- Use extreme caution to avoid electrical shock. Serious injury or death could result.
- Always disconnect power from the safety system (for example, device, module, interfacing, etc.), guarded machine, and/or the machine being controlled before making any connections or replacing any component. Lockout/tagout procedures might be required. Refer to OSHA 29CFR1910.147, ANSI Z244-1, or the applicable standard for controlling hazardous energy.
- Make no more connections to the device or system than are described in this manual. Electrical installation and wiring must be made by a Qualified Person¹⁶ and must comply with the applicable electrical standards and wiring codes, such as the NEC (National Electrical Code), NFPA 79, or IEC 60204-1, and all applicable local standards and codes.



WARNING:

- **Properly Wire the Device**
- Failure to properly wire the Safety Controller to any particular machine could result in a dangerous condition that could result in serious injury or death.
- The user is responsible for properly wiring the Safety Controller. The generalized wiring configurations are provided only to illustrate the importance of proper installation.

¹⁶ A person who, by possession of a recognized degree or certificate of professional training, or who, by extensive knowledge, training and experience, has successfully demonstrated the ability to solve problems relating to the subject matter and work.

Generic XS/SC26 Hookup: Safety Output with EDM

Figure 48. Generic XS/SC26 Hookup: Solid-State Safety Output with EDM

Solid-State Safety Outputs SO2, SO3, and SO4 can be wired similarly.

When a Solid-State Safety Output has been split into two individual outputs, each output requires an individual EDM or AVM input for monitoring.

DC common (0Vdc) must be common between the module's 0Vdc terminal and the common of the load (e.g. FSD).

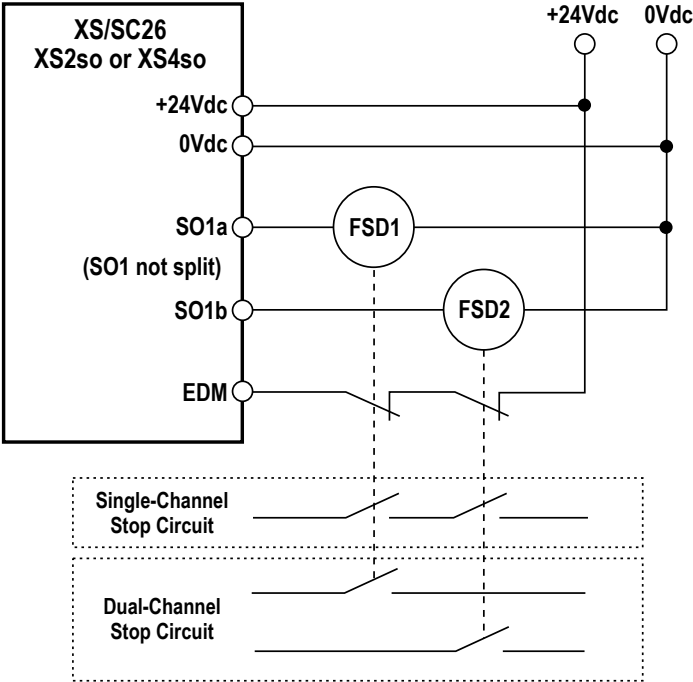
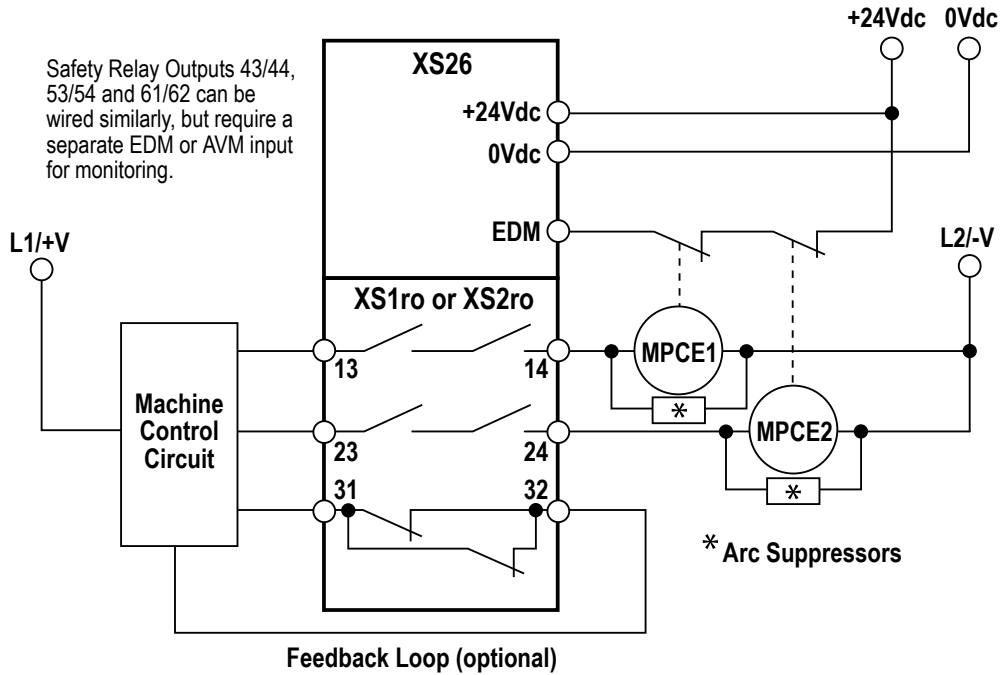

Figure 49. Generic XS/SC26 Hookup: Safety Relay Output (Dual-Channel) with EDM



WARNING:

- **Properly install arc or transient suppressors**
- Failure to follow these instructions could result in serious injury or death.
- Install any suppressors as shown across the coils of the machine primary control elements. Do not install suppressors directly across the output contacts of the safety or interface module. In such a configuration, it is possible for suppressors to fail as a short circuit.

Figure 50. Generic XS/SC26 Hookup: Solid-State Safety Output to IM-T-9A

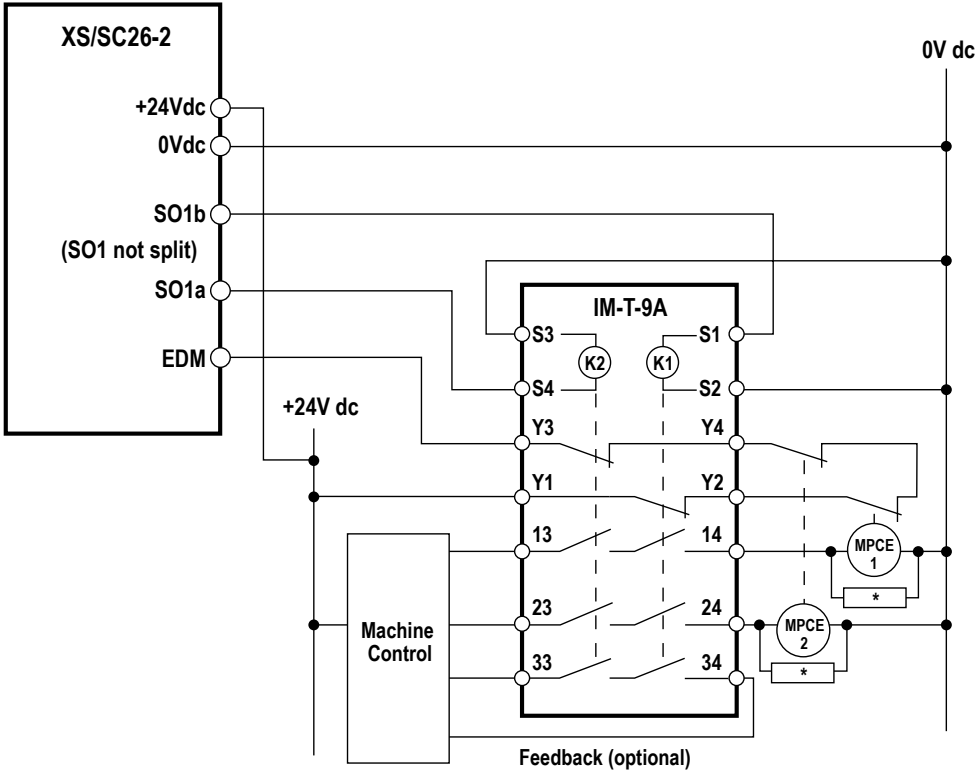

* Installation of transient (arc) suppressors across the coils of MPCE1 and MPCE2 is recommended (see Warning)



WARNING:

- **Properly install arc or transient suppressors**
- Failure to follow these instructions could result in serious injury or death.
- Install any suppressors as shown across the coils of the machine primary control elements. Do not install suppressors directly across the output contacts of the safety or interface module. In such a configuration, it is possible for suppressors to fail as a short circuit.

Generic SC10-2 Hookup: Safety Output with EDM

Figure 51. Generic SC10-2 Hookup: Safety Relay Output (Dual-Channel) with EDM

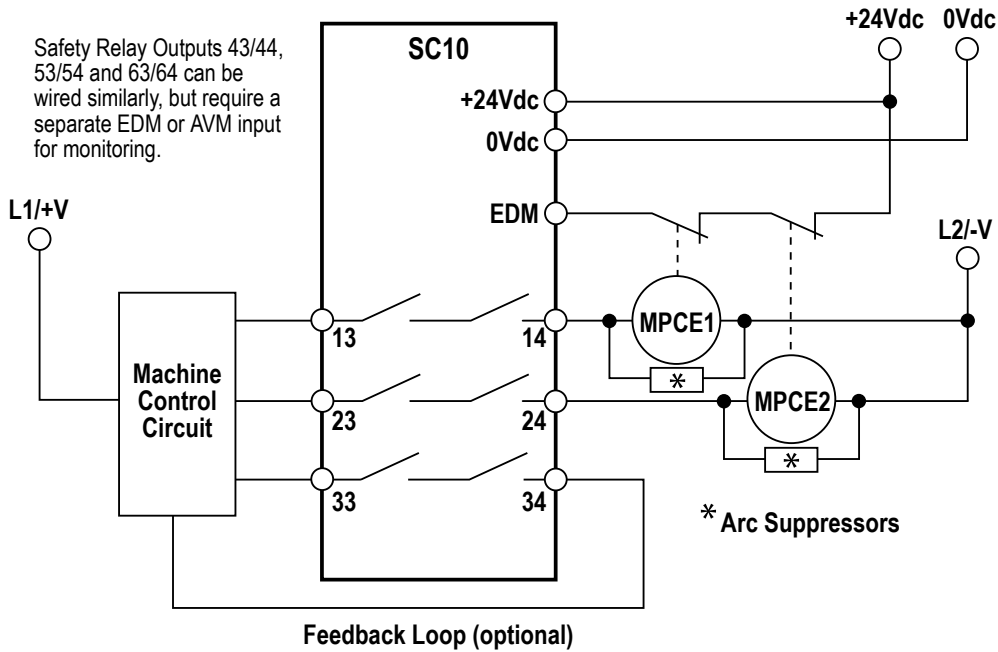

WARNING:

- **Properly install arc or transient suppressors**
- Failure to follow these instructions could result in serious injury or death.
- Install any suppressors as shown across the coils of the machine primary control elements. Do not install suppressors directly across the output contacts of the safety or interface module. In such a configuration, it is possible for suppressors to fail as a short circuit.

7.9 Status Outputs

For instructions on how to add a status output, see [Adding Status Outputs](#) on page 87.

A status output can be used to send a non-safety signal to devices such as lights or programmable logic controllers (PLCs) to signify the state of an input, safety output, or logic block or function block. For example, a Track Input status output is used to signify the state (ON or OFF) of the selected input (to the light or the PLC).

7.9.1 Status Output Signal Conventions



Note: You cannot use the safety outputs as status outputs in the SC10-2.

There are two signal conventions selectable for each status output: "PNP ON" (sourcing 24 V DC), or "PNP OFF" (non-conducting). The default convention is Active = PNP ON.

For XS/SC26 FID 4 and later, a flashing rate can also be configured for a status output in the ON state. The three options are:

- None (for ON solid)
- Normal (cycling 500 ms ON and 500 ms OFF)
- Fast (cycling 150 ms ON and 150 ms OFF)

The default flashing rate is none. Configuring a flash rate is not possible for a Mute status output (see Mute in [Status Output Functionality](#) on page 79).

Table 6: Status Output Signal Conventions

Function	Signal Conventions			
	Active = PNP ON		Active = PNP OFF	
	Status Output State		Status Output State	
	+24 V DC	OFF	OFF	24 V DC
Bypass	Bypassed	Not Bypassed	Bypassed	Not Bypassed
Mute	Muted	Not Muted	Muted	Not Muted
Output Delay In Progress	Delay	No Delay	Delay	No Delay
Track Input	Run	Stop	Run	Stop
Track Input Fault	Fault	Ok	Fault	Ok
Track Any Input Fault	Fault	Ok	Fault	Ok
Track Input Group	Initiated Stop	Other Input Caused Stop	Initiated Stop	Other Input Caused Stop
Track Output	SO ON	SO OFF	SO ON	SO OFF
Track Output Fault	Fault	Ok	Fault	Ok
Track Output Fault All	Fault	Ok	Fault	Ok
Track Output Logical State	Logically ON	Logically OFF	Logically ON	Logically OFF
Track Function Block State (XS/SC26 FID 2 or later and SC10-2)	Run	Stop	Run	Stop
Track Press Function Block (XS/SC26 FID 4 or later)	See Press Control Status Output Functionality on page 80 for details.			
Waiting for Manual Reset	Reset Needed	Not Satisfied	Reset Needed	Not Satisfied
System Lockout	Lockout	Run Mode	Lockout	Run Mode

7.9.2 Status Output Functionality

SC10-2: Up to four convertible inputs may be used as Status Outputs.

XS/SC26: Up to 32 convertible inputs or safety outputs may be used as status outputs. Solid-state safety outputs may be split and used as status outputs. Relay safety outputs cannot be used as status outputs and cannot be split.

Status outputs can be configured to perform the following functions:

Bypass

Indicates when the input to the Bypass function block is bypassed.

Mute

Indicates a muting active status for the input to the particular Muting function block:

- ON when a mutable input is muted
- OFF when a mutable input is not muted
- Flashing when the conditions to start a mute-dependent override exist (an inactive muting cycle, the Mutable Safety input is in the stop state, and at least one muting sensor is in the stop (blocked) state); not available for Virtual Status Output
- ON during an active mute-dependent override function (not a bypass function) of a Mutable Safety input

Output Delay In Progress

Indicates when either an ON- or OFF-Delay is active.

Track Input

Indicates the state of a particular safety input.

Track Input Fault

Indicates when a particular safety input has a fault.

Track Any Input Fault

Indicates when any safety input has a fault.

Track Input Group

Indicates the state of a group of safety inputs, for example, which safety input turned off first. Once this function has been indicated, the function may be re-enabled by a configured Reset input. Up to three Input Groups can be tracked.

Track Output

Indicates the physical state of a particular safety output (ON or OFF).

Track Output Fault

Indicates when a particular safety output has a fault.

Track Output Fault All

Indicates a fault from any safety output.

Track Output Logical State

Indicates the logical state of a particular safety output. For example, the logical state is OFF but the safety output is in an OFF-Delay and not physically off yet.

Track Function Block State (XS/SC26 FID 2 or later and SC10-2)

Indicates the state of a particular function block.

Track Press Function Block (XS/SC26 FID 4 or later)

Indicates the state of a number of Press Function events; see [Press Control Status Output Functionality](#) on page 80 for details.

Waiting for Manual Reset

Indicates a particular configured reset is needed.



Note: If the manual reset input is connected to a Reset OR block, this status output cannot be used.

System Lockout

Indicates a non-operating lockout condition, for example unmapped input connected to 24 V.

7.9.3 Press Control Status Output Functionality

This feature is available on XS/SC26 FID 4 and later.

The Press Control function block has multiple inputs and outputs. This results in a status output function that is not a simple on/off for an individual item. The status output of the Press Control block has seven different events that can be signaled via the status output. The status output of the Press Control block can be configured to provide one, two, or three signals. Each signal from the status output of the Press Control block can be as follows:

- Solid On
- 2 pulses per second

Figure 52. 2 Pulses Per Second

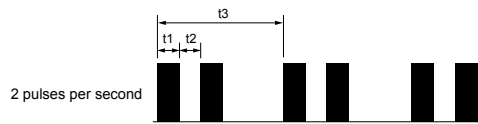

t1 = 100 ms, t2 = 100 ms, and t3 = 1 second

- 3 pulses per second

Figure 53. 3 Pulses Per Second

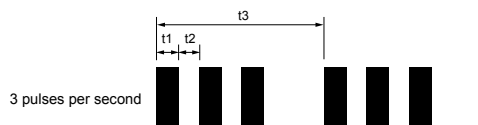

t1 = 100 ms, t2 = 100 ms, and t3 = 1 second

The Press Control block status output is only available as physical status outputs. Each physical status output can be used to signify three different events.

The following figure shows the default settings of the status output of the Press Control function block:

Figure 54. Track Press Function Block Properties

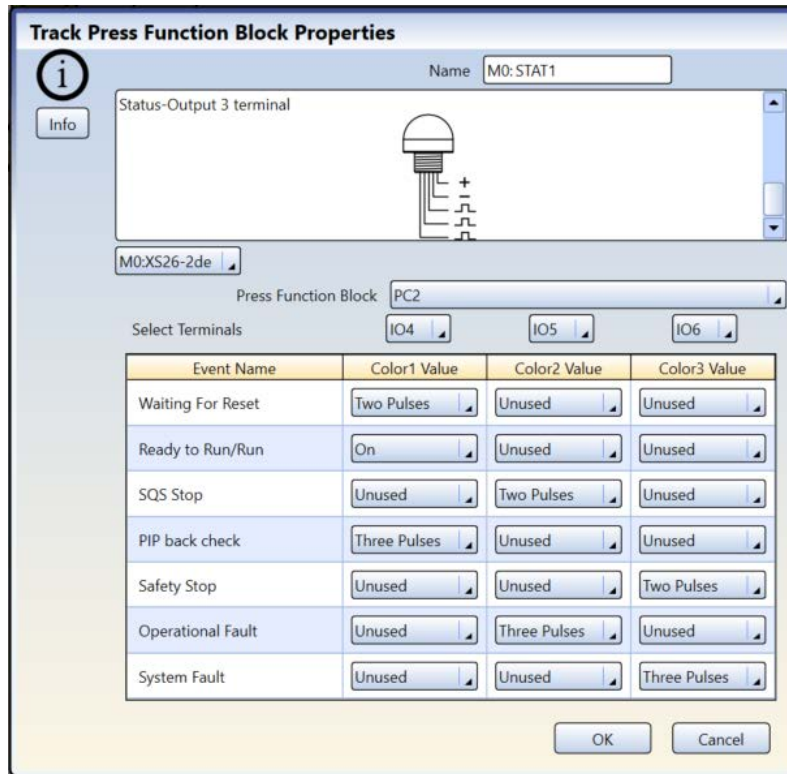

The default setting of the function block configures three of the IO pins as status outputs. If all seven events are not required to be displayed for a given application, use the slide bar on the right of the figure to select fewer pins. Moving the bar up one position reduces the number of terminals to two, moving the bar up two positions reduces the number of terminals to one.

The functionality of each event is as follows:

- **Waiting for Reset**—Turns on when a reset input is needed, after the non-mutable and mutable (if configured) safety stop inputs return to the ON state
- **Ready to Run/Run**—Is on any time the press is ready to run (mutable and non-mutable safety stop inputs are on and reset) or the press is running in the up or down stroke
- **SQS Stop**—Turns on when the press ram reaches the Sequence Stop point
- **PIP back check alert**—Turns on when the press is ready to run and an attempt is made to start a press cycle and the PIP (Part in Place) input, if configured, is off or has not turned off then back on (part not removed and replaced)
- **Safety Stop**—Turns on when either the mutable or non-mutable safety stop input turns off, the GO input node goes low (when configured for Manual Upstroke Setting) before SQS, BOS, or TOS is reached (depending on settings and portion of the process)
- **Operational Fault**—Turns on when mutually exclusive operational inputs are on (for example, TOS and BOS, TOS and SQS, TOS and PCMS, SQS and BOS, etc; if more than 3 seconds elapse between the SQS and PCMS signals both turn on, if configured)
- **System Fault**—Turns on when a system fault exists

7.10 Virtual Status Outputs

Up to 64 Virtual Status Outputs can be added for any configuration using Modbus TCP, EtherNet/IP Input Assemblies, EtherNet/IP Explicit Messages, and PCCC protocols on FID 1 XS/SC26 Safety Controllers and up to 256 Virtual Status Outputs can be added on FID 2 or later XS/SC26 Safety Controllers and SC10-2 Safety Controllers. FID 2 or later XS/SC26 Safety Controllers and SC10-2 Safety Controllers can also use PROFINET. FID 6 or later expandable, Ethernet-enabled XS26 Safety Controllers can also use EtherCAT when the XSeCAT Communication Gateway module is added. These outputs can communicate the same information as the Status Outputs over the network. See [Status Output Functionality](#) on page 79 for more information. The **Auto Configure** function, located on the **Industrial Ethernet** tab of the Software, automatically configures the Virtual Status Outputs to a set of commonly used functions, based on the current configuration. This function is best used after the configuration has been determined. Virtual Status Output configuration can be manually revised after the **Auto Configure** function has been used. The information available over the network is consistent with the logical state of the inputs and outputs within 100 ms for the Virtual Status Output tables (viewable via the Software) and within 1 second for the other tables. The logical state of inputs and outputs is determined after all internal debounce and testing is complete. See [Industrial Ethernet Tab](#) on page 117 for details on configuring Virtual Status Outputs.

ISD chains and individual device performance and status can be obtained from FID 2 or later SC10-2 Safety Controllers and FID 5 or later XS26-ISD Safety Controllers. Sixteen (16 bit) words can be obtained about the status of each chain. Three (16 bit) administrative words and 18 bytes (8 bits each) of specific data on an individual device of a chain can be obtained. See [Request Performance and Status Information about an Individual Device via ISD](#) on page 50 for more details.

8 Getting Started

Power up the Safety Controller, and verify that the power LED is ON green.

8.1 Creating a Configuration

The following steps are required to complete and confirm (write to controller) the configuration:

1. Define the safeguarding application (risk assessment).
 - Determine the required devices
 - Determine the required level of safety
2. Install the Banner Safety Controller software. See [Installing the Software](#) on page 29.
3. Become familiar with the Software options. See [Software Overview](#) on page 103.
4. Start the Software and select the desired device.
5. Start a new project by clicking **New Project/Recent Files**.
6. Define the **Project Settings**. See [Project Settings](#) on page 105.
7. XS/SC26: Customize the Base Controller and add Expansion Modules and/or a Communication Gateway (if used). See [Equipment Tab](#) on page 106.
8. Add Safety Input devices, Non-Safety Input devices, and Status Outputs. See [Adding Inputs and Status Outputs](#) on page 83.
9. Design the control logic. See [Designing the Control Logic](#) on page 88.
10. Set optional Safety Output On- or Off-time delays.
11. If used, configure the network settings. See:
 - [Network Settings: Modbus TCP, Ethernet/IP, PCCC](#) on page 120
 - [Network Settings: PROFINET](#) on page 121
 - [Network Settings: EtherCAT](#) on page 121
12. Save and confirm the configuration. See [Saving and Confirming a Configuration](#) on page 89.

The following steps are optional and may be used to aid with the system installation:

- Modify the configuration access rights. See [XS/SC26 Password Manager](#) on page 125 or [SC10-2 Password Manager](#) on page 126.
- View the **Configuration Summary** tab for the detailed device information and response times. See [Configuration Summary Tab](#) on page 123.
- Print the configuration views, including the **Configuration Summary** and **Network Settings**. See [Print Options](#) on page 124.
- Test the configuration using Simulation Mode. See [Simulation Mode](#) on page 131.

8.2 Adding Inputs and Status Outputs

Safety and Non-Safety Inputs can be added from either the **Equipment** tab or the **Functional View** tab. Status Outputs can be added from the **Equipment** tab only. Virtual Non-Safety inputs can be added from the **Functional View** tab only. When inputs are added on the **Equipment** tab, they are automatically placed in the **Functional View** tab. All inputs and **Logic** and **Function Blocks** can be moved around on the **Functional View** tab. The **Safety Outputs** are statically positioned on the right side.

8.2.1 Adding Safety and Non-Safety Inputs

1. On the **Equipment** tab, click  below the module which will have the input device connected (the module and terminals can be changed from the input device **Properties** window) or any of the placeholders on the **Functional View** tab.



Note: Virtual Non-Safety Inputs are available only from the **Functional View** tab.

2. Click **Safety Input** or **Non-Safety Input** to add input devices:

Figure 55. XS/SC26: Adding inputs from the Functional View (Virtual Non-Safety Inputs can only be added from this view)



Figure 56. SC10-2: Adding inputs from Equipment View (physical status output can only be added from this view)

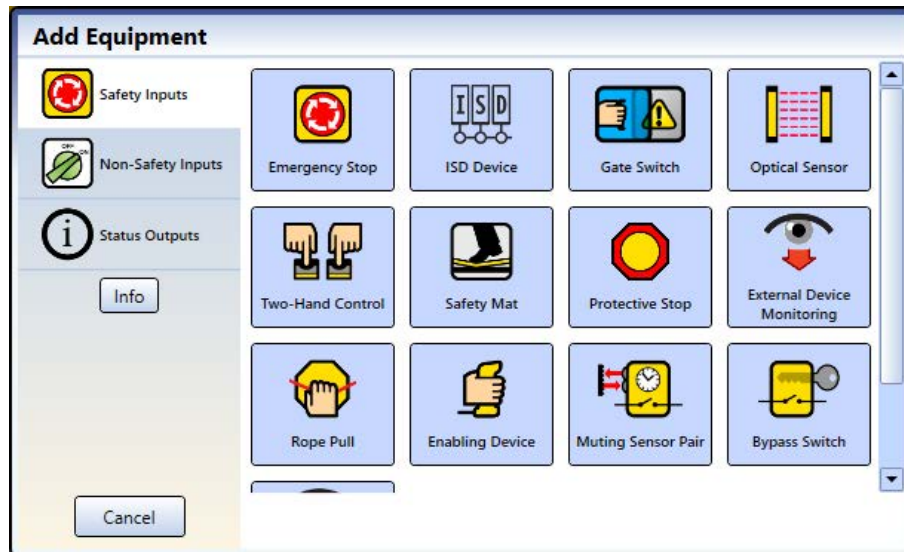
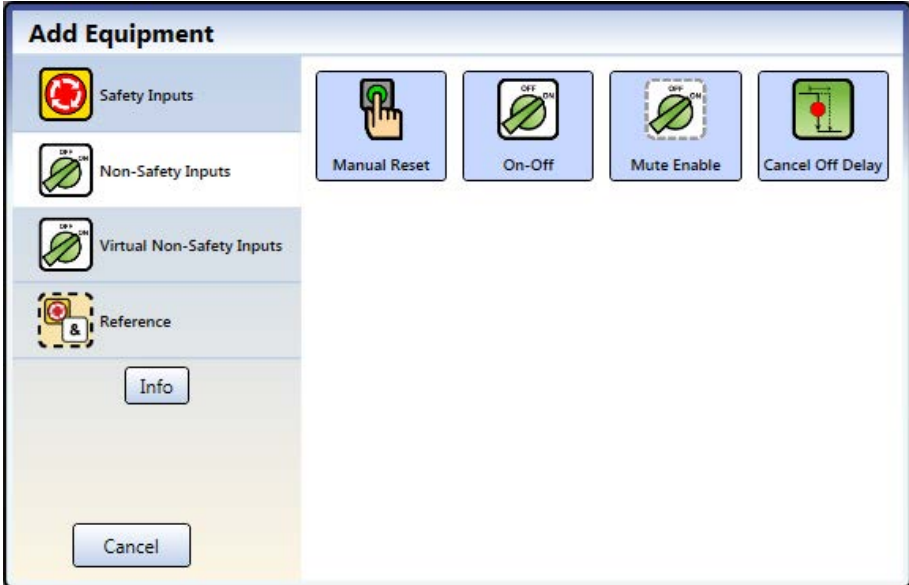

Figure 57. Non-Safety Inputs (Virtual Non-Safety Inputs available only from the **Functional View Tab**)



3. Select appropriate device settings:

Basic settings:

Figure 58. Basic Safety Input Settings

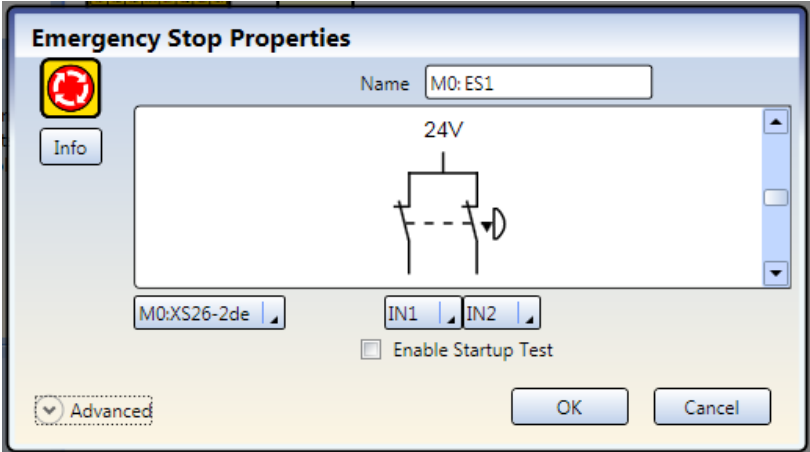

- **Name**—input device name; generated automatically and can be changed by the user. Names can be a maximum of 10 characters. When shown on the display of display models, a maximum of 8 characters are shown (due to size constraints)
- **Circuit Type**—the circuit and signal convention options appropriate for the selected input device; scroll to see and select the desired option
- **Module**— the module to which the input device is connected (for example, M0:XS26-2e)
- **I/O Terminals**—the assignment of input terminals for the selected device on the selected module
- **Enable Startup Test** (where applicable)—an optional precautionary safety input device test required after each power-up
- **Reset Options** (where applicable)—various reset options such as Manual Power Up, System Reset, and Reset Track Input Group

Advanced settings (where applicable):

Figure 59. Advanced Safety Input Settings

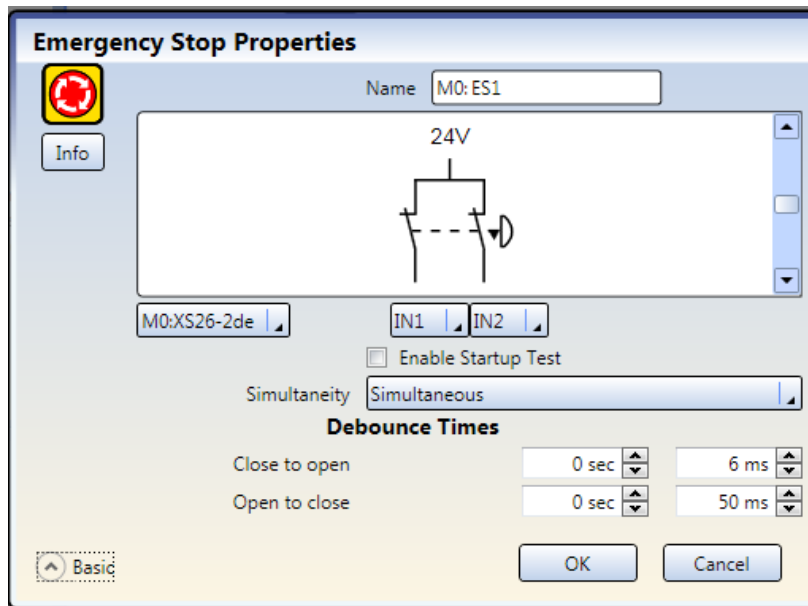

- *Simultaneity* (where applicable)—Simultaneous or Concurrent (see [Glossary](#) on page 347 for definitions)
- *Debounce Times*—the signal state transition time
- *Monitored/Non-Monitored* (where applicable)—see [Reset Signal Requirements](#) on page 60

ISD Device Properties (where applicable):

Figure 60. Advanced ISD Device Settings

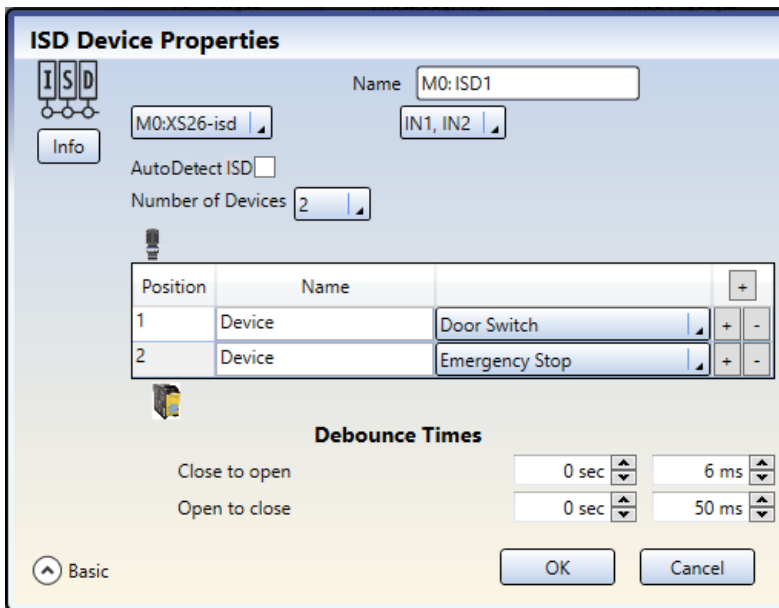

- *Name*—input device name; generated automatically and can be changed by the user. Names can be a maximum of 10 characters. When shown on the display of display models, a maximum of 8 characters are shown (due to size constraints)
- *I/O Terminals*—the assignment of input terminals for the selected device on the selected module
- *Number of Devices (required)*—the number of ISD sensors used in the application
- *AutoDetect ISD (where applicable)*—option where, when selected, the controller actively determines the number of devices and their types during operation. For more information, see [AutoDetect ISD Option](#) on page 313.
- *Manual Baseline at Power Up (where applicable)*—option where, when selected, the controller will set the 'Re-baseline' bit to the software and/or connected PLC. The 'Accept this Baseline' bit must be returned to the controller to accept and set the current configuration as the startup baseline. The **Manual Baseline at Power Up** checkbox is available when the **AutoDetect ISD** checkbox is selected.
- *Position, Name, and Type*—the position, name, and type (Door Switch, E-Stop, ISD-Connect) of ISD sensors used in the application. The **Name** is generated automatically and can be changed by the user. The **Type** is a user-selectable menu
- *Debounce Times*—the signal state transition time

Note: The Banner Safety Controller Software applies the gate switch rules to the ISD Inputs.

8.2.2 Adding Status Outputs

1. On the **Equipment** tab, click below the module which will have the status monitoring.
2. Click **Status Outputs** to add status monitoring ¹⁷.

¹⁷ Status outputs can be configured when the state of an input device or an output needs to be communicated. The IOx terminals are used for these status signals.

Figure 61. Status Outputs

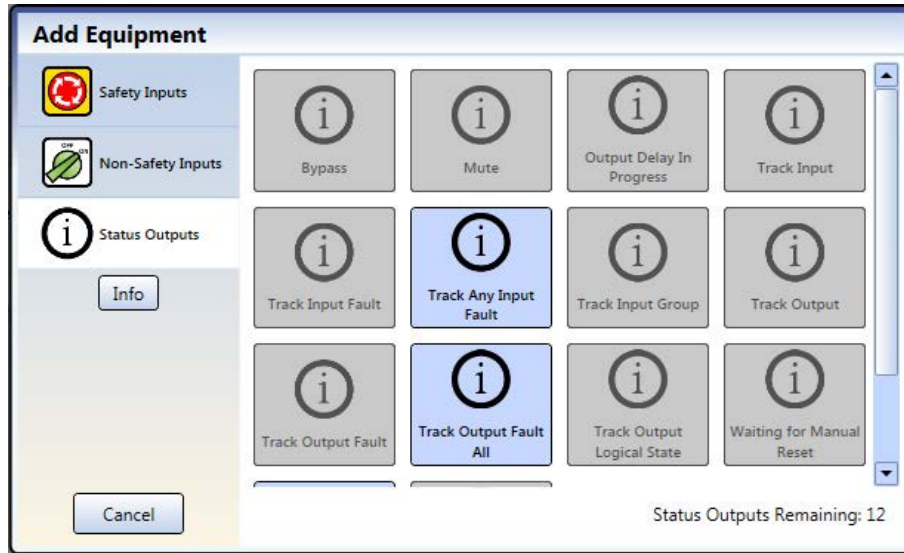

3. Select appropriate Status Output settings:

Figure 62. Status Output Properties

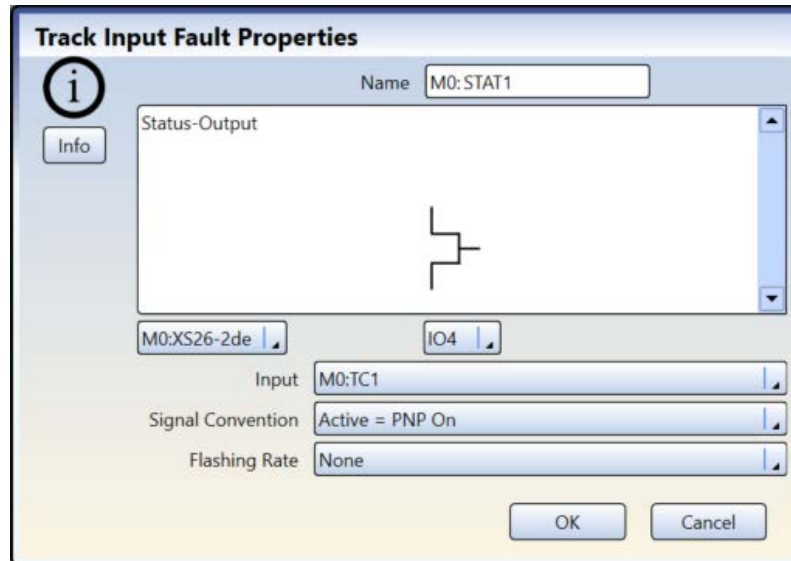

- *Name*—Names can be a maximum of 10 characters. When shown on the display of display models, a maximum of 8 characters are shown (due to size constraints)
- *Module*
- *I/O (where applicable)*
- *Terminal*
- *Input or Output (where applicable)*
- *Signal Convention*
- *Flashing Rate*

8.3 Designing the Control Logic

To design the control logic:

1. Add the desired **Safety** and **Non-Safety** Inputs:

- On the **Equipment** tab: click  under the module to which the input will be connected (the module can be changed in the input **Properties** window)
- On the **Functional View** tab: click any of the empty placeholders in the left column

See [Adding Inputs and Status Outputs](#) on page 83 for more information and device properties.

2. Add **Logic** and/or **Function Blocks** (see [Logic Blocks](#) on page 108 and [Function Blocks](#) on page 110) by clicking any of the empty placeholders in the middle area.



Note: The response time of the Safety Outputs can increase if a large number of blocks are added to the configuration. Use the function and logic blocks efficiently to achieve the optimum response time.

3. Create the appropriate connections between added inputs, **Function** and **Logic Blocks**, and Safety Outputs.



WARNING:

- **Configuration Conforms to Applicable Standards**
- Failure to verify the application may result in serious injury or death.
- The Banner Safety Controller Software primarily checks the logic configuration for connection errors. The user is responsible for verifying the application meets the risk assessment requirements and that it conforms to all applicable standards.



Note: The checkList on the left displays connections that are required for a valid configuration and all items must be completed. The Safety Controller will not accept an invalid configuration.



Note: The output node of any item can be connected to multiple input nodes. An input node can only have one item connected to it.



Tip: To aid with creating a valid configuration, the program displays helpful tooltips if you attempt to make an invalid connection.

8.4 Saving and Confirming a Configuration

Confirmation is a verification process where the Safety Controller analyzes the configuration generated by the Software for logical integrity and completeness. The user must review and approve the results before the configuration can be saved and used by the Safety Controller. Once confirmed, the configuration can be sent to a Safety Controller or saved on a PC or an SC-XM2/3 drive.



WARNING:

- **Complete the Commissioning Checkout Procedure**
- Failure to follow the commissioning process may lead to serious injury or death.
- After confirming the configuration, the Safety Controller operation must be fully tested (commissioned) before it can be used to control any hazards.

8.4.1 Saving a Configuration

1. Click  **Save Project**.
2. Select **Save As**.
3. Navigate to the folder where you wish to save the configuration.
4. Name the file (may be the same or different from the configuration name).
5. Click **Save**.



Note: If the configuration has not been configured, this process saves the configuration as an unconfirmed configuration (a *.xsc file).

8.4.2 Confirming a Configuration

The Safety Controller must be powered up and connected to the PC via the SC-USB2 cable.

1. Click .
2. Click **Write Configuration to Controller**.

If the configuration has not been saved, the software will ask if you want to save the project (configuration). This saves the unconfirmed configuration. Selecting **Save** saves the file with the current name. Selecting **Don't Save** continues the writing process.

Figure 63. "Do you want to save?" Message

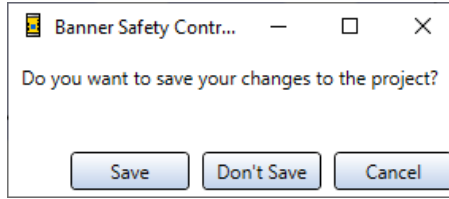

If the configuration being sent to the controller contains item(s) that are not supported by the attached controller (for example, expansion modules, virtual inputs, ISD inputs, etc.), the following notice displays:

Figure 64. Incompatible Controller Warning



This notice is a reminder that the configuration can be loaded into the attached controller, but it will not function (controller will lockout). The configuration is allowed to be loaded because during this process the configuration can also be confirmed. It will not run on this controller, but this now confirmed configuration can be loaded onto an SC-XM2/3 or e-mailed to a remote location, and then can be loaded onto a compatible controller. If the configuration is already confirmed, it is still allowed to be loaded onto the attached controller. However, after it is loaded, the controller will lock out because the configuration contains unsupported features.

3. If prompted, enter the password (default password is 1901).
The **Entering config-mode** screen opens.
4. Click **Continue** to enter the configuration mode.
After the **Reading Configuration from the Controller** process is completed, the **Confirm Configuration** screen opens.
5. Verify that the configuration is correct.
6. **Scroll to the end of the configuration and click Confirm.**
7. After the **Writing Configuration To Controller** process is completed, click **Close**.



Note:

- Network settings are sent separately from the configuration settings. Click **Send** from the **Network Settings** window to write the network settings to the Safety Controller.
- SC10-2 and XS/SC26 FID 3 or later: Network settings are automatically sent only if the Safety Controller is a factory default Safety Controller. Otherwise, use the **Network Settings** window.
- SC10-2 and XS/SC26 FID 3 or later: Passwords are automatically written only if the Safety Controller is a factory default Safety Controller or the configuration is confirmed. In any other case, use the **Password Manager** window to write passwords to the Safety Controller.

If you are configuring an SC10-2 or XS/SC26 FID 3 or later, the **Do you want to change the passwords of the controller?** screen may display.

8. SC10-2 and XS/SC26 FID 3 or later: If prompted and if desired, change the passwords.
9. Cycle power or perform a System Reset for the changes to take effect in the Safety Controller.
10. Save the confirmed configuration on the PC.



Note: Saving the now confirmed configuration is recommended. Confirmed configurations are a different file format (.xcc) than an unconfirmed file (.xsc). Confirmed configurations are required for loading into an SC-XM2/3 drive. Click **Save As** to save.

8.4.3 Write a Confirmed Configuration to an SC-XM2/3 using the Programming Tool

1. Insert the SC-XM2/3 into the SC-XMP2 programming tool.
2. With the Banner Safety Controller software running, insert the programming tool into a USB port of the PC. The SC-XM2/3 icon should go live (become a bit darker than grayed out).
3. Click  and select **Write XM**.



Note: If **Write XM** is grayed out, the configuration is not a .xcc (confirmed version).

4. Verify the desired passwords.
5. Click **Send to XM**.
The **Writing Configuration to SC-XM drive** window opens.



Note: This process copies all data (configuration, network settings, and passwords) to the SC-XM2/3 drive.

6. After it is finished, click **Save Confirmed Configuration** and then **Close**, or click **Close** if the file has already been saved to the PC.

8.4.4 Notes on Confirming or Writing a Configuration to a Configured SC10-2 or XS/SC26 FID 3 or later

User settings and passwords affect how the system responds when confirming a configuration or writing a confirmed configuration to a configured SC10-2 or XS/SC26 FID 3 or later Safety Controller.

User1

1. Click **Write configuration to Controller** to confirm a configuration (or write a confirmed configuration) to a configured Safety Controller.
2. Enter the User1 password.
3. The confirmation (or writing) process begins.

At the end of the confirmation (or writing) process, the Safety Controller will have received:

- New passwords
- New configuration

Network settings are not changed.

User2 or User3—Successful Configuration Confirmation or Writing

This scenario assumes the following settings for User2 or User3:

- **Allowed to change the configuration** = enabled
 - **Allowed to change the network settings** = enabled OR disabled
1. Click **Write configuration to Controller** to confirm a configuration (or write a confirmed configuration) to a configured Safety Controller.
 2. Enter the User2 or User3 password.
 3. The confirmation (or writing) process begins.

At the end of the confirmation (or writing) process, the Safety Controller will have received:

- New configuration

Passwords and Network settings are not changed.

User2 or User3—Unsuccessful Configuration Confirmation or Writing

This scenario assumes the following settings for User2 or User3:

- **Allowed to change the configuration** = disabled
 - **Allowed to change the network settings** = enabled OR disabled
1. Click **Write configuration to Controller** to confirm a configuration (or write a confirmed configuration) to a configured Safety Controller.
 2. Enter the User2 or User3 password.
 3. The confirmation (or writing) process is aborted.

8.5 Sample Configurations

The Software provides several sample configurations that demonstrate various features or applications of the Safety Controller. To access these configurations, go to **Open Project > Sample Projects** and select the desired project.

The XS/SC26 has three groupings of sample configurations:

- **Applications**—Includes samples of simple potential applications of the controller. Two of the samples are obsolete module replacement.
- **Documentation**—Includes samples. Most of the samples included here are described in the following sections, and one is described in the Quick Start Guide (available online).
- **Examples**—Includes three divisions: **Function Blocks**, **Logic Blocks**, and **Safety Outputs**. These examples show the functionality of the various blocks. For example, to see how a bypass block operates, select **Function Blocks > Bypass Block (All Features Enabled)** and run it in Simulation Mode.

The SC10-2 has several sample configurations. These samples include typical applications of the SC10-2 model. Use the samples as a starting point and modify them for your specific needs.

8.5.1 XS/SC26 Sample Configuration

This section describes designing the sample configuration "3 Zone Muting Instruction Manual", which is located under the **Documentation** section of the XS/SC26 sample programs. This sample configuration is for a robotic palletizer application that utilizes an XS26 Safety Controller, XS8si Safety Input Module, three optical sensors (muting is added via the software), two interlock switches, a manual reset, and an Emergency Stop button.

Figure 65. Sample Configuration Schematic

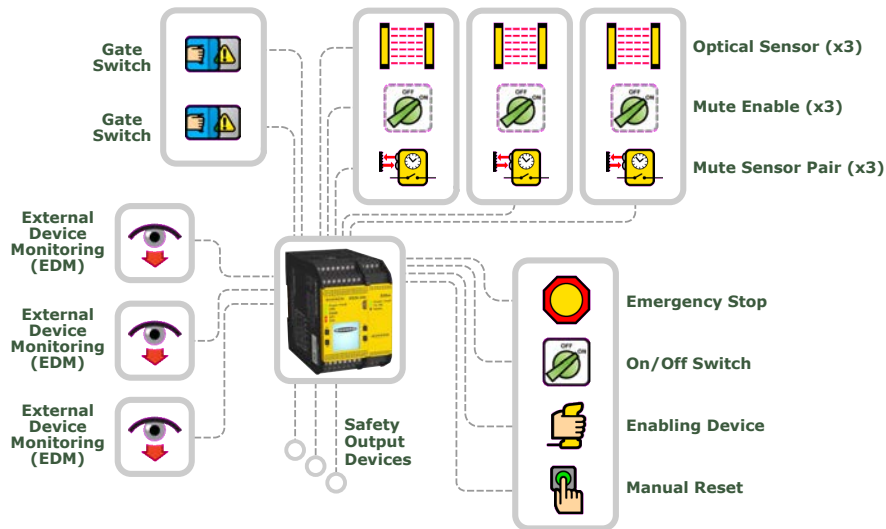

To design the configuration for this application:

1. Click **New Project**.
2. Define project settings. See [Project Settings](#) on page 105.
3. Select Base Controller model. See [Equipment Tab](#) on page 106 (for this configuration, only the **Is Expandable** box is required to be checked).
4. Add the expansion module **XS8si** by clicking on **+** to the right of the Base Controller.
 - a. Click **Input Modules**.
 - b. Select **XS8si**.
5. Add the following inputs, changing only the circuit type:

Input	Quantity	Type	Module	Terminals	Circuit
Emergency Stop	1	Safety Input	XS8si	IO1, IN1, IN2	Dual-Channel 3 terminal
Enabling Device	1	Safety Input	XS8si	IO1, IN3, IN4	Dual-Channel 3 terminal

Input	Quantity	Type	Module	Terminals	Circuit
External Device Monitoring	3	Safety Input	Base	1. IO3 2. IO4 3. IO5	Single-Channel 1 terminal
Gate Switch	2	Safety Input	Base	1. IO1, IN15, IN16 2. IO2, IN17, IN18	Dual-Channel 3 terminal
Manual Reset	1	Non-Safety Input	XS8si	IN6	Single-Channel 1 terminal
Muting Sensor Pair	3	Safety Input	Base	1. IN9, IN10 2. IN11, IN12 3. IN13, IN14	Dual-Channel 2 terminal
Mute Enable	3	Non-Safety Input	Base	1. IN1 2. IN2 3. IO8	Single-Channel 1 terminal
On-Off	1	Non-Safety Input	XS8si	IN5	Single-Channel 1 terminal
Optical Sensor	3	Safety Input	Base	1. IN3, IN4 2. IN5, IN6 3. IN7, IN8	Dual-Channel PNP

6. Go to the **Functional View** tab.



Tip: You may notice that not all inputs are placed on Page 1. There are two solutions to keep the configuration on one page. Perform one of the following steps:

1. Add a **Reference** to the block located on a different page—click any of the empty placeholders in the middle area, select **Reference** and select the block that is on the next page. Only blocks from other pages can be added as a **Reference**.
2. Re-assign page—by default all inputs added on the **Equipment** tab are placed on the **Functional View** tab to the first available placeholder in the left column. However, inputs can be moved to any location in the middle area. Move one of the blocks to any of the placeholders in the middle area. Go to the page which contains the block that needs to be moved. Select the block and change the page assignment below the **Properties** table.

7. Split **M0:SO2**:
- a. Double-click **M0:SO2** or select it and click **Edit** under the **Properties** table.
 - b. Click **Split**.
8. Add the following **Function Blocks** by clicking on any of the empty placeholders in the middle area of the **Functional View** tab (see [Function Blocks](#) on page 110 for more information):
- **Muting Block** x 3 (**Muting Mode**: One Pair, **ME (Mute Enable)**: Checked)
 - **Enabling Device Block (ES)**: Checked, **JOG (Jog)**: Checked)
9. Add the following **Logic Blocks** by clicking on any of the empty placeholders in the middle area of the **Functional View** tab (see [Logic Blocks](#) on page 108 for more information):
- **AND** with 2 input nodes
 - **AND** with 4 input nodes
10. Connect the following to each **Muting Block**:
- 1 x **Optical Sensor (IN)** node)
 - 1 x **Mute Sensor Pair (MP1)** node)
 - 1 x **Mute Enable (ME)** node)
11. Connect **Gate Switch** x 2 to the **AND** block with 2 nodes.
12. Connect **Muting Block** x 3, and **AND** block with 2 nodes to the **AND** block with 4 nodes.
13. Connect one of the **Muting Blocks** to one of the split safety outputs (**M0:SO2A** or **M0:SO2B**) and one to the other split safety output.
14. Connect the following to the **Enabling Device Block**:
- **Emergency Stop (ES)** node)
 - **Enabling Device (ED)** node)
 - **AND** block with four input nodes (**IN** node)
 - **Manual Reset (RST)** node)
 - **On-Off (JOG)** node)
15. Connect **Enabling Device Block** to the remaining Safety Output (**M0:SO1**).

16. Enable *EDM (External Device Monitoring)* in each of the Safety Output **Properties** windows.
17. Connect 1x **External Device Monitoring** input to each of the Safety Outputs.

The Sample Configuration is complete.



Note: At this point you may want to reposition the blocks in the **Functional View** tab for a better configuration flow, as shown in the following figure:

Figure 66. Sample Configuration—Functional View Tab

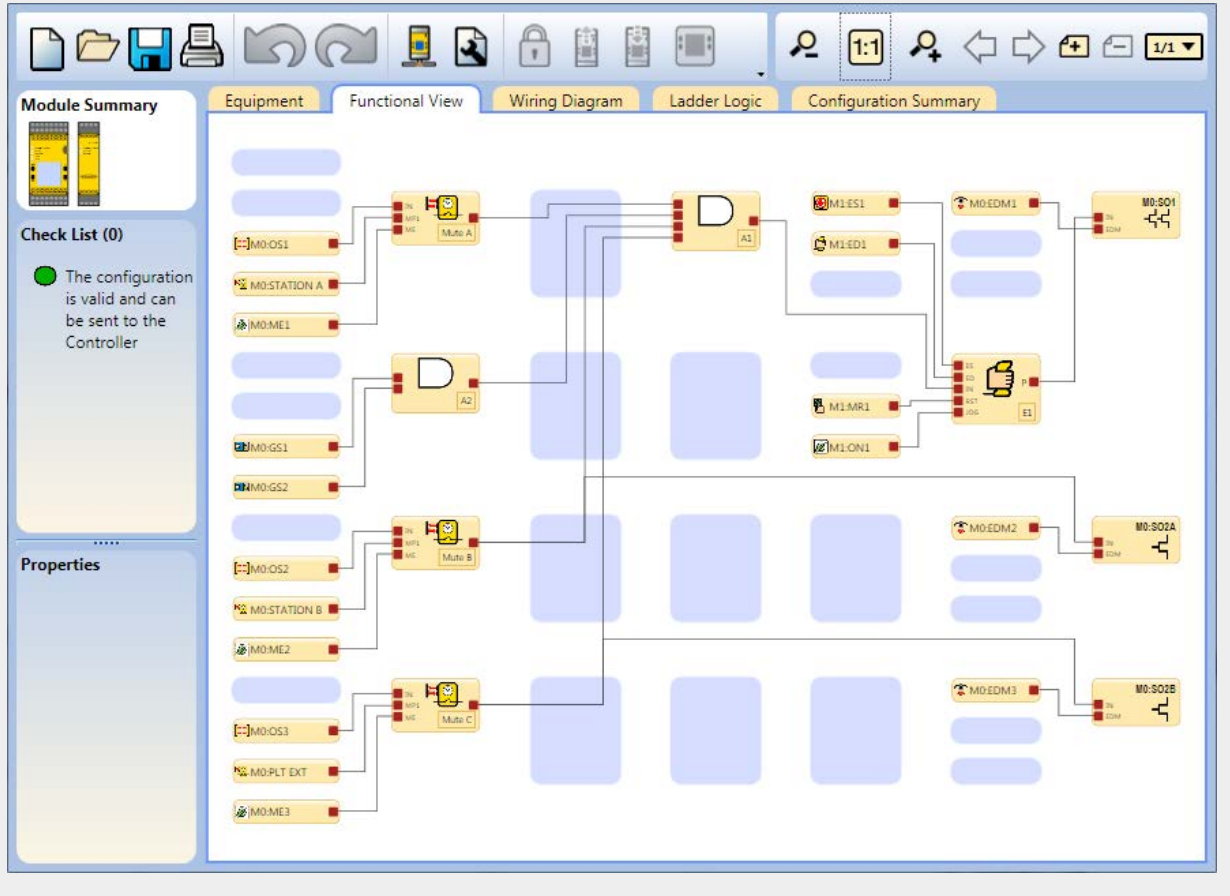

8.5.2 XS/SC26: Simple Press Control with Mutable Safety Input Sample Configuration

This section describes designing a simple press control system, which is located under the Documentation section of the XS/SC26 sample programs.

This sample configuration is for a simple hydraulic/pneumatic press application that utilizes a XS26 Safety Controller, Press Status inputs, a Cycle Initiation, a manual reset, an optical safety sensor, and an emergency stop.

Figure 67. Simple Sample Press Control Configuration

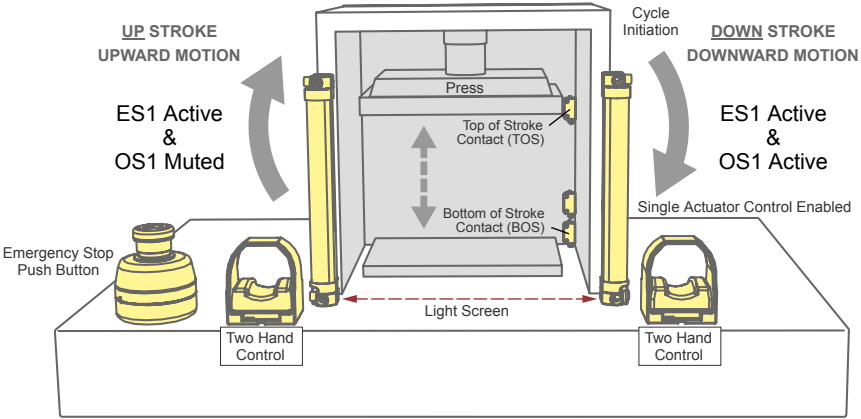

To design the configuration for this application:

1. Click **New Project**.
2. Define the project settings.
See [Project Settings](#) on page 105.
3. Select the desired Base Controller model.
See [Equipment Tab](#) on page 106.
4. Add the following inputs, changing name and circuit type as needed.

Input	Quantity	Type	Terminals	Circuit
Cycle Initiation	1	Safety Input	IN1, IN2	Dual-Channel 2 Terminal
TOS (on/off)	1	Non-Safety	IN5	Single-Channel 1 Terminal
BOS (on/off)	1	Non-Safety	IN6	Single-Channel 1 Terminal
Manual Reset	1	Non-Safety	IN7	Single-Channel 1 Terminal
Emergency Stop	1	Safety Input	IN10, IN11	Dual-Channel 2 Terminal
Optical Sensor	1	Safety Input	IN8, IN9	Dual-Channel PNP

5. Go to the **Functional View** tab.
6. Add and configure the Press Control function block.
 - a) Click on any of the empty placeholders in the middle area of the **Functional View** tab. For more information, see [Function Blocks](#) on page 110.
 - b) Select **Function Blocks** and select **Press Control**.
 - c) In the **Press Control Properties** window, select **PCI (Press Control Input Function Block)** and **Single Actuator Control**.

Figure 68. Press Control Properties

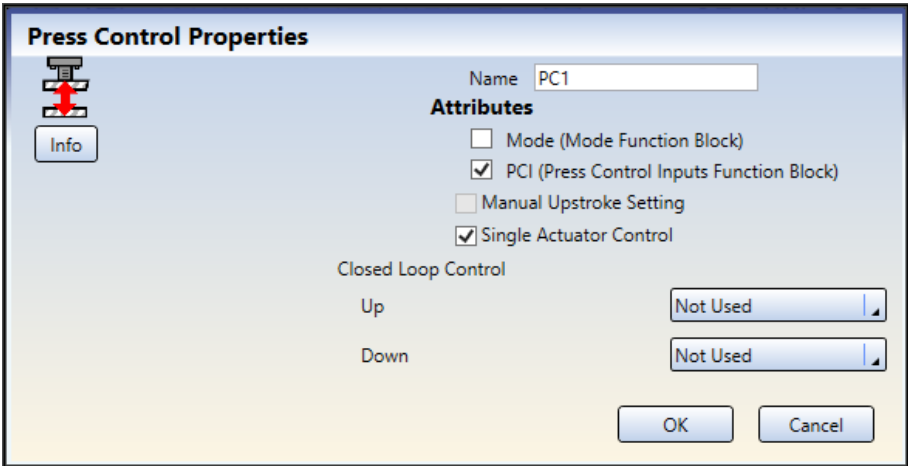

- The check in the **Manual Upstroke Setting** box disappears.
- d) Click **OK**.
- The **Press Control Inputs Properties** window opens.

Figure 69. Press Control Inputs Properties

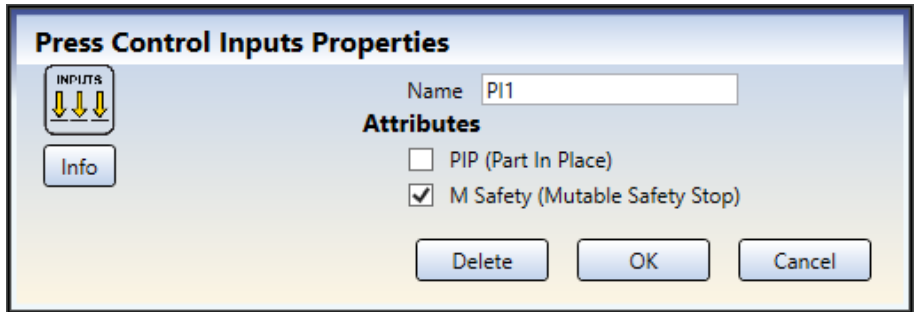

- e) Select **M Safety (Mutable Safety Stop)**.
 - f) Click **OK**.
7. Connect the following:
- Cycle Initiation input to the GO node of the Press Control function block
 - TOS to the TOS node of the Press Control function block
 - BOS to the BOS node of the Press Control function block
 - Manual Reset to the RST node of the Press Control function block
 - Emergency Stop to the NM Safety node of the Press Control function block
 - Optical Sensor to the M Safety node of the Press Control Input Function Block
8. Connect the U output node of the Press Control function block to SO1 (change the name of SO1 to "Up Stroke").
9. Connect the D output node of the Press Control function block to SO2 (change the name of SO2 to "Dwn Strk").

The sample configuration is complete.



Note: At this point, it can be helpful to reposition the blocks in the Functional View for better configuration flow, as shown in the following figure:

Figure 70. Function Block Position

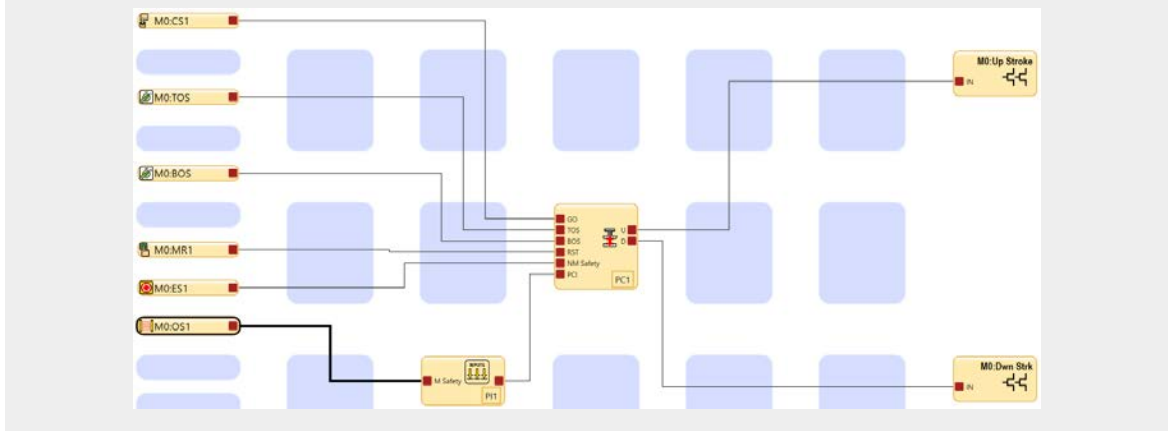

XS/SC26: Simulate the Functionality of the Simple Press Control Configuration

The following is how to simulate the functionality of the simple press control configuration:

1. Click to enter Simulation Mode.
2. Click **Play** to turn on the simulation timer (similar to powering on the machine).
3. Click the emergency stop, optical sensor, and TOS inputs to the ON state (green).
4. Click the MR1 reset input.
The Press Control Function block should turn ON (green).
5. Click the CS1 input to the ON state (green).
The Dwn Strk output turns ON (green).

6. Click the TOS input to the OFF state (red).
7. Click the BOS input to the ON state (green).
The Dwn Strk output turns OFF (red) and the Up Stroke Output turn ON (green).
8. Click the BOS input OFF (red).
9. Click the TOS input to the ON state (green).
The Up Stroke Output turns OFF (red).
10. Click the CS1 input to the OFF state (red). This can be done any time after the Dwn Strk output turns ON (green).
11. Click the Optical Sensor input to the OFF state (red), then back to the ON state (green).

The system is ready to start the next cycle by turning the CS1 input on again.

If the Optical sensor or E-stop are turned OFF during the up or down stroke, the MR1 input must be cycled, then the CS1 engaging will turn the Up Stroke output ON.

8.5.3 XS/SC26: Full Feature Press Control Sample Configuration

This section describes designing a press control system that uses all of the possible features (except AVM). The sample configuration is located under the Documentation section of the XS/SC26 sample programs.

This sample configuration is for a more complex hydraulic/pneumatic press application that uses a XS26 Safety Controller, XS2so Safety Output Module, Press Status inputs, cycle start, a manual reset, an optical safety sensor, sequential stop, mute sensor, Foot Switch input, and an Emergency Stop button.

Figure 71. Full Feature Sample Press Control Configuration

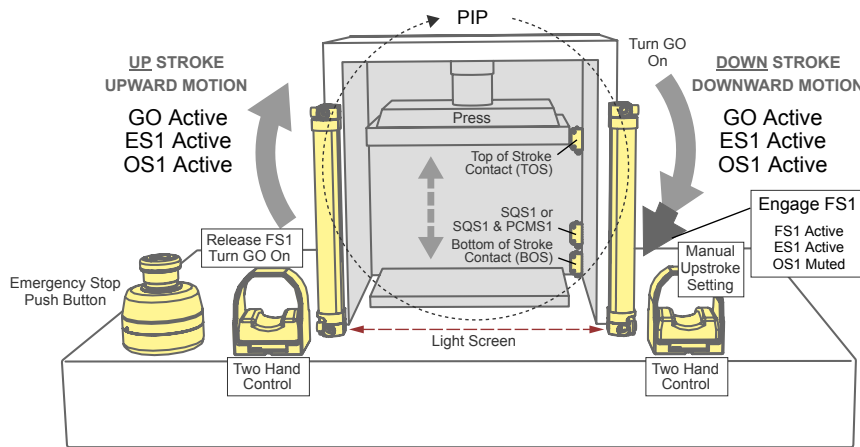

To design the configuration for this application:

1. Click **New Project**.
2. Define the project settings.
See [Project Settings](#) on page 105.
3. Select the desired Base Controller model.
See [Equipment Tab](#) on page 106 (for this configuration, only **Is Expandable** is required to be selected).
4. Add expansion module XS2so.
 - a) Click  to the right of the Base Controller.
 - b) Click **Output Modules**.
 - c) Select XS2so.
5. Add the following inputs, changing name and circuit type as needed.

Input	Qty.	Type	Terminals	Circuit
Two-Hand Control	1	Safety Input	IN9, IN10	Dual-Channel PNP
TOS (ON/OFF)	1	Non-Safety	IN1	Single-Channel 1 Terminal
BOS (ON/OFF)	1	Non-Safety	IN2	Single-Channel 1 Terminal
Manual Reset	1	Non-Safety	IN11	Single-Channel 1 Terminal
Emergency Stop	1	Safety Input	IO1, IN3, IN4	Dual-Channel 3 Terminal

Input	Qty.	Type	Terminals	Circuit
Run (ON/OFF)	1	Non-Safety	IN12	Single-Channel 1 Terminal
Up (ON/OFF)	1	Non-Safety	IN13	Single-Channel 1 Terminal
Down (ON/OFF)	1	Non-Safety	IN14	Single-Channel 1 Terminal
PIP (ON/OFF)	1	Non-Safety	IN5	Single-Channel 1 Terminal
Press Control SQS	1	Safety Input	IN6	Single-Channel 1 Terminal
Foot Switch	1	Safety Input	IO2	Single-Channel 1 Terminal
Press Control Mute Sensor	1	Safety Input	IO3	Single-Channel 1 Terminal
Optical Sensor	1	Safety Input	IN7, IN8	Dual-Channel PNP

6. Go to the **Functional View** tab.
7. Add and configure the Press Control function block.
 - a) Click on any of the empty placeholders in the middle area of the **Functional View** tab. For more information, see [Function Blocks](#) on page 110.
 - b) Select **Function Blocks** and select **Press Control**.
 - c) In the **Press Control Properties** window, select **Mode (Mode Function Block)** and **PCI (Press Control Input Function Block)**. Leave the **Manual Upstroke Setting** box checked.

Figure 72. Press Control Properties

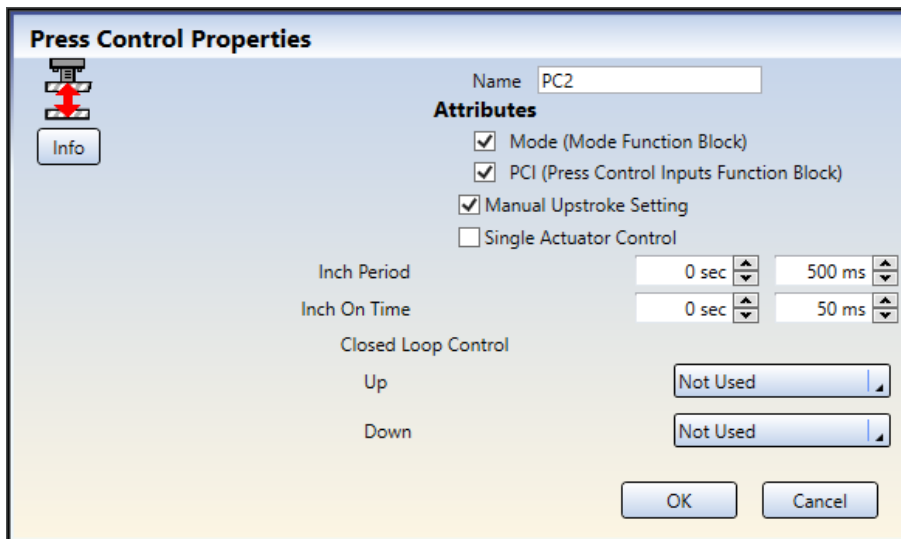

- d) Click **OK**. The **Press Control Inputs Properties** window opens.

Figure 73. Press Control Inputs Properties

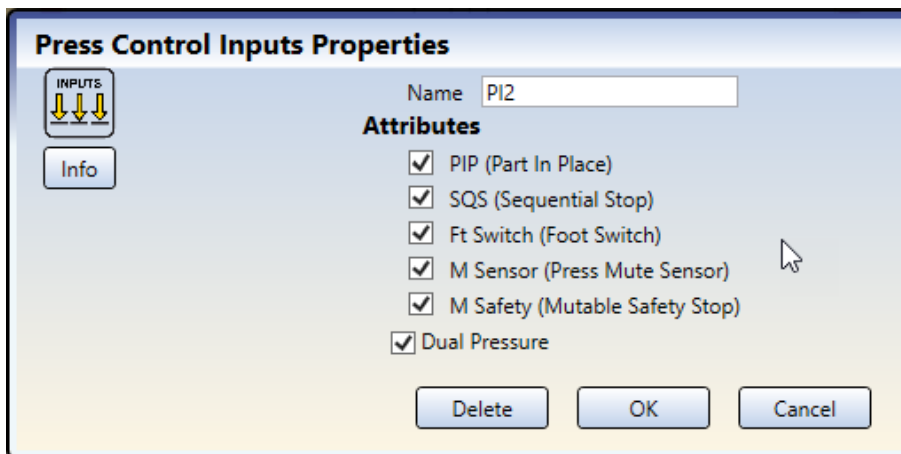

- e) Select all of the check boxes. Note that when **SQS** is selected, three more options display; select them also (all six boxes should be checked).
 - f) Click **OK**.
The **Mode Properties** window displays.
 - g) Click **OK**.
8. Connect the following to the Mode Selection Block:
 - Run input to the Run Input node
 - Up input to the Inch Up input node
 - Down input to the Inch Down input node
 9. Connect the following to the Press Control Inputs Block:
 - Part-In-Place (PIP) input to the PIP input node
 - Sequential Stop (SQS) input to the SQS input node
 - Foot Switch input to the Ft Switch input node
 - Press Control Mute Sensor (PCMS) to the M Sensor input node
 - Optical Sensor to the M Safety input node
 10. Connect the following to the Press Control Block:
 - Two-Hand Control input to the GO input node
 - TOS to the TOS input node
 - BOS to the BOS input node
 - Manual Reset to the RST input node
 - Emergency Stop to the NM Safety input node
 11. Connect the U output node of the Press Control function block to SO1 (change the name of SO1 to "UPSO1").
 12. Connect the D output node of the Press Control function block to SO2 (change the name of SO2 to "DOWNSO2").
 13. Go to page 2 of the Functional View tab (use the arrow in the upper right-hand corner).
 14. Create a reference node for PCx-H and another for PCx-L.
 15. Connect the PCx-H to SO1 (change the name of SO1 to "HIGHSO1").
 16. Connect the PCx-L to SO2 (change the name of SO2 to "LOWSO2").

The sample configuration is complete.



Note: At this point, it can be helpful to reposition the blocks in the **Functional View** for better configuration flow, as shown in the following figure.

Figure 74. Function Block Position

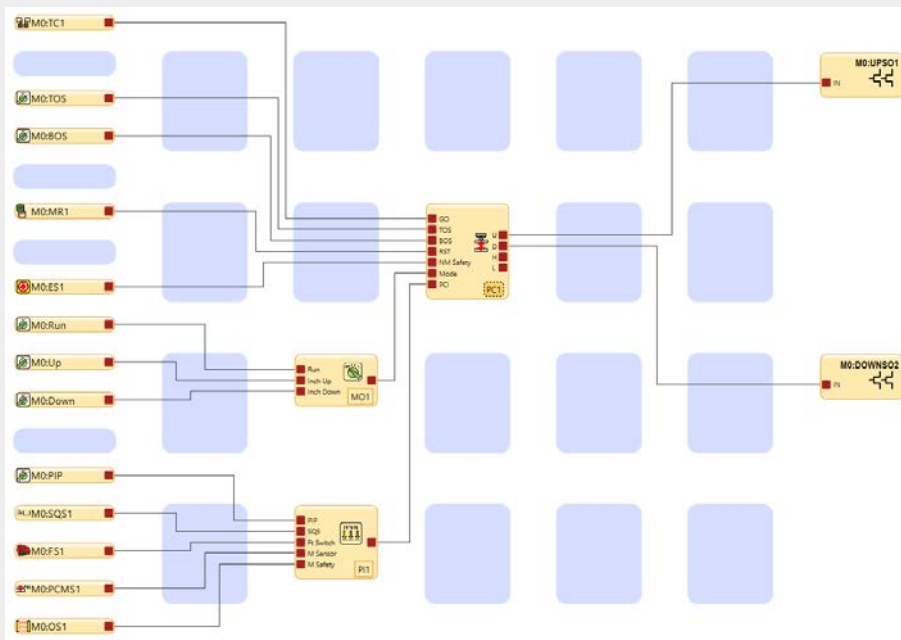

XS/SC26: Simulate the Functionality of the Full Feature Press Control Configuration

The following is how to simulate the functionality of this press control configuration:

1. Click  to enter Simulation Mode.
2. Click **Play** to turn on the simulation timer (similar to powering on the machine).
3. Click the E-stop, optical sensor, TOS, and Run inputs to the On state (green).
4. Click the MR1 reset input.
The Press Control Function block and LOWSO2 output should turn to the On state (green). This is on page 2; click the arrow in the upper right to change pages.
5. Click the PIP input to the On state (green).
6. Click the TC1 input to the On state (green).
The DOWNSO2 output turns On (green).
7. Click the TOS input to the Off state (red).
8. Click the SQS1 and PCMS1 inputs to the On state (green).
The DOWNSO2 output turns Off (red), LOWSO2 output turns Off (red), and the HIGHSO1 (page 2) output turns On (green).
9. Click the TC1 input to the Off state (red).
10. Click the FS1 input to the On state (green).
The DOWNSO2 output turns On (green).
11. Click the BOS input to the On state (green).
The DOWNSO2 and the HIGHSO1 (page 2) output turn Off (red) and the LOWSO2 (page 2) output turns On (green).
12. Click the FS1 input to the Off state (red).
13. Click the TC1 input to the On state (green).
The UPSO1 output turns On (green).
14. Click the BOS, PCMS1, and SQS1 inputs to the Off state (red).
15. Click the TOS input to the On state (green).
The UPSO1 output turns Off (red).
16. Click the TC1 input to the Off state (red).
17. Click the Optical Sensor input to the Off state (red), click the PIP input to the Off state (red) then back to the On state (green), then click the Optical Sensor input back to the On state (green).

The system is ready to start the next cycle by turning the TC1 input to the On state (green) again.

If the TC1 input is turned Off (red) during the down stroke, turning it back On does not change the down stroke; the press continues with the down stroke. To make the press go up (instead of down) after the TC1 input is turned Off, click the MR1 input, then turn the TC1 input back On. If the Optical sensor or E-stop are turned Off during the up or down stroke, the TC1 input should be turned Off, then the MR1 input should be cycled, and then engaging TC1 will turn the UPSO1 output On.

9 Software

The Banner Safety Controller Software is an application with real-time display and diagnostic tools that are used to:

- Design and edit configurations
- Test a configuration in Simulation Mode
- Write a configuration to the Safety Controller
- Read the current configuration from the Safety Controller
- Display real-time information, such as device statuses
- Display fault information

The Software uses icons and circuit symbols to assist in making appropriate input device and property selections. As the various device properties and I/O control relationships are established on the **Functional View** tab, the program automatically builds the corresponding wiring and ladder logic diagrams.

See [Creating a Configuration](#) on page 83 for the configuration design process. See [XS/SC26 Sample Configuration](#) on page 92 for a sample configuration design process.

See [Wiring Diagram Tab](#) on page 111 to connect the devices, and [Ladder Logic Tab](#) on page 113 for the ladder logic rendering of the configuration.

See [Live Mode](#) on page 128 for the Safety Controller Run-time information.

9.1 Abbreviations

Abbreviation ¹⁸	Description
AVM	Adjustable Valve Monitoring input node of the Safety Outputs
AVMx	Adjustable Valve Monitoring input
BP	Bypass input node of the Bypass Blocks and Muting Blocks
BPx	Bypass Switch input
BOS	Bottom of Stroke input node of the Press Control blocks (XS/SC26 only)
CD	Cancel Delay input node of the Safety Outputs, Delay Blocks, and One Shot Blocks
CDx	Cancel Delay input
CSx	Cycle Initiation input
ED	Enabling Device input node of the Enabling Device Blocks
EDx	Enabling Device input
EDM	External Device Monitoring input node of the Safety Outputs
EDMx	External Device Monitoring input
ES	Emergency Stop input node of the Enabling Device Blocks
ESx	Emergency Stop input
ETB	External Terminal Block (SC10-2 only)
FID	Feature identification
FSx	Foot Switch input
FR	Fault Reset input node of the Safety Outputs
Ft Switch	Foot Switch input node of the Press Control Blocks (XS/SC26 only)
GO	Cycle Start input node of the Press Control Blocks (XS/SC26 only)
GSx	Gate Switch input
JOG	Jog Input node of the Enabling Device Blocks
IN	Normal Input node of function blocks and Safety Output blocks
ISD	In-Series Diagnostic
LR	Latch Reset input node of the Latch Reset Block and the Safety Outputs

¹⁸ The "x" suffix denotes the automatically assigned number.

Abbreviation ¹⁸	Description
ME	Mute Enable input node of the Muting Blocks and Two-Hand Control Blocks
MEx	Mute Enable input
MP1	First Muting Sensor Pair input node in Muting Blocks and Two-Hand Control Blocks
MP2	Second Muting Sensor Pair input node (Muting Blocks only)
M Safety	Mutable Safety Input node of the Press Control blocks (XS/SC26 only)
M Sensor	Press Control Mute Sensor input node of the Press Control blocks (XS/SC26 only)
Mx	Base Controller and Expansion modules (in the order displayed on the Equipment tab)
MRx	Manual Reset input
MSPx	Muting Sensor Pair input
NM Safety	Non-Mutable Safety input node of the Press Control blocks (XS/SC26 only)
ONx	On-Off input
OSx	Optical Sensor input
PCMSx	Press Control Mute Sensor input
PIP	Part in Place input node of the Press Control blocks (XS/SC26 only)
PSx	Protective Stop input
RE	Reset Enable input node of the Latch Reset Blocks and the Safety Outputs
ROx	Relay Output
RPI	Requested Packet Interval
RPx	Rope Pull input
RST	Reset node of the SR-Flip-Flop, RS-Flip-Flop, Latch Reset Blocks, Press Control blocks, and Enabling Device Blocks
RUN	Standard operation (RUN) mode input node of the Press Control Mode Blocks (XS/SC26 only)
SET	Set node of the SR- and RS-Flip-Flop Blocks
SMx	Safety Mat input
SOx	Safety Output
SQS	Sequential Stop input node of the Press Control blocks (XS/SC26 only)
SQSx	Press Control SQS (Sequential Stop) input
STATx	Status Output
TC	Two-Hand Control input node of the Two-Hand Control Blocks
TCx	Two-Hand Control input
TOS	Top of Stroke input node of the Press Control blocks (XS/SC26 only)

¹⁸ The "x" suffix denotes the automatically assigned number.







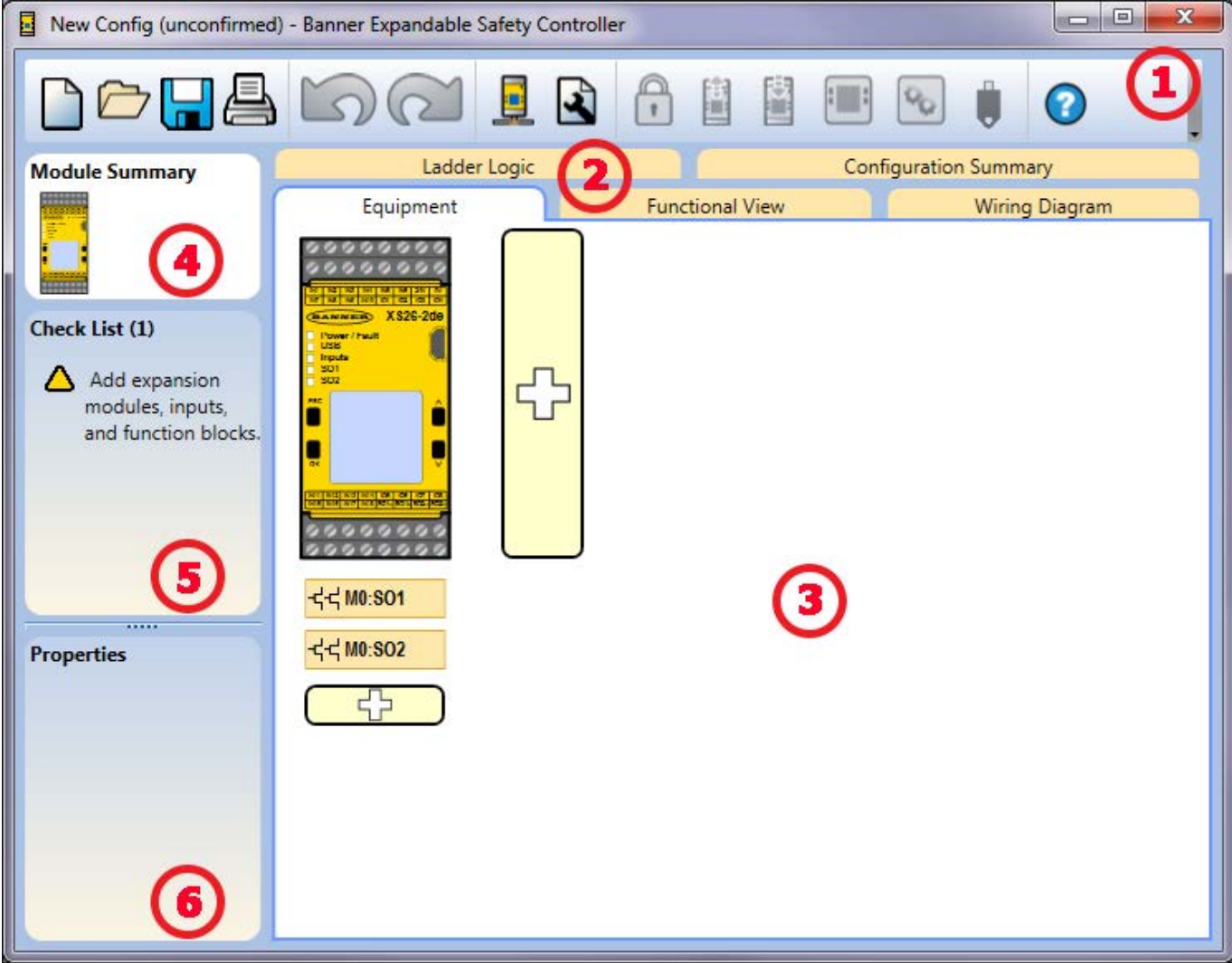







9.2 Software Overview

Note: The following sections use the XS/SC26 as an example. The SC10-2 interface is similar.

Figure 75. Banner Safety Controller Software



(1) Navigation Toolbar

- | | | | |
|---|---|---|--|
|  | Opens an existing project, opens a Recent project, or opens Sample Projects |  | Reads the data, such as Fault Log, Configuration, Network Settings, and Device Information from the Safety Controller |
|  | Saves (or Save As) the project to the user-defined location |  | Writes the data, such as Configuration Settings to the Safety Controller |
|  | Starts a New project |  | Makes the Live Mode view available |
|  | Prints a customizable Configuration Summary |  | Makes the Simulation Mode view available |
|  | Reverts up to ten previous actions |  | Indicates SC-XM2 or SC-XM3 drive connection |
|  | Re-applies up to ten previously reverted actions | | Opens the Help options |
|  | Displays Network Settings and writes the Network Settings to the Safety Controller | | <ul style="list-style-type: none"> • Help—Opens Help topics • About—Displays Software version number and user responsibilities warning • Release Notes—Displays the release notes for each version of the software • Icons—Switches between US- and European-style icons • Support Information—Describes how to request help from the Banner Engineering Advanced Technical Support Group • Language—Selects the Software language options • Software Updates—Shows whether the software is up to date |
|  | Displays Project Settings |  | |
|  | Opens Password Manager | | |

(2) Tabs for Worksheets and Diagrams

Equipment—Displays an editable view of all connected equipment

Functional View—Provides editable iconic representation of the control logic

Wiring Diagram—Displays the I/O device wiring detail for the use by the installer

Ladder Logic—Displays a symbolic representation of the Safety Controller's safeguarding logic for the use by the machine designer or controls engineer

Industrial Ethernet (when enabled)—Displays editable network configuration options

Configuration Summary—Displays a detailed configuration summary

Live Mode (when enabled)—Displays the live mode data, including current faults

Simulation Mode (when enabled)—Displays the simulation mode data

ISD (SC10-2 FID 2 or later and XS26-ISD models)—Displays the ISD chain

(3) Selected View

Displays the view corresponding to the selected tab (**Equipment** view shown)

(4) Module Summary

Displays the Base Controller and any connected modules or displays the SC10-2

(5) Check List

Provides action items to configure the system and correct any errors to successfully complete the configuration

(6) Properties

Displays the properties of the selected device, function block, or connection (properties cannot be edited in this view; click **Edit** below to make changes)

Delete—Deletes the selected item

Edit—Displays the configuration options for the selected device or function block

See [Software: Troubleshooting](#) on page 330 for issues related to the Software functionality.

9.3 New Project

Click **New Project** to select the desired controller and open the **Start a New Project** screen. This screen includes project information that is only available upon initial creation of a project and is not available from the **Project Settings** screen.

XS/SC26

All checkboxes are selected by default. The following options are available:

Has Display

Select this checkbox if your controller has a display. When checked, a "d" displays after the "-2" in the model number shown in the software.

Has Industrial Ethernet

Select this checkbox if your controller has Industrial Ethernet. When checked, an "e" displays after the "-2" in the model number shown in the software.

Is Expandable

Select this checkbox if your controller is a XS26. Clear this checkbox if your controller is a SC26-2.

Has ISD

Select this checkbox if your controller is an XS26-ISDd. Clear this checkbox if your controller is any other model. When checked, the "-2xx" is replaced by "-ISDd" in the model number shown in the software.

SC10-2

Disable Automatic Terminal Optimization Feature (SC10-2 only)

Enable or disable Automatic Terminal Optimization, which allows for the expansion of the number of inputs using an external terminal block (ETB).



Note: The project information listed above is not available from  **Project Settings**, however it is editable from the **Edit** function of the **Module Properties**.

9.4 Project Settings

Figure 76. Project Settings

The screenshot shows a 'Project Settings' dialog box with the following fields and values:

- Configuration Name: New Config
- Project: New Project
- Author: (empty)
- Notes: (empty text area)
- Project Date: 6/2/2014

Buttons: OK, Cancel

Each configuration has an option to include additional project information for easier differentiation between multiple configurations. To enter this information click **Project Settings**.

Configuration Name

Name of the configuration; displayed on the Safety Controller (models with display); different from the file name. The Configuration Name must be between 1 and 16 characters in length.

Project

Project name; useful for distinguishing between various application areas.

Author

Person designing the configuration.

Notes

Supplemental information for this configuration or project.

Project Date

Date pertaining to the project.

9.5 Equipment Tab

Figure 77. Example XS/SC26 **Equipment** Tab

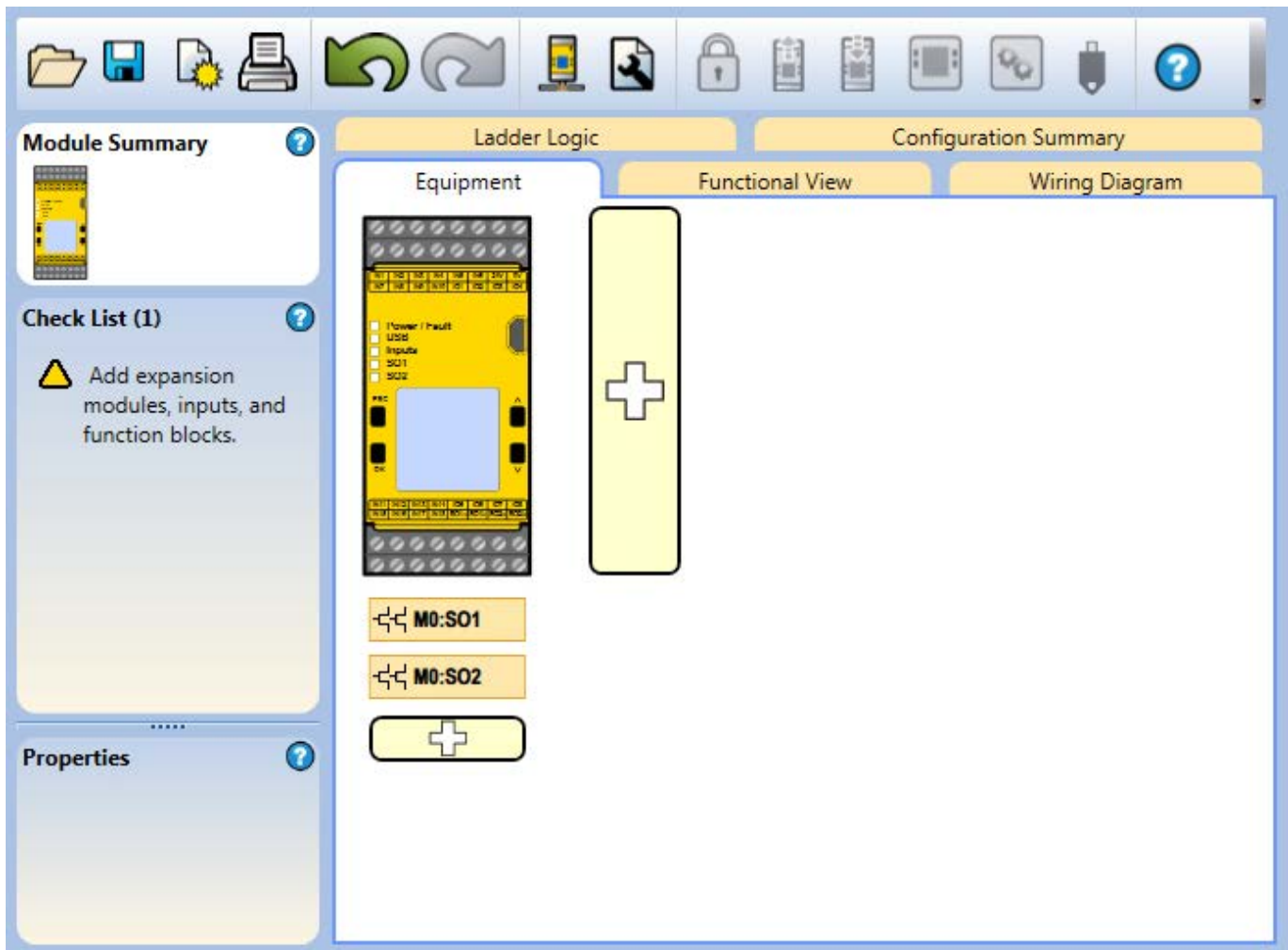

XS/SC26: The **Equipment** tab is used to select the base model, add the expansion modules (input, output, and communication gateway), and add input devices and status outputs. Add the expansion modules by clicking  to the right of the Base Controller module.

Note: If using an EtherCAT module, it must be the first module in the chain, next to the Base Controller.

SC10-2: The **Equipment** tab is used to add input devices and status outputs.

Customize the Base Controller module or SC10-2 by either double-clicking the module or selecting it and clicking **Edit** under the **Properties** table on the left and selecting the appropriate Safety Controller features (display, Ethernet, expandability, ISD, Automatic Terminal Optimization). The properties of Safety and Non-Safety inputs, Status Outputs, Logic Blocks, and Function Blocks are also configured by either double-clicking the block or selecting it and clicking **Edit** under the **Properties** table. Clicking the block the second time de-selects it.

Figure 78. XS/SC26 Module Properties

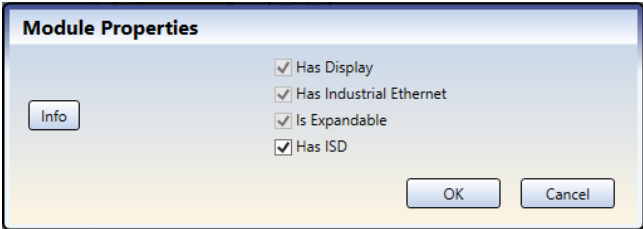
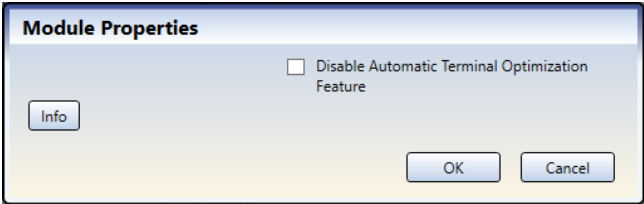
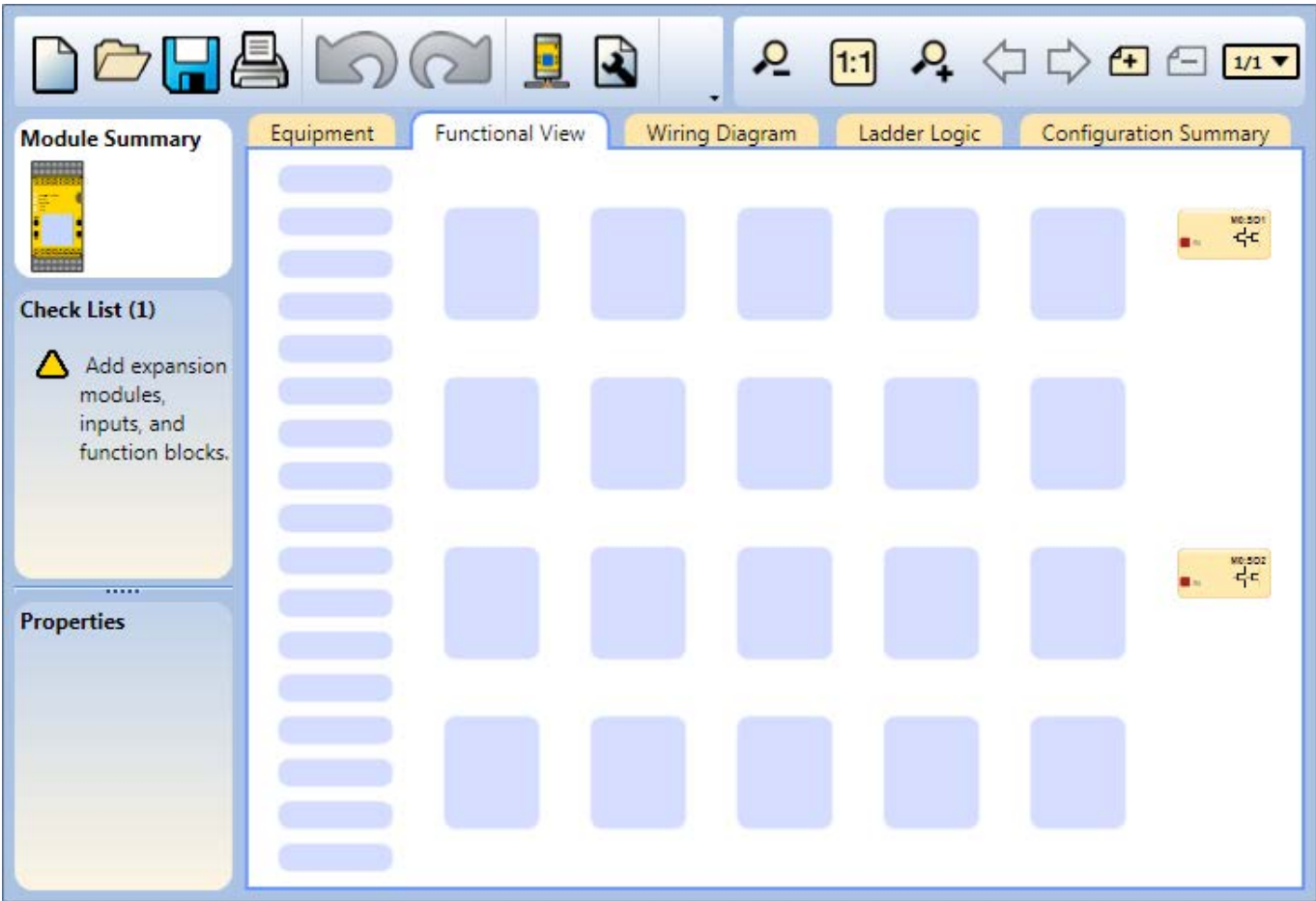

Figure 79. SC10-2 Module Properties



9.6 Functional View Tab

Figure 80. Functional View Tab



The **Functional View** tab is used to create the control logic. The left column of the **Functional View** tab is used for Safety and Non-Safety Inputs; the middle area is used for Logic and Function Blocks and the right column is reserved for Safety Outputs. Safety and Non-Safety Inputs can be moved between the left and middle areas. Function and Logic Blocks can only be moved within the middle area. Outputs are placed statically by the program and cannot be moved. Reference blocks of any type can be placed anywhere within the left and middle areas.



Important: The Banner Safety Controller Software is designed to assist in creating a valid configuration, however, the user is responsible for verifying the integrity, safety, and functionality of the configuration by following the [Commissioning Checkout Procedure](#) on page 299.

On the **Functional View** tab you can:

- Customize the look of the diagram by repositioning inputs, Function blocks, and Logic blocks
- **Undo** and **Redo** up to 10 most recent actions
- Add additional pages for larger configurations using the page navigation toolbar (see [Figure 81](#) on page 108)
- Zoom in and out of the diagram view, or automatically adjust it to the best ratio for the current window size (see [Figure 81](#) on page 108)

Figure 81. Page Navigation and Diagram Size toolbar



- Navigate between pages by clicking the left and right arrows within the page navigation area in the top right corner of the Software
- Modify properties of all blocks by either double-clicking a block or by selecting a block and clicking **Edit** under the **Properties** table
- Delete any block or connection by selecting the item and then either pressing the **Delete** key on your keyboard or clicking **Delete** under the **Properties** table



Note: There is no confirmation of the object deletion. You may undo the deletion by clicking **Undo**.

By default all inputs added on the **Equipment** tab are placed on the **Functional View** tab to the first available placeholder in the left column. There are two ways to move signals from one page to another. To do so, perform one of the following steps:

1. Add a **Reference** to the block located on a different page—click any of the empty placeholders in the middle area, select **Reference** and select the block that is on the next page. Only blocks from other pages can be added as a **Reference**.
2. Re-assign the page—on the page where you want to keep the configuration, move one of the blocks to any of the placeholders in the middle area. Go to the page which contains the block that needs to be moved. Select the block and change the page assignment below the **Properties** table.

Figure 82. Properties Table

Name	Value
Name	Up
Module	M0
Circuit Type	Single-Channel 1 term
Terminals	IN13
Debounce Closed-Op	6 ms
Debounce Open-Clos	50 ms
Output	MO1

Functional View Page 1

Delete Edit

9.6.1 Logic Blocks

Logic Blocks are used to create Boolean (True or False) functional relationships between inputs, outputs, and other logic and function blocks. Logic Blocks accept appropriate safety inputs, non-safety inputs, or safety outputs as an input. The state of the output reflects the Boolean logic result of the combination of the states of its inputs (**1** = On, **0** = Off, **x** = do not care).



CAUTION: Inverted Logic

It is not recommended to use Inverted Logic configurations in safety applications where a hazardous situation can occur.

Signal states can be inverted by the use of NOT, NAND, and NOR logic blocks, or by selecting "Invert Output" or "Invert Input Source" check boxes (where available). On a Logic Block input, inverted logic treats a Stop state (0 or Off) as a "1" (True or On) and causes an output to turn On, assuming all inputs are satisfied. Similarly, the inverted logic causes the inverse function of an output when the block becomes "True" (output turns from On to Off). Because of certain failure modes that would result in loss of signal, such as broken wiring, short to GND/0 V, loss of safeguarding device supply power, etc., inverted logic is not typically used in safety applications. A hazardous situation can occur by the loss of a stop signal on a safety input, resulting in a safety output turning On.

AND



The output value is based on the logical AND of 2 to 5 inputs.
Output is On when all inputs are On.

Input 1	Input 2	Output
0	x	0
x	0	0
1	1	1

OR

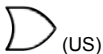

The output value is based on the logical OR of 2 to 5 inputs.
Output is On when at least one input is On.

Input 1	Input 2	Output
0	0	0
1	x	1
x	1	1

There are two types of OR logic blocks: Regular and Reset.

Reset Type OR Block Use so that more than one reset can perform the same reset function (like a hard-wired manual reset and a virtual manual reset) a Reset OR block function has been created. This special type of OR block only accepts reset inputs and can only be connected like a manual reset input in the logic.

Regular Type OR Block Use to perform OR logic on any function that can be connected to an OR block (besides resets) the Regular Logic Type should be selected. Regular is the default setting for the OR logic block.

To select the desired Logic Type (regular or reset), use the **Logic Type** menu in the **Or Properties**.

Figure 83. Or Properties

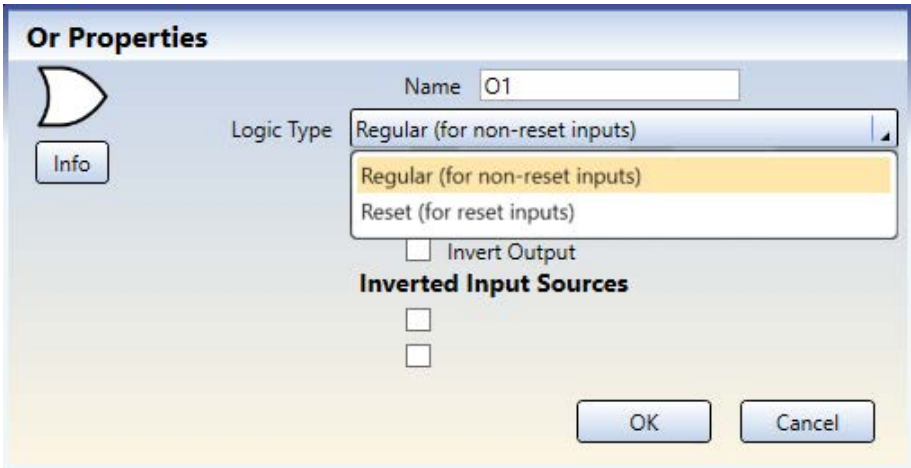

NAND

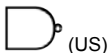

Input 1	Input 2	Output
0	x	1
x	0	1
1	1	0

The output value is based on inverting the logical AND of 2 to 5 inputs.

Output is Off when all inputs are On.

NOR

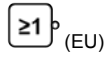
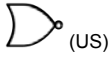

The output value is based on inverting the logical OR of 2 to 5 inputs.

Output is On when all inputs are Off.

Input 1	Input 2	Output
0	0	1
1	x	0
x	1	0

XOR



The output value is an exclusive OR of 2 to 5 inputs.

Output is On when only one (exclusive) input is On.

Input 1	Input 2	Output
0	0	0
0	1	1
1	0	1
1	1	0

NOT

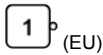
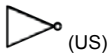

Output is the opposite of the input.

Input	Output
0	1
1	0

RS Flip-Flop



This block is Reset Dominant (Reset has priority if both inputs are On).

Input 1 (Set)	Input 2 (Reset)	Output
0	0	Value remains the same
0	1	0 (Reset)
1	0	1 (Set)
1	1	0 (Reset has priority)

SR Flip-Flop



This block is Set Dominant (Set has priority if both inputs are On).

Input 1 (Set)	Input 2 (Reset)	Output
0	0	Value remains the same
0	1	0 (Reset)
1	0	1 (Set)
1	1	1 (Set has priority)

9.6.2 Function Blocks

Function blocks provide built-in functionality for most common applications in one block. Although it is possible to design a configuration without any function blocks, using the function blocks offers substantial efficiency, ease of use, and improved functionality.

Most function blocks expect the corresponding safety input device to be connected to it. The checklist on the left creates a notification if any required connections are missing. Depending on the application, some function blocks may be connected to other function blocks and/or logic blocks.

Dual-channel safety input devices have two separate signal lines. Dual-channel signals for some devices are both positive (+24 V DC) when the device is in the Run state. Other devices may have a complementary circuit structure where one channel is at 24 V DC and the other is at 0 V DC when the device is in the Run state. This manual uses the Run state/Stop state convention instead of referring to a safety input device as being ON (24 V DC) or OFF (0 V DC).

9.7 Wiring Diagram Tab

Figure 84. Wiring Diagram Tab—XS26

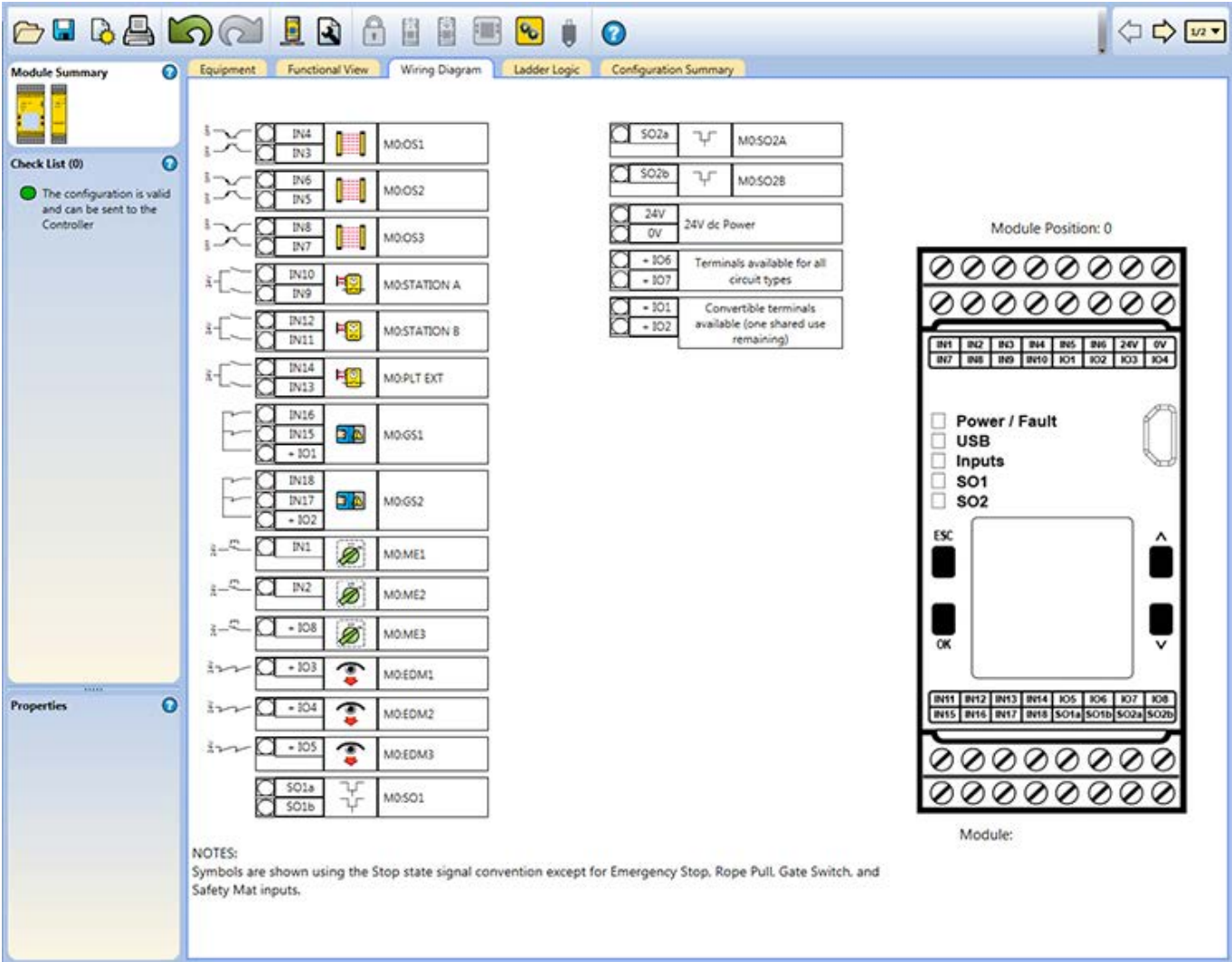

The **Wiring Diagram** tab shows the terminal assignments and the electrical circuits for the safety and non-safety inputs, Safety Outputs, and status outputs, and any terminals that are still available for the selected module. Use the wiring diagram as a guide to physically connect the devices. Navigate between modules using the Page Navigation toolbar at the top right corner of the Software.

Figure 85. *Wiring Diagram Tab—SC10-2 with External Terminal Blocks*

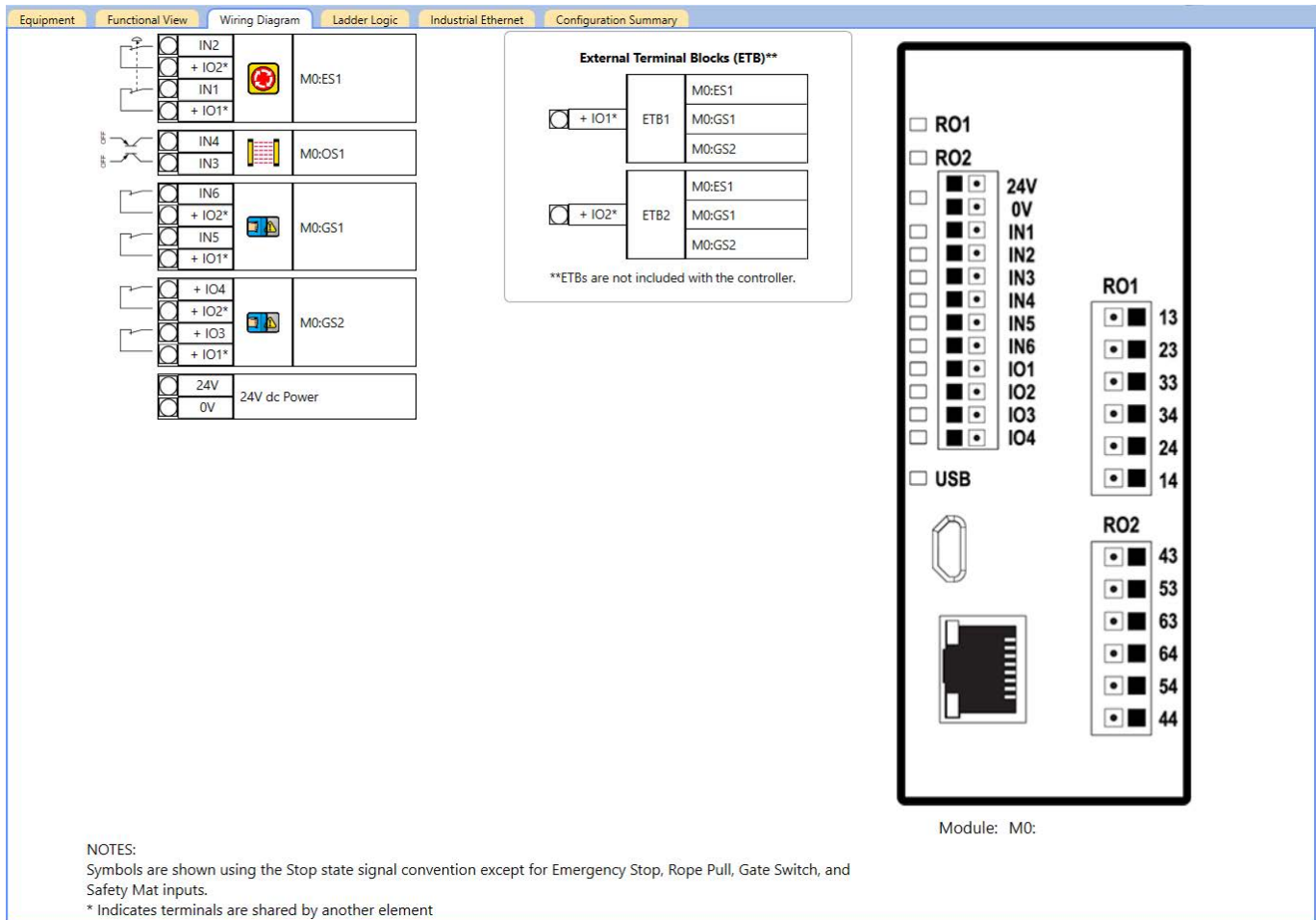

9.8 Ladder Logic Tab

Figure 86. Ladder Logic Tab

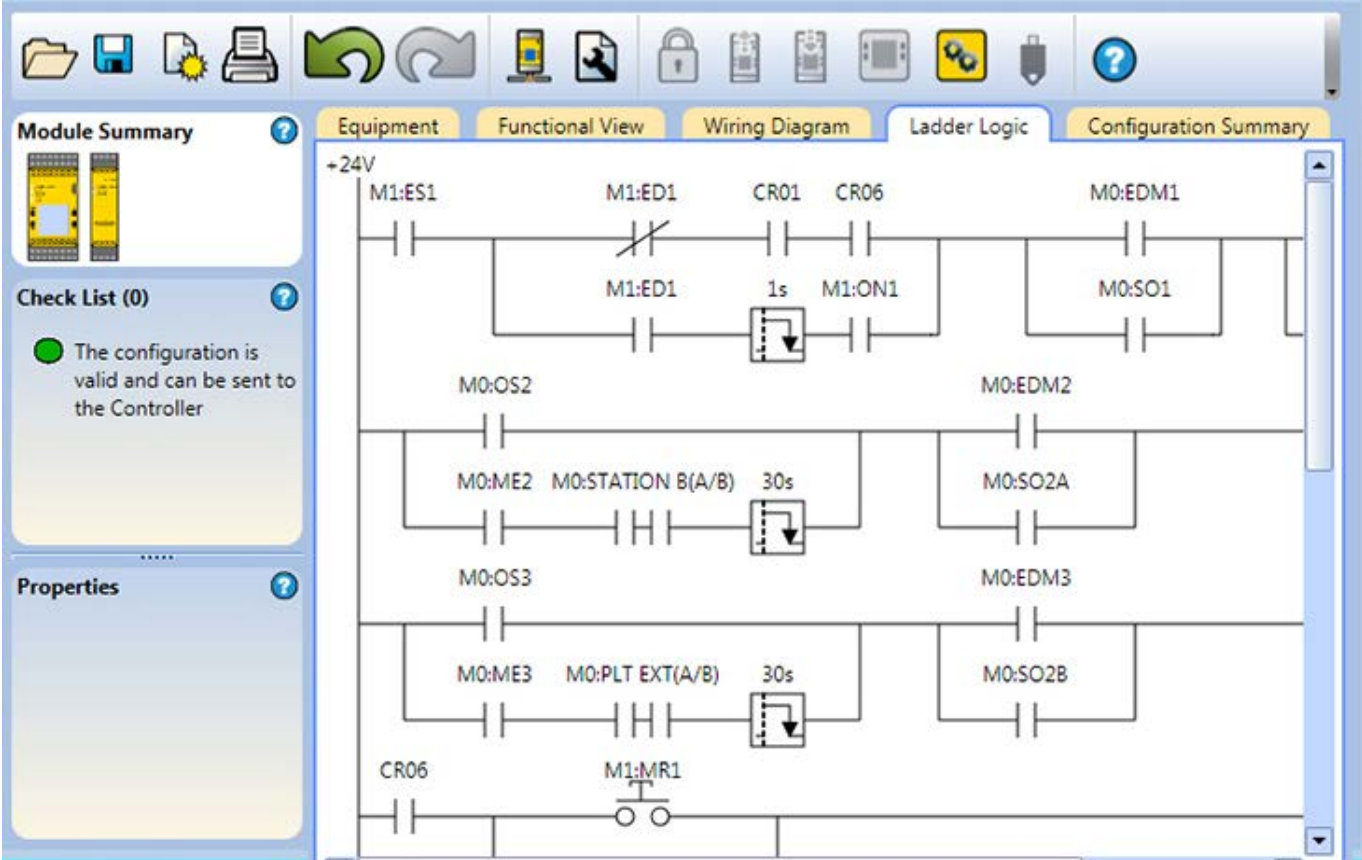

The **Ladder Logic** tab displays a simplified relay logic rendering of the configuration.

9.9 ISD Tab

Figure 87. SC10-2 ISD Tab

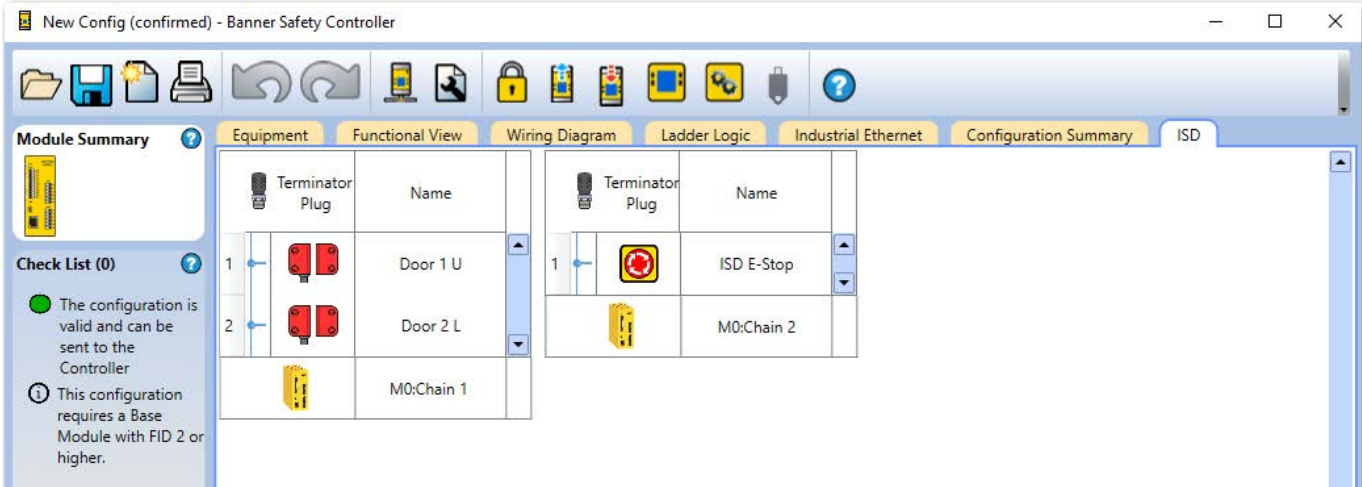
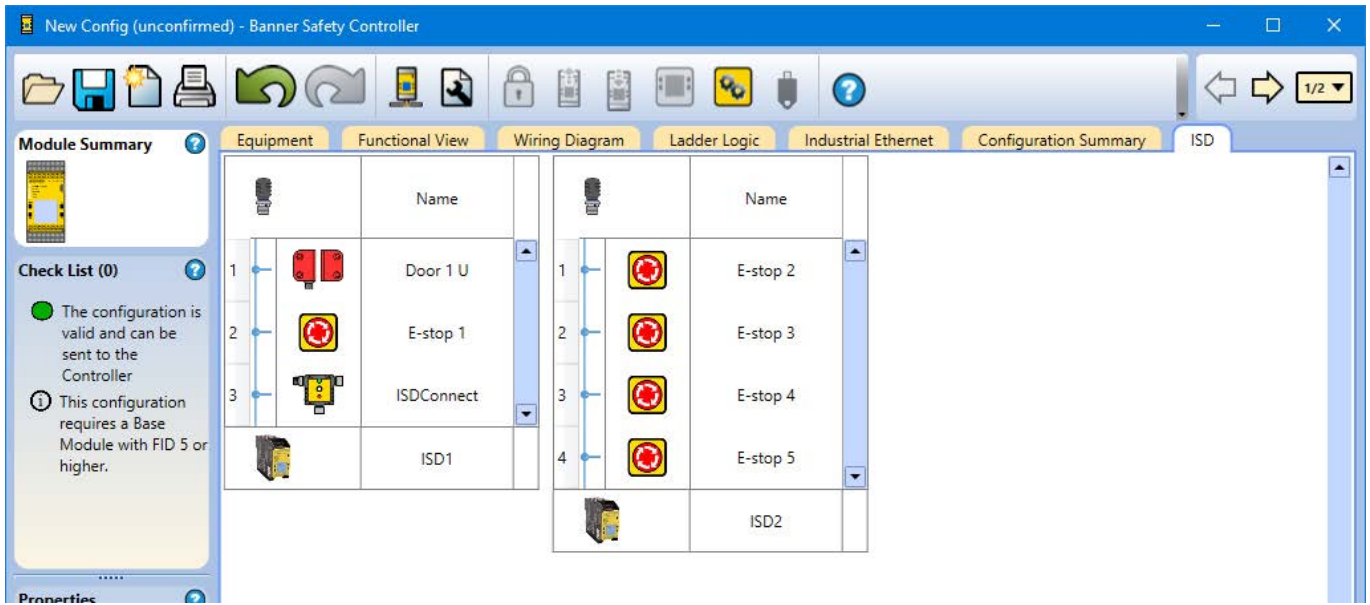

Figure 88. XS26-ISD ISD Tab



The **ISD** tab shows the order and device names of the connected ISD devices in each ISD chain.

For XS26-ISD models with more than two chains, use the arrows in the upper right to see the additional chains.

In Live Mode, the **ISD** tab displays real-time information (updated approximately once per second) about the connected devices. In the following example, a gate switch is open, as shown by the red indicator, or Off status, and the blank indicator under Actuator.



Note: There is a data startup delay of approximately 10 seconds.

Figure 89. ISD Tab in Live Mode with a Switch Open

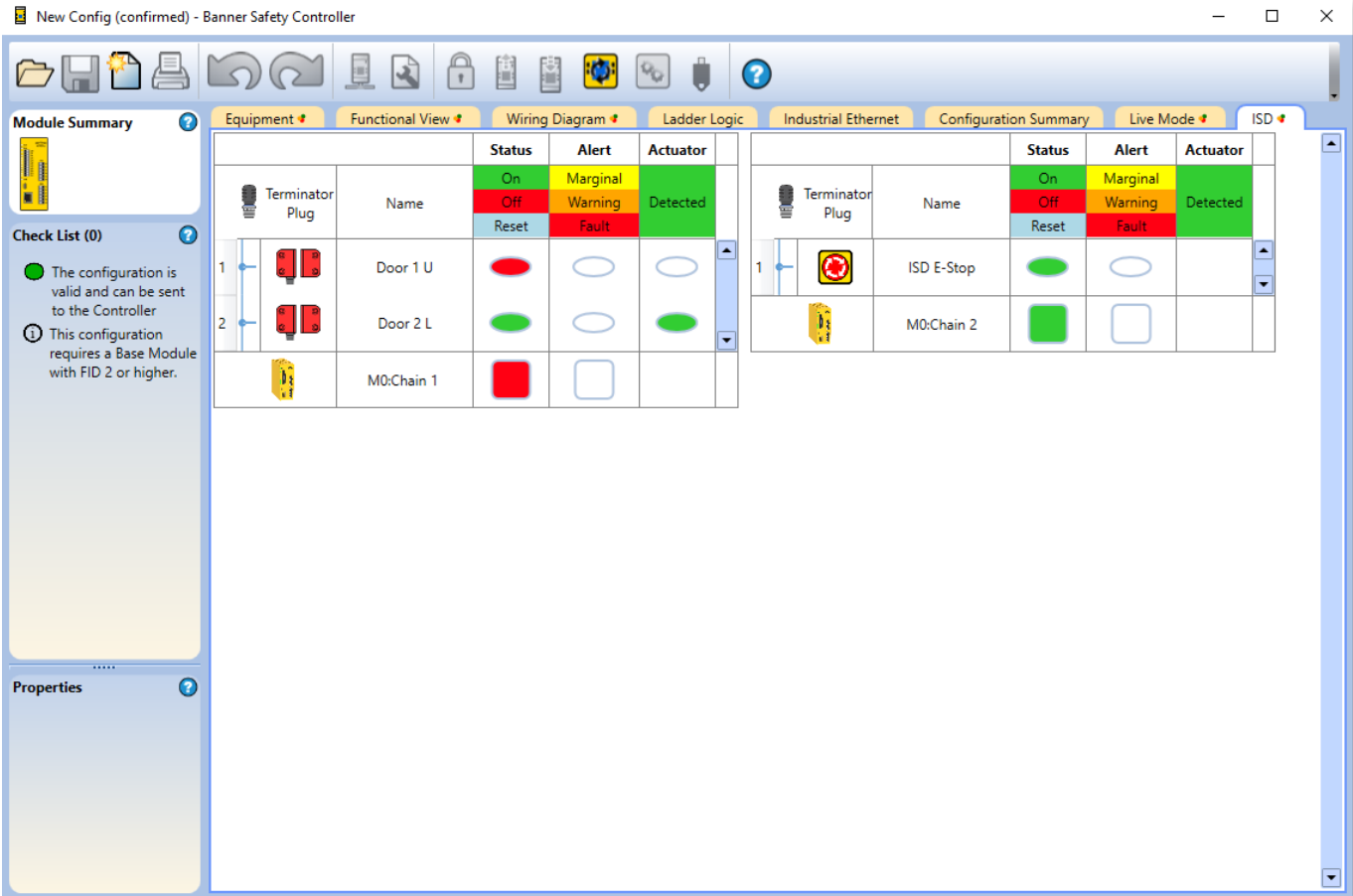

When the ISD devices are manually entered, device #1 is positioned closest to the terminating plug on the **ISD** tab. The device numbers increase the closer they are to the controller.

When **AutoDetect ISD** is selected, device #1 is positioned closest to the controller on the **ISD** tab. The numbers increase the further they are away from the controller, toward the terminating plug. This is based on the assumption that most changes in chain length will occur at the terminating plug end of the chain.

In Live Mode, click on a device to view diagnostic data about that device. The data includes output, input, and whether the actuator is detected.

Figure 90. ISD Tab in Live Mode with Diagnostic Data

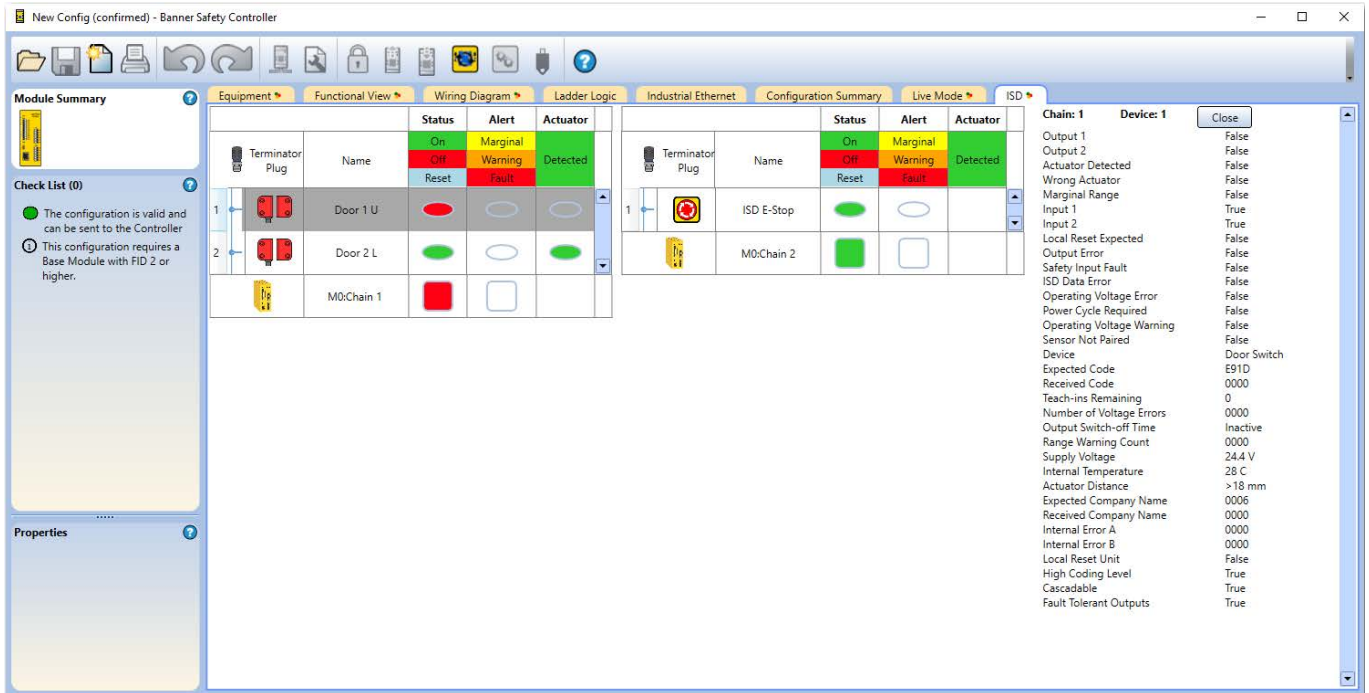

In Live Mode, click on a chain name to view diagnostic data about the chain.

Figure 91. ISD Tab in Live Mode with Chain Data

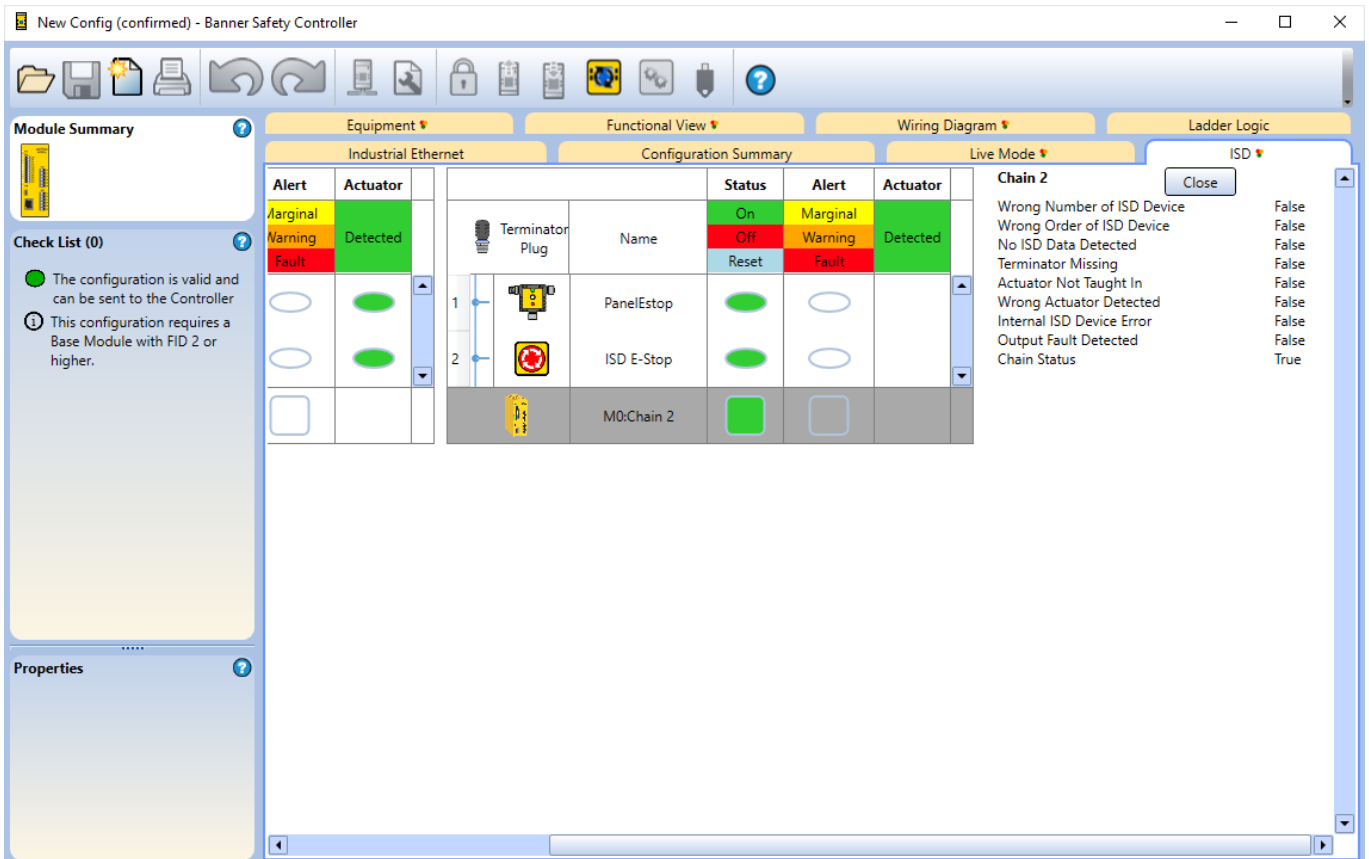

9.10 Industrial Ethernet Tab

Figure 92. XS/SC26 Industrial Ethernet Tab—Virtual Status Outputs

The screenshot shows the 'Virtual Status Outputs' configuration window in the software. The window title is 'Industrial Ethernet' and it contains a 'Configuration Summary' tab. A dropdown menu is open for 'Modbus/TCP', listing options like 'EtherNet/IP Assemblies', 'EtherNet/IP Explicit Msgs', 'PCCC', 'PROFINET', and 'EtherCAT'. The main area displays a table titled 'Map for the Virtual Status Outputs' with columns for 'VO Status', 'Function', 'Discrete', '3X/4X Reg:Bit', 'Fault Flag', '3X/4X (UINT)', 'Fault Index', and 'VO Status'. The table lists seven virtual outputs (VO1-VO7) with their respective functions and register/bit addresses.

VO Status	Function	FID1 or FID2 Controller						
		VO Status	Fault Flag	Fault Index	VO Status	Fault Index	VO Status	
VO1	System Lockout	10001	1:0	10065	5:0	41	11001	9
VO2	Track Any Input Fault	10002	1:1				11002	9
VO3	Track Output Fault All	10003	1:2				11003	9
VO4	Track input group 1 - M0:ES1	10004	1:3				11004	9
VO5	Track input group 2 - M0:ES1	10005	1:4				11005	9
VO6	Track input group 3 - M0:ES1	10006	1:5				11006	9
VO7	+	10007	1:6				11007	9

NOTE: Refer to the Instruction Manual for column and row heading descriptions

Figure 93. SC10-2 Industrial Ethernet Tab—Virtual Status Outputs

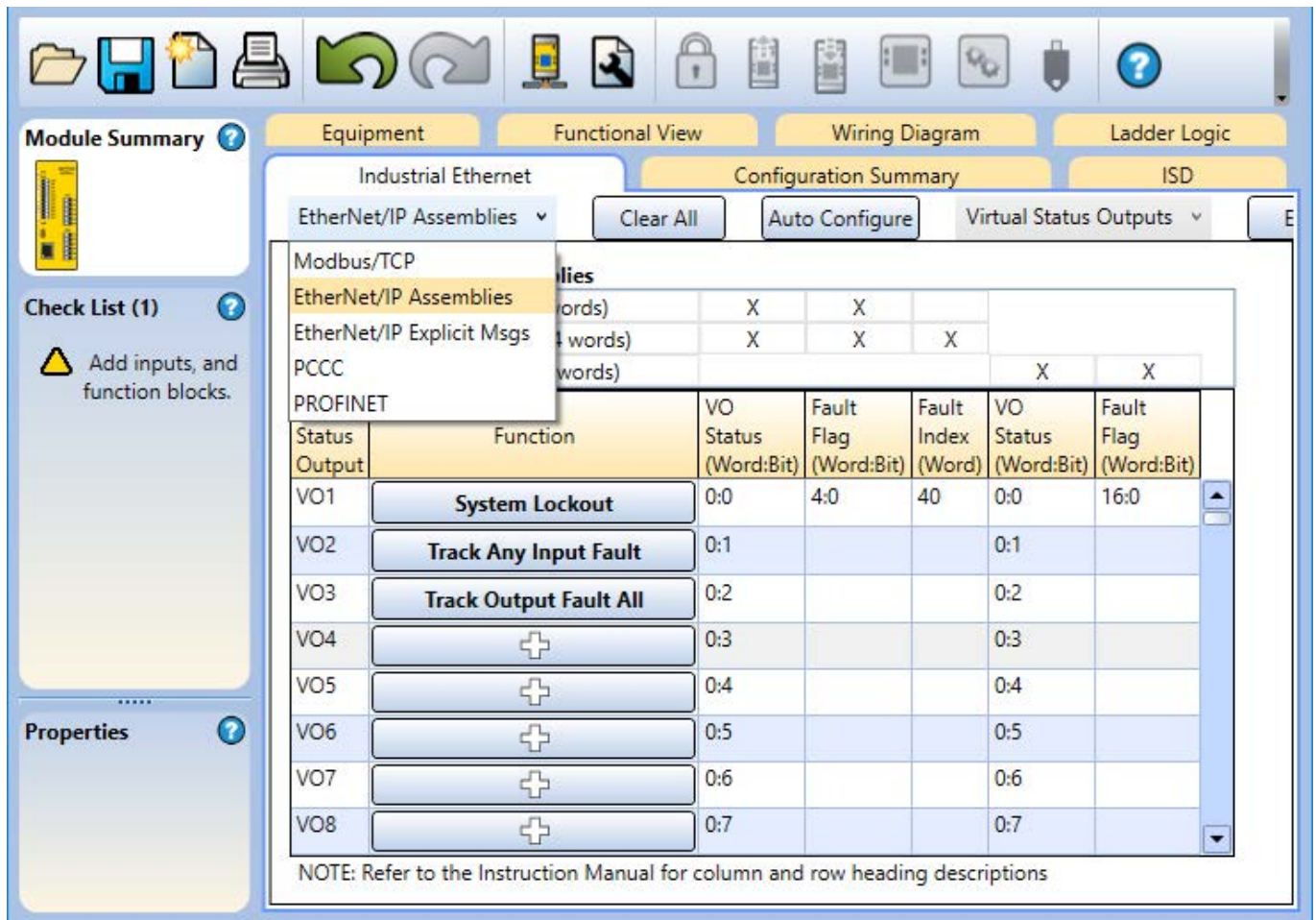

The **Industrial Ethernet** tab allows configuration of the Virtual Status Outputs, which offer the same functionality as **Status Outputs** (added on the **Equipment** tab) over the network (see [Status Output Signal Conventions](#) on page 78 and [Status Output Functionality](#) on page 79 for detailed information). Up to 64 Virtual Status Outputs can be added for any configuration using Modbus TCP, EtherNet/IP Input Assemblies, EtherNet/IP Explicit Messages, and PCCC protocols on FID 1 XS/SC26 Safety Controllers and up to 256 Virtual Status Outputs can be added on FID 2 or later XS/SC26 Safety Controllers and SC10-2 Safety Controllers. FID 2 or later Base Controllers and SC10-2 Safety Controllers can also use PROFINET. FID 6 or later expandable, Ethernet-enabled XS26 Base Controllers can also use EtherCAT when the XSeCAT Communications Gateway is added.

To access the **Industrial Ethernet** tab:

1. Click **Network Settings**.
2. Select **Enable Network Interface**.
3. On the **Industrial Ethernet** tab, use the dropdown list to select the desired protocol.
4. Adjust any settings, if necessary. See
 - [Network Settings: Modbus TCP, Ethernet/IP, PCCC](#) on page 120
 - [Network Settings: PROFINET](#) on page 121
 - [Network Settings: EtherCAT](#) on page 121
5. Click **OK**.

Use the **Auto Configure** function, located on the **Industrial Ethernet** tab, to automatically configure the Virtual Status

Outputs to a set of commonly used functions, based on the current configuration. Click **+** in the **Function** column next to any of the **VOx** cells to add a Virtual Status Output manually. Functions of all Virtual Status Outputs can be modified by clicking on the button that contains the name of the function of the Virtual Status Output or by clicking **Edit** under the **Properties** table when VOx is selected.

To view information about virtual non-safety inputs, select **Virtual Non-Safety Inputs** from the dropdown menu in the upper right.

Figure 94. Industrial Ethernet Tab—Virtual Non-Safety Inputs

Virtual On-Off and Mute Enable

Virtual Input	Name	Control	
		Coil	4x Reg.Bit

Virtual Manual Reset and Cancel Off Delay

Virtual Input	Name	Control		Feedback	
		Coil	4x Reg.Bit	Discrete	3x/4x Reg.Bit
Actuation Code			19		22
VRCD1	VMR1	4001	17:0	15001	20:0

9.10.1 Network Settings



Network Settings: Modbus TCP, Ethernet/IP, PCCC

Figure 95. Network Settings

Click **Network Settings** to open the **Network Settings** window. In the case of a Modbus TCP connection, the default TCP port used is 502, by specification. This value is not shown in the **Network Settings** window.

Table 7: Default Network Settings

Setting Name	Factory Default Value
IP Address	192.168.0.128
Subnet Mask	255.255.255.0
Gateway Address	0.0.0.0
Link Speed and Duplex Mode	Auto Negotiate

Set the IP Address directly via the Network Settings window by entering the desired information as noted in [Table 7](#) on page 120. The **Use onboard interface to set the last octet and actuation code** checkbox allows you to set the basic IP address information but finalize the last octet (and actuation code if required) when the unit is installed. See [ClickSet IP Process](#) on page 167.

An **Actuation Code** is required for configurations containing a virtual manual reset or cancel delay input. The virtual manual reset or cancel delay input must be added to enable the **Actuation Code** field.

The **Advanced** option allows further configuration of Modbus TCP and EtherNet/IP settings, such as Swap character bytes, MSW and LSW sending precedence, and String Length Type (EtherNet/IP and PCCC).

Click **Send** to write the network settings to the Safety Controller. Network settings are sent separately from the configuration settings. For SC26-2 and XS/SC26 FID 3 and later units, the network settings are automatically sent only if the Safety Controller is a factory default Safety Controller.

Click **Network Timeout Enabled** to have any configured Virtual On/Off or Virtual Mute Enable become inactive in the event of a network timeout condition. The network timeout time is fixed at 5 seconds.



Note: Use **Password Manager** to enable or disable the ability for User2 and User3 to change the network settings.



Network Settings: PROFINET

After selecting the PROFINET protocol on the **Industrial Ethernet** tab, click  **Network Settings** to open the **Network Settings** window. PROFINET is available on XS/SC26 FID 2 or later and SC10-2.

Figure 96. Network Settings—PROFINET



Click **Send** to write the network settings to the Safety Controller. Network settings are sent separately from the configuration settings. For SC10-2 and XS/SC26 FID 3 and later units, the network settings are automatically sent only if the Safety Controller is a factory default Safety Controller.

Click **Network Timeout Enabled** to have all configured Virtual On/Off or Virtual Mute Enable become inactive in the event of a network timeout condition. The network timeout time is fixed at 5 seconds.

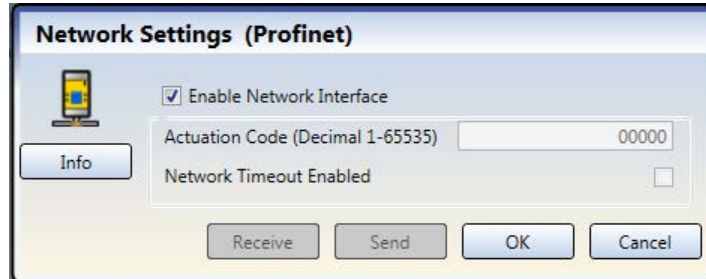

Note: Use **Password Manager** to enable or disable the ability for User2 and User3 to change the network settings.



Network Settings: EtherCAT

After adding the XSeCAT Communication Gateway, the EtherCAT protocol on the **Industrial Ethernet** tab is the protocol under **Network Settings**. Click  **Network Settings** to open the **Network Settings** window. EtherCAT is available on XS26 FID 6 or later base controllers with an XSeCAT communication gateway added.

Figure 97. Network Settings—EtherCAT



Click **Send** to write the network settings to the Safety Controller. Network settings are sent separately from the configuration settings. The network settings are automatically sent only if the Safety Controller is a factory default Safety Controller.

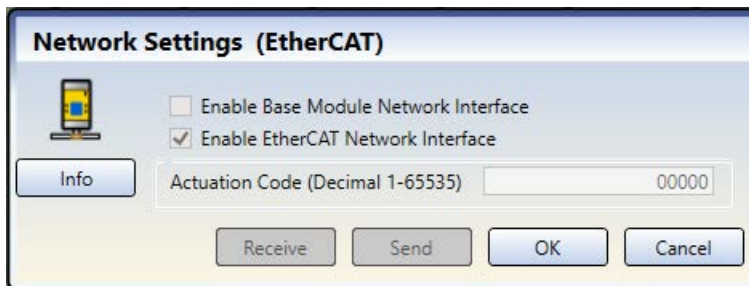

Note: Click **Receive** to download the settings from the connected Safety Controller.



Note: Use **Password Manager** to enable or disable the ability for User2 and User3 to change the network settings.

9.10.2 PLC Tags/Labels File Creation

Use the Banner Safety Controller Software to generate a .L5X, .csv, or .xml file that contains the names of all the virtual status outputs and inputs.

To use the names created in the Banner Safety Controller software as the PLC Tags/Labels, import the .L5X, .csv, or .xml file into the PLC software for PLCs using Ethernet/IP Assemblies, PROFINET, or EtherCAT.

First, create all of the status outputs and inputs that are desired in the Banner Safety Controller Software. Assign an actuation code under **Network Settings**, if needed. Then, make sure that the desired protocol is selected (either Ethernet/IP Assemblies, PROFINET, or EtherCAT).

L5X File

The .L5X file is an XML (eXtensible Markup Language) file that stores both EtherNet/IP connection details and tag descriptions. Exporting this file from the Safety Controller software and importing it into the RS Studio 5000 PLC software is a convenient way to make an EtherNet/IP connection between the PLC and the Safety Controller with labeled tag descriptions, all in one step.

CSV File

To use the exported CSV file to label the tag descriptions in the PLC program, first use the EDS file to create the EtherNet/IP connection between the PLC and the Safety Controller. Select the same connection for the EDS file connection (for example, Eight ISD Chains) and in the **Export to CSV & L5X** window. This ensures that the labels from the exported CSV will match the tags created by the EDS file.

See:

- [Create L5X Files For Ethernet/IP Assemblies](#) on page 170
- [Banner Safety Controller EDS File Installation in ControlLogix Software](#) on page 175
- [Create a XML File For PROFINET](#) on page 260
- [Create a PLCopenXML for EtherCAT for TwinCAT 3.0](#) on page 287

9.10.3 EtherNet/IP Assembly Objects



Note: The EDS file is available for download at www.bannerengineering.com. For additional information, see [Industrial Ethernet Overview](#) on page 166.

Input (T>O) Assembly Objects

Instance ID	Data Length (16-bit words)	Description
100 (0×64)	8	Used to access the basic information about the Virtual Status Outputs 1–64.
101 (0×65)	104	Used to access the advanced information (including the basic information) about the Virtual Status Outputs.
102 (0×66)	150	Used to access the fault log information and provides no Virtual Status Output information.
103 (0×67)	35	Used to access the basic information about Virtual Status Outputs 1–256 and feedback information about Virtual Reset and Virtual Cancel Delay inputs. Available on FID 2 or later Base Controllers and SC10-2.
104 (0×68)	112	Used to access the basic information about Virtual Status Outputs 1–256, feedback information about Virtual Reset and Virtual Cancel Delay inputs, and to support communications with ISD-enabled devices with one or two chains.
105 (0×69)	240	Used to access the basic information about Virtual Status Outputs 1–256, feedback information about Virtual Reset and Virtual Cancel Delay inputs, and to support communication with ISD-enabled devices with more than two chains.

Output (O>T) Assembly Object

Instance ID	Data Length (16-bit words)	Description
112 (0×70)	2	<i>Reserved</i>
113 (0×71)	11	Used to control Virtual Inputs (On/Off, Mute Enable, Reset, Cancel Delay). Available on FID 2 or later Base Controllers and SC10-2.
114 (0×72)	14	Used to control Virtual Inputs (On/Off, Mute Enable, Reset, Cancel Delay) and to support communications with ISD-enabled devices.

Configuration Assembly Object

The Configuration Assembly Object is not implemented. However, some EtherNet/IP clients require one. If this is the case, use Instance ID 128 (0x80) with a data length of 0.

Set the Data Type of the communication format to INT.
Set the RPI (requested packet interval) to a minimum of 150.

9.11 Configuration Summary Tab

Figure 98. Configuration Summary Tab

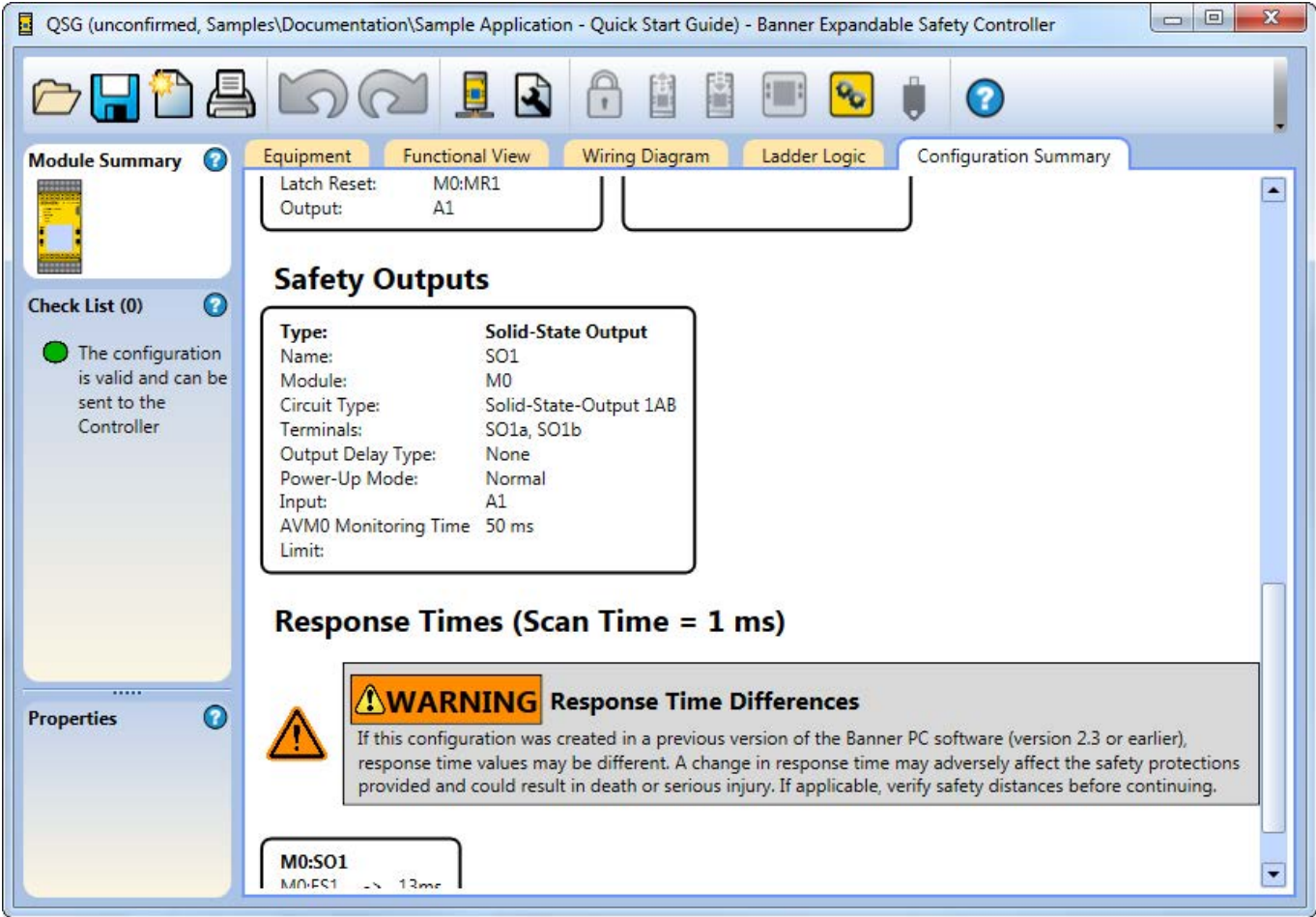

The **Configuration Summary** tab displays the detailed information about all configured inputs, Function and Logic Blocks, Safety Outputs, Status Outputs, and the related Response Times in a text format.

9.12 Print Options

Figure 99. Print Options

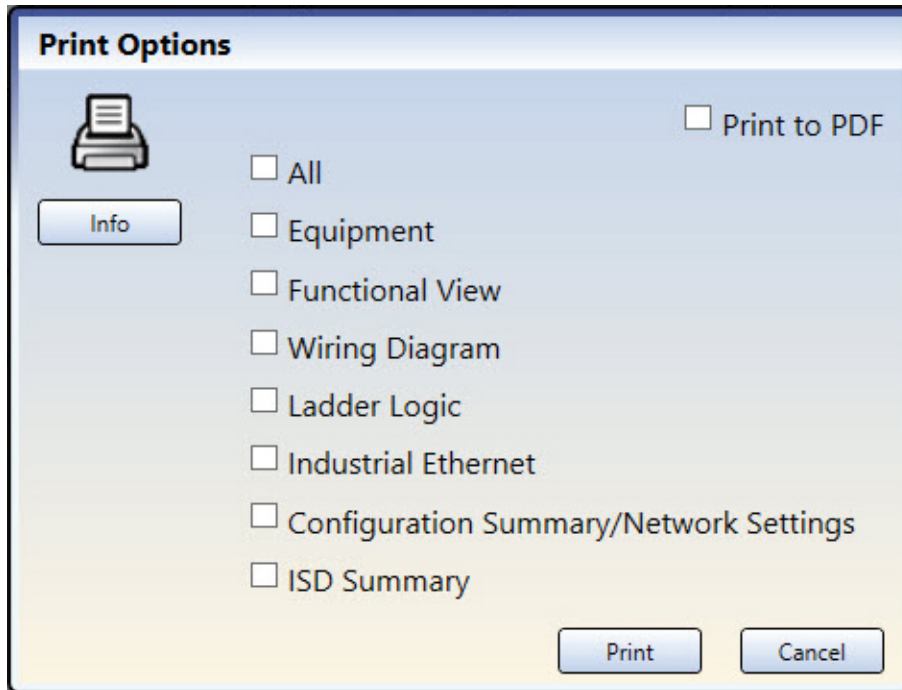

The Software provides several options to print the configuration. Click **Print** on the toolbar to access the **Print Options** window.

The following print choices are available:

- **All**—Prints all views, including **Network Settings** (in Ethernet-enabled versions)
- **Equipment**—Prints the **Equipment** tab
- **Functional View**—Prints the **Functional View** tab
- **Wiring Diagram**—Prints the **Wiring Diagram** tab
- **Ladder Logic**—Prints the **Ladder Logic** tab
- **Industrial Ethernet**—Prints the **Industrial Ethernet** tab
- **Configuration Summary/Network Settings**—Prints the **Configuration Summary** and **Network Settings** (when available)
- **ISD Summary**—Prints the **ISD** tab (available on SC10-2 FID 2 or later devices and XS26-ISD FID 5 or later devices)

Printing Options:

- **Print to PDF**—Prints the selection to a PDF file stored in a user-defined location
- **Print**—Opens the default Windows Print dialog and sends the selection to the user-defined printer

9.13 XS/SC26 Password Manager

Password Manager is available when a Safety Controller is connected to the PC via USB. The information shown in **Password Manager** comes from the Safety Controller.

Figure 100. XS/SC26 Password Manager (version 4.2 shown)

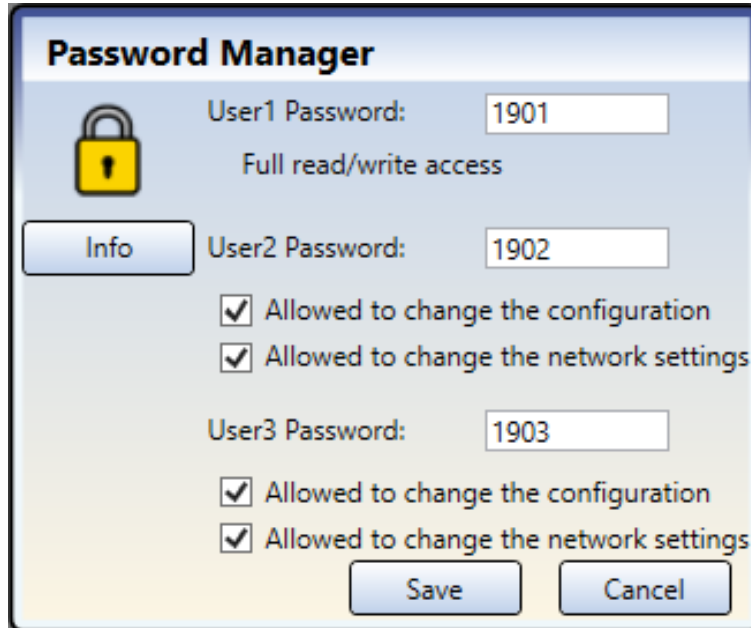

Click  **Password Manager** on the Software toolbar to edit the configuration access rights. The Safety Controller stores up to three user passwords to manage different levels of access to the configuration settings. The password for User1 provides full read/write access and the ability to set access levels for User2 and User3 (user names cannot be changed). Basic information, such as network settings, wiring diagrams, and diagnostic information, is accessible without a password. A configuration stored on a PC or an SC-XM2/3 drive is not password-protected.

User2 or User3 can write the configuration to the Safety Controller when **Allowed to change the configuration** is enabled. They can change the network settings when **Allowed to change the network settings** is enabled. For Software version 4.1 or earlier, the **Allowed to view the configuration** option for User2 and User3 is available and can be enabled when **Require password to view configuration** for User1 is checked. Their respective passwords will be required.

Click **Save** to write the password information to the Safety Controller.

Only User1 can reset the XS/SC26 back to the factory defaults.





Note: The default passwords for User1, User2, and User3, are 1901, 1902, and 1903, respectively. It is highly recommended to change the default passwords to new values.

9.14 SC10-2 Password Manager

Password Manager is available when a Safety Controller is connected to the PC via USB. The information shown in **Password Manager** comes from the Safety Controller.

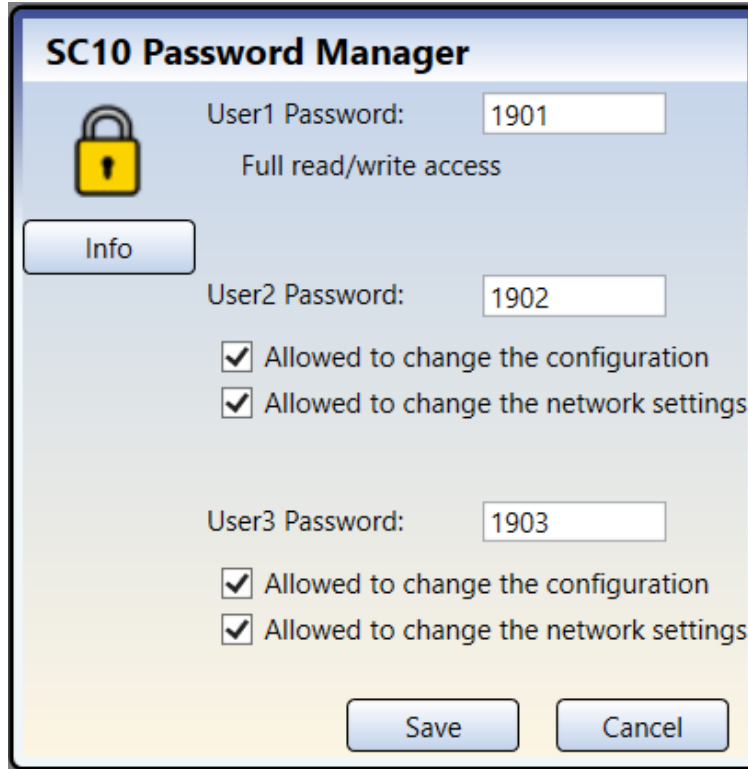
Figure 101. SC10-2 Password Manager



Click  **Password Manager** on the Software toolbar to edit the configuration access rights. The Safety Controller stores up to three user passwords to manage different levels of access to the configuration settings. The password for User1 provides full read/write access and the ability to set access levels for User2 and User3 (user names cannot be changed). The configuration, network settings, wiring diagrams, and diagnostic information are accessible without a password. A configuration stored on a PC or an SC-XM2/3 drive is not password-protected.

User2 or User3 can write the configuration to the Safety Controller when **Allowed to change the configuration** is enabled. They can change the network settings when **Allowed to change the network settings** is enabled. Their respective passwords will be required.

Click **Save** to apply the password information to the current configuration in the Software and to write the password information to the Safety Controller.



Note: The default passwords for User1, User2, and User3, are 1901, 1902, and 1903, respectively. It is highly recommended to change the default passwords to new values.

Only User1 can reset the SC10-2 back to the factory defaults.

9.15 Viewing and Importing Controller Data

The Banner Safety Controller Software allows viewing or copying current Safety Controller data, such as model number and firmware version, configuration and network settings, and the wiring diagram.



Read from Controller is available when a Safety Controller is connected to the PC via USB.

Viewing System and Network Settings Snapshot

Click  **Read from Controller** on the Software toolbar. The current Safety Controller settings are displayed:

- Configuration Name
- Configuration CRC
- Date Confirmed
- Time confirmed
- Author
- Project Name
- IP Address
- Subnet mask
- Gateway address
- Link speed and duplex mode
- MAC ID

Figure 102. Viewing System and Network Settings Snapshot

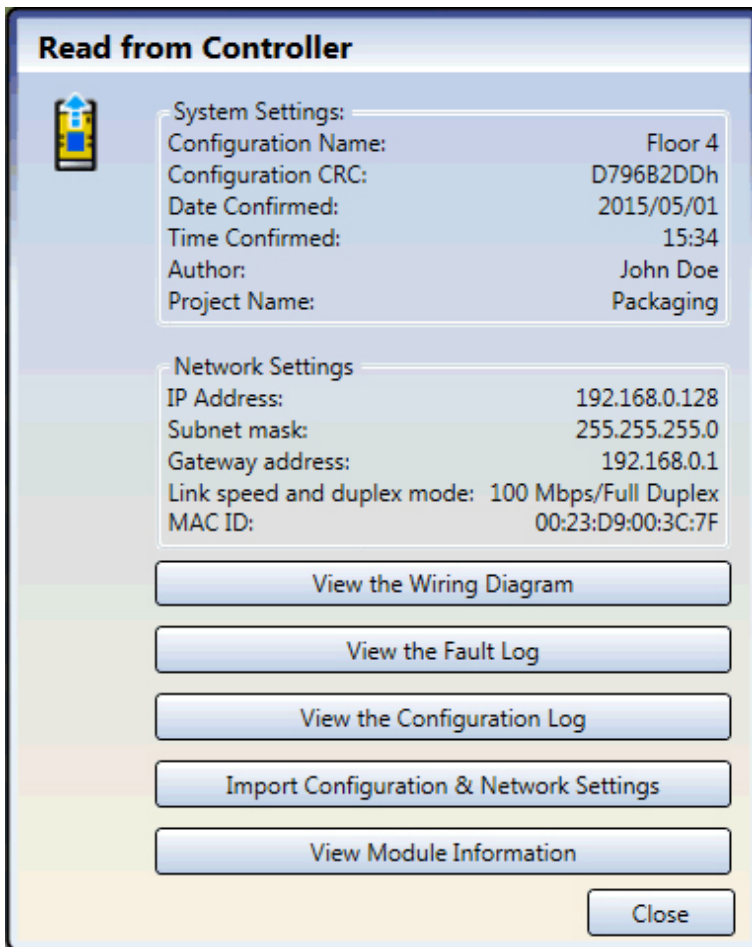

Viewing and Importing Controller Data

Click **Read from Controller** to view:

- **Wiring Diagram**—Removes all other tabs and worksheets from the Software and displays only **Wiring Diagram** and **Equipment** tabs
- **Fault Log**—History of the last 10 faults



Note: Fault Log numbering increases up to 4,294,967,295 unless the Safety Controller power cycle is performed, in which case the numbering is reset to start at 1. Clearing the Fault Log (either via the Software or the onboard interface) removes the log history but retains the numbering.

- **Configuration Log**—History of up to 10 most recent configurations (only the current configuration can be viewed or imported)
- **Module Information**

Click **Import Configuration & Network Settings** to access the current Safety Controller configuration and network settings (depends on user access rights, see [XS/SC26 Password Manager](#) on page 125 or [SC10-2 Password Manager](#) on page 126).

9.16 Live Mode

Live Mode is available when a Safety Controller is connected to the PC via USB.

Figure 103. Run Time—XS/SC26 *Live Mode* Tab

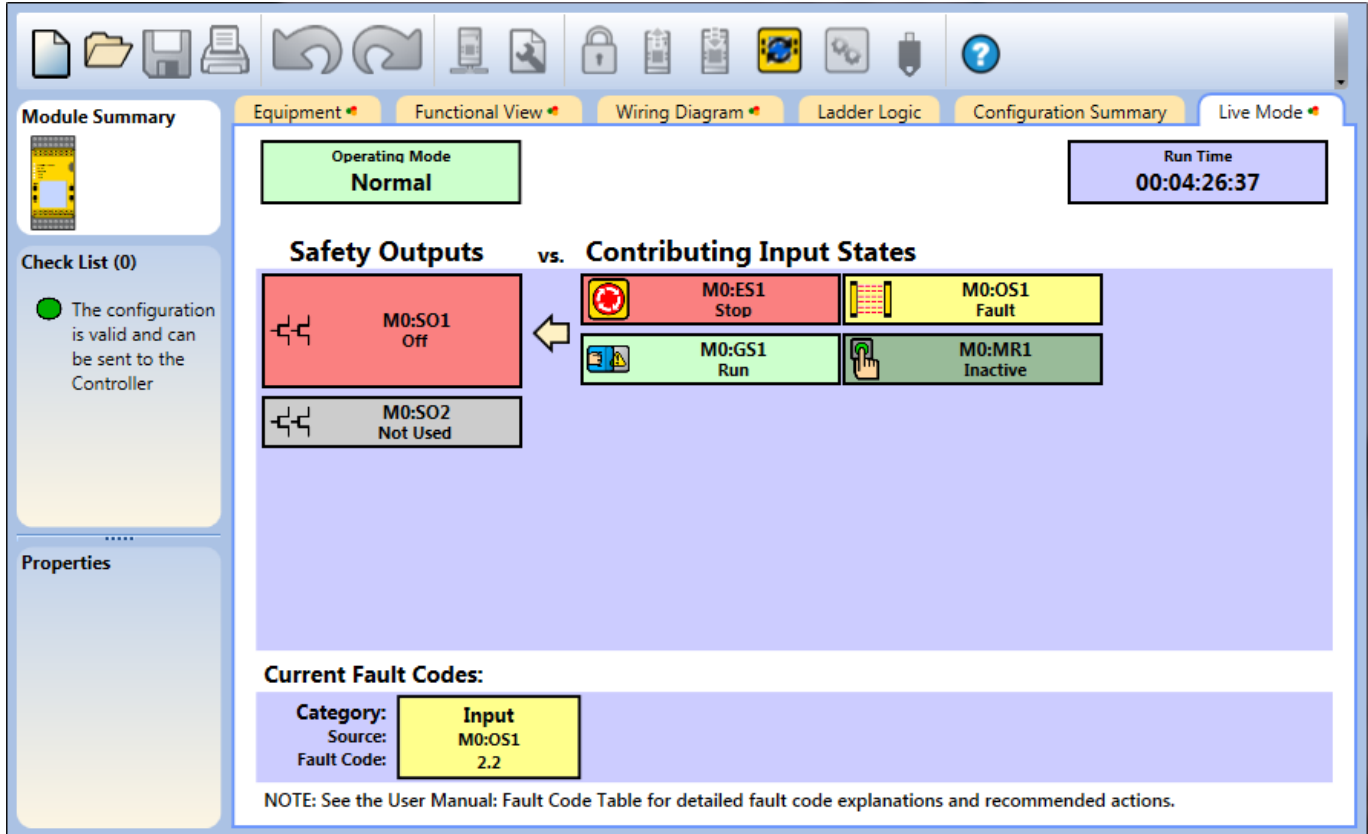

The screenshot displays the 'Live Mode' tab in a software application. The interface includes a toolbar at the top with various icons for file operations and system functions. Below the toolbar, there are several tabs: 'Equipment', 'Functional View', 'Wiring Diagram', 'Ladder Logic', 'Configuration Summary', and 'Live Mode'. The 'Live Mode' tab is active and shows the following information:

- Operating Mode:** Normal (indicated by a green box).
- Run Time:** 00:04:26:37 (displayed in a purple box).
- Safety Outputs vs. Contributing Input States:**
 - Safety Outputs:**
 - M0:SO1 Off (red box with a stop icon)
 - M0:SO2 Not Used (grey box)
 - Contributing Input States:**
 - M0:ES1 Stop (red box with a stop icon)
 - M0:GS1 Run (green box with a run icon)
 - M0:OS1 Fault (yellow box with a fault icon)
 - M0:MR1 Inactive (green box with an inactive icon)
- Current Fault Codes:**
 - Category: Input
 - Source: M0:OS1
 - Fault Code: 2.2

A note at the bottom states: "NOTE: See the User Manual: Fault Code Table for detailed fault code explanations and recommended actions."

The **Live Mode** tab becomes accessible when  **Live Mode** is clicked on the toolbar. Enabling **Live Mode** disables configuration modification on all other tabs. The **Live Mode** tab provides additional device and fault information, including a fault code (see [XS/SC26 Fault Code Table](#) on page 335 and [SC10-2 Fault Code Table](#) on page 340 for the description and possible remedies). The Run-time data is also updated on the **Functional View**, **Equipment**, and **Wiring Diagram** tabs providing the visual representation of the device states.

Figure 104. Run Time—Equipment Tab

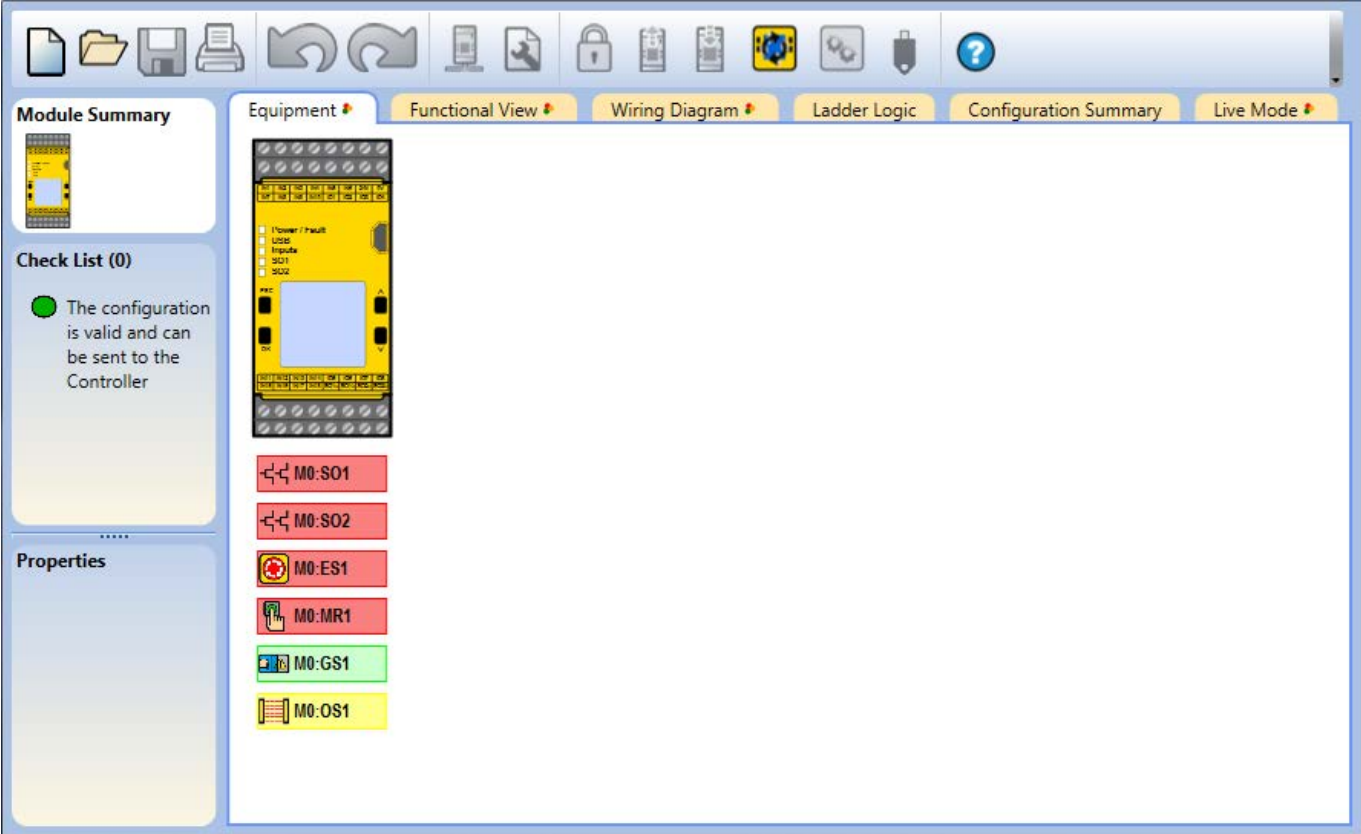

Figure 105. Run Time—Functional View Tab

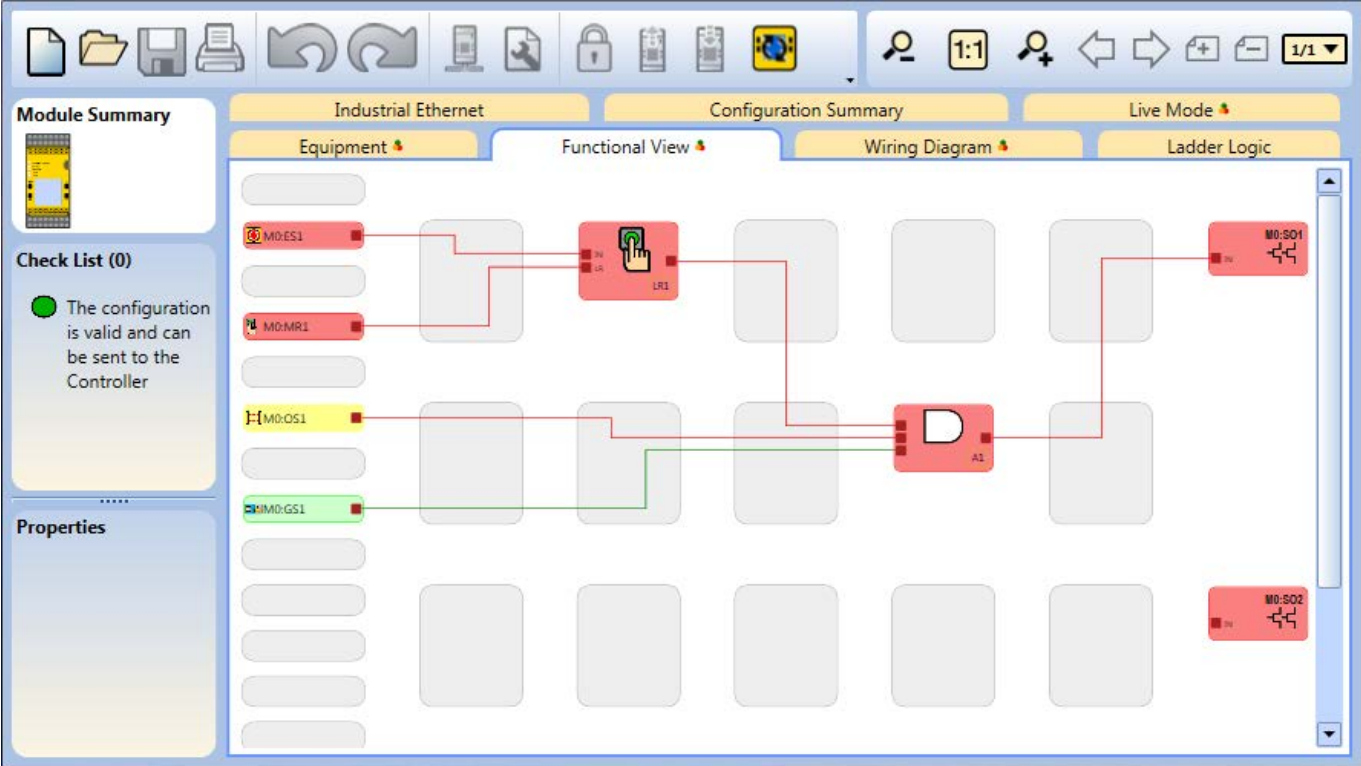

Figure 106. Run Time—Wiring Diagram Tab

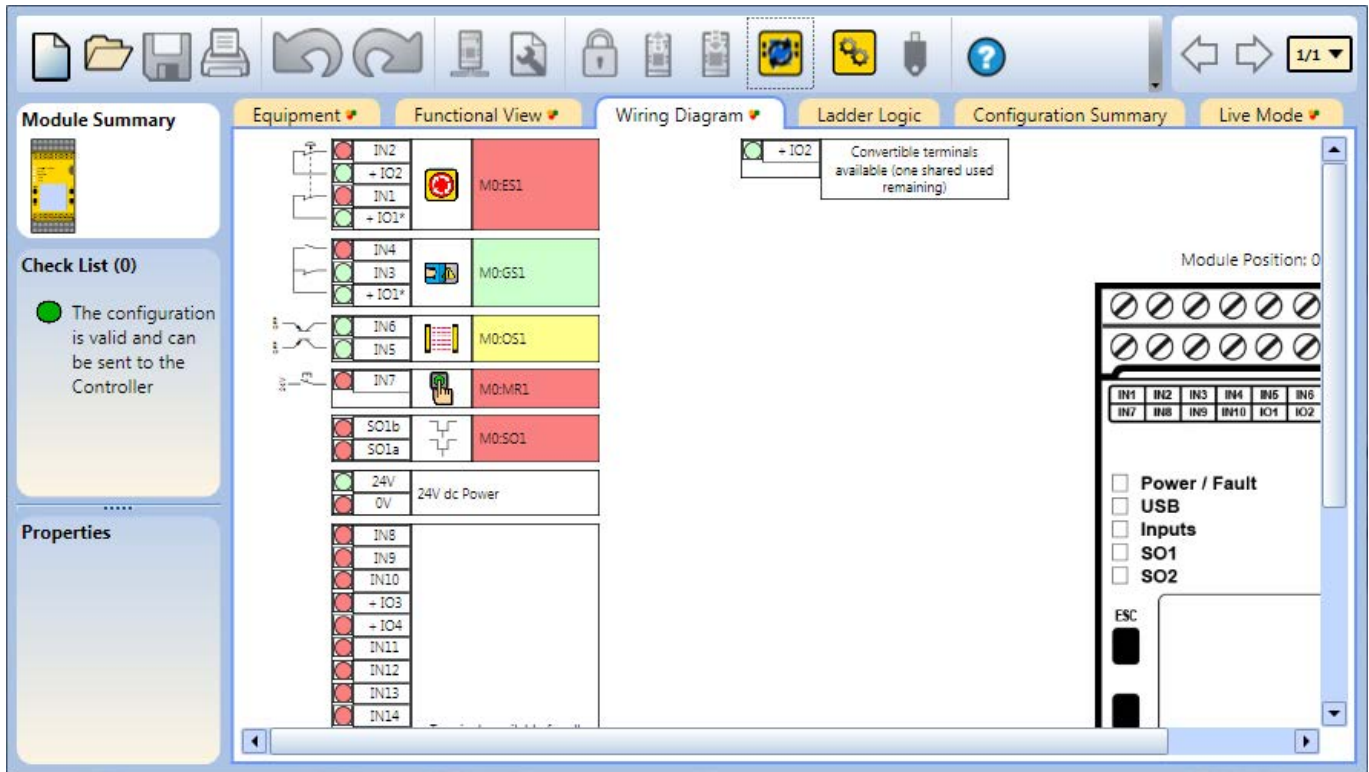
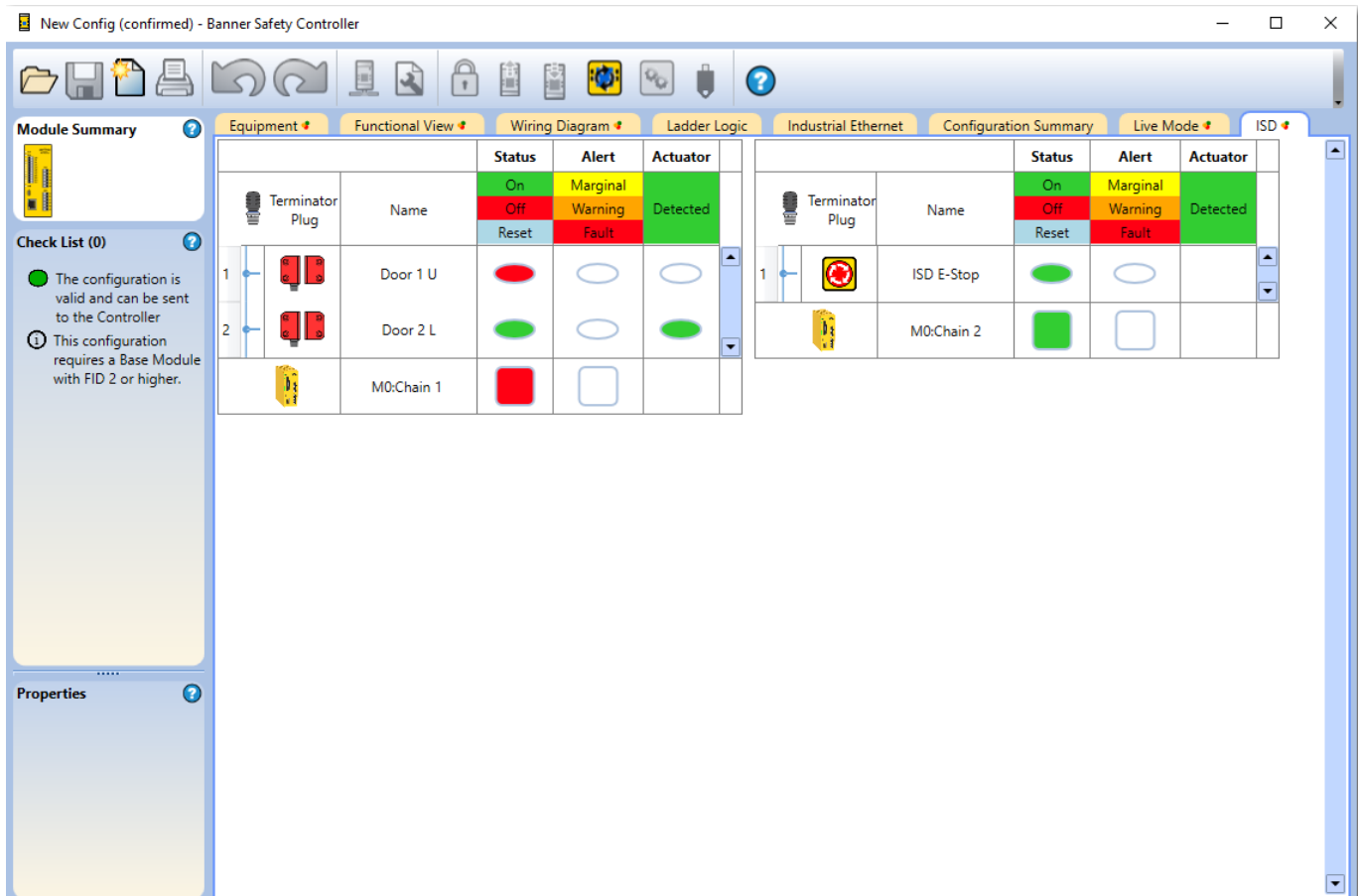
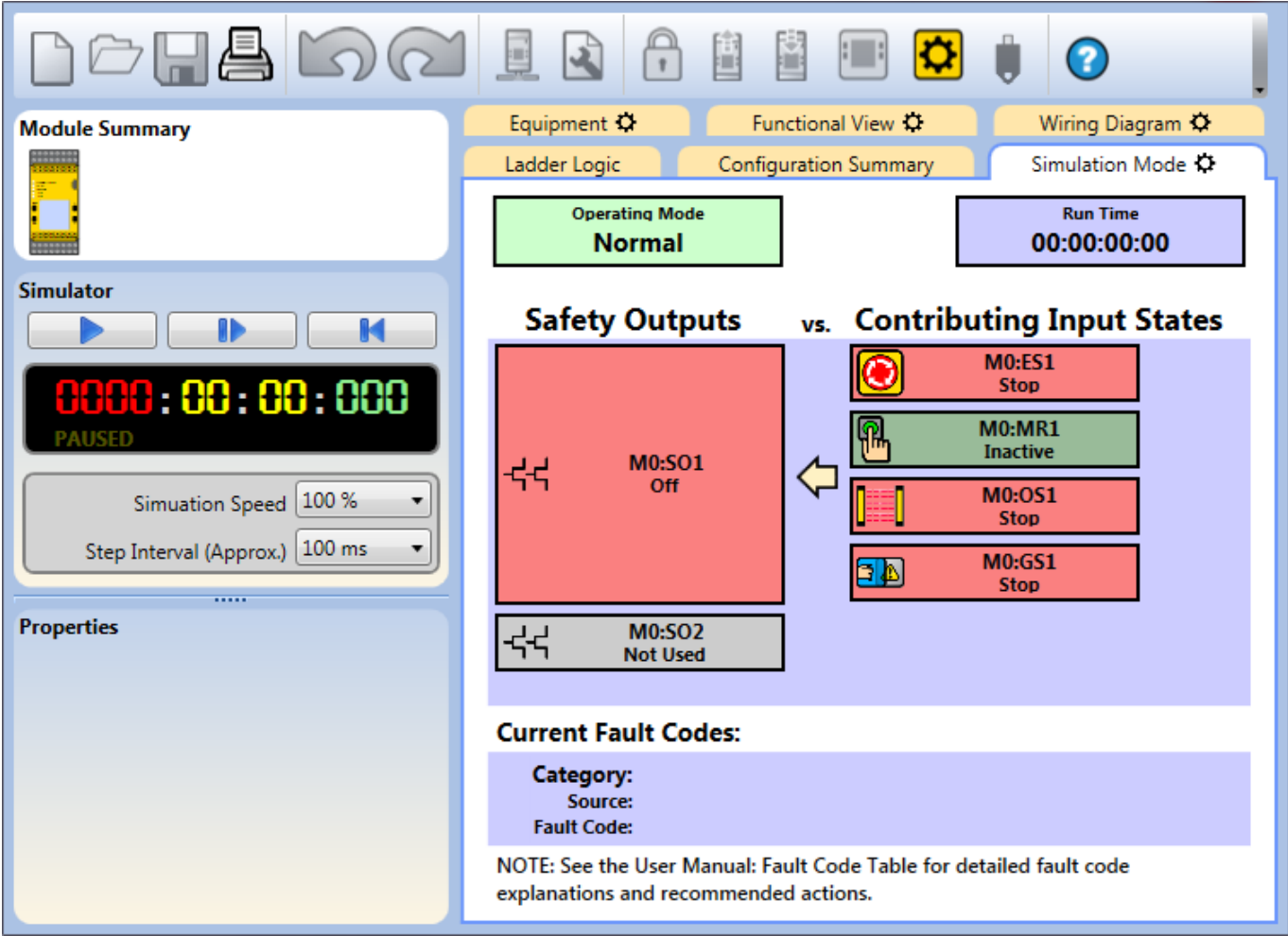



Figure 107. Run Time—ISD Tab



9.17 Simulation Mode

Figure 108. Simulation Mode



The **Simulation Mode** tab becomes accessible when  **Simulation Mode** is clicked on the toolbar. Simulation Mode options become available on the left side of the screen. The **Simulation Mode** tab contains view only information; you cannot click on the output or input items in this view.

 **Note:** For ISD inputs, individual devices are not simulated, only the final output that is connected to the ISD input terminals is simulated (on or off).



[Play/Pause] Starts the simulation time running at the specified simulation speed or temporarily stops the simulation time.



[Single Step] Advances the simulation time at the specified step interval.



[Reset] Resets the timer to zero and the equipment to the initial stop state.

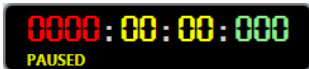

[Timer] Displays elapsed time in hours, minutes, seconds, and thousandths of a second.

Simulation Speed—Sets the speed of the simulation.

- 1%
- 10%
- 100% (default speed)
- 500%
- 2,000%

Step Interval—Sets the amount of time that the Single Step button advances when pressed. The amount of time is based on the size of the configuration.

Press **Play** to begin the simulation. The timer runs and gears spin to indicate that the simulation is running. The **Functional View**, **Equipment**, and **Wiring Diagram** tabs update, providing visual representation of the simulated device states as well as allowing testing of the configuration. Click on the items to be tested; their color and state change accordingly. Red indicates the Stop or off state. Green indicates the Run or on state. Yellow indicates a Fault state. Orange indicates that the input was turned on before the initial start of the simulation. Due to a start-up off test requirement, the input must be seen as off before it can be recognized as on.

Figure 109. Simulation Mode—Equipment Tab

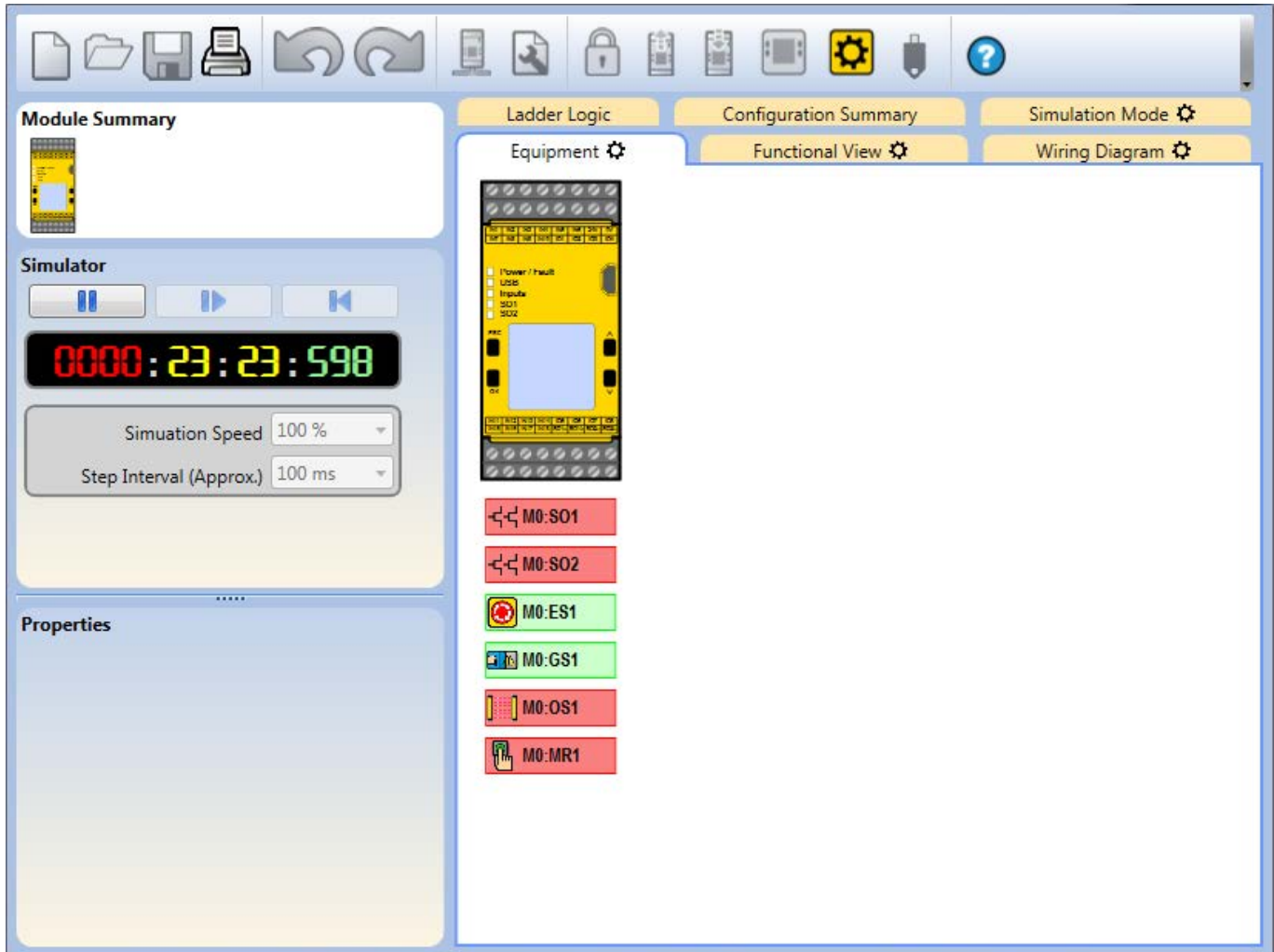
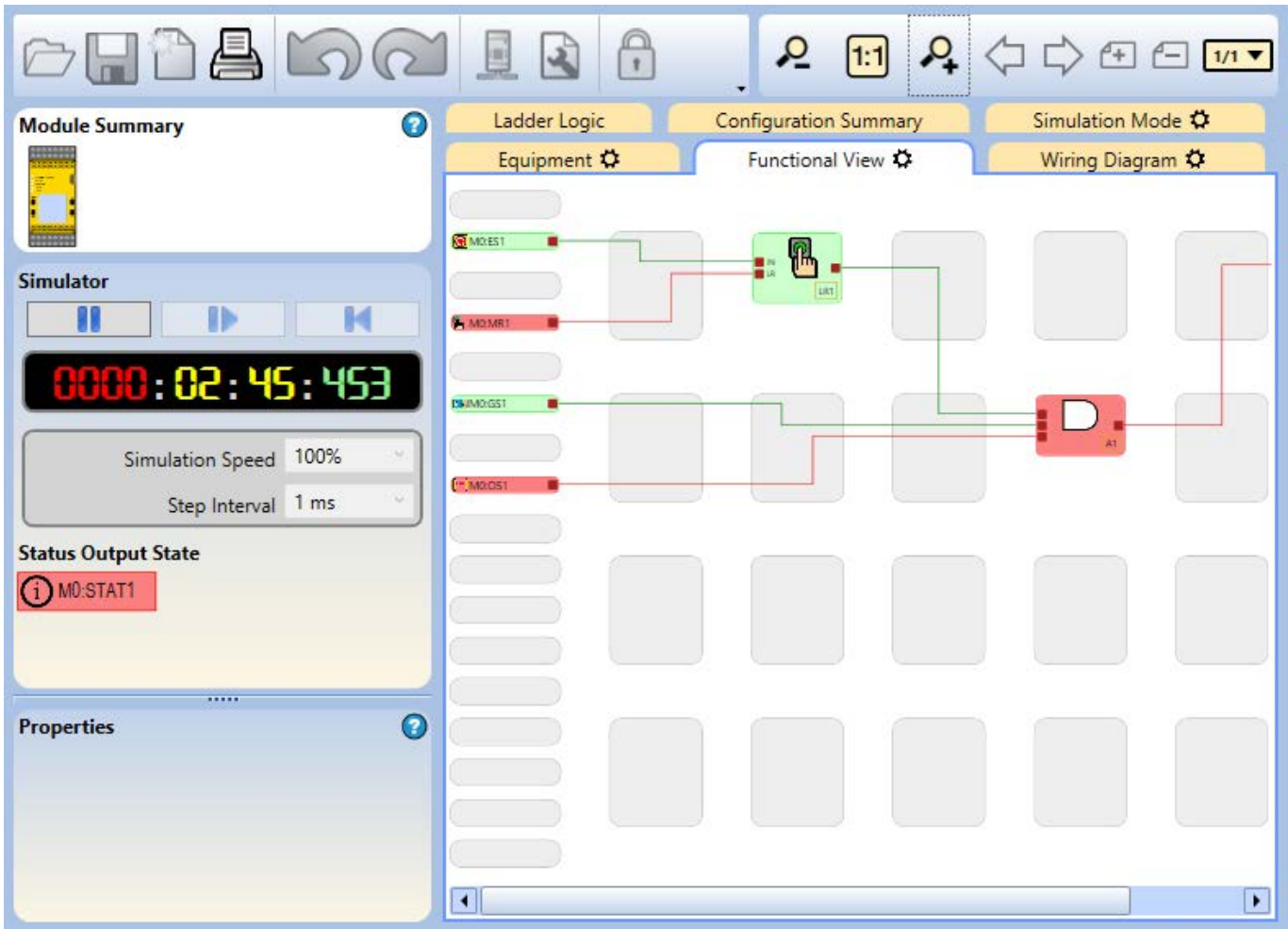

Figure 110. Simulation Mode—Wiring Diagram Tab

The screenshot displays the software interface in Simulation Mode, specifically the Wiring Diagram Tab. The interface is organized into several sections:

- Toolbar:** Located at the top, it contains icons for file operations (save, print), navigation (back, forward), simulation control (play, stop, reset), and help.
- Module Summary:** A panel on the left showing a small image of the safety controller module.
- Simulator:** A panel below the Module Summary featuring a digital display showing the time **0000:24:12:302**, and controls for Simulation Speed (set to 100%) and Step Interval (Approx.) (set to 100 ms).
- Properties:** A panel at the bottom left, currently empty.
- Diagram Area:** The central workspace, divided into tabs: Ladder Logic, Configuration Summary, Simulation Mode, Equipment, Functional View, and Wiring Diagram. The Wiring Diagram tab is active, showing a terminal block with the following connections:
 - Inputs (Green):** IN2, +IO2*, IN1, +IO1* (connected to M0:ES1); IN4, +IO2*, IN3, +IO1* (connected to M0:GS1).
 - Outputs (Red):** +IO5, IN5 (connected to M0:OS1); +IO6 (connected to M0:MR1); SO1a, SO1b (connected to M0:SO1).
 - Power:** 24V and 0V terminals labeled "24V dc Power".
- Terminal List:** A vertical list on the right side of the diagram area, showing terminals IN6 through IN18, +IO3, +IO4, +IO7, +IO8, and SO2a, SO2b. A note indicates "Terminals available for all circuit types".

Figure 111. Simulation Mode—Functional View Tab



9.17.1 Timed Action Mode

While in Simulation Mode and on the **Functional View** tab, certain elements which are in delay action modes are indicated in purple. The progress bar shows the countdown of the associated timer for that element.

The following figures show the different element states:

Figure 112. Safety output in Delay Off Timing mode



Figure 113. Muting Block in Timed Muting mode

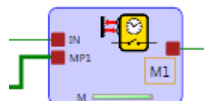
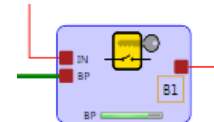

Figure 114. Bypass Block in Timed Bypass mode



Note: The M next to the progress bar indicates the progress bar indicates Timer Muting.

Figure 115. Delay Block—XS/SC26 FID 2 or later Base Controllers only and SC10-2

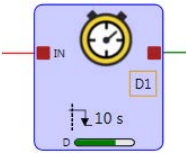

Figure 116. One Shot Block—XS/SC26 FID 4 or later Base Controllers only



9.18 Reference Signals



Important: The configuration software incorporates Reference Signals that represent the state of Safety Controller outputs, input devices and both Function and Logic Blocks. A Safety Output reference signal can be used to control another Safety Output. In this type of configuration, the physical On state of the controlling Safety Output is not known. If the Safety Output On state is critical for the application safety, an external feedback mechanism is required. Note that the safe state of this Safety Controller is when the outputs are turned Off. If it is critical that Safety Output 1 is On before Safety Output 2 turns On, then the device that is being controlled by the Safety Output 1 needs to be monitored to create an input signal that can be used to control Safety Output 2. The Safety Output 1 reference signal may not be adequate in this case.

Figure 117 on page 135 shows how one Safety Output can control another Safety Output. When Manual Reset **M0:MR1** is pressed, it turns On Safety Output **M0:SO2**, which, in turn, turns On Safety Output **M0:SO1**.

Figure 117. Safety Output controlled by another Safety Output

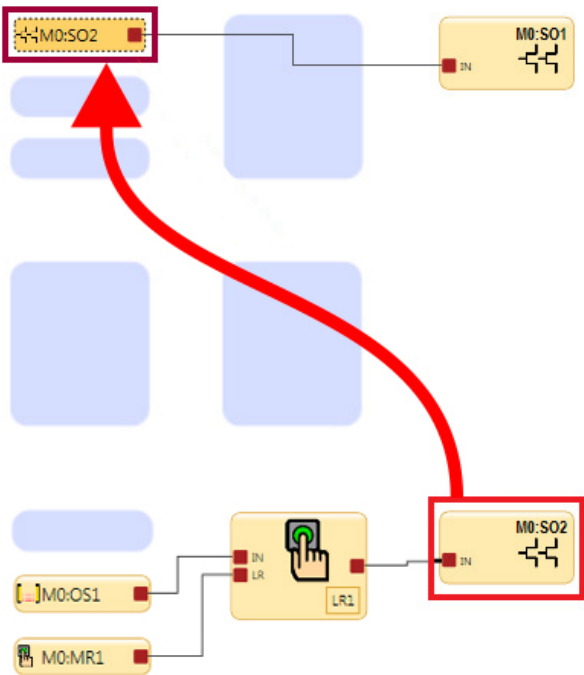

10 Function Block Descriptions

The following sections describe the available Function Blocks in detail.

10.1 Bypass Block

Default Nodes	Additional Nodes	Notes
IN BP	-	When the BP node is inactive, the safety signal simply passes through the Bypass Block. When the BP node is active, the output of the block is On regardless of the state of the IN node (if the Output turns Off when both inputs (IN&BP) are On checkbox is clear). The Bypass Block output turns Off when the bypass timer expires.

Figure 118. Timing Diagram—Bypass Block

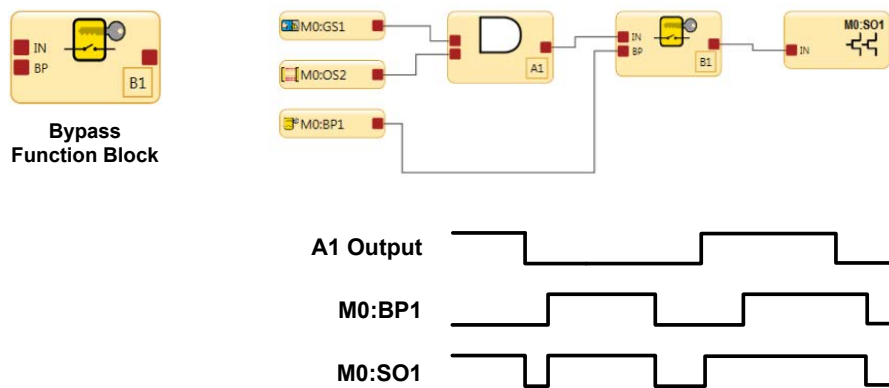

Bypass Time Limit

A bypass function time limit must be established to limit how long the safety input device bypass is active. The time limit can be adjusted from 1 second (default) to 12 hours and cannot be disabled. Only one time limit can be set, and this limit will apply to all safety devices that are bypassed. At the end of the time limit, the safety output control authority is transferred back to the bypassed safety input devices.

Two-Hand Control Bypassing

The Safety Controller issues a Stop signal if a Two-Hand Control input is actuated while the input is being bypassed. This ensures that the operator does not mistakenly assume that the Two-Hand Control is functional; unaware that the Two-Hand Control is bypassed and no longer providing the safeguarding function.

10.1.1 Lockout/Tagout

Hazardous energy must be controlled (lockout/tagout) in machine maintenance and servicing situations in which the unexpected energization, start up, or release of stored energy could cause injury.

Refer to OSHA 29CFR 1910.147, ANSI 2244.1, ISO 14118, ISO 12100 or other relevant standards to ensure that bypassing a safeguarding device does not conflict with the requirements that are contained within the standards.



WARNING:

- **Limit the use of the bypass and/or override function**
- Failure to follow these instructions could result in serious injury or death.
- The bypass and/or override function is not intended for production purposes; use it only for temporary or intermittent actions, such as to clear the defined area of a safety light curtain if material becomes stuck. When bypass and/or override is used, the user must install and use it according to applicable standards (such as NFPA 79 or IEC/EN60204-1).

Safe Working Procedures and Training

Safe work procedures provide the means for individuals to control exposure to hazards through the use of written procedures for specific tasks and the associated hazards. The user must also address the possibility that an individual could bypass the safeguarding device and then either fail to reinstate the safeguarding or fail to notify other personnel of the bypassed

condition of the safeguarding device; both cases could result in an unsafe condition. One possible method to prevent this is to develop a safe work procedure and ensure personnel are trained and correctly follow the procedure.

10.2 Delay Block

The Delay Block allows a user-configurable ON- or OFF-Delay of a maximum of 5 minutes, in 1 ms increments. This feature is available on XS/SC26 FID 2 and later and SC10-2.

Default Nodes	Additional Nodes	Notes
IN	CD	Depending on the selection, a signal/state transition on the input node will be delayed by the output delay time by either holding the output OFF (ON-Delay) or holding the output ON (OFF-Delay) after a signal transition.

 **Note:** The actual delay time of a delay function block or a safety output with a delay can be up to 1 scan time longer than the delay setting. Multiple delay blocks or delay outputs in series will increase the final delay time by up to 1 scan for each delay function. For example, three 100 ms off delay function blocks in series and a scan time of 15 ms may result in an actual delay time of up to 345 ms (300 ms + 45 ms).

The Cancel Delay Node is a configurable node if OFF-Delay is selected.

Figure 119. Delay Block Timing Diagram

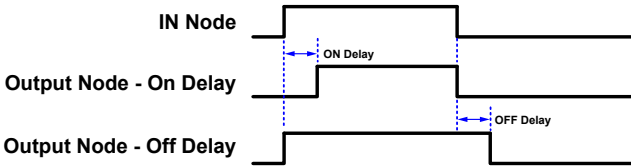

CAUTION: Delay time effect on response time
 The OFF-Delay time may significantly increase the safety control response time. This will affect the positioning of safeguards whose installation is determined by the safety (minimum) distance formulas or are otherwise influenced by the amount of time to reach a non-hazardous state. The installation of safeguards must account for the increase in response time.



Note: The response time provided on the **Configuration Summary** tab is a maximum time that can change depending on the use of delay blocks and other logic blocks (such as OR functions). It is the user's responsibility to determine, verify, and incorporate the appropriate response time.

Figure 120. Delay Block Properties

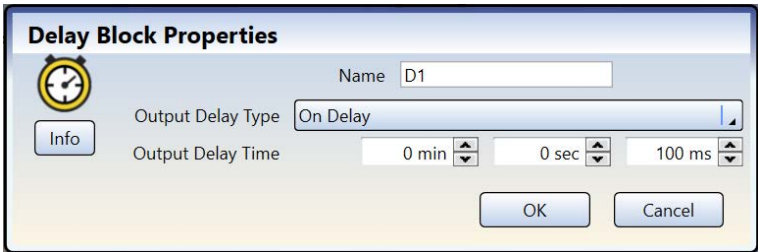

The **Delay Block Properties** window allows the user to configure the following:

Name
 Create a name of up to 10 characters for the function block.

- Output Delay Type**
 This is the Output Delay Type
- None
 - OFF-Delay
 - ON-Delay

Output Delay Time

Available when the Safety Output Delay is set to either OFF-Delay or ON-Delay
 Delay time: 1 ms to 5 minutes, in 1 ms increments. The default setting is 100 ms.

Cancel Type

Available when the Safety Output Delay is set to OFF-Delay.

- Do Not Cancel
- Control Input (The delay block output stays on if the input turns ON again before the end of the delay.)
- Cancel Delay Node

End Logic

Available when the Cancel Type is set to Cancel Delay Node.

- Keep Output ON
- Turn Output OFF

10.3 Enabling Device Block

Default Nodes	Additional Nodes	Notes
ED IN RST	ES JOG	An Enabling Device Block must be connected directly to an Output Block. This method assures that the final control of the outputs is given to the operator holding the Enabling Device (ED). Use the ES node for safety signals that should not be bypassed by the ED node. If no other inputs of the function block are configured, using an Enabling Device function block is not required.

Figure 121. Timing Diagram—Enabling Device, Simple Configuration

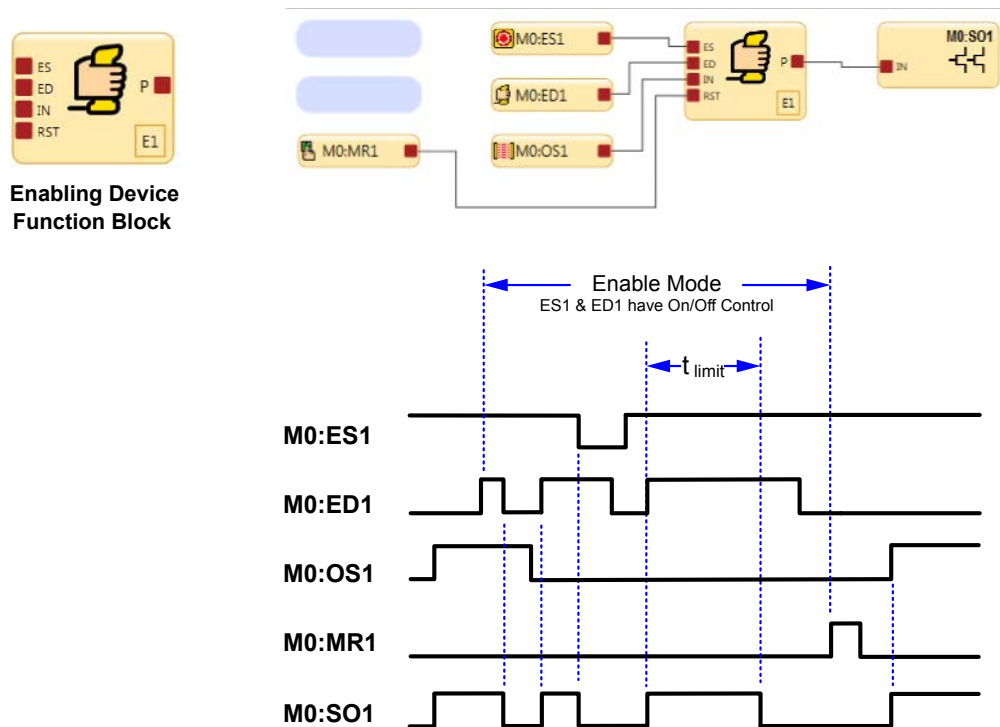
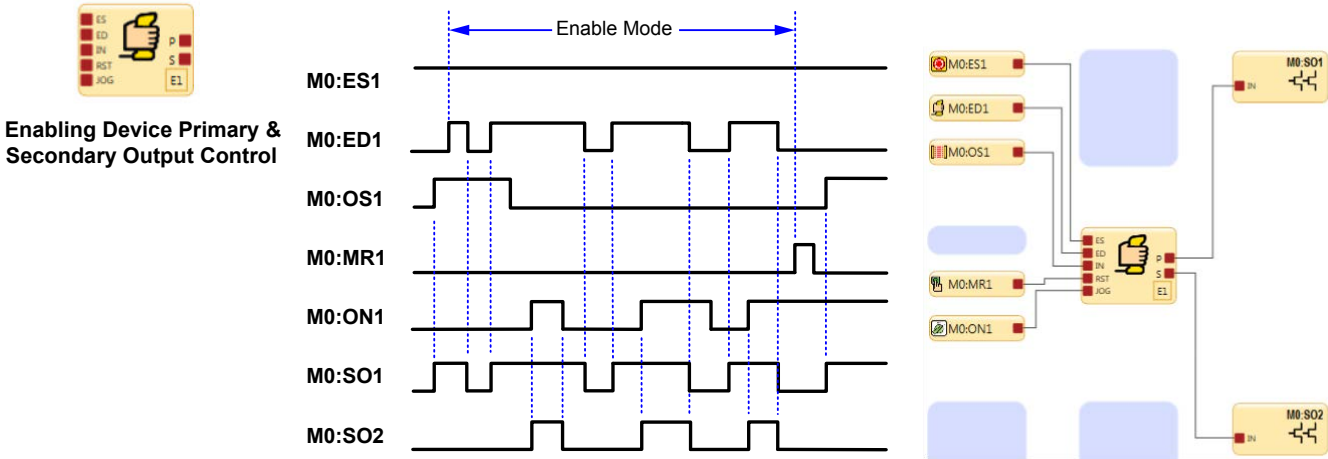

Figure 122. Timing Diagram—Enabling Device



E1 enabling mode starts when the Enabling Device ED1 is switched to the Run state. ED1 and ES input devices have On/Off control authority while in Enable mode. When MR1 is used to perform a reset, the normal Run mode is re-established and OS1 and ES1 have the On/Off control authority.

To exit the Enable mode, the enabling device must be in the OFF state, and an Enabling Device Block reset must be performed.

The enabling device time limit may be adjusted between 1 second (default) and 30 minutes and cannot be disabled. When the time limit expires, the associated safety outputs turn OFF. To start a new Enable mode cycle, with the time limit reset to its original value, the enabling device must switch from ON to OFF, and then back to ON.

All ON- and OFF-delay time limits associated with the safety outputs that are controlled by the enabling device function are followed during the Enable mode.

10.4 Latch Reset Block

Default Nodes	Additional Nodes	Notes
IN LR	RE	The RE (Reset Enable) node can be used to enable or disable the Latch Reset function. If the input devices connected to the IN node are all in the Run state and the RE input signal is high, the LR function block can be manually reset to have its output turn ON. See Figure 123 on page 140 with Reference Signal SO2 connected to the RE node.

Figure 123. Timing Diagram—Latch Reset Block

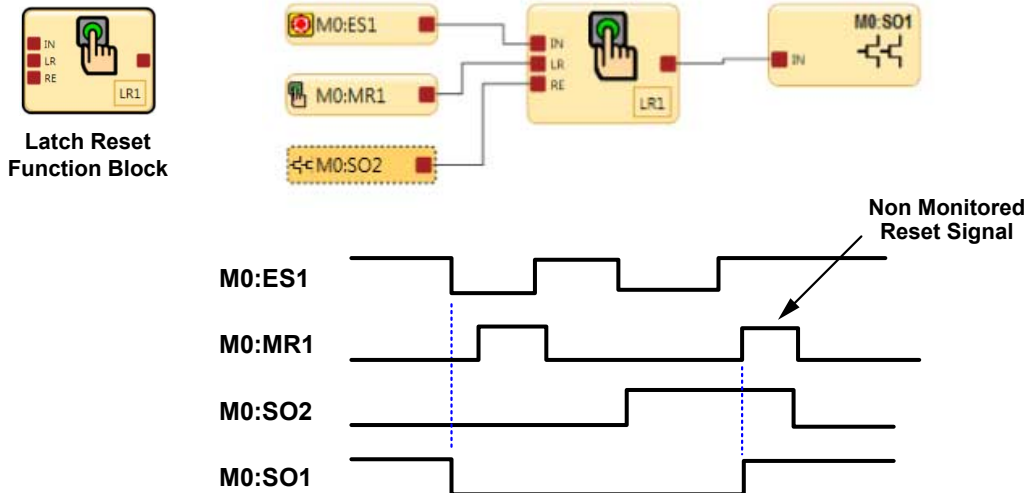

The Latch Reset function block LR1 will turn its output and the safety output SO1 Off when the E-Stop button changes to the Stop state. The latch off condition can be reset when the Reset Enable RE of LR1 detects that the SO2 reference signal is in the Run state & MR1 is used to perform a reset.

Figure 124. Timing Diagram—Latch Reset Block, Monitored/Non-Monitored Reset

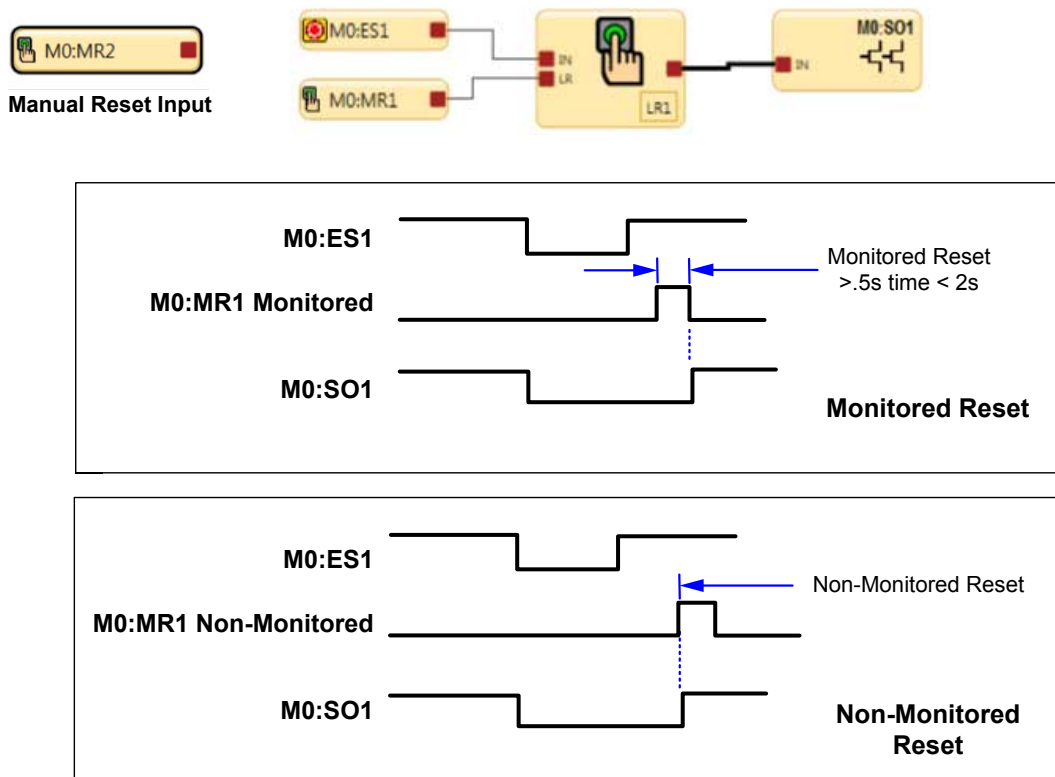

The Manual Reset input device can be configured for one of two types of reset signals: Monitored & Non-Monitored

Figure 125. Timing Diagram—Latch Reset Block and Referenced Safety Output

M0:SO2

Reference Signals

- A Reference Signal is used to:
- Control an output based on the state of another output
 - Represent the state of an output, input, safety function or logic block on another page.

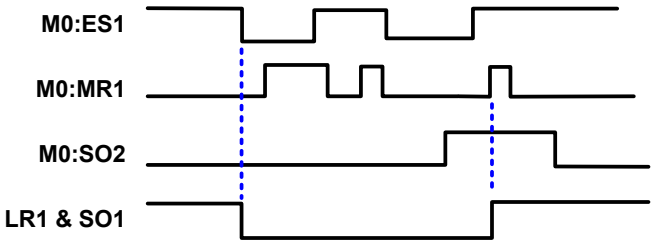
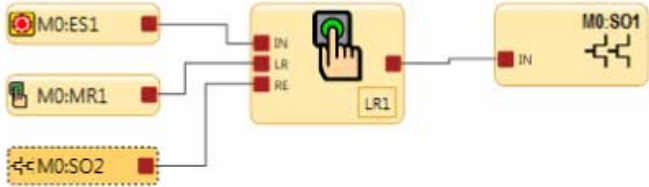

When output SO2 is On, the SO2 reference signal state is On or High. The function block above shows reference signal SO2 connected to the Reset Enable node RE of Latch Reset Block LR1.

LR1 can only be reset (turned On) when ES1 is in the Run state and SO2 is On.

See [Reference Signals](#) on page 135 for use of referenced Safety Outputs.

Figure 126. Latch Reset and Referenced Safety Output and AND block



Reference Signals

In the figure below, reference signal A3 is on page 1 of the function block diagram and the A3 AND block is on page 2. The output node on the A3 AND block can also be used on page 2 for other safety control logic.

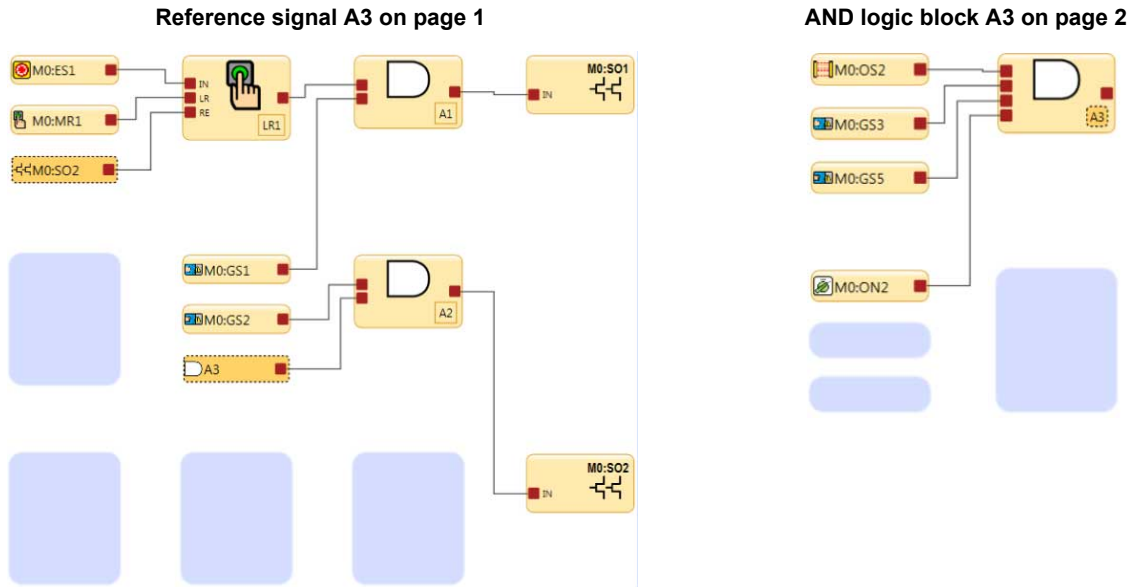
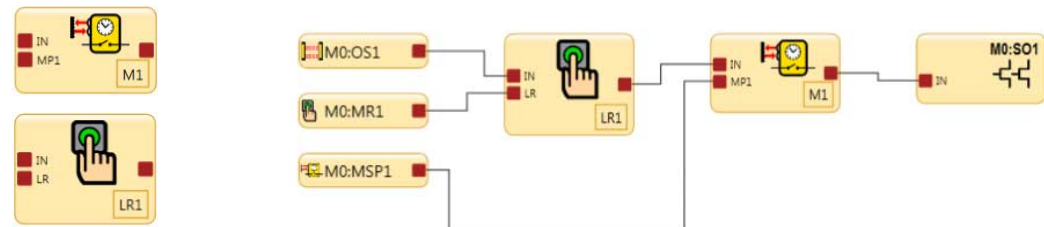
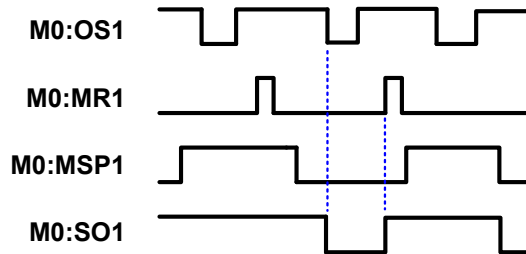

Figure 127. Timing Diagram—Latch Reset Block and Muting Block



Latch Reset Mute Function



When a safeguarding device OS1 transitions to a Stop state in a valid muting cycle, the latch reset function block will latch and require a reset signal to keep SO1 on after muting ends.

If OS1 switches to the Stop state in a valid muting cycle and no reset signal is seen, SO1 turns off after muting ends.

10.5 Muting Block

Default Nodes	Additional Nodes	Notes
IN MP1	ME BP MP2	Muting Sensor Pair input blocks must be connected directly to the Muting function block.

Figure 128. Muting Block—Function Types

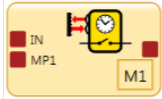

Mute Function Block

There are five Mute Function types listed below. The following timing diagrams show the function detail and sensor/safeguarding state change order for each mute function type.

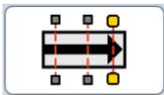

One Way - 1 Mute Sensor Pair

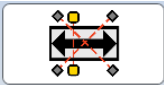

Two Way - 1 Mute Sensor Pair

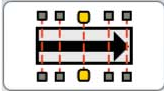

One Way - 2 Mute Sensor Pair

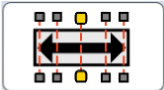

Two Way - 2 Mute Sensor Pair



Two Way - 1 Mute Sensor Pair

Figure 129. Muting Block—Bypass/Override Mode Options

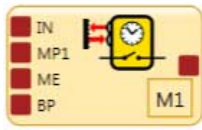

- There are 2 types of Mute Bypass:
- Mute Dependent Override
 - Bypass (normal)

In the Mute Block Properties menu in the Advanced settings, if the Bypass check box is checked, the option to select a Bypass or a Mute Dependent Override is possible.

The Mute Dependent Override is used to temporarily restart an incomplete mute cycle (for example after the mute time limit expires). In this case, one or more mute sensors must be activated while the safeguard is in the Stop state.

The normal Bypass is used to temporarily bypass the safeguarding device to keep on or turn on the output of the function block.

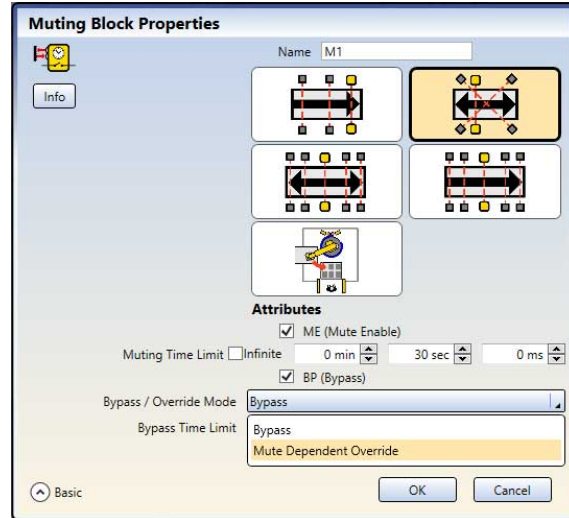

Figure 130. Mute-Dependent Override

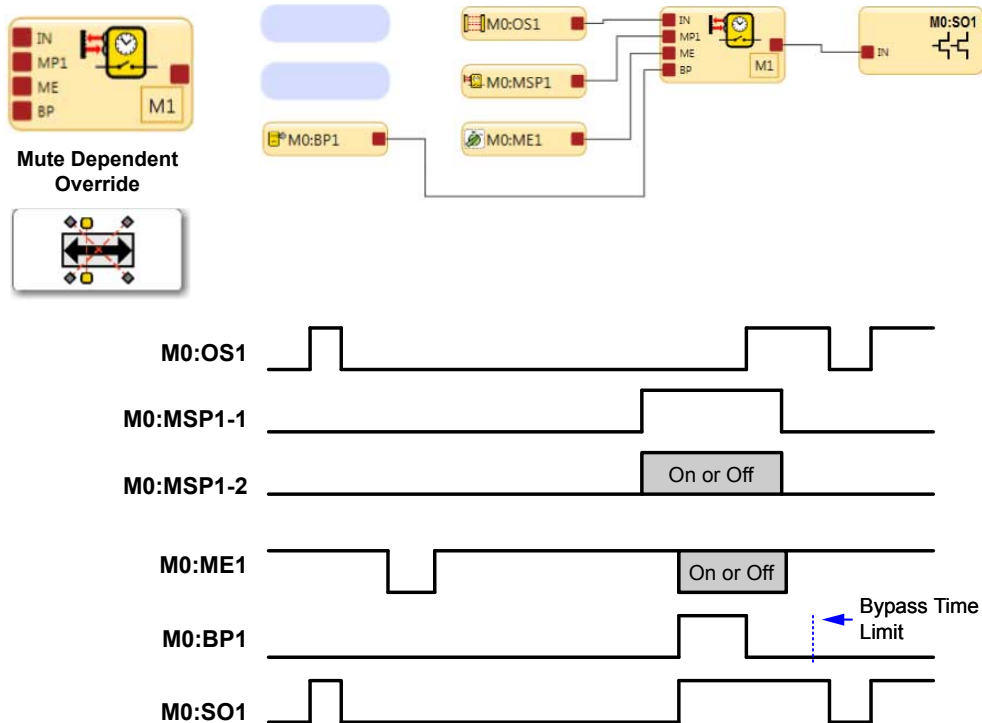

Figure 131. Mute Bypass

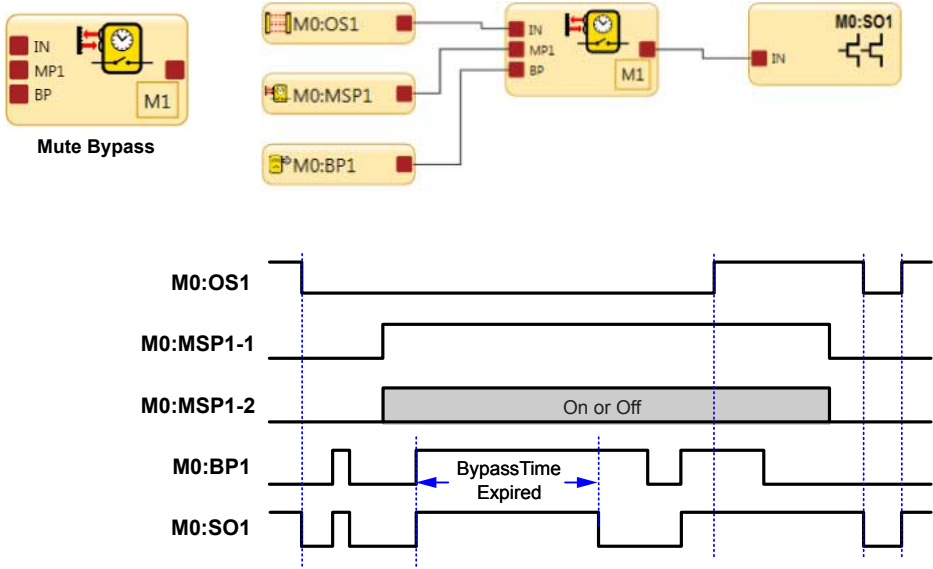
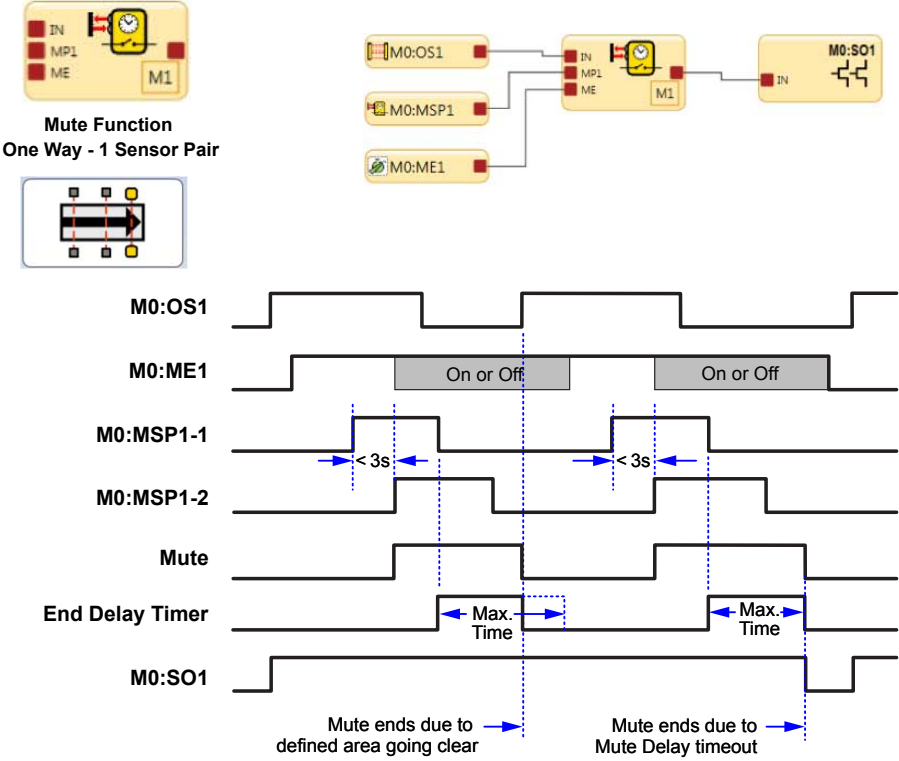

Figure 132. Timing Diagram—One-Way Muting Block, One Muting Sensor Pair



Note: M0:OS1 must be blocked before either MSP1-1 or MSP1-2 clears.

Figure 133. Timing Diagram—One-Way Muting Block, Two Muting Sensor Pairs

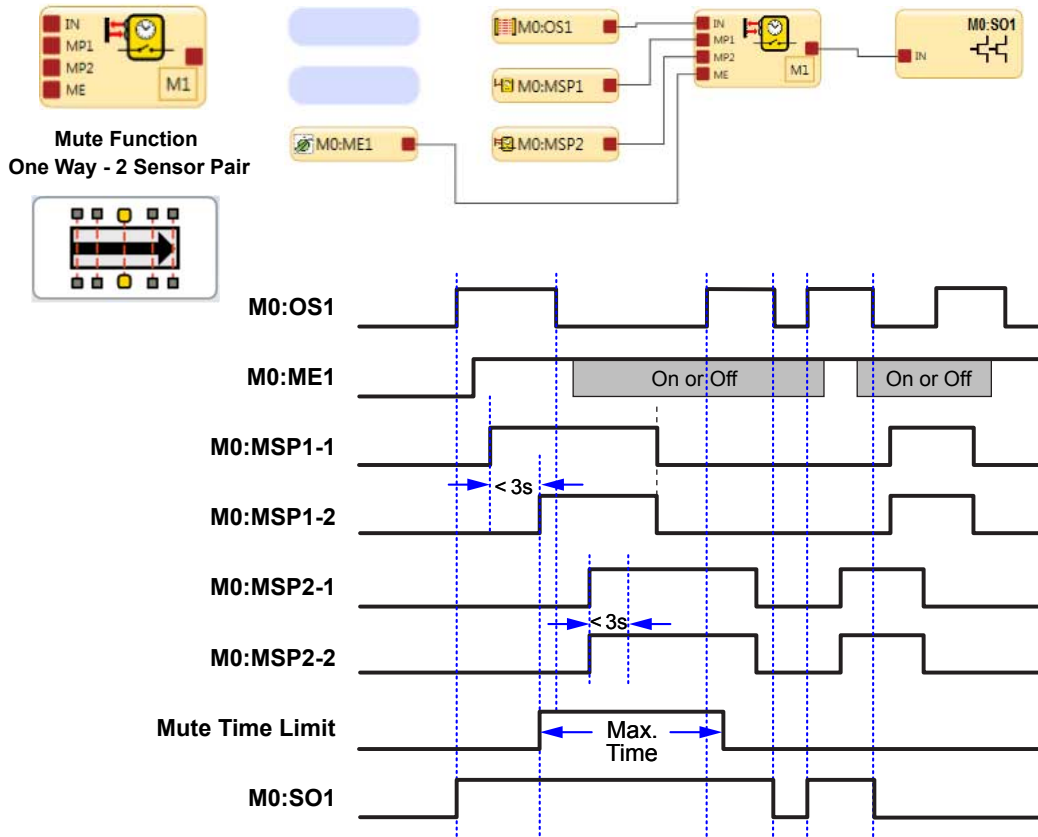

Figure 134. Timing Diagram—Two-Way Muting Block, One Muting Sensor Pair

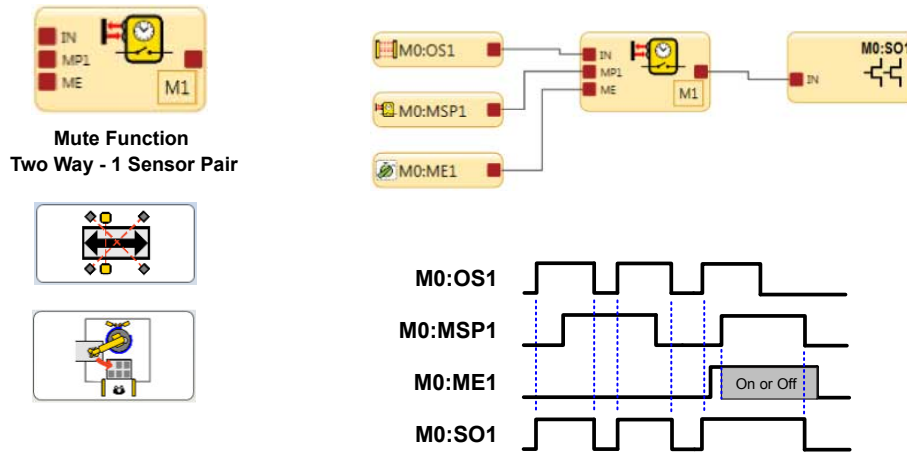
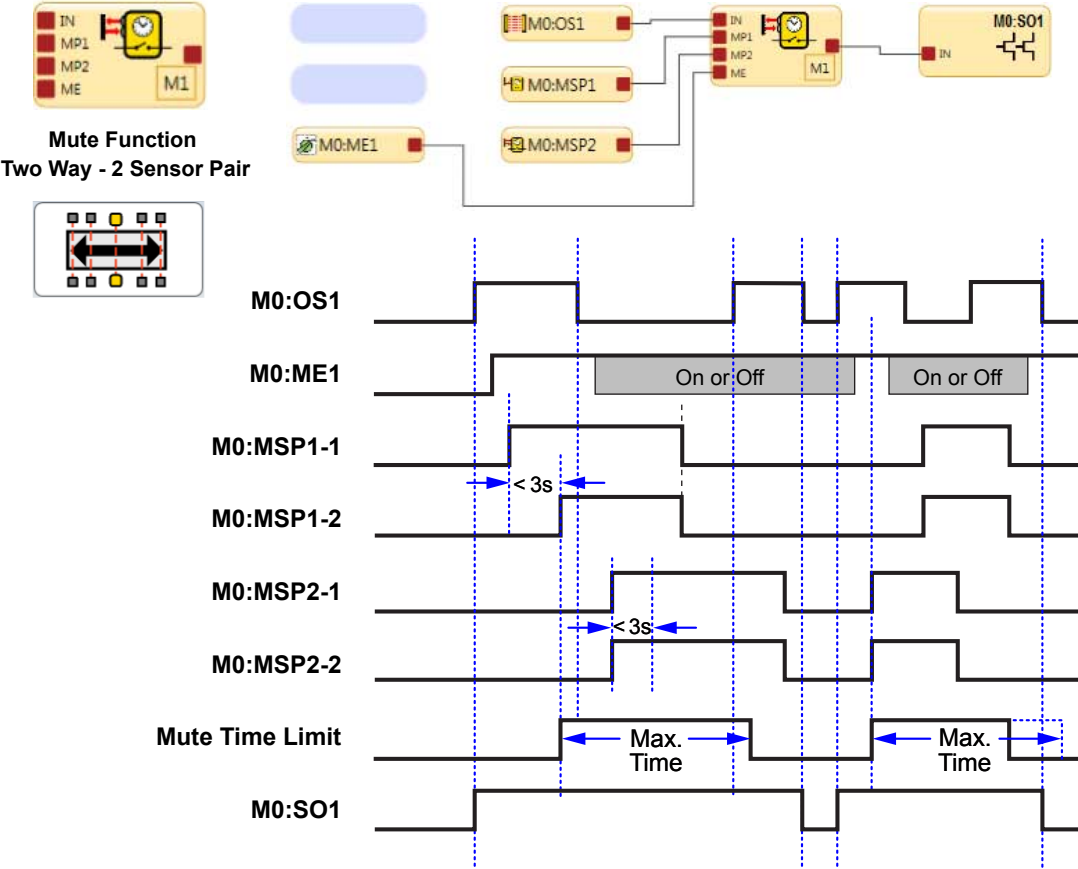

Figure 135. Timing Diagram—Two-Way Muting Block, Two Muting Sensor Pairs



**WARNING:****E-Stop Button control authority when using the Mute function****Improper E-Stop Control
NOT RECOMMENDED**

The configuration top right shows OS1 and E-Stop button ES1 with a Latch Reset LR1 connected to a mute function via the AND function. In this case both ES1 and OS1 will be muted.

If there is an active mute cycle in progress and the E-Stop button is pressed (switched to the Stop state), SO1 will not turn Off. This will result in a loss of safety control and may lead to a potential hazardous condition.

Proper E-Stop Control

The configuration to the right shows OS1 connected directly to the Mute block M1. M1 and ES1 are both inputs to AND A1. In this case both M1 and ES1 control SO1.

If there is a an active mute cycle in progress and the E-Stop button is pressed (switched to the Stop state), SO1 will turn Off.

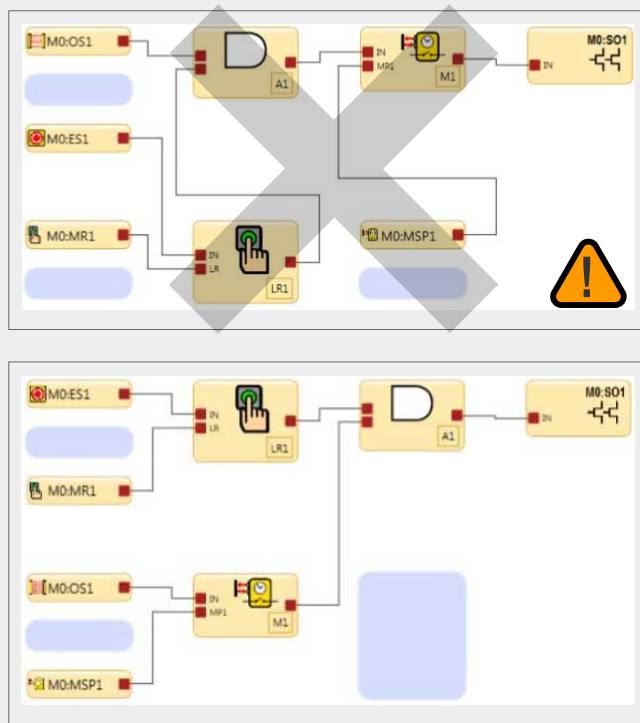

E-stop buttons, rope pulls, enabling devices, external device monitoring, and bypass switches are non-mutable devices or functions.

To mute the primary safeguard appropriately, the design of a muting system must:

1. Identify the non-hazardous portion of the machine cycle.
2. Involve the selection of the proper muting devices.
3. Include proper mounting and installation of those devices.

**WARNING:**

- **Use Mute and Bypass operations in a way that minimizes personnel risk.**
- Failure to follow these rules could cause an unsafe condition that could result in serious injury or death.
- Guard against unintended stop signal suspension by using one or more diverse-redundant mute sensor pairs or a dual-channel key-secured bypass switch.
- Set reasonable time limits for the mute and bypass functions.

The Safety Controller can monitor and respond to redundant signals that initiate the mute. The mute then suspends the safeguarding function by ignoring the state of the input device to which the muting function has been assigned. This allows an object or person to pass through the defined area of a safety light curtain without generating a stop command. This should not be confused with blanking, which disables one or more beams in a safety light curtain, resulting in larger resolution.

The mute function may be triggered by a variety of external devices. This feature provides a variety of options to design the system to meet the requirements of a specific application.

A pair of muting devices must be triggered simultaneously (within 3 seconds of one another). This reduces the chance of common mode failures or defeat. Directional muting, in which sensor pair 1 is required to be blocked first, also may reduce the possibility of defeat.

At least two mute sensors are required for each muting operation. The muting typically occurs 100 ms after the second mute sensor input has been satisfied. One or two pairs of mute sensors can be mapped to one or more safety input devices so that their assigned safety outputs can remain On to complete the operation.

**WARNING:**

- **Muting is allowed only during the non-hazardous portion of the machine cycle**
- Failure to follow these instructions could result in serious injury or death.
- Design the muting application so that no single component failure can prevent the stop command or allow subsequent machine cycles until the failure is corrected (per ISO 13849-1 and ANSI B11.19).

**WARNING:**

- **Muting inputs must be redundant**
- A single device, with multiple outputs, can fail so that the system is muted at an inappropriate time, causing a hazardous situation.
- Do not use a single switch, device, or relay with two normally open contacts for the mute inputs.

10.5.1 Optional Muting Attributes

The Muting Sensor Pair Input and the Muting Block have several optional functions that can be used to minimize an unauthorized manipulation and the possibility of an unintended mute cycle.

Mute Enable (ME)

The Mute Enable input is a non-safety-rated input. When the input is closed, or active for virtual input, the Safety Controller allows a mute condition to occur; opening this input while the System is muted will have no effect.

Typical uses for Mute Enable include:

- Allowing the machine control logic to create a period of time for muting to begin
- Inhibiting muting from occurring
- Reducing the chance of unauthorized or unintended bypass or defeat of the safety system

The optional Mute Enable function may be configured to ensure that a mute function is permitted only at the appropriate time. If a Mute Enable input device has been mapped to a Muting Block, the safety input device can be muted only if the mute enable switch is in the enable (24 V DC) state, or active state for virtual input, at the time the mute cycle is started. A mute enable input device can be mapped to one or more Muting Blocks.

Figure 136. Timing logic—One mute sensor pair with mute enable

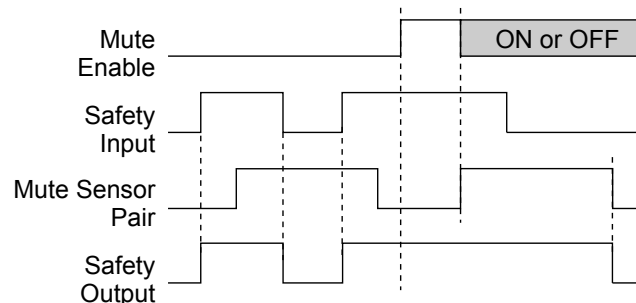

Simultaneity Timer Reset Function

The Mute Enable input can also be used to reset the simultaneity timer of the mute sensor inputs. If one input is active for longer than 3 seconds before the second input becomes active, the simultaneity timer prevents a mute cycle from occurring. This could be due to a normal stoppage of an assembly line that may result in blocking one mute device and the simultaneity time running out.

If the ME input is cycled (closed-open-closed or active-inactive-active for virtual input) while one mute input is active, the simultaneity timer is reset, and if the second mute input becomes active within 3 seconds, a normal mute cycle begins. The function can reset the timer only once per mute cycle (all mute inputs M1–M4 must open before another reset can occur).

Bypass

An optional **Bypass/Override Mode** may be enabled by checking the **BP (Bypass)** box in the **Muting Block** properties window. There are two available Bypass/Override Modes—**Bypass** and **Mute Dependent Override**. The **Bypass** mode is used to temporarily bypass the safeguarding device to keep On or turn On the output of the function block. The **Mute Dependent Override** mode is used to manually override an incomplete mute cycle (for example after the mute time limit expires). In this case, one or more mute sensors must be activated while the safeguard is in the Stop state to initiate the override.

Mute Lamp Output (ML)

Depending on a risk assessment and relevant standards, some applications require that a lamp (or other means) be used to indicate when the safety device, such as a light curtain, is muted. The Safety Controller provides a signal that the protective function is suspended through the Mute status output.



Important: Mute Status Indication

Indication that the safety device is muted must be provided and be readily observable from the location of the muted safety device. Operation of the indicator may need to be verified by the operator at suitable intervals.

Muting Time Limit

The muting time limit allows the user to select a maximum period of time that muting is allowed to occur. This feature hinders the intentional defeat of the muting devices to initiate an inappropriate mute. It is also useful for detecting a common mode failure that would affect all mute devices in the application. The time limit can be adjusted from 1 second to 30 minutes, in increments of 100 milliseconds (the default is 30 s). The mute time limit may also be set to **Infinite** (disabled).

The timer begins when the second muting device meets the simultaneity requirement (within 3 seconds of the first device). After the timer expires, the mute ends despite what the signals from the mute devices indicate. If the input device being muted is in an Off state, the corresponding Muting Block output turns off.



WARNING: Muting Time Limit. Select an infinite time for the Muting Time Limit only if the possibility of an inappropriate or unintended mute cycle is minimized, as determined, and allowed by the machine's risk assessment. The user is responsible to make sure that this does not create a hazardous situation.

Mute OFF-Delay Time

A delay time may be established to extend the Mute state up to the selected time (1, 2, 3, 4, or 5 seconds) after the Mute Sensor Pair is no longer signaling a muted condition. OFF-delay is typically used for Safety Light Curtain/Grid workcell "Exit Only" applications with mute sensors located only on one side of the defined area. The Muting Block output will remain ON for up to 5 seconds after the first mute device is cleared, or until the muted Safety Input device (Mute Block In) returns to a Run state, whichever comes first.

Mute on Power-Up

This function initiates a mute cycle after power is applied to the Safety Controller. If selected, the Mute on Power-Up function initiates a mute when:

- The Mute Enable input is On (if configured)
- The safety device inputs are active (in Run mode)
- Mute sensors M1-M2 (or M3-M4, if used, but not all four) are closed

If **Auto Power-Up** is configured, the Safety Controller allows approximately 2 seconds for the input devices to become active to accommodate systems that may not be immediately active at power-up.

If **Manual Power-Up** is configured and all other conditions are satisfied, the first valid Power-Up Reset after the muted safety inputs are active (Run state or closed) will result in a mute cycle. The Mute On Power-up function should be used only if safety can be assured when the mute cycle is expected, and the use of this function is the result of a risk assessment and is required by that particular machine operation.



WARNING: The Mute on Power-Up should be used only in applications where:

- Muting the System (MP1 and MP2 closed) when power is applied is required
- Using it does not, in any situation, expose personnel to hazard

Mute Sensor Pair Debounce Times

The input debounce times, accessible under the **Advanced** settings in the **Mute Sensor Pair** properties window, may be used to extend a mute cycle after a mute sensor signal is removed. By configuring the close-to-open debounce time, the mute cycle may be extended up to 1.5 seconds (1500 ms) to allow the Safety Input Device to turn On. The start of the mute cycle can also be delayed by configuring the open-to-close debounce time.

Muting Function Requirements

The beginning and the end of a mute cycle is triggered by signals from a pair of muting devices. The muting device circuit options are configurable and shown in the Mute Sensor Pair **Properties** window. A proper mute signal occurs when both channels of the mute device change to the Mute Active states while the muted safeguard is in the Run state.

The Safety Controller monitors the mute devices to verify that their outputs turn ON within 3 seconds of each other. If the inputs do not meet this simultaneity requirement, a mute condition cannot occur.

Several types and combinations of mute devices can be used, including, but not limited to photoelectric sensors, inductive proximity sensors, limit switches, positive-driven safety switches, and whisker switches.

Corner Mirrors, Optical Safety Systems, and Muting

Mirrors are typically used with safety light curtains and single-/multiple-beam safety systems to guard multiple sides of a hazardous area.

If the safety curtain screen is muted, the safeguarding function is suspended on all sides. It must not be possible for an individual to enter the guarded area without being detected and a stop command issued to the machine control. This supplemental safeguarding is normally provided by an additional device(s) that remains active while the Primary Safeguard is muted.

Therefore, mirrors are typically not allowed for muting applications.

Multiple Presence-Sensing Safety Devices

Muting multiple presence-sensing safety devices (PSSDs) or a PSSD with multiple sensing fields is not recommended unless it is not possible for an individual to enter the guarded area without being detected and a stop command issued to the machine control.

As with the use of corner mirrors (see [Corner Mirrors, Optical Safety Systems, and Muting](#) on page 151), if multiple sensing fields are muted, the possibility exists that personnel could move through a muted area or access point to enter the safeguarded area without being detected.

For example, in an entry/exit application where a pallet initiates the mute cycle by entering a cell, if both the entry and the exit PSSDs are muted, it may be possible for an individual to access the guarded area through the “exit” of the cell. An appropriate solution would be to mute the entry and the exit with separate safeguarding devices.



WARNING:

- **Do not safeguard multiple areas with mirrors or multiple sensing fields if personnel can enter the hazardous area while the system is muted and not be detected**
- Entering the hazardous area without being detected is dangerous and could result in serious injury or death.
- Verify all areas are guarded and a stop command is issued to the guarded machine when someone enters the hazardous area.

10.6 One Shot Block

The One Shot block allows the user-configurable pulsed on state of a maximum of 5 minutes, in 1 ms increments. This feature is available on XS/SC26 FID 4 and later.

Default Nodes	Additional Nodes	Notes
IN	CD	A state change of the input signal going from low to high will trigger the output node to go high for the configured time then turn OFF.

 **Note:** The actual length of the One Shot time can be up to 1 scan time longer than the time setting.

The Cancel Delay Node is a configurable node for the One Shot block. The Cancel Delay input will immediately turn off the output node of the One Shot block after it is recognized (because of human and system delays shorter one shots will most likely end before any cancel delay can be enacted).



CAUTION: One Shot delay time effect on response time

The one shot timing may significantly increase the safety control response time. This will impact the positioning of safeguards whose installation is determined by the safety (minimum) distance formulas or are otherwise influenced by the amount of time to reach a non-hazardous state. The installation of safeguards must account for the increase in response time.

 **Note:** The response time provided on the Configuration Summary tab is a maximum time that can change depending on the use of Delay blocks, One Shot blocks, and other logic blocks (such as OR functions). The user is responsible to determine, verify, and incorporate the appropriate response time.

Figure 137. One Shot Properties



The One Shot Properties window allows the user to configure the following:

Name

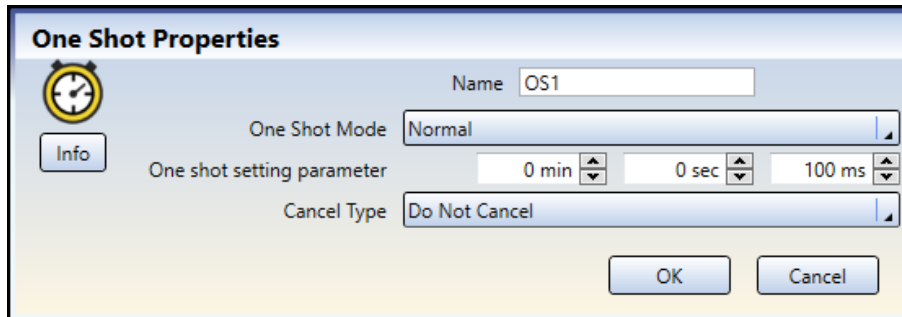
Create a name of up to 10 characters for the function block.

One Shot Mode

- Normal
- Heartbeat

One Shot Setting Parameter

One shot time: 1 ms to 5 minutes, in 1 ms increments.
The default setting is 100 ms.

Cancel Type

- Do Not Cancel
- Cancel Delay Node

One Shot Mode

When Normal mode is selected, the output node turns On when the input node turns On. The output stays on for the time set for the One Shot setting regardless of any state changes to the input. (See Figure 138 on page 152 for typical Normal One Shot timing diagrams.)

Figure 138. Typical Normal One Shot Timing Diagrams

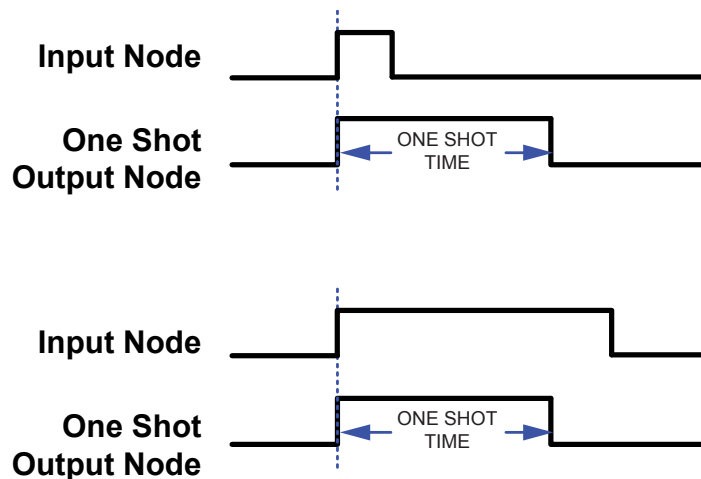

Note: The Safety Output ON time will be reduced by the turn on delay of the safety output (approximately 60 ms). The shorter the One Shot timing, the more prominent the reduction (greater percentage of the desired pulse).

When Heartbeat mode is selected, the output node turns ON when the input node turns ON. The output stays on for the time set for the One Shot setting. The timer set for the one shot will reset if the input node turns Off then back ON. (See Figure 139 on page 153 for a typical Heartbeat One Shot timing diagram.)

Figure 139. Heartbeat One Shot Timing Diagram

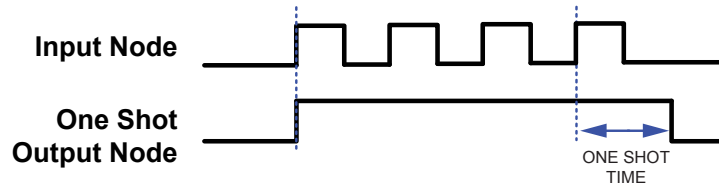

10.7 Press Control

The Press Control function block is designed for use with simple hydraulic/pneumatic power presses. This feature is available on XS/SC26 FID 4 and later.

The following standards apply:

- B11.2-2013, Safety Requirements for Hydraulic and Pneumatic Power Presses
- EN ISO 16092-1:2018, Machine Tool Safety Part 1 - General Safety Requirements
- EN ISO 16092-3, Machine Tool Safety Part 3 - Safety Requirements for Hydraulic Presses
- EN ISO 16092-4, General Safety Requirements Part 4 - Safety Requirements for Pneumatic Presses

The user has the sole responsibility to ensure their application complies with these and any other appropriate standards (including other press standards).



WARNING:

- The Press Control function block includes a starting device (initiates hazardous motion).
- Failure to follow these instructions could result in serious injury or death.
- The Qualified individual must ensure that activation (going to the ON condition) of a stopped safety device (E-stop, rope pull, optical sensor, safety mat, protective stop, etc.) by a user does not initiate hazardous motion when interfaced with a Press Control function block that is already activated (ON condition).



WARNING:

- Properly install this device.
- The user has the sole responsibility to ensure that this Banner Engineering device is installed and interfaced to the guarded machine by Qualified Persons, in accordance with this manual and applicable safety regulations. Failure to follow these instructions could result in serious injury or death.
- If all mounting, installation, interfacing, and checkout procedures are not followed properly, the Banner Engineering device cannot provide the protection for which it was designed. The user is responsible for ensuring that all local, state, and national laws, rules, codes or regulations relating to the installation and use of this control system in any particular application are satisfied. Ensure that all legal requirements have been met and that all technical installation and maintenance instructions contained in this manual are followed.

Default Nodes	Additional Nodes	Notes
GO TOS BOS RST NM Safety	Mode PCI	When selecting the Mode or PCI (Press Control Input) inputs, each generates its own function block of inputs connected to the Press Control function block. For additional information, see Mode Function Block on page 154 and Press Control Inputs Function Block on page 155.

The Press Control function block includes attributes that can be enabled or disabled.

Figure 140. Press Control Properties

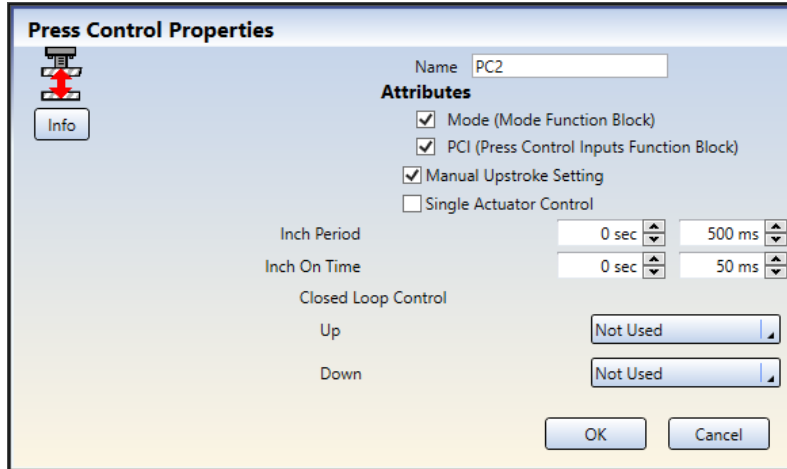

The additional nodes that can be added to the Press Control function block generate new function blocks of their own. The Mode Function Block is added if the Mode attribute is selected. The Press Control Inputs Function Block is added if the PCI attribute box is selected. The other two attributes, Manual Upstroke Setting and Single Actuator Control cannot both be selected.

When Manual Upstroke Setting is configured, the GO input must be maintained ON during the entire cycle (both down and up). The GO input node can only have a Two-Hand Control input or a Foot Switch input connected to it.

When the Single Actuator Control is configured, the GO input acts like a start button so only needs to be maintained on long enough to start the process. The GO input node can only have a Cycle Initiation input, a Foot Switch input or a Two-Hand Control input connected to it.



WARNING:

- Press upstroke hazard considerations.
- If a hazard exists during the upstroke, not using the Manual Upstroke Setting could result in serious injury or death.
- For Single Actuator Control, the upstroke of the press must not present any hazards because the mutable safety stop input is muted during the upstroke.

The other feature in the Press Control function block is **Closed Loop Control**. Enabling **Closed Loop Control** forces the controller to verify that the devices connected to the noted outputs have turned off when signaled to turn off, before then next output can turn on. For additional information, see [Closed Loop Control](#) on page 158.

10.7.1 Mode Function Block

The Mode Function Block is added if the Mode attribute is selected in the **Press Control Properties**.

The Mode Function Block selection allows the ability to add a function selector switch. The three inputs to the Press Function Block are Run, Inch Up, and Inch Down.



Note: Per the press Standards, the mode selection switch (or menu) should have these three positions and an Off position, at a minimum. The off position would not be a safety Off state, but a press in a non-run state input (does not get connected to the controller, but would also have the three Mode inputs in the Off state). If all 3 mode inputs are inactive/off, then the Press Mode FB remains Off (red).

Figure 141. Press Control Function Block Inputs

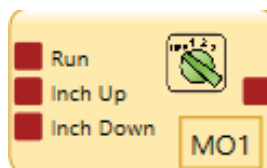

When the Mode Function Block is selected in the Press Control function block, the Inch Period and Inch On Time are added to the Press Control function block. These parameters are user-defined values for their system to ensure that the press does not move too fast when inching (typically used during setup modes).

Note: EN ISO 16092-3:2018 specifies the inch speed cannot be faster than 10 mm/second during inch mode.

- An Inch process is an intermittent motion of the slide to slowly move it up or down, typically for maintenance or die-setting
- The **Inch Period** is the complete cycle time, On and Off, of one intermittent movement of the slide
- The **Inch On Time** is the On portion of the Inch Period (the turning On of the output period to drive the slide movement)
- In setting the period and on times, take into considerations delays in the initiation of movement and the stopping of the movement to ensure proper inch speed if the GO input is held closed for multiple Inch Periods



WARNING:

- Speed of the press during Inch Mode.
- Excessive speed of the slide during inch mode could result in serious injury or death.
- Care must be taken in the setting of the Inch Period and Inch On Time to ensure the slide moves at a safe speed during inch mode.

10.7.2 Press Control Inputs Function Block

The Press Control Inputs Function Block is added if the PCI attribute box is selected in the **Press Control Properties**. When the PCI Function Block is selected, other press control attributes can be enabled.

Figure 142. Press Control Inputs Properties

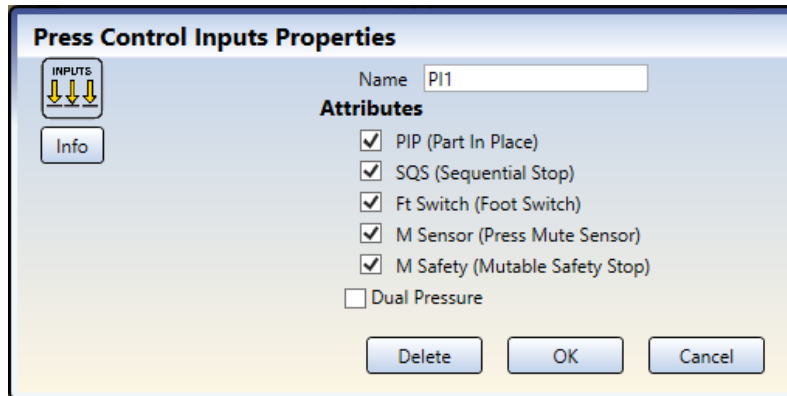

The default nodes of the PCI block are the **PIP** (Part in Place) input, **SQS** (Sequential Stop) input, and the **M Safety** (Mutable Safety Stop) input. Audience=BannerIf **SQS** is selected, the **Ft Switch** (Foot Switch) and **M Sensor** (Press Mute Sensor) inputs are available as options and the Dual Pressure attribute becomes available (this allows the addition of high and low pressure outputs to be added to the standard up and down outputs).

Use the PIP input in press controls where the press should not run if no part is present. The PIP input must be high for the press cycle to start. After the press leaves BOS, the PIP input must go low, then back to high, before the next press cycle can be initiated; this can happen before or after the press reaches TOS.

Use the SQS input in press controls where the press slide is lowered to a finger-safe point. At this point, the Mutable Safety Stop input can be muted, the operator can release the Two-Hand control input (TC1) (configured to the GO input of the Press Control function block) and can grasp the workpiece, if required. Initiating the Ft Switch (FS1) input will drive the press slide to the bottom of the stroke, where it will stop.

Note: The above is one method of controlling the Press Control process with SQS configured. There are three allowable processes:

1. TC1 turns on the GO input to drive the ram to the SQS point. Release TC1 and engage the FS1 to turn on the Ft Switch input to drive the ram to the BOS, release FS1 and engage TC1 to raise the ram.
2. FS1 turns on the GO input to drive the ram to the SQS point. Release FS1. Re-engaging FS1 drives the ram to the BOS point, and then back up to the TOS point. (The Ft Switch input will disappear when FS1 is connected to the GO node).
3. TC1 turns on the GO input to drive the ram to the SQS point, release TC1. Re-engaging TC1 drives the ram to the BOS point, and then back up to the TOS point. (To set the system up for this method, do NOT select the Ft Switch node in the Press Control Inputs Function Block.)

The M Sensor input can be used in conjunction with the SQS input to mute the Mutable Safety Stop input when it reaches a finger-safe position.

When the SQS input and Dual Pressure are configured in the Press Control Input function block, two new outputs are added to the Press Control function block. **H** (high) and **L** (low) output nodes are added in addition to the standard **U** (for Up, disengage, or return stroke) and **D** (for Down, engage, or out stroke) outputs. The H is to engage the high pressure to finish the last portion of the stroke. The L is to engage the standard (low) pressure to bring the slide down to the SQS point and to return the slide to the home position.

Figure 143. Press Control Input Block

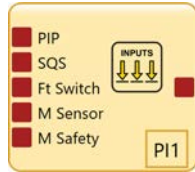
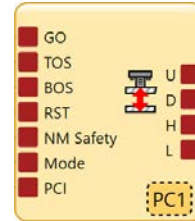

Figure 144. Press Control Function Block



10.7.3 Press Control Function Block Examples

This section includes two example configurations.

The following is an example of a simple configuration for a small press.

Figure 145. Sample Configuration for a Small Press

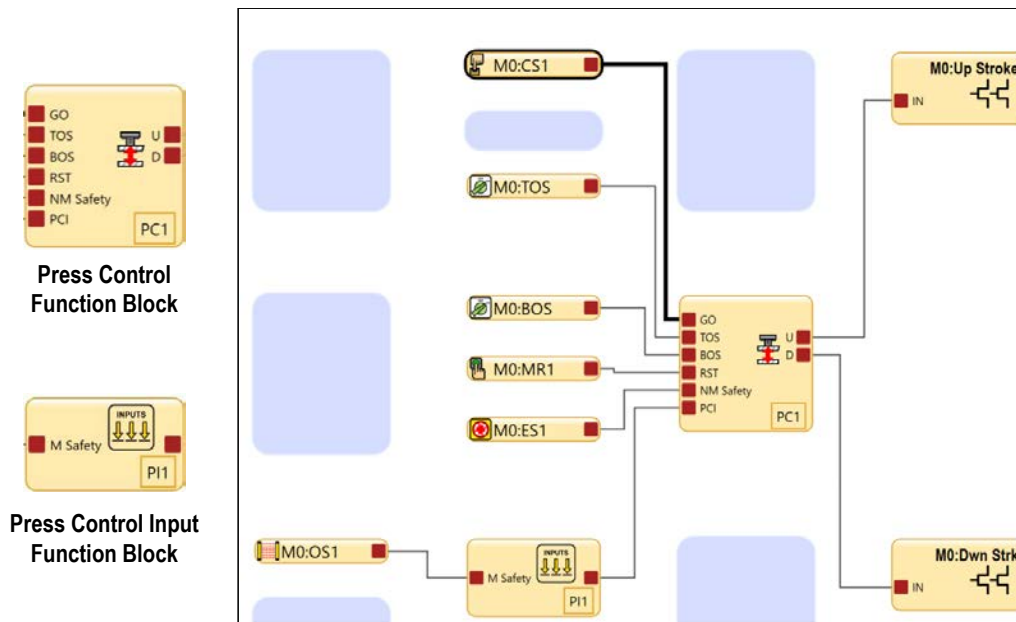

The Press Control function block requires the correct sequencing of the input signals for proper operation. ES1, OS1, and TOS must be in the Run state (and have been reset) before the CS1 input can turn on the appropriate output. This configuration is using Single Actuator Control so once the CS1 input has started the process, either the ES1 input, OS1 input or the end of the cycle (TOS turning back on) has turn OFF authority. See the timing chart below or the simulation description in [XS/SC26: Simple Press Control with Mutable Safety Input Sample Configuration](#) on page 94.

The following timing diagram shows the proper sequencing of the inputs to the Press Control function block resulting in the proper operation of the outputs when Single Actuator Control is enabled.

Figure 146. Press Control—Timing Diagram, Single Actuator Control

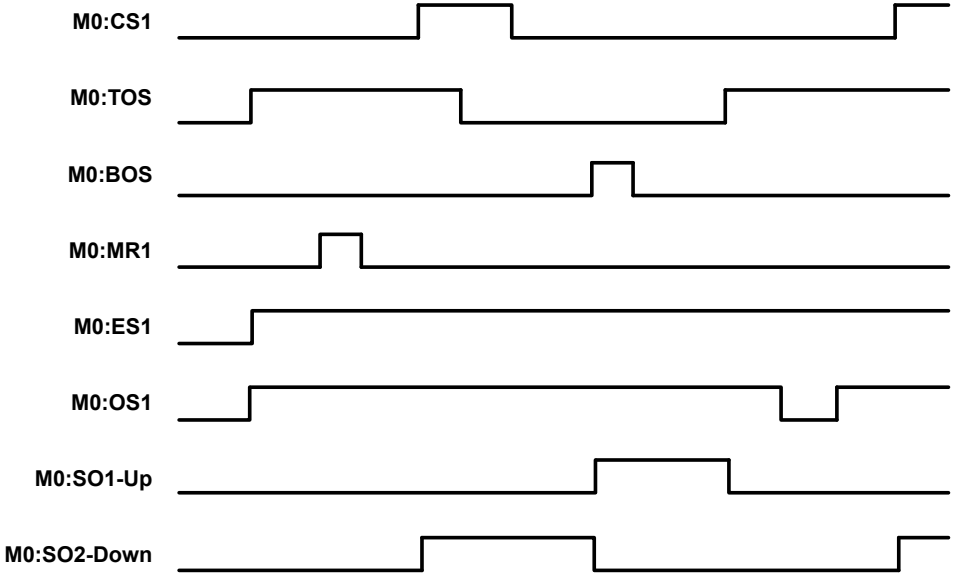

The following is a configuration using most of the features of the Press Control function block.

Figure 147. Press Control—Sample Configuration

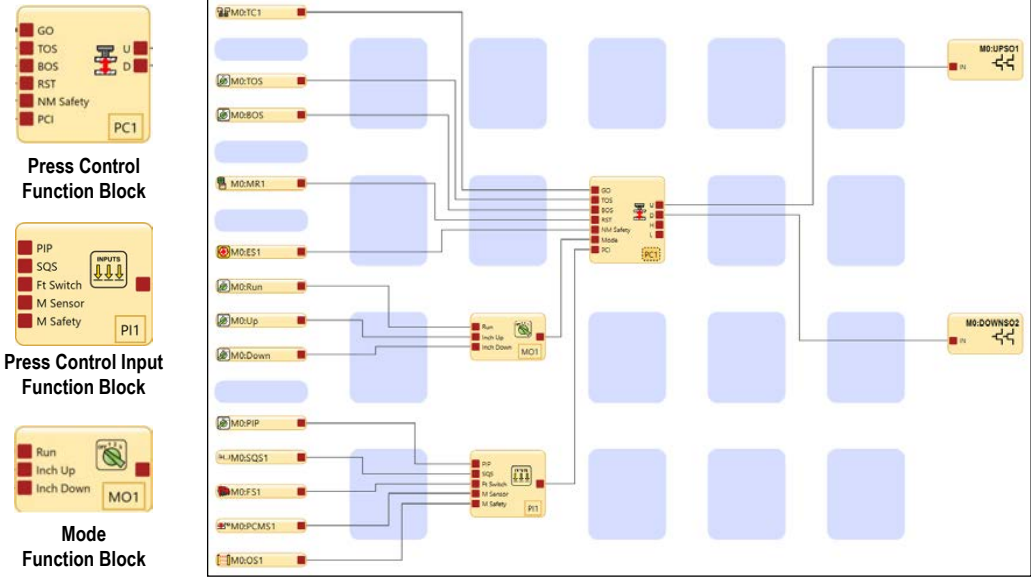

The Press Control function block requires the correct sequencing of the input signals for proper operation. This configuration uses the Manual Upstroke Setting. ES1, OS1, PIP, and TOS must be in the Run state (and have been reset) before the TC1 input can turn on the appropriate output. During the down stroke, the TC1 input starts the process, and the ES1 input, OS1 input, TC1 input or reaching the sequential stop input (SQS turns on) has turn OFF authority. When the press reaches the SQS point (SQS and PCMS turn on), it stops and the OS1 mutes. The TC1 can be released. To finish the stroke, turn on the FS1 input. During the rest of the down stroke, ES1 input, FS1 input, or the BOS (turning on) has turn OFF authority. When BOS is reached, the FS1 is released and TC1 is used to return the Press to the TOS position. During the upstroke, TC1 input, ES1 input, OS1 input, or reaching the TOS position have turn OFF authority. See the timing chart below or the simulation description in [XS/SC26: Full Feature Press Control Sample Configuration](#) on page 97.

The following timing diagram shows the proper sequencing of the inputs to the Press Control function block, resulting in the proper operation of the outputs when Manual Upstroke Setting is enabled.

Figure 148. Press Control—Timing Diagram with Manual Upstroke Setting

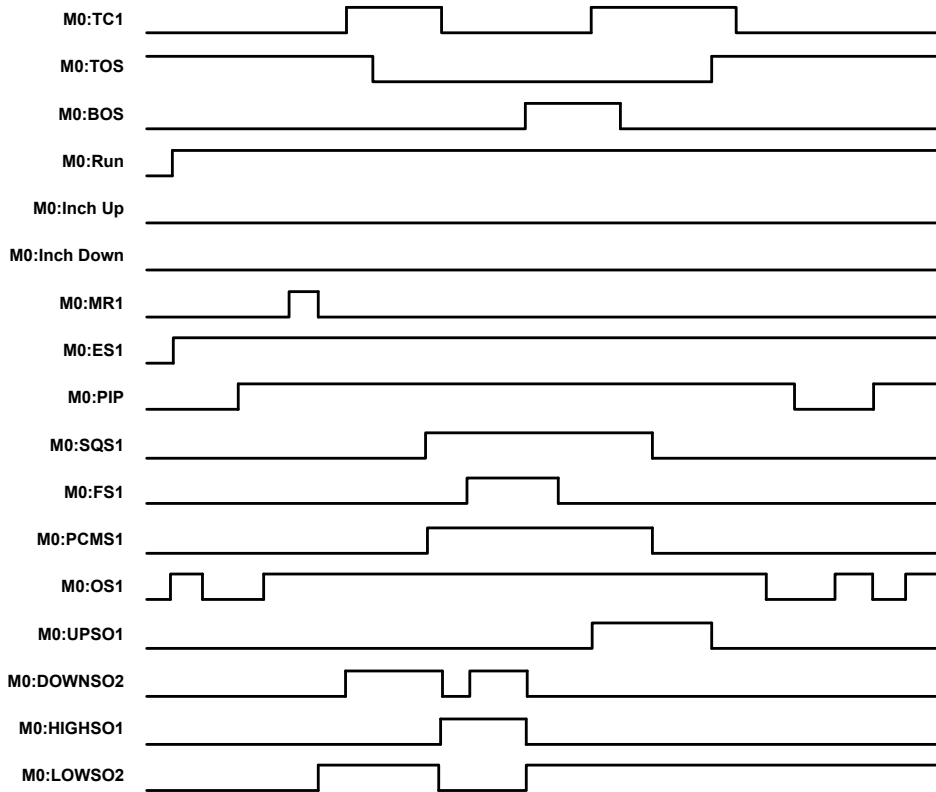

10.7.4 Closed Loop Control

The Press Control function block includes the ability to enable Closed Loop Control.

Enabling Closed Loop Control forces the controller to verify that the devices connected to the noted outputs have turned off when signaled to turn off, before enabling the next output to turn on.

To use Closed Loop Control:

1. An AVM node must be added to the desired safety output driven by the Press Control function block.
2. The AVM Input provides an indication of the state of that Press valve.
3. The Press Control function block must be configured for Closed Loop Control on a per output basis. See the **Press Control Properties** in the following figure.

Figure 149. Closed Loop Control

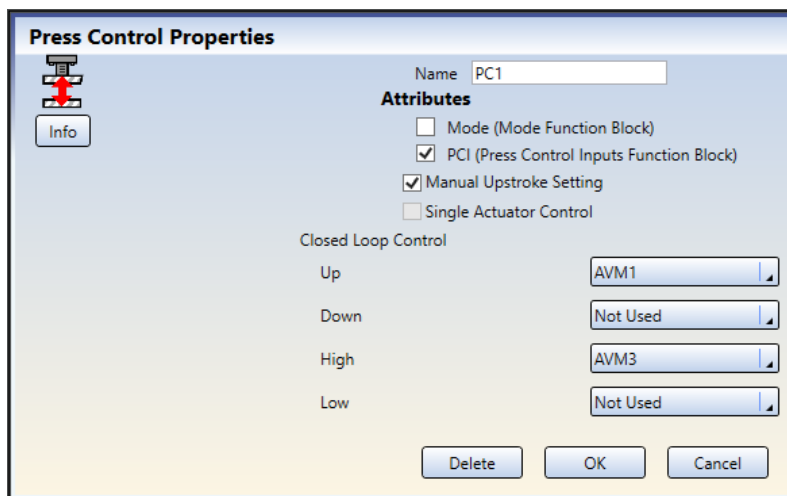

In this example the Closed Loop Control is set up to ensure the Up output valve has turned off before it will allow any other functions. It also ensures that the High valve has closed before engaging the Up output.

10.8 Two-Hand Control Block (For XS/SC26 FID 3 and older and SC10-2 FID 1)

Figure 150. Timing Diagram—Two-Hand Control Block

Default Nodes	Additional Nodes	Notes
TC (up to 4 TC nodes)	IN MP1 ME	Two-Hand Control inputs must connect either directly to a Two-Hand Control Block or indirectly through a Bypass Block connected to a Two-Hand Control Block. It is not possible to use a Two-Hand Control input without a Two-Hand Control Block. Use the IN node to connect input devices that must be on before the THC can turn the outputs on.

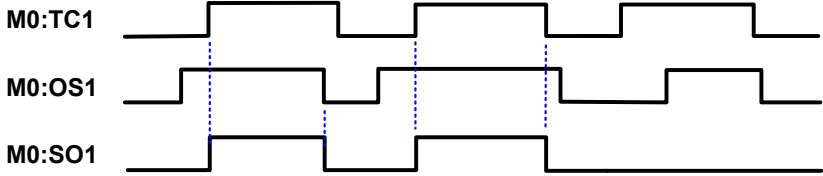
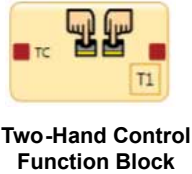

Either the TC1 input or the OS1 input has turn Off authority.
OS1 needs to be in the Run state before TC1 can turn the output of T1 & SO1 On.

Figure 151. Timing Diagram—Two-Hand Control Block and Bypass Blocks

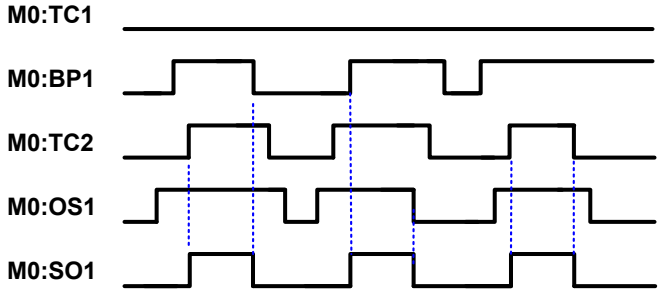
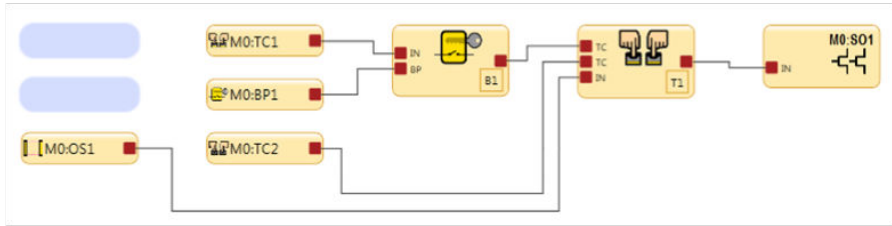
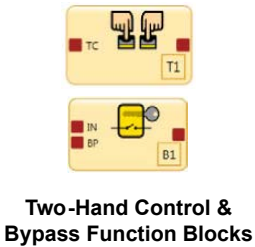

OS1 must transition to the Run state before TC2 transitions to the Run state. BP1 can transition to the Run state before or after OS1. If OS1 is in the Run state the sequence of TC2 or BP1 transition to the Run state does not matter, the last one to transition to the Run state will transition the T1 function block to the Run state.

Figure 152. Timing Diagram—Two-Hand Control Block and Bypass Blocks with One (1) Two-Hand Control Input

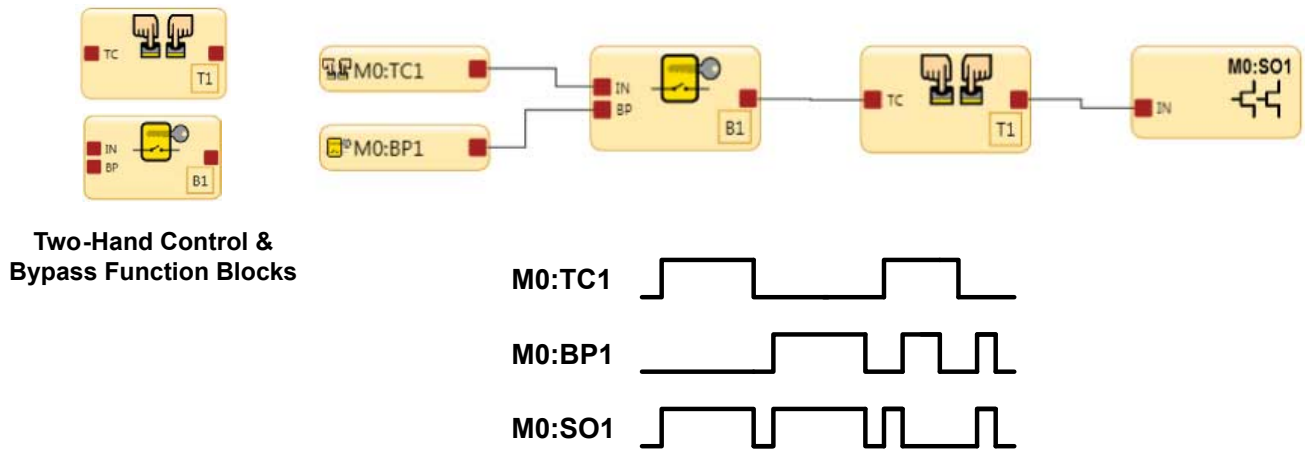

If both TC1 actuators and the BP1 Bypass switch are active at the same time, the B1 Bypass function block output and the Two-Hand Control function block output turn Off. The outputs for B1 and T1 will only turn On when either the TC1 actuators or the BP1 switch are in the Run state.

Figure 153. Timing Diagram—Two-Hand Control Block and Bypass Blocks with Two (2) Two-Hand Control Inputs

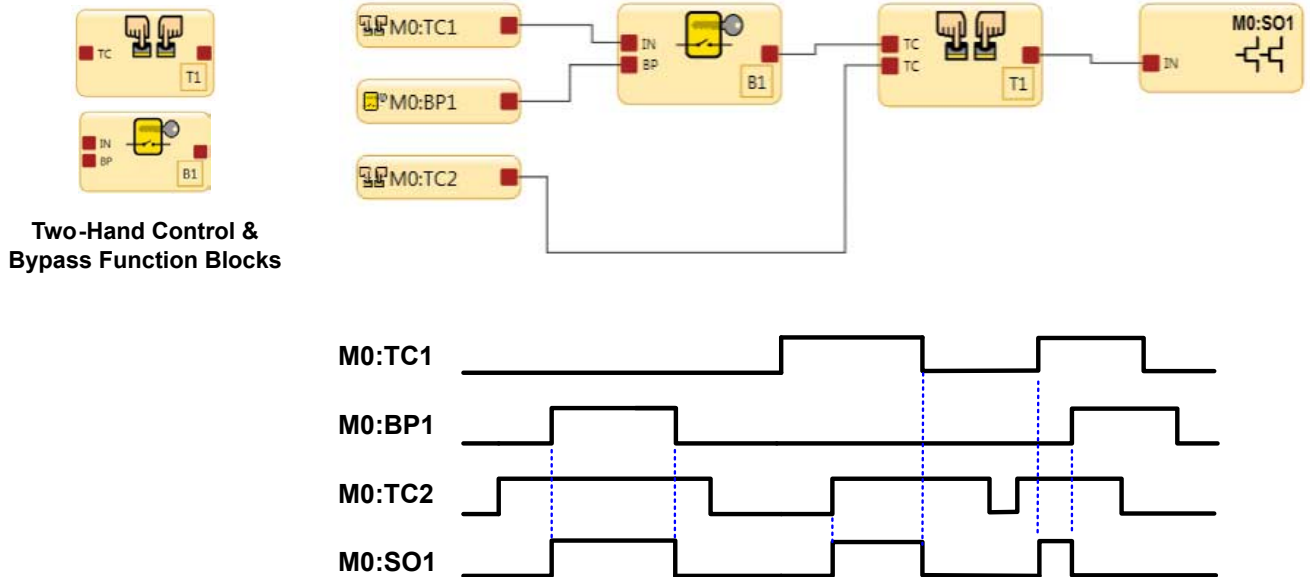

The Bypass function can be used with the TC2 actuators to turn the Safety Output On.

When the TC1 actuators are not bypassed they must be used along with the TC2 actuators to turn the Safety Output On. If the TC1 actuators and the Bypass switch are both in the Run state, T1 and SO1 cannot be turned On or will turn Off.

Figure 154. Two-Hand Control Muting Options

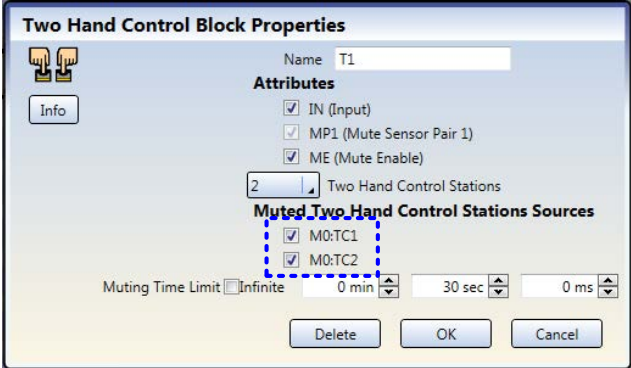

To configure the Two-Hand Control mute option, the TC actuators first need to be connected to the Two-Hand Control function block in the Function View. Check boxes (blue square above) in the Properties menu will display the names of all TC actuator input devices. Only those THx station boxes that are checked will be muted.

Figure 155. Timing Diagram—Two-Hand Control Block with Muting

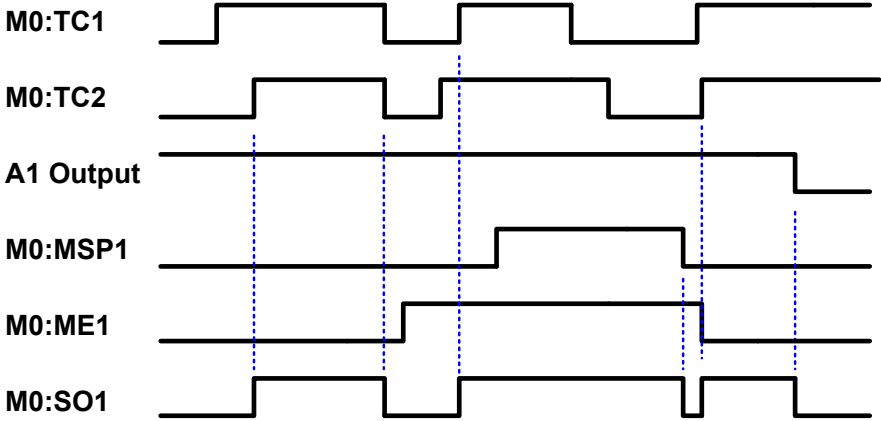
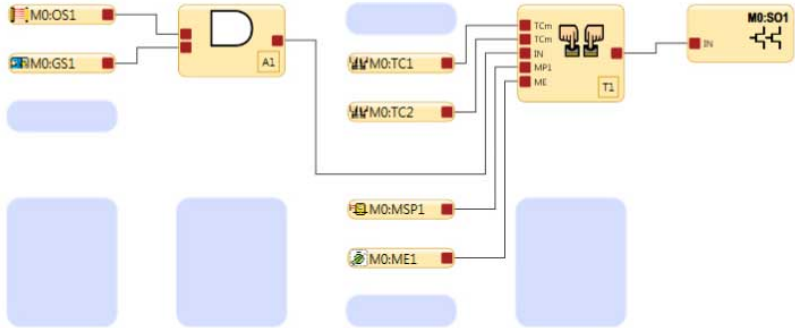
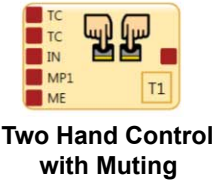

Actuators TC1 and TC2 can initiate a two-hand cycle regardless of the state of the mute enable (ME1) input (on or off). ME1 must be active for the MSP1 mute sensors to keep the SO On after the TC1 and TC2 actuators are in the Stop state.

Two-Hand Control Activation on Power-Up Protection. The Safety Controller's two-hand control logic does not permit the assigned safety output to turn On when power is initially supplied while the THC actuators are in their Run state. The THC actuators must change to their Stop state and return to the Run state before the Safety Output can turn On. A Safety Output associated with a Two-Hand Control device will not have a manual reset option.

10.9 Two-Hand Control Block (XS/SC26 FID 4 and later and SC10-2 FID 2 and later)

In XS/SC26 FID 4 and later and SC10-2 FID 2 and later devices, the TC input can be mapped directly to an output or to a logic block. The Two-Hand Control function block can be mapped directly to an output or to a logic block.

If the machine has multiple operators and each operator must actuate their two-hand controls, use the Two-Hand Control function block in which multiple TC inputs can be selected.

If the system has a hold function (TC inputs causing an action that makes it safe, then the operators can remove their hands while the process finishes), use the Two-Hand Control function block with the Muting function selected.

If the machine has certain safety devices that should be satisfied (and must stay satisfied) for the TC input to make the machine operate, use the Two-Hand Control function block with the IN node selected.

- If the IN node is off, engaging the Two-Hand input results in no actions.
- If the Two-Hand Control function block is on and the TC block goes off, the output turns off.
- When the IN node goes back high, the output stays off until the TC inputs goes off and back high.



WARNING:

- Two-Hand Controls are starting devices (initiate hazardous motion).
- Failure to follow these instructions could result in serious injury or death.
- The Qualified Individual must ensure that activation (going to the ON condition) of a stopping safety device (E-Stop, Rope Pull, Optical Sensor, Safety Mat, Protective Stop, etc.) by a user does not initiate hazardous motion when logically connected to a TC Input or Two-Hand Control function block that is already activated (ON condition).

11 XS/SC26 Onboard Interface

With the exception of special settings, the XS/SC26 Safety Controller onboard interface shows the System Status screen on power up.

Figure 156. Onboard Interface at Start Up

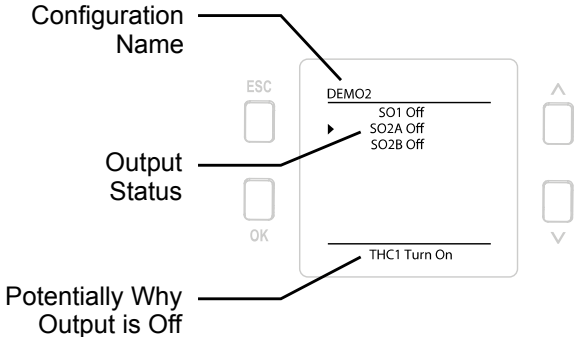

To access any other information via the onboard interface, press the escape button to access the **System Menu**.

Figure 157. Onboard Interface—System Menu

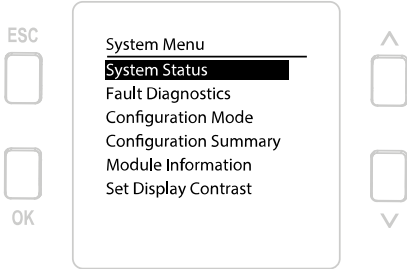

System Status

Displays the current status of Safety Outputs, and, when selected, inputs connected to that output (see [Figure 156](#) on page 163).

Fault Diagnostics

Displays the current faults, fault log, and an option to clear the fault log (see [Finding and Fixing Faults](#) on page 334).

Figure 158. Onboard Interface—Fault Diagnostics

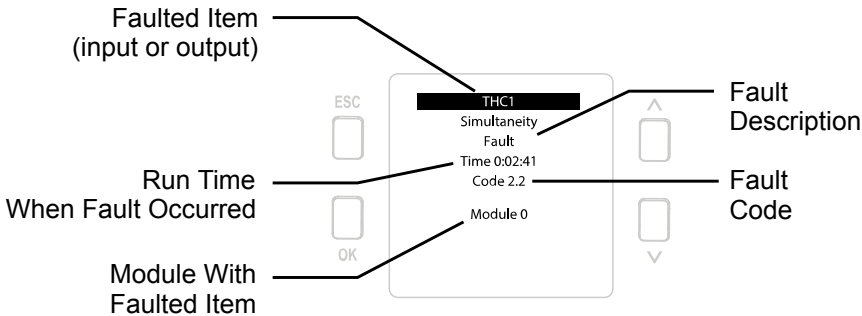

Use the arrow buttons to move to other fault codes.

Configuration Mode

Enters the Configuration Mode (password required) and provides access to copy or write the configuration from and to the SC-XM2/3 drive (see [XS/SC26 Configuration Mode](#) on page 164).

Configuration Summary

Provides the access to terminal assignments, network settings, and configuration CRC.

Model #

Displays the current model number and versions of each micro.

Figure 159. Onboard Interface—Model #

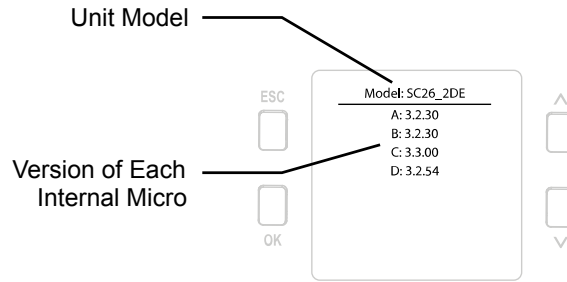

If expansion modules are attached to the Safety Controller, use the arrow buttons to view the expansion module versions.

Set Display Contrast

Provides the controls to adjust the display brightness.

Figure 160. Onboard Interface Map

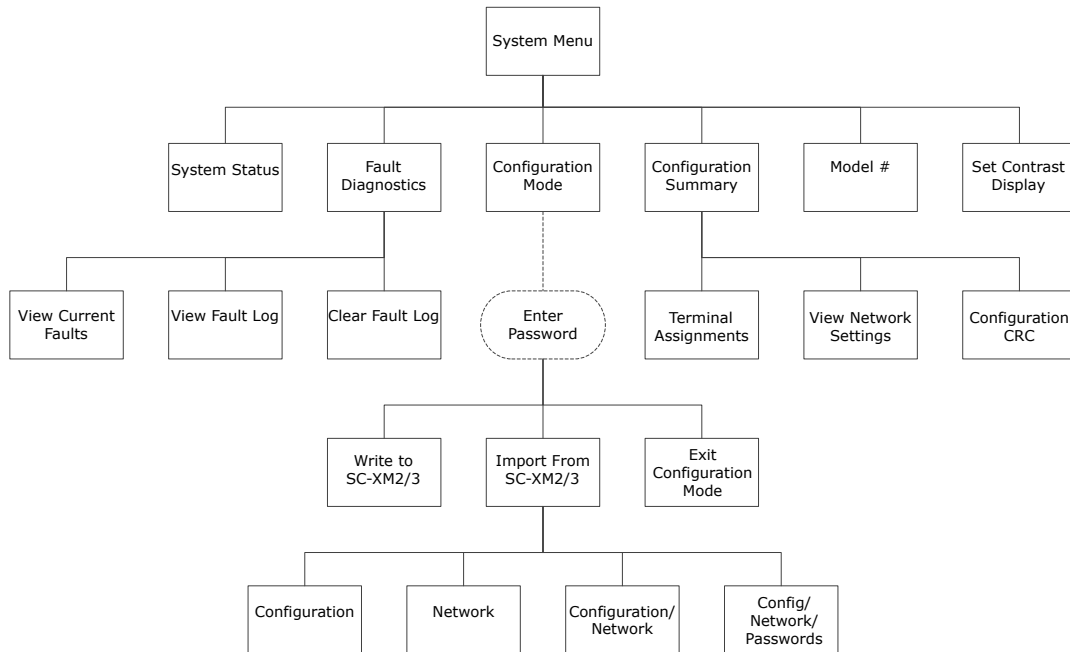

11.1 XS/SC26 Configuration Mode

Configuration Mode provides options to send the current configuration to an SC-XM2/3 drive and to receive a configuration from the SC-XM2/3 drive.



Note: A password is required to access the **Configuration Mode** menu.



Important: Entering the **Configuration Mode** turns Off Safety Outputs.

To *write* data to the SC-XM2/3 drive using the onboard interface:

1. Insert the SC-XM2/3 drive into the Safety Controller.
2. From the **System Menu**, select **Configuration Mode**.

3. Enter the password.
4. Hold **OK** until the **Configuration Mode** menu appears.
5. Select **Write to XM**.



Note: The writing to XM process copies all data (configuration, network settings, and passwords) to the SC-XM2/3 drive.

6. Wait for the write process to complete.
7. Reset the System.

To *import* data from the SC-XM2/3 drive using the onboard interface:

1. Insert the SC-XM2/3 drive into the Safety Controller.
2. From the **System Menu**, select **Configuration Mode**.
3. Enter the password.
4. Hold **OK** until the **Configuration Mode** menu appears.
5. Select **Import from XM**:
 - For configuration only, select **Configuration**
 - For network settings only, select **Network Settings**
 - For configuration and network settings, select **Configuration/Network**
 - For all data, which includes configuration, network settings, and user passwords, select **Config/Network/Passwords**
6. Wait for the import process to complete.
7. Reset the System.

12 Industrial Ethernet Overview

An aid for use in establishing Ethernet communications between the Safety Controller and a PLC or HMI.

The following sections include the instructions for Safety Controllers with the FID 2 designation on the label and date codes of 1717 or later, and for FID 3 or later Safety Controllers.

For FID 2 Safety Controllers with date codes of 1716 or earlier, see *XS26/SC26-2E (FID2 1716-) Industrial Ethernet User's Guide*. For FID 1 controllers with date codes of 1547 or later, see *XS/SC26-2E (FID 1) Industrial Ethernet User's Guide*. For older versions of FID 1 Safety Controllers, see *XS/SC26-2E (OLD) Industrial Ethernet User's Guide*. For information on where to find these documents, see [Which XS/SC26 EDS file and documentation should you use?](#) on page 174.

For PROFINET® connections on SC10-2 controllers and FID 2 or later XS/SC26 controllers, see [PROFINET](#) on page 259.

For EtherCAT® connections on FID 6 or later XS26 controllers, see [EtherCAT](#) on page 286.

12.1 Configuring the Safety Controller

Make sure that **Enable Network Interface** is selected and the network settings are configured as needed by the chosen protocol.

1. Connect the Safety Controller to your PC via the SC-USB2 USB cable to enable the port.
2. Open the Banner Safety Controller Software.
3. Click  **Network Settings**.
4. Select the **Enable Network Interface** checkbox.
5. Configure the IP Address and Subnet Mask as needed for your network.



Note: If a Virtual Reset or Cancel Delay is used, an Actuation Code must be defined and then sent to the Safety Controller.

Selecting the **Use onboard interface to set the last octet and actuation code** checkbox allows the user to set the last octet of the IP Address (and the actuation code, if needed) during the installation process. See [ClickSet IP Process](#) on page 167.

6. Click **Send**.
7. Click on the **Advanced** arrow to configure the Advanced network settings, if desired.
The following are the default values for the Safety Controller's Ethernet port and Industrial Ethernet options.

Figure 161. Default Values

Network Settings (Modbus/TCP)

Enable Network Interface

IP Address: 192 . 168 . 0 . 128

Use Onboard Interface to set the last octet and actuation code

Subnet mask: 255 . 255 . 255 . 0

Gateway address: 0 . 0 . 0 . 0

Link speed and duplex mode: Auto Negotiate

Actuation Code (Decimal 1-65535) 00000

Network Timeout Enabled

Modbus

Swap character bytes

32-bit Numerical Format

Send MSW then LSW

Send LSW then MSW

EtherNet/IP and PCCC

Swap character bytes

String Length Type

16 bits

32 bits

32-bit Numerical Format

Send MSW then LSW

Send LSW then MSW

Reset advanced settings

Basic Receive Send OK Cancel

8. Provide the appropriate password to change the configuration and network settings for the Safety Controller.
9. Make sure the Safety Controller has a valid and confirmed configuration file.

The Ethernet port is enabled.

12.1.1 ClickSet IP Process

The ClickSet IP process is available on XS/SC26 FID 5 or later controllers with an onboard interface.

Selecting the **Use onboard interface to set the last octet and actuation code** checkbox in the **Network Settings** window (and sending it to a Controller) allows the user to finalize the IP address and actuation code, if needed, during the installation process.

Selecting the **Use onboard interface to set the last octet and actuation code** checkbox forces the Subnet mask to the default setting of 255.255.255.0.

When a virtual reset or cancel delay exists, selecting the **Use onboard interface to set the last octet and actuation code** checkbox allows a temporary all-zero actuation code to be sent to the controller. The process requires the actuation code to be changed to a valid number during the installation process.

The process for setting the last Octet and the Actuation Code (if needed) is as follows:

1. Select the **Use onboard interface to set the last octet and actuation code** checkbox in the **Network Settings** window.
2. Set the other parameters (that is, the first three octets). See [Configuring the Safety Controller](#) on page 166.
3. Send the network settings to the Controller.
4. Send the desired configuration to the Controller.

When the Controller is powered on, the **Set IP Address** screen shows on the onboard interface.

Figure 162. Set IP Address Screen



Note: To leave the **Set IP Address** screen, press the ESC button. The screen changes to the **System Status** screen. To return to the **Set IP Address** screen, cycle the power.

5. To adjust the octet value, use the up or down arrow buttons to increase or decrease the octet number. If an arrow button is held down the rate of change of the numbers increases. When 1 is reached while pressing the down button, the numbers return to 254 and continue. When 254 is reached while pressing the up button, the numbers return to 1 and continue.
6. Press and hold the OK button to accept (save) the IP address.



Note: After the last octet is accepted, you cannot return to the **Set IP Address** screen. Use the Banner Safety Controller software if the IP address needs to be changed.

After the IP address is saved:

- A message displays stating that a power cycle is required to finish the process. Go to step 8.
 - The **Set Actuation code** screen displays. Go to the next step.
7. If a virtual manual reset or cancel off delay input is used in the configuration, the **Set Actuation Code** screen shows on the onboard interface after the IP Address has been saved. Use the arrow buttons to set the desired Actuation Code.

Figure 163. Set Actuation Code Screen



8. Press and hold the OK button to accept (save) the Actuation Code.



Note: After the actuation code is accepted (saved), you cannot return to the **Set Actuation Code** screen. Use the Banner Safety Controller software if the Actuation Code needs to be changed.

After the actuation code has been saved, a message displays stating that a power cycle is required to finish the process.

9. Cycle power to the Controller to internally set the new IP address and Actuation Code (if needed).

If this process is interrupted by a system lockout, the **System Status** screen opens so that the system lockout code can be checked.

If the process is interrupted (or not saved by holding the OK button), the **Set IP Address** opens the next time the controller is powered on.

12.2 Industrial Ethernet Definitions

The following are table row and column descriptions (listed in alphanumeric order) for the register maps found in the **Industrial Ethernet** tab of the Software.

Table 8: Data Types

Data Type	Description
UINT	Unsigned integer—16 bits

Data Type	Description
UDINT	Unsigned double integer—32 bits
Word	Bit string—16 bits
Dword	Bit string—32 bits
String	Two ASCII characters per Word (see protocol-based String information below)
Octet	Reads as each byte translated to decimal separated by a dot
Hex	Reads as each nibble translated to hex, paired, and then separated by a space
Byte	Bit string—8 bits

Byte:Bit

Indicates the byte offset followed by the specific bit.

Fault Flag

If the particular input or output being tracked causes a lockout, a flag associated with that virtual output will be set to 1. In Modbus TCP, this can be read as a discrete input, input register, or holding register.

Fault Index

If the Fault Flag bit is set for a virtual output, the Fault Index will contain a number, which translates to a Fault Code. For example, a Fault Index 41, can contain a number 201, which translates to the Fault Code 2.1; the number 412 would translate to the Fault Code 4.12 (see [XS/SC26 Fault Code Table](#) on page 335 and [SC10-2 Fault Code Table](#) on page 340 for more information).

Function

The function that determines the state of that virtual output.

Operating Mode

Operating Mode Value	Description
1 (0x01)	Normal Operating Mode (including I/O faults, if present)
2 (0x02)	Configuration Mode
4 (0x04)	System Lockout
65 (0x41)	Waiting For System Reset/Exiting Configuration Mode
129 (0x81)	Entering Configuration Mode

Reg:Bit

Indicates the offset from 30000 or 40000 followed by the specific bit in the register.

Reserved

Registers that are reserved for internal use.

Seconds Since boot

The time, in seconds, since power was applied to the Safety Controller. May be used in conjunction with the Timestamp in the Fault Log and a real time clock reference to establish the time when a fault occurred.

String (EtherNet/IP and PCCC Protocol)

The default format EtherNet/IP string format has a 32 bit length preceding the string (suitable for ControlLogix). When configuring the **Network Settings** using the Software, you can change this setting to a 16 bit length which corresponds to the standard CIP "String" under the **Advanced** menu. However, when reading an Input Assembly that includes a string with a 16 bit length, the string length will be preceded by an extra 16 bit word (0x0000).

The string itself is packed ASCII (2 characters per word). In some systems, the character order may appear reversed or out of order. For example, the word "System" may read out as "yStsme". Use "*Swap character bytes*" option under the **Advanced** menu in the **Network Settings** window to swap characters so words read correctly.

String (Modbus TCP Protocol)

The string format is packed ASCII (two characters per word). In some systems, the character order may appear reversed or out of order. For example, the word "System" may read out as "yStsme". Use "*Swap character bytes*" option under the **Advanced** menu in the **Network Settings** window to swap characters so words read correctly.

While the string length is provided, it is usually not required for Modbus TCP systems. If string length is used for Modbus TCP, the length format corresponds to the settings used for EtherNet/IP.

Timestamp

The time, in seconds, when the fault occurred since power up.

Virtual Status Output

The reference designator associated with a particular Virtual Status Output, for example, VO10 is Virtual Status Output 10.

VO Status

This identifies the location of a bit indicating the status of a Virtual Status Output. In the case of Modbus TCP, the state of the Virtual Status Output can be read as a discrete input, as part of an input register, or holding register. The register given is the offset from 30000 or 40000 followed by the bit location within the register.

12.3 Retrieving Current Fault Information

Follow the steps below to retrieve information via network communications about a fault that currently exists:

1. Read the *Fault Index* location to retrieve the fault index value.
2. Find the index value in the [XS/SC26 Fault Code Table](#) on page 335 or [SC10-2 Fault Code Table](#) on page 340 to access a fault description and steps to resolve the fault.

12.4 EtherNet/IP™

In this context, references to EtherNet/IP™²³ refer specifically to EtherNet/IP transport class 1. Sometimes referred to as cyclic EtherNet/IP IO data transfer or implicit messaging, this connection is meant to approximate a real-time data transfer to and from the PLC and the target device.

Allen-Bradley's CompactLogix® and ControlLogix®²⁴ family of PLCs uses this communication protocol. The programming software used by these PLCs is RSLogix5000® or Studio 5000 Logix Designer™²⁵.

There are three methods to establish an EIP connection between the PLC and the Safety Controller:

- L5X—see [L5X File Connection](#) on page 170
- EDS file (with optional CSV tag label file)—see [Banner Safety Controller EDS File Installation in ControlLogix Software](#) on page 175
- Generic Ethernet—see [Generic Ethernet Module Connection](#) on page 183

12.4.1 L5X File Connection

Create L5X Files For Ethernet/IP Assemblies

The .L5X file is an XML (eXtensible Markup Language) file that stores both EtherNet/IP connection details and tag descriptions. Exporting this file from the Safety Controller software and importing it into the RS Studio 5000 PLC software is a convenient way to make an EtherNet/IP connection between the PLC and the Safety Controller with labeled tag descriptions, all in one step.

To create the L5X file, two items must be known:

- The name assigned to the Safety Controller in the PLC. This is needed to generate the file to import into the PLC software
 - Which input and output assembly instances are going to be requested
1. On the **Industrial Ethernet** tab, make sure **Ethernet/IP Assemblies** is selected from the list at the left.
 2. Click **Export**.
The **Export to CSV & L5X** window opens.

Figure 164. Export to CSV & L5X

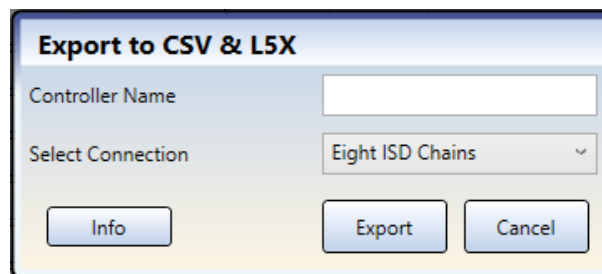

²³ EtherNet/IP™ is a trademark of ODVA, Inc.

²⁴ CompactLogix® and ControlLogix® are registered trademarks of Rockwell Automation.

²⁵ RSLogix5000® and Studio 5000 Logix Designer™ are registered trademarks of Rockwell Automation.

3. In the **Controller Name** field, enter the name assigned to the Safety Controller in the PLC software.
See [Figure 180](#) on page 179.
4. Select the desired connection in the **Select Connection** list.

Which connection to select is based on what Assembly Instances are being requested:

Table 9: **Select Connection** Field Choices

Connection Name	Output Assembly	Input Assembly
Status/Fault	112	100
Fault Index Words	112	101
Reset/Cancel Delay	112	103
VI Status/Faults	113	100
VI Fault Index Words	113	101
VI Reset/Cancel Delay	113	103
VRCD Plus ISD	114	104
Eight ISD Chains	114	105



Note: Select the same connection for the EDS file connection to ensure that the labels match. See [Figure 181](#) on page 179.

If any virtual inputs (VI) are being used, the PLC's output assembly must be set to 113 or 114. This is so that the PLC can send the virtual input words to the Safety Controller. If information on the ISD inputs is desired with XS26-ISD FID 5 or later or SC10-2 FID 2 or later controllers, an output assembly of 114 must be used to send virtual inputs (if used) and the extra words to request the ISD information (VRCD—virtual reset/cancel delay).

Input assembly 104 is used for up to two ISD chains (by either XS26-ISD FID 5 or later, if the chains are added to IN1/IN2 and IN3/IN4, or SC10-2 FID 2 or later controllers). Input assembly 105 supports up to eight ISD chains and can be used only by XS26-ISD FID 5 or later.

5. Click **Export**.
6. Save the .L5X file in the desired location.



Note: A .L5X and a .csv file are both saved.

The .L5X file can create a labeled connection all in one step. See [Create Labeled Connections using an L5X File](#) on page 171.

Create Labeled Connections using an L5X File

1. In Studio 5000[®] ²⁷, click on the Ethernet module, then click **Tools > Import > Component**.

²⁷ Studio 5000[®] is a registered trademark of Rockwell Automation.

Figure 165. Studio 5000

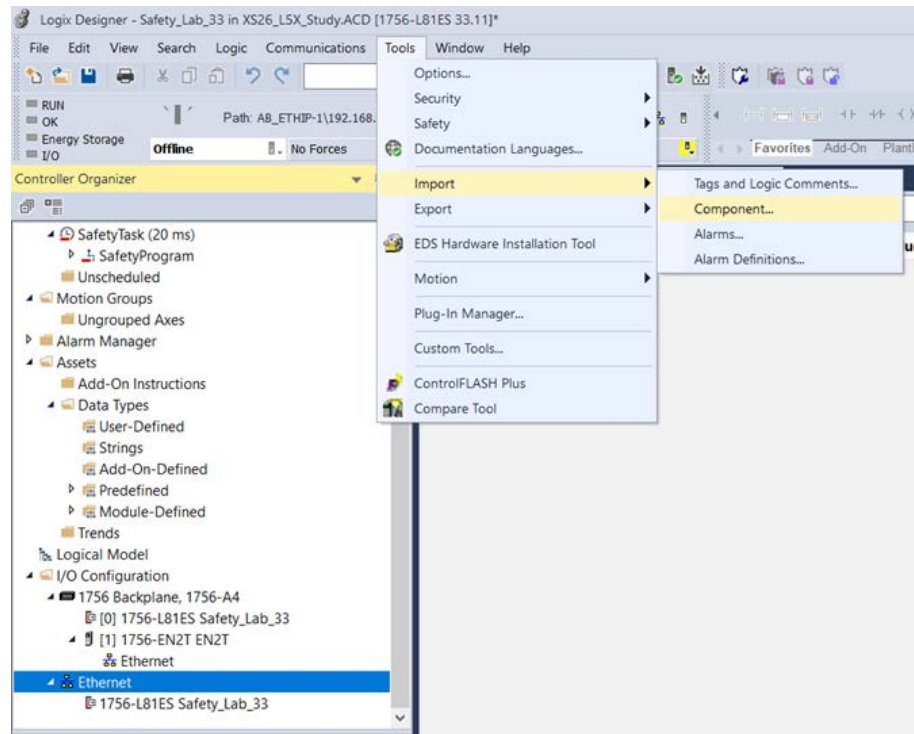

The **Import Module** window opens.

2. Browse to the folder location where the .csv and .L5X files are saved and select the .L5X file.
3. Click **Open**.
Studio 5000 imports the .L5X file.
4. After the .L5X file has been successfully imported, click **OK** to use the .L5X file to make a connection with labeled tags.

Figure 166. Import Configuration Window

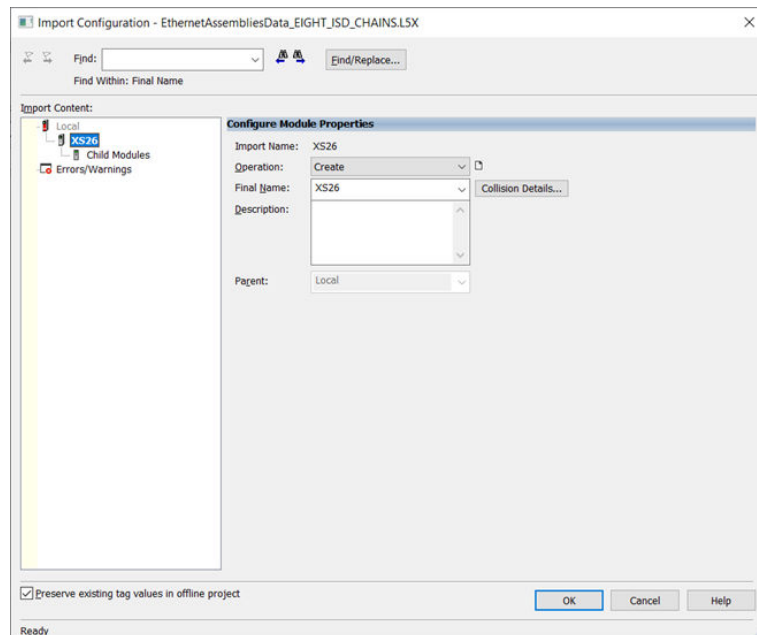

5. Download the project to the PLC.
6. Go to Run mode.

Figure 167. Run Mode

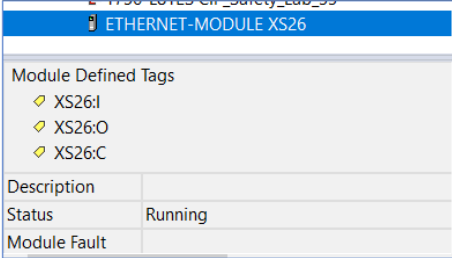

To see the PLC input data and the PLC output data, look in **Controller Tags** under the controller name provided when the .L5X file was created from the Banner Safety Controller software. The description column shows the labels specific to your safety controller configuration.

Figure 168. Controller Tags Window—PLC Input Data

Name	Value	Force Mas	Style	Data Type	Class	Description
XS26I	(-)	(-)	(-)	AB:ETHERNET_MO...	Standard	Banner SafetyController
XS26I.Data	(-)	(-)	Decimal	INT[240]	Standard	Data from SafetyController
XS26I.Data[0]	24		Decimal	INT	Standard	Status Data
XS26I.Data[0].0	0		Decimal	BOOL	Standard	System Lockout
XS26I.Data[0].1	0		Decimal	BOOL	Standard	Track Any Input Fault
XS26I.Data[0].2	0		Decimal	BOOL	Standard	Track Output Fault All
XS26I.Data[0].3	1		Decimal	BOOL	Standard	Track M0:S01
XS26I.Data[0].4	1		Decimal	BOOL	Standard	Track M0:SD1
XS26I.Data[0].5	0		Decimal	BOOL	Standard	VO6
XS26I.Data[0].6	0		Decimal	BOOL	Standard	VO7
XS26I.Data[0].7	0		Decimal	BOOL	Standard	VO8
XS26I.Data[0].8	0		Decimal	BOOL	Standard	VO9
XS26I.Data[0].9	0		Decimal	BOOL	Standard	VO10
XS26I.Data[0].10	0		Decimal	BOOL	Standard	VO11
XS26I.Data[0].11	0		Decimal	BOOL	Standard	VO12
XS26I.Data[0].12	0		Decimal	BOOL	Standard	VO13
XS26I.Data[0].13	0		Decimal	BOOL	Standard	VO14

Figure 169. Controller Tags Window—PLC Output Data

Name	Value	Force Mas	Style	Data Type	Class	Description
XS26O	(-)	(-)	(-)	AB:ETHERNET_MO...	Standard	Banner SafetyController
XS26O.Data	(-)	(-)	Decimal	INT[14]	Standard	Data from SafetyController
XS26O.Data[0]	0		Decimal	INT	Standard	Control Data
XS26O.Data[0].0	0		Decimal	BOOL	Standard	Virtual Input1 On/Off
XS26O.Data[0].1	0		Decimal	BOOL	Standard	Virtual Input2 On/Off
XS26O.Data[0].2	0		Decimal	BOOL	Standard	Virtual Input3 On/Off
XS26O.Data[0].3	0		Decimal	BOOL	Standard	Virtual Input4 On/Off
XS26O.Data[0].4	0		Decimal	BOOL	Standard	Virtual Input5 On/Off
XS26O.Data[0].5	0		Decimal	BOOL	Standard	Virtual Input6 On/Off
XS26O.Data[0].6	0		Decimal	BOOL	Standard	Virtual Input7 On/Off
XS26O.Data[0].7	0		Decimal	BOOL	Standard	Virtual Input8 On/Off
XS26O.Data[0].8	0		Decimal	BOOL	Standard	Virtual Input9 On/Off
XS26O.Data[0].9	0		Decimal	BOOL	Standard	Virtual Input10 On/Off
XS26O.Data[0].10	0		Decimal	BOOL	Standard	Virtual Input11 On/Off
XS26O.Data[0].11	0		Decimal	BOOL	Standard	Virtual Input12 On/Off
XS26O.Data[0].12	0		Decimal	BOOL	Standard	Virtual Input13 On/Off
XS26O.Data[0].13	0		Decimal	BOOL	Standard	Virtual Input14 On/Off
XS26O.Data[0].14	0		Decimal	BOOL	Standard	Virtual Input15 On/Off
XS26O.Data[0].15	0		Decimal	BOOL	Standard	Virtual Input16 On/Off

12.4.2 EDS File Connection

Which XS/SC26 EDS file and documentation should you use?

Figure 170. FID Number

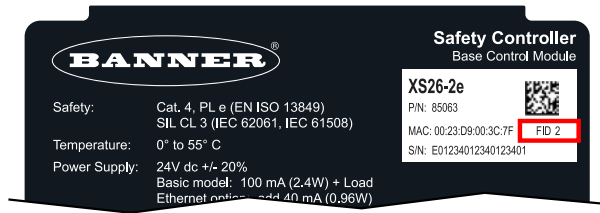
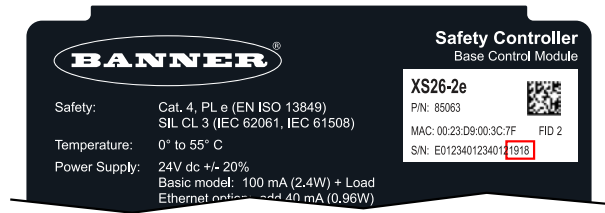

Figure 171. Serial Number



1. Check the model number label and take note of the FID number and date code.
The date code is the last 4 digits of the Safety Controller serial number. In the example shown, “19” means 2019 and “18” means 18th week.
2. Use the FID number and date code to find the correct EIP parameters, EDS file, and Industrial Ethernet User's Guide (if applicable) from the following table.

Model & FID	Date Code	EIP ProdCode	O>T — size	T>O — size	Files to Use
XS26 SC26 1	1546 or lower	8193	112 (0×70) - 2	100 (0×64) - 8 101 (0×65) - 104 102 (0×66) - 150	Product Name [Maj.Min Rev]: Banner XS26 (8193) [2.22] EDS File: BannerXS_SC26_2E_8193_1_4_08102017.eds Industrial Ethernet User's Guide: XS/SC26-2E (OLD) Industrial Ethernet User's Guide
XS26 SC26 1	1547 to 1705	300 ²⁹	112 (0×70) - 2	100 (0×64) - 8 101 (0×65) - 104 102 (0×66) - 150	Product Name [Maj.Min Rev]: Banner XS26 1547 (300) [2.002] EDS File: BannerXS_SC26_2E_300_1547_1_6_08102017.eds ²⁹ Industrial Ethernet User's Guide: XS/SC26-2E (FID 1) Industrial Ethernet User's Guide
XS26 SC26 2	1706 to 1716	301	112 (0×70) - 11	100 (0×64) - 8 101 (0×65) - 104 102 (0×66) - 150 103 (0×67) - 35	Product Name [Maj.Min Rev]: Banner XS26 FID2 (301) [2.050] EDS File: BannerXS_SC26_2E_301_FID2_1_2_08102017.eds Industrial Ethernet User's Guide: XS/SC26-2E (FID 2 1716-) Industrial Ethernet User's Guide
XS26 SC26 2 & 3	1717 or later	300 ²⁹	112 (0×70) - 2 113 (0×70) - 11	100 (0×64) - 8 101 (0×65) - 104 102 (0×66) - 150 103 (0×67) - 35	Product Name [Maj.Min Rev]: Banner XS26 FID 1/2 (300) [2.064] EDS File: BannerXS_SC26_2E_300_1_8_11102017.eds ²⁹ Industrial Ethernet User's Guide: XS/SC26-2E (FID 2 1717+) Industrial Ethernet User's Guide
XS26 SC26 2, 3 & 4 SC10 any	1717 or later	300 ²⁹	112 (0×70) - 2 113 (0×70) - 11 114 (0×72) - 14	100 (0×64) - 8 101 (0×65) - 104 102 (0×66) - 150 103 (0×67) - 35 104 (0×68) - 112	Product Name [Maj.Min Rev]: Banner XS26 SC26 SC10 (300) [2.090] EDS File: Banner_XS26_SC26_SC10_300_2_1_06022020.eds ²⁹ XS/SC26-2 and SC10-2 Instruction Manual: rev R and later

²⁹ Banner_XS26_SC26_SC10_300_2_3_05192021.eds is backwards compatible with all ProdCode 300 controllers (XS26, SC26, SC10).

Model & FID	Date Code	EIP ProdCode	O>T — size	T>O — size	Files to Use
XS26 2, 3, 4, 5 & 6 SC10 any	1717 or later	300	112 (0×70) - 2 113 (0×71) - 11 114 (0×72) - 14	100 (0×64) - 8 101 (0×65) - 104 102 (0×66) - 150 103 (0×67) - 35 104 (0×68) - 112 105 (0×69) - 240	Product Name [Maj.Min Rev]: Banner Safety Controller [2.001] EDS File: Banner_XS26_SC26_SC10_300_2_3_05192021.eds XS/SC26 and SC10-2 Instruction Manual: rev W and later



Note: As of 1 October 2019, the current Industrial Ethernet information is part of the *XS/SC26 and SC10-2 Instruction Manual*. The *Industrial Ethernet User's Guide* for the older systems is embedded in the EDS folder available at www.bannerengineering.com/safetycontroller.

Banner Safety Controller EDS File Installation in ControlLogix Software

Use the **EDS Hardware Installation Tool** to register the Electronic Data Sheet (EDS) file.

1. On the **Tools** menu, click **EDS Hardware Installation Tool**.
The **Rockwell Automation's EDS Wizard** dialog displays.

Figure 172. Tools—EDS Hardware Installation Tool

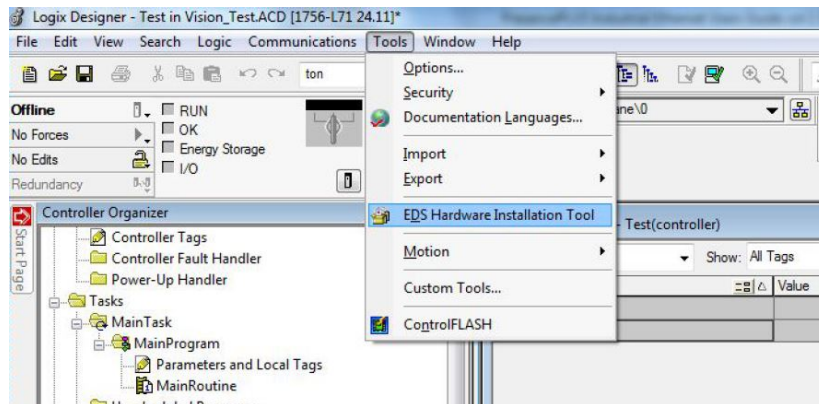

2. Click **Next**.
3. Select the **Register an EDS file(s)** option.

Figure 173. Rockwell Automation's EDS Wizard—Options



4. Browse to locate the EDS file and click **Next**.

See [Which XS/SC26 EDS file and documentation should you use?](#) on page 174 for more information.

Figure 174. Select File to Register

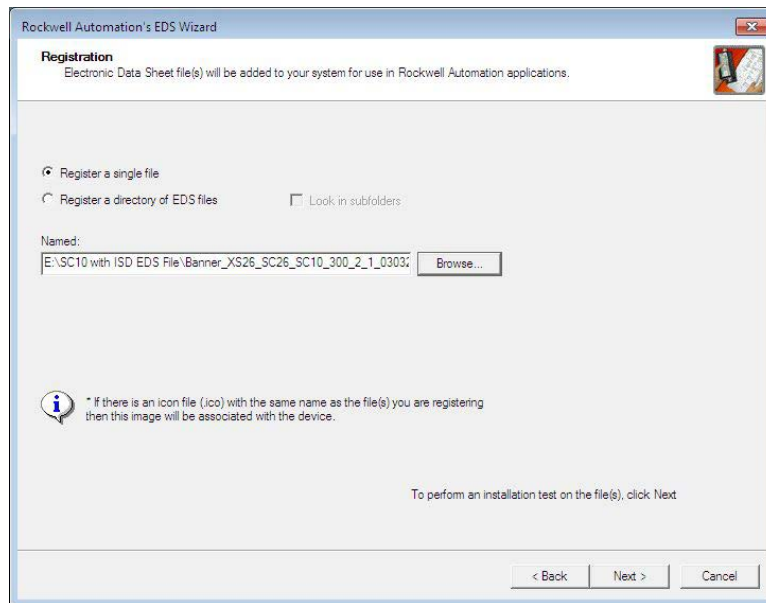

5. Click **Next** to register the tested file.

Figure 175. Register the Tested File

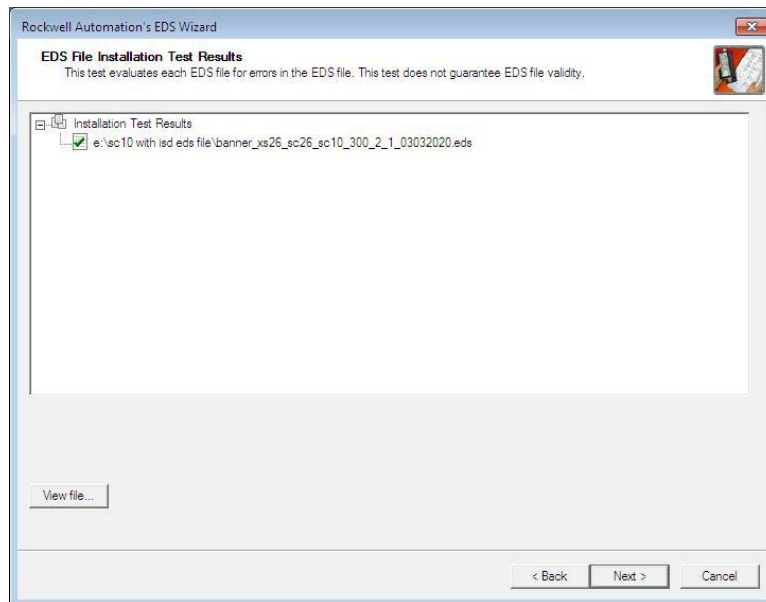

6. Click **Next** when you see the icon associated with the EDS file.

Figure 176. Rockwell Automation's EDS Wizard

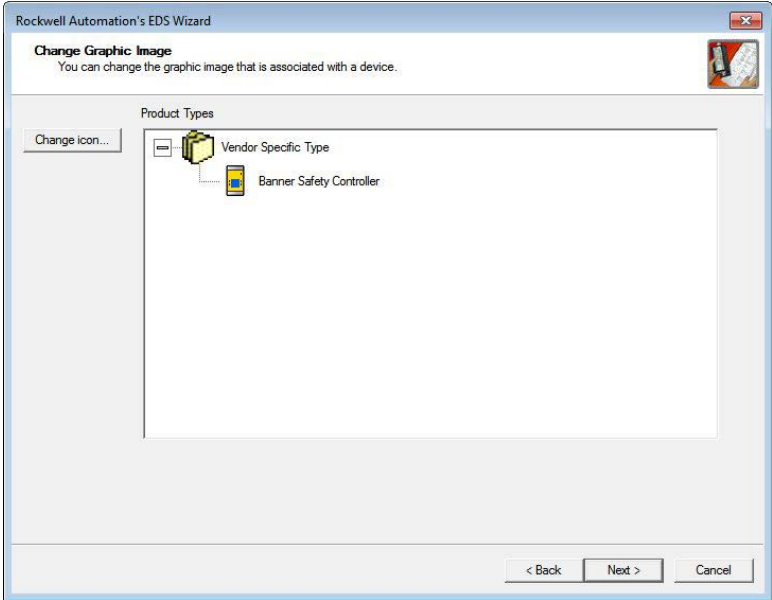

7. Click **Next** to register the EDS file.

Figure 177. Register the EDS File

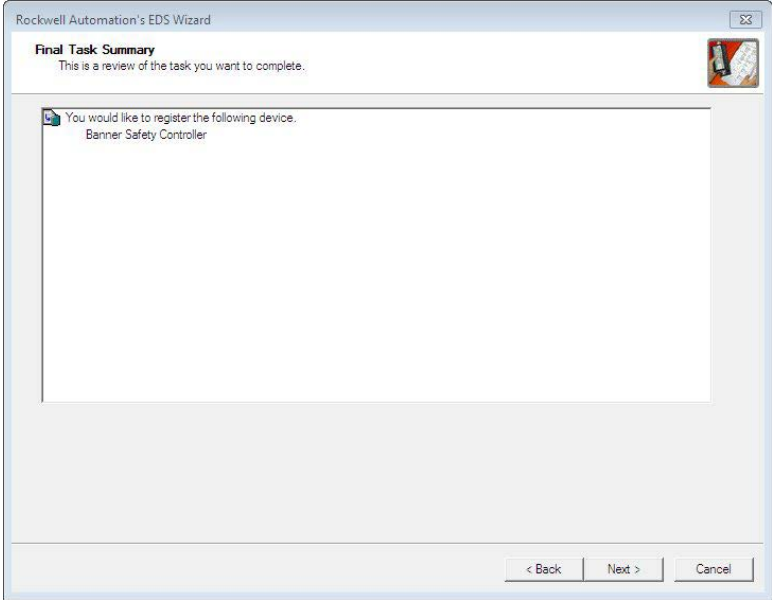

- 8. Click **Finish** to close the **EDS Wizard** .
- 9. Right-click on the PLC's Ethernet adapter and select **New Module...**

Figure 178. New Module

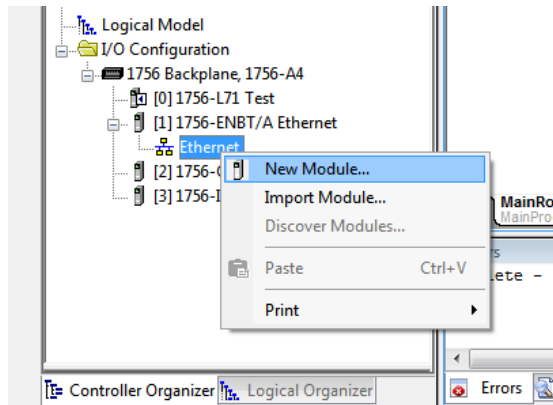

10. Locate the device in the catalog and click **Create**.

Figure 179. Select Module Type

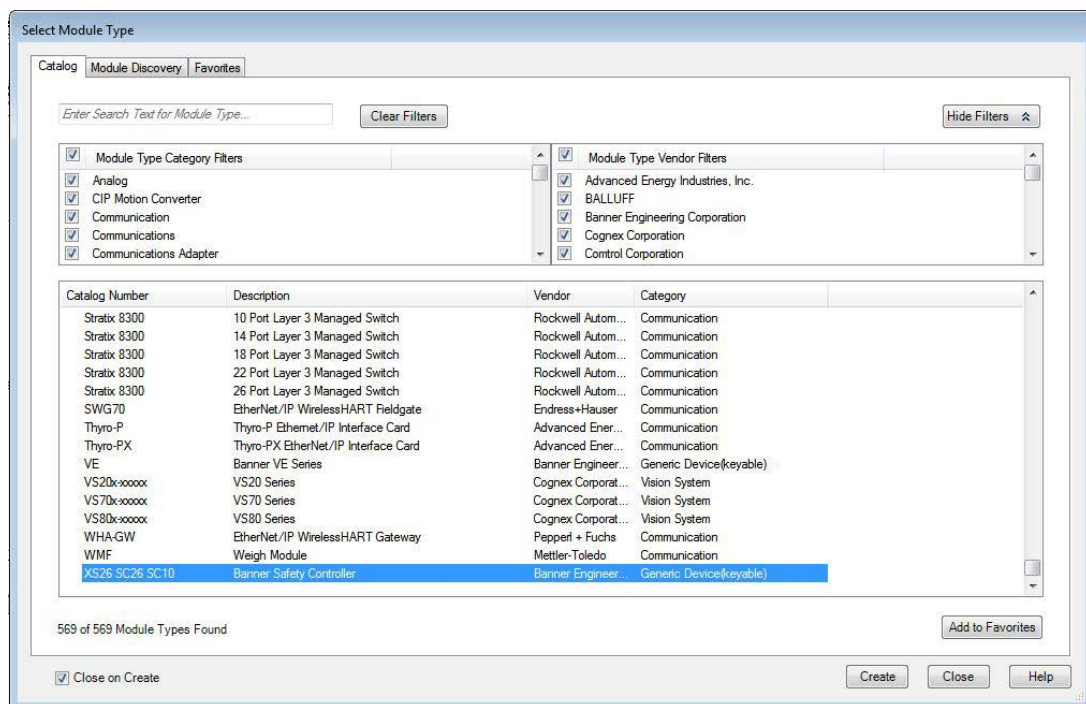

11. Enter a name, description (optional), and IP address for the device.

Figure 180. New Module

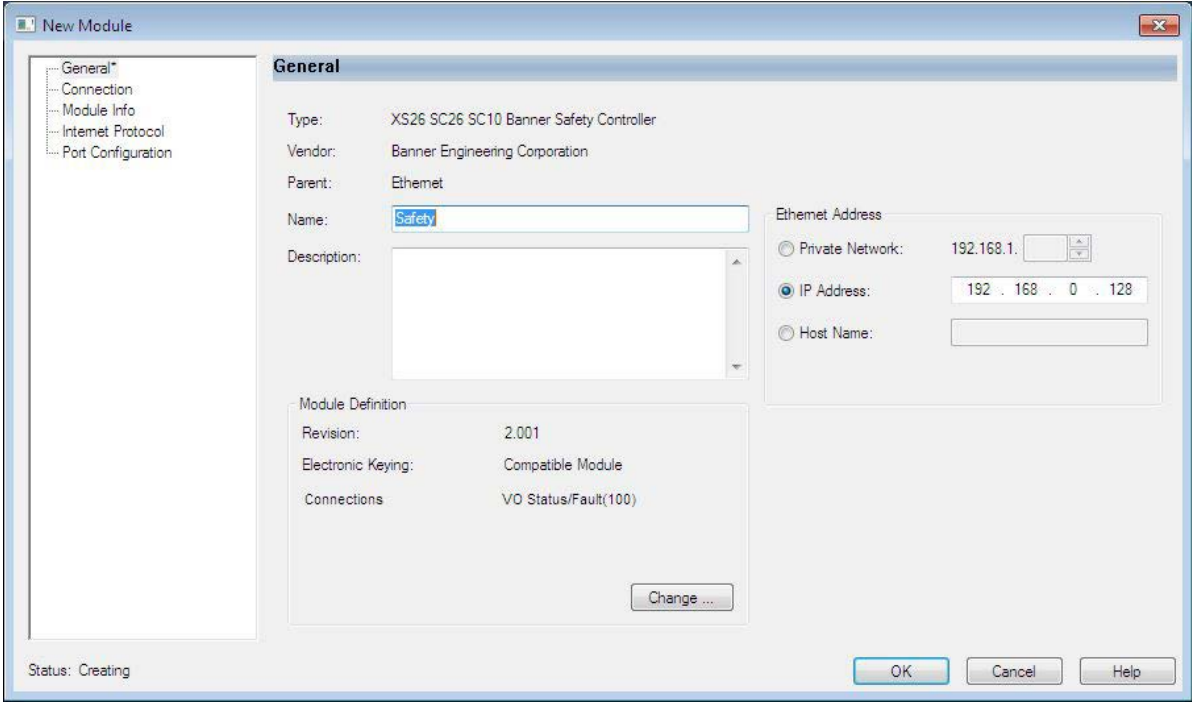

12. Click **Change** in the **Module Definition** field.

Figure 181. Module Definition

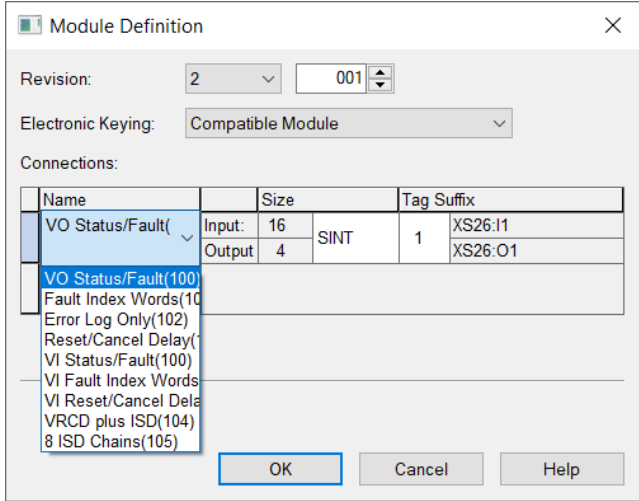

13. Select the desired connection in the **Module Definition** window. Each of the items in the **Name** list represents a fixed grouping of input and output assembly instances:



Note:

- Not all connection options are applicable to all Safety Controllers.
- Select only one **Name** from the list. Assigning multiple names causes communication issues (causes bits to turn ON and OFF).

VO Status/Fault (100)-

- O>T PLC Output/Safety Controller Input Assembly 112 (0x70), size 2 16-bit registers
- T>O PLC Input/Safety Controller Output Assembly 100 (0x64), size 8 16-bit registers

Fault Index Words (101)-

- O>T PLC Output/Safety Controller Input Assembly 112 (0x70), size 2 16-bit registers
- T>O PLC Input/Safety Controller Output Assembly 101 (0x65), size 104 16-bit registers

Error Log Only (102)-

- O>T PLC Output/Safety Controller Input Assembly 112 (0×70), size 2 16-bit registers
- T>O PLC Input/Safety Controller Output Assembly 102 (0×66), size 150 16-bit registers

Reset/Cancel Delay (103)-

- O>T PLC Output/Safety Controller Input Assembly 112 (0×70), size 2 16-bit registers
- T>O PLC Input/Safety Controller Output Assembly 103 (0×67), size 35 16-bit registers

VI Status/Fault (100)-³⁰

- O>T PLC Output/Safety Controller Input Assembly 113 (0×71), size 11 16-bit registers
- T>O PLC Input/Safety Controller Output Assembly 100 (0×64), size 8 16-bit registers

VI Fault Index Words (101)-³⁰

- O>T PLC Output/Safety Controller Input Assembly 113 (0×71), size 11 16-bit registers
- T>O PLC Input/Safety Controller Output Assembly 101 (0×65), size 104 16-bit registers

VI Reset/Cancel Delay (103)-³⁰

- O>T PLC Output/Safety Controller Input Assembly 113 (0×71), size 11 16-bit registers
- T>O PLC Input/Safety Controller Output Assembly 103 (0×67), size 35 16-bit registers

VRCD plus ISD (104)-³⁰

- O>T PLC Output/Safety Controller Input Assembly 114 (0×72), size 14 16-bit registers
- T>O PLC Input/Safety Controller Output Assembly 104 (0×68), size 112 16-bit registers

8 ISD Chains (105)-

- O>T PLC Output/Safety Controller Input Assembly 114 (0×72), size 14 16-bit registers
- T>O PLC Input/Safety Controller Output Assembly 105 (0×69), size 240 16-bit registers

14. Select **INT** as the data type.

Figure 182. Module Definition—Data Type

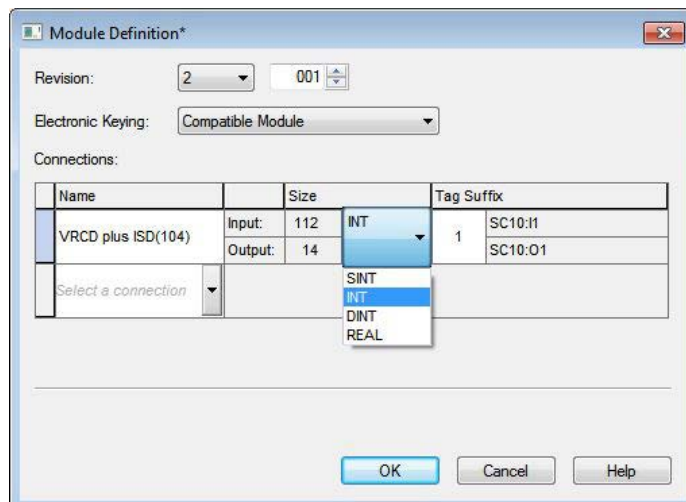

15. Optional: The Banner Safety Controller software can export a CSV file to provide description labels for the newly created tags in the PLC.

When offline in the RS Studio 5000 PLC software and there is a project open, import tag descriptions from a saved CSV file.

Select the same connection for the EDS file connection (for example, Eight ISD Chains) and in the **Export to CSV & L5X** window. This ensures that the labels from the exported CSV will match the tags created by the EDS file.

To create the CSV files, two items must be known:

- The name assigned to the Safety Controller in the PLC. This is needed to generate the file to import into the PLC software
- Which input and output assembly instances are going to be requested

³⁰ Select one of the O>T Assembly Instance 113 (0×71) or 114 (0×72) connections to use Virtual Input/Cancel Delay.

- a) In the Banner Safety Controller software, on the **Industrial Ethernet** tab, make sure **Ethernet/IP Assemblies** is selected from the list at the left.
- b) Click **Export**.
The **Export to CSV & L5X** window opens.

Figure 183. Export to CSV & L5X

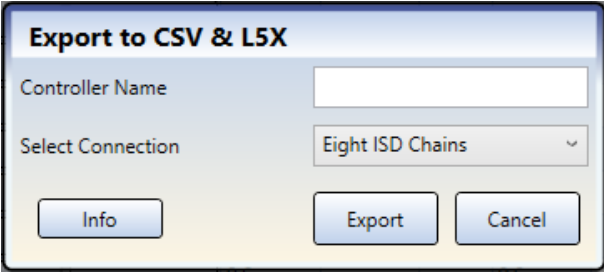

- c) In the **Controller Name** field, enter the name assigned to the Safety Controller in the PLC software.
- d) Select the desired connection in the **Select Connection** list.

Which connection to select is based on what Assembly Instances are being requested:

Table 10: Select Connection Field Choices

Connection Name	Output Assembly	Input Assembly
Status/Fault	112	100
Fault Index Words	112	101
Reset/Cancel Delay	112	103
VI Status/Faults	113	100
VI Fault Index Words	113	101
VI Reset/Cancel Delay	113	103
VRCD Plus ISD	114	104
Eight ISD Chains	114	105

If any virtual inputs (VI) are being used, the PLC's output assembly must be set to 113 or 114. This is so that the PLC can send the virtual input words to the Safety Controller. If information on the ISD inputs is desired with XS26-ISD FID 5 or later or SC10-2 FID 2 or later controllers, an output assembly of 114 must be used to send virtual inputs (if used) and the extra words to request the ISD information (VRCD—virtual reset/cancel delay).

Input assembly 104 is used for up to two ISD chains (by either XS26-ISD FID 5 or later, if the chains are added to IN1/IN2 and IN3/IN4, or SC10-2 FID 2 or later controllers). Input assembly 105 supports up to eight ISD chains and can be used only by XS26-ISD FID 5 or later.

- e) Click **Export**.
- f) Save the CSV files in the desired location.



Note: A .csv and a .L5X file are both saved.

The CSV file is ready to be directly imported into the Ethernet/IP Assembly PLC software or the file can be opened with any software that can read a CSV file (for example, Microsoft Excel).

- 16. Click **OK** twice and download the program to the PLC.

Figure 184. Download to the PLC

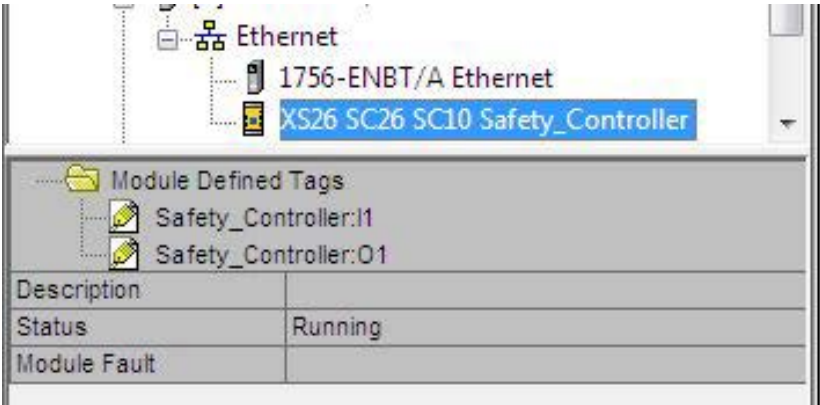

The connection looks like the one in [Figure 184](#) on page 181.

Examples of Incorrect Connection Choices

The following are examples of selecting an incorrect Connection from the EDS file.

Example 1

Attempting to use "VI Status/Fault (100)" connection on a Safety Controller that does not support Virtual Inputs; O>T Assembly Instance 113 does not exist for that hardware.

Figure 185. Incorrect: Using VI/Status Faults on a Safety Controller that does not support this feature

Module Defined Tags	
	Safety:I1
	Safety:O1
Description	
Status	IO Faulted
Module Fault	(Code 16#012a) Connection Request Error: Invalid output application path.

Example 2

Attempting to use "Reset/Cancel Delay (103)" connection on a Safety Controller that does not support Virtual Inputs; T>O Assembly Instance 103 does not exist for that hardware.

Figure 186. Incorrect: Reset/Cancel Delay on a Safety Controller that does not support this feature

Module Defined Tags	
	Safety:I1
	Safety:O1
Description	
Status	IO Faulted
Module Fault	(Code 16#012b) Connection Request Error: Invalid input application path

Example 3

Attempting to use "VRCD plus ISD (104)" connection on a Safety Controller that does not support ISD; T>O Assembly Instance 104 does not exist for that hardware.

Figure 187. Incorrect: VRCD plus ISD on a Safety Controller that does not support this feature

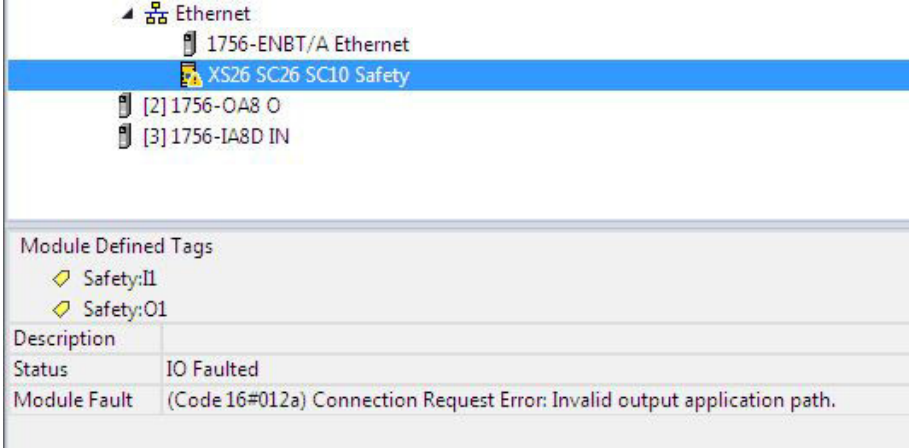

12.4.3 Generic Ethernet Module Connection

To create an implicit Class 1 configuration to the Safety Controller using EtherNet/IP when using a ControlLogix family PLC, configure the Safety Controller as a “Generic Ethernet Module”. The following is a sample setup of a Banner Engineering device.

Note: This is an example procedure.

1. Add a generic Ethernet module to the PLC’s Ethernet card.
 - a) Click **New Module**.

Figure 188. Add Ethernet Module

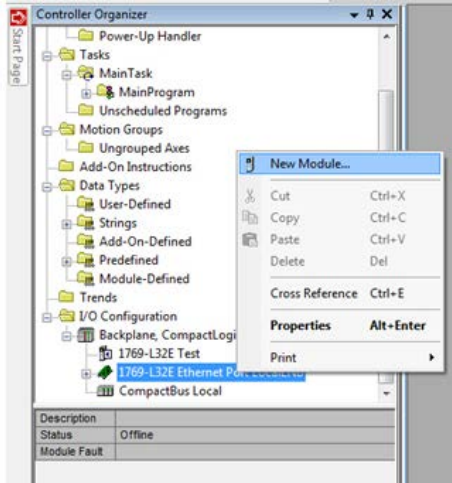

- b) From the catalog, click **Generic Ethernet Module**.

Figure 189. Select Module

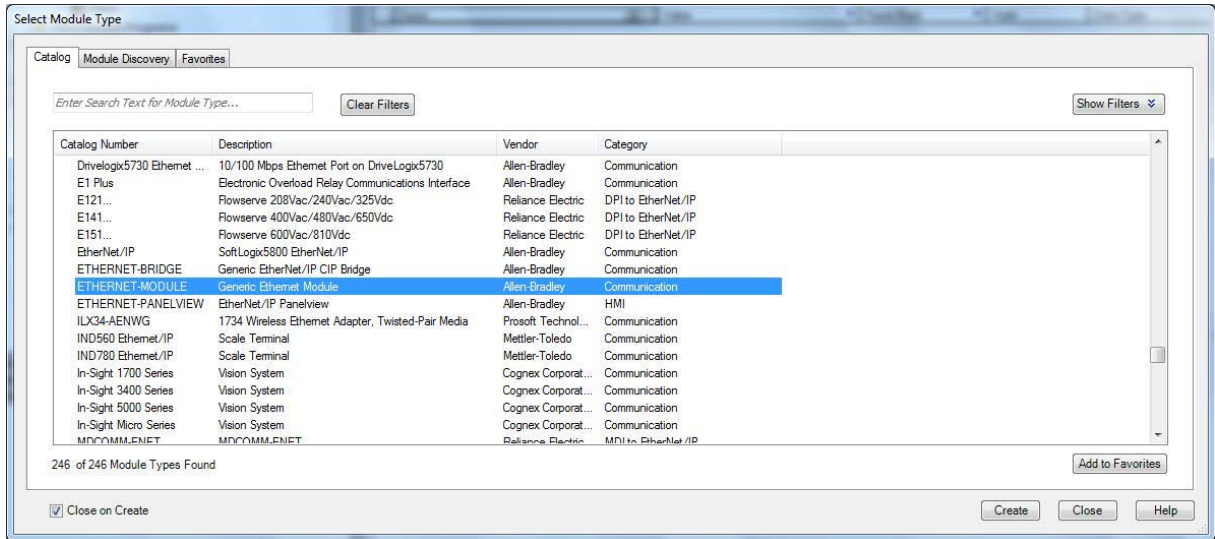

2. Configure the Module Properties.
 - a) Select **INT** from the **Comm Format** list (default is DINT).

Figure 190. Set Comm Format

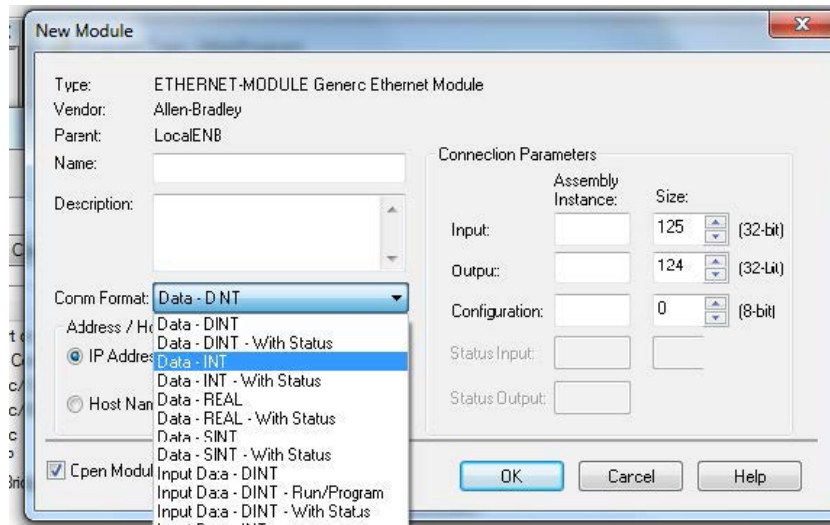

- b) Enter a module **Name** and the **IP Address** of the Safety Controller. The default Safety Controller IP address is 192.168.0.128 with a subnet mask of 255.255.255.0.

Figure 191. Add Name and IP Address

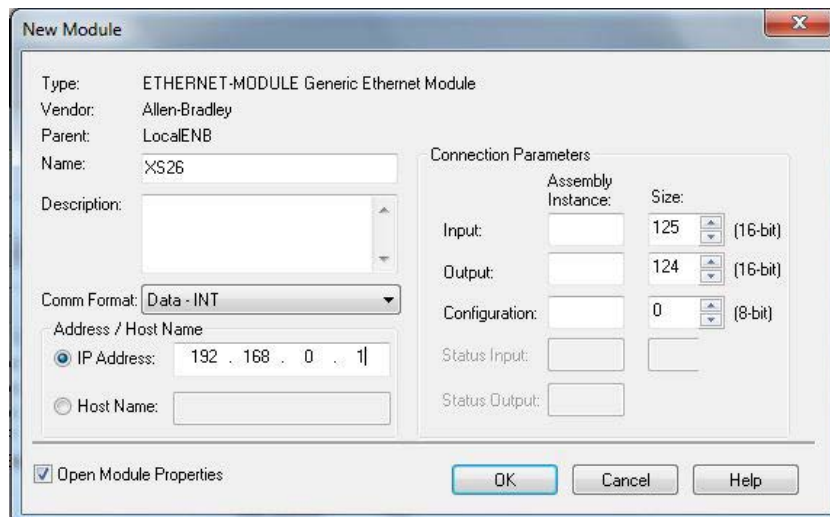

- c) Under Connection Parameters, select one of many possible Assembly Object setups. See [Inputs to the Safety Controller \(Outputs from the PLC\)](#) on page 189 and [Outputs from the Safety Controller \(Inputs to the PLC\)](#) on page 191 for more information on each choice.



Note: Select one of the O > T Assembly Instance 113 (0x71) connections to make use of Virtual Input/Cancel Delay.

Figure 192. PLC Input Assembly 100 (0x64), size 8 words (VO Status/Fault)

The 'New Module' dialog box is titled 'New Module' and contains the following information:

- Type: ETHERNET-MODULE Generic Ethernet Module
- Vendor: Allen-Bradley
- Parent: Ethernet
- Name: XS26
- Description: (empty text area)
- Comm Format: Data - INT
- Address / Host Name: IP Address: 192 . 168 . 0 . 128
- Connection Parameters:
 - Input: 100, Assembly Instance: 8, Size: (16-bit)
 - Output: 112, Assembly Instance: 2, Size: (16-bit)
 - Configuration: 128, Assembly Instance: 0, Size: (8-bit)
 - Status Input: (empty)
 - Status Output: (empty)
- Open Module Properties:
- Buttons: OK, Cancel, Help

Figure 193. PLC Input Assembly 101 (0x65), size 104 words (Fault Index Words)

The 'New Module' dialog box is titled 'New Module' and contains the following information:

- Type: ETHERNET-MODULE Generic Ethernet Module
- Vendor: Allen-Bradley
- Parent: Ethernet
- Name: XS26
- Description: (empty text area)
- Comm Format: Data - INT
- Address / Host Name: IP Address: 192 . 168 . 0 . 128
- Connection Parameters:
 - Input: 101, Assembly Instance: 104, Size: (16-bit)
 - Output: 112, Assembly Instance: 2, Size: (16-bit)
 - Configuration: 128, Assembly Instance: 0, Size: (8-bit)
 - Status Input: (empty)
 - Status Output: (empty)
- Open Module Properties:
- Buttons: OK, Cancel, Help

Figure 194. PLC Input Assembly 102 (0x66), size 150 words (Safety Controller Fault Log Only)

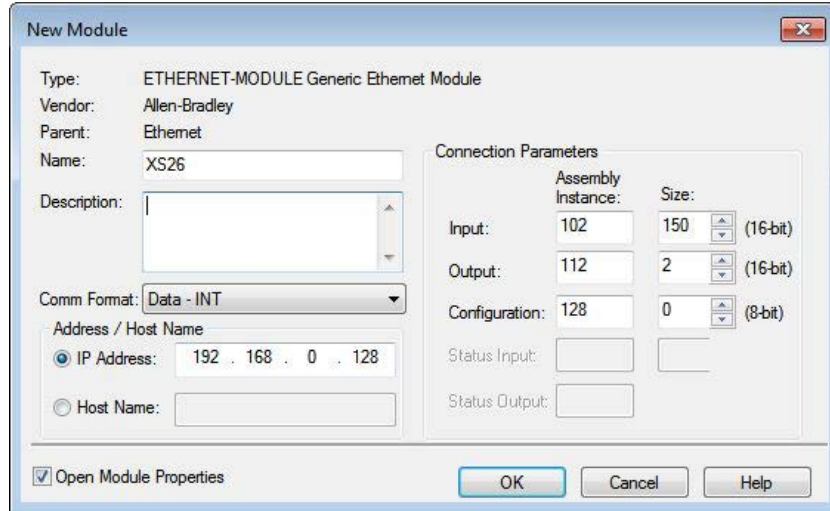

Figure 195. PLC Input Assembly 103 (0x67), size 35 words (Reset/Cancel Delay)

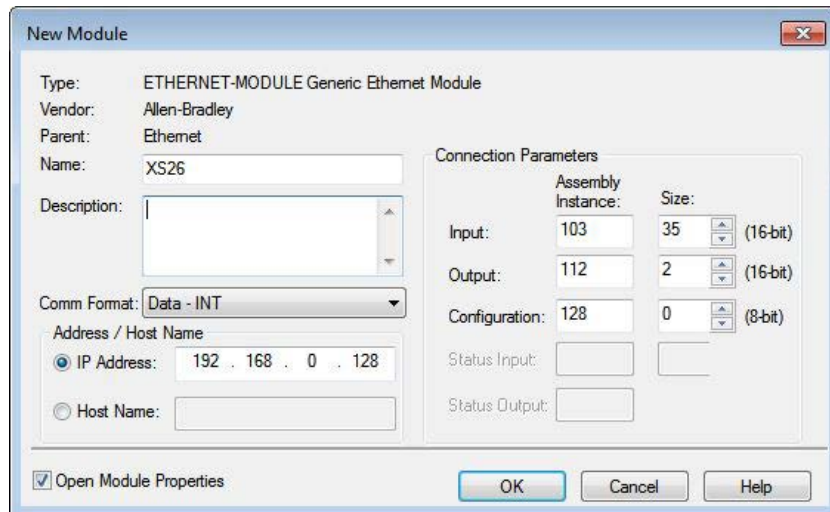

Figure 196. PLC Input Assembly 100 (0x64), size 8 words (VI Status/Fault)

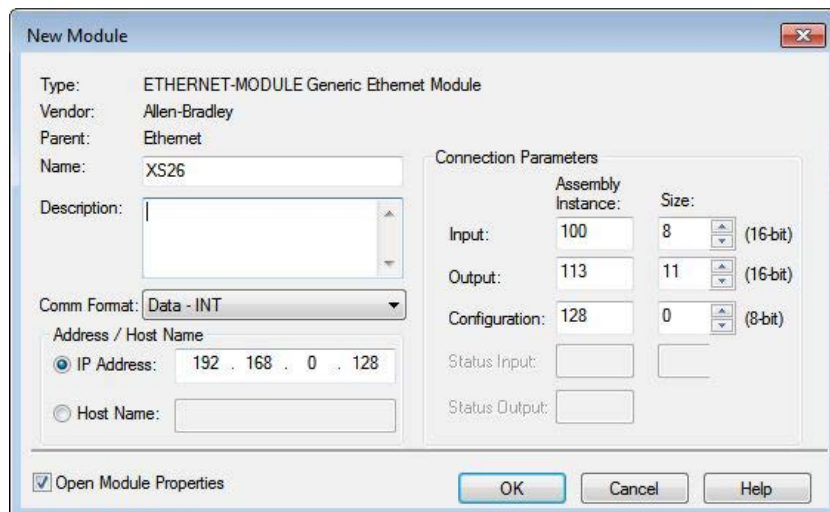

Figure 197. PLC Input Assembly 101 (0x65), size 104 words (VI Fault Index Words)

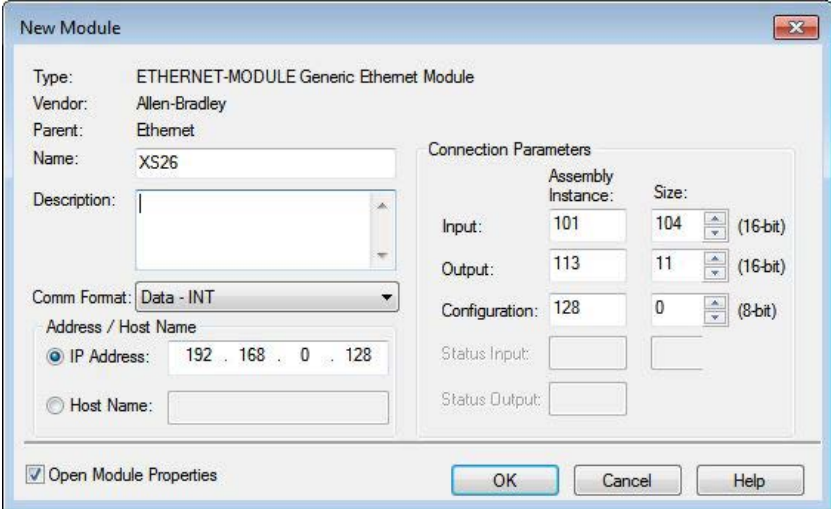

Figure 198. PLC Input Assembly 103 (0x67), size 35 words (VI Reset/Cancel Delay)

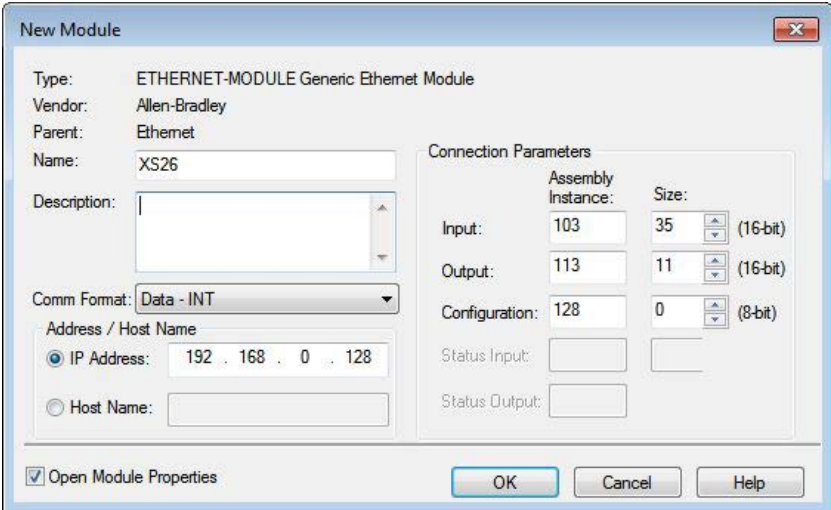

Figure 199. PLC Input Assembly 104 (0x68), size 112 words (VRCD plus ISD)

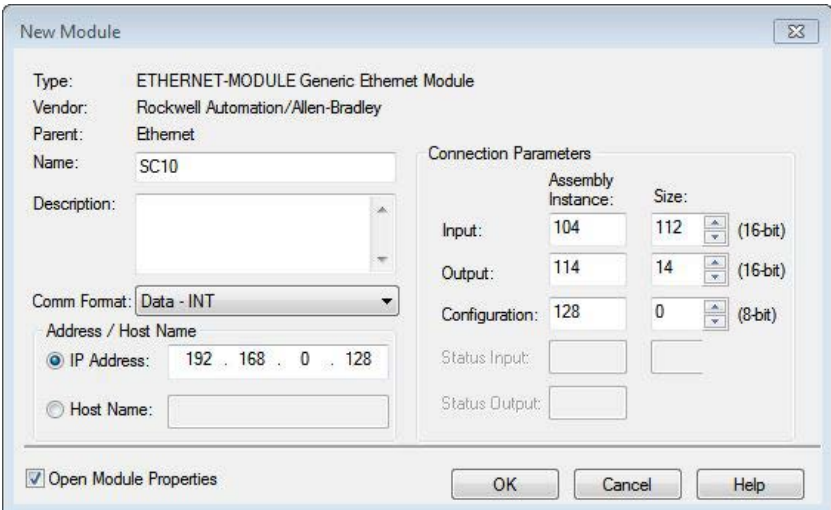
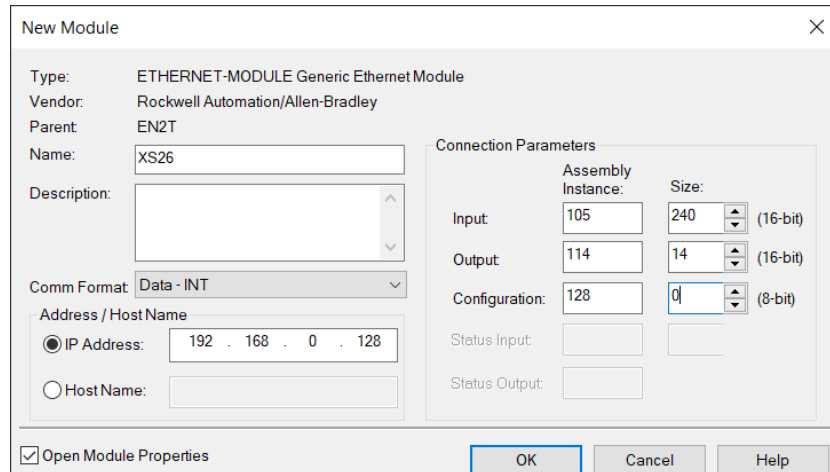

Figure 200. PLC Input Assembly 105 (0x69), size 240 words (8 ISD Chains)



d) Go to the **Connection** tab and set the parameters:

- Enter the desired **Requested Packet Interval (RPI)**
- Enable or disable **Use Unicast Connection over Ethernet/IP**, using the checkbox



Note: The recommended minimum RPI is 100 ms.

Figure 201. Connection Parameters

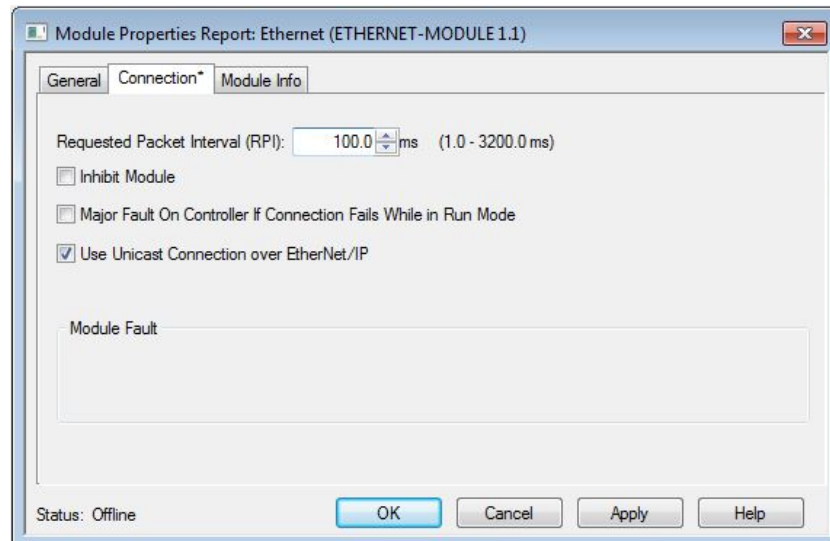

If the module configuration was successful, the following information displays:

Figure 202. Successful Configuration

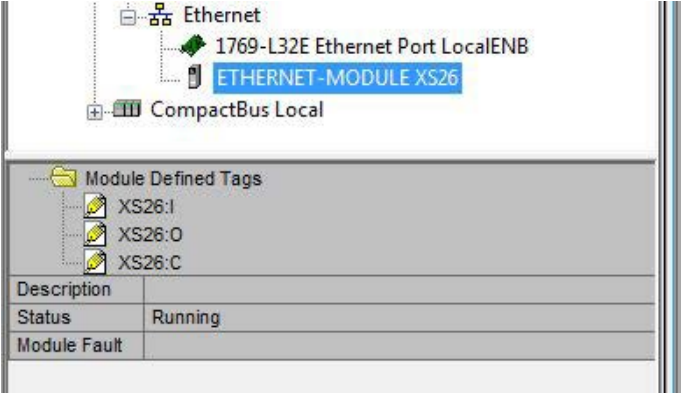

- I = Inputs to PLC (outputs from the Safety Controller)
- O = Outputs from PLC (inputs to the Safety Controller—not used)
- C = Configuration (not used)

3. Locate the memory map in the **Controller Tags** list. The 8 input words from Assembly Instance 100 are shown below as an example.

Figure 203. Memory Map

- XS26:I	{...}	{...}		AB:ETHERNET_MODULE
- XS26:I.Data	{...}	{...}	Decimal	INT[8]
+ XS26:I.Data[0]		1	Decimal	INT
+ XS26:I.Data[1]		128	Decimal	INT
+ XS26:I.Data[2]		0	Decimal	INT
+ XS26:I.Data[3]		8	Decimal	INT
+ XS26:I.Data[4]		0	Decimal	INT
+ XS26:I.Data[5]		0	Decimal	INT
+ XS26:I.Data[6]		0	Decimal	INT
+ XS26:I.Data[7]		0	Decimal	INT

In the example pictured above, we see that Virtual Outputs 1, 24, and 52 are ON.
 VO1 is word 0, bit 0 > 2^0 = 1
 VO24 is word 1, bit 7 > 2^7 = 128
 VO52 is word 3, bit 3 > 2^3 = 8

12.4.4 Inputs to the Safety Controller (Outputs from the PLC)

PLC Output Assembly Instance 112 (0x70)—2 Registers (Basic VI)

The Safety Controller can use Instance 112 (0x70) with a size of two registers (16-bit) when sending virtual inputs 1–32 to the Safety Controller.

Table 11: PLC Output Assembly Instance 112 (0x70)—Safety Controller Inputs O > T

WORD #	WORD NAME	DATA TYPE
0	Virtual Input On/Off (1–16)	16-bit integer
1	Virtual Input On/Off (17–32)	16-bit integer

PLC Output Assembly Instance 113 (0x71)—11 Registers (Expanded VI plus VRCD)

The Safety Controller uses Instance 113 (0x71)³³ with a size of eleven registers (16-bit) as its Input Assembly (PLC Output) when sending virtual inputs, resets, and cancel delays to the Safety Controller.

³³ This eleven word assembly is called 112 (0x70) for FID 2 Safety Controllers with date codes before and including "1716". See [Which XS/SC26 EDS file and documentation should you use?](#) on page 174 for more information.

Table 12: PLC Output Assembly Instance 113 (0x71)—Safety Controller Inputs O > T

WORD #	WORD NAME	DATA TYPE
0	Virtual Input On/Off (1–16)	16-bit integer
1	Virtual Input On/Off (17–32)	16-bit integer
2	Virtual Input On/Off (33–48)	16-bit integer
3	Virtual Input On/Off (49–64)	16-bit integer
4	<i>reserved</i>	16-bit integer
5	<i>reserved</i>	16-bit integer
6	<i>reserved</i>	16-bit integer
7	<i>reserved</i>	16-bit integer
8	Virtual Reset/Cancel Delay (1–16) [RCD Register Bits] (see Virtual Manual Reset and Cancel Delay (RCD) Sequence on page 61)	16-bit integer
9	<i>reserved</i>	16-bit integer
10	RCD Actuation Code [RCD Enable Register] (see Virtual Manual Reset and Cancel Delay (RCD) Sequence on page 61)	16-bit integer

PLC Output Assembly Instance 114 (0x72)—14 Registers (Expanded VI, VRCD, plus ISD)

The Safety Controller uses Instance 114 (0x72) with a size of fourteen registers (16-bit) as its Input Assembly (PLC Output) when sending virtual inputs, resets, and cancel delays to the safety controller and for obtaining performance and status information about ISD devices.

Table 13: PLC Output Assembly Instance 114 (0x72)—Safety Controller Inputs O > T

WORD #	WORD NAME	DATA TYPE
0	Virtual Input On/Off (1–16)	16-bit integer
1	Virtual Input On/Off (17–32)	16-bit integer
2	Virtual Input On/Off (33–48)	16-bit integer
3	Virtual Input On/Off (49–64)	16-bit integer
4	<i>reserved</i>	16-bit integer
5	<i>reserved</i>	16-bit integer
6	<i>reserved</i>	16-bit integer
7	<i>reserved</i>	16-bit integer
8	Virtual Reset/Cancel Delay (1–16) [RCD Register Bits] (see Virtual Manual Reset and Cancel Delay (RCD) Sequence on page 61)	16-bit integer
9	<i>reserved</i>	16-bit integer
10	RCD Actuation Code [RCD Enable Register] (see Virtual Manual Reset and Cancel Delay (RCD) Sequence on page 61)	16-bit integer
11	ISD Read Request (see Request Performance and Status Information about an Individual Device via ISD on page 50)	16-bit integer
12	ISD Chain Requested (see Request Performance and Status Information about an Individual Device via ISD on page 50)	16-bit integer
13	ISD Device Requested (see Request Performance and Status Information about an Individual Device via ISD on page 50)	16-bit integer

12.4.5 Outputs from the Safety Controller (Inputs to the PLC)

There are five choices for Safety Controller Output Assembly Objects.

The first and smallest choice includes information about Virtual Outputs and whether they have faults. The second choice adds advanced data such as the reason why each of the safety outputs is off, and more descriptive fault information for the Virtual Outputs. The third choice is used exclusively to access the Safety Controller's fault log. The fourth choice is used for the Virtual Manual Reset and Cancel Off Delay feedback. The fifth choice allows access to both Virtual Manual Reset and Cancel Delay feedback and ISD information. All five options are shown in the following sections.

PLC Input Assembly Instance 100 (0x64)—8 Registers (VO Status/Fault)

This Assembly Instance includes only basic information about the status of the first 64 Virtual Outputs.

Table 14: PLC Input Assembly Instance 100 (0x64)—Safety Controller Outputs T > O

WORD #	WORD NAME	DATA TYPE
0	VO1 – VO16 (see Flags on page 205)	16-bit integer
1	VO17 – VO32 (see Flags on page 205)	16-bit integer
2	VO33 – VO48 (see Flags on page 205)	16-bit integer
3	VO49 – VO64 (see Flags on page 205)	16-bit integer
4	Fault bits for VO1 – VO16 (see Flags on page 205)	16-bit integer
5	Fault bits for VO17 – VO32 (see Flags on page 205)	16-bit integer
6	Fault bits for VO33 – VO48 (see Flags on page 205)	16-bit integer
7	Fault bits for VO49 – VO64 (see Flags on page 205)	16-bit integer

PLC Input Assembly Instance 101 (0x65)—104 Registers (Fault Index Words)

This Assembly Instance includes the status of the first 64 Virtual Outputs plus advanced information about potential error codes and the status of the 2 safety outputs.

Table 15: PLC Input Assembly Instance 101 (0x65)—Safety Controller Outputs T > O

WORD #	WORD NAME	DATA TYPE
0	VO1 – VO16 (see Flags on page 205)	16-bit integer
1	VO17 – VO32 (see Flags on page 205)	16-bit integer
2	VO33 – VO48 (see Flags on page 205)	16-bit integer
3	VO49 – VO64 (see Flags on page 205)	16-bit integer
4	Fault bits for VO1 – VO16 (see Flags on page 205)	16-bit integer
5	Fault bits for VO17 – VO32 (see Flags on page 205)	16-bit integer
6	Fault bits for VO33 – VO48 (see Flags on page 205)	16-bit integer
7	Fault bits for VO49 – VO64 (see Flags on page 205)	16-bit integer
8–39	<i>reserved</i>	16-bit integer
40	VO1 Fault Index	16-bit integer
41	VO2 Fault Index	16-bit integer
42	VO3 Fault Index	16-bit integer
43	VO4 Fault Index	16-bit integer
44	VO5 Fault Index	16-bit integer
45	VO6 Fault Index	16-bit integer
46	VO7 Fault Index	16-bit integer
47	VO8 Fault Index	16-bit integer
48	VO9 Fault Index	16-bit integer

WORD #	WORD NAME	DATA TYPE
49	VO10 Fault Index	16-bit integer
50	VO11 Fault Index	16-bit integer
51	VO12 Fault Index	16-bit integer
52	VO13 Fault Index	16-bit integer
53	VO14 Fault Index	16-bit integer
54	VO15 Fault Index	16-bit integer
55	VO16 Fault Index	16-bit integer
56	VO17 Fault Index	16-bit integer
57	VO18 Fault Index	16-bit integer
58	VO19 Fault Index	16-bit integer
59	VO20 Fault Index	16-bit integer
60	VO21 Fault Index	16-bit integer
61	VO22 Fault Index	16-bit integer
62	VO23 Fault Index	16-bit integer
63	VO24 Fault Index	16-bit integer
64	VO25 Fault Index	16-bit integer
65	VO26 Fault Index	16-bit integer
66	VO27 Fault Index	16-bit integer
67	VO28 Fault Index	16-bit integer
68	VO29 Fault Index	16-bit integer
69	VO30 Fault Index	16-bit integer
70	VO31 Fault Index	16-bit integer
71	VO32 Fault Index	16-bit integer
72	VO33 Fault Index	16-bit integer
73	VO34 Fault Index	16-bit integer
74	VO35 Fault Index	16-bit integer
75	VO36 Fault Index	16-bit integer
76	VO37 Fault Index	16-bit integer
77	VO38 Fault Index	16-bit integer
78	VO39 Fault Index	16-bit integer
79	VO40 Fault Index	16-bit integer
80	VO41 Fault Index	16-bit integer
81	VO42 Fault Index	16-bit integer
82	VO43 Fault Index	16-bit integer
83	VO44 Fault Index	16-bit integer
84	VO45 Fault Index	16-bit integer
85	VO46 Fault Index	16-bit integer
86	VO47 Fault Index	16-bit integer
87	VO48 Fault Index	16-bit integer
88	VO49 Fault Index	16-bit integer

WORD #	WORD NAME	DATA TYPE
89	VO50 Fault Index	16-bit integer
90	VO51 Fault Index	16-bit integer
91	VO52 Fault Index	16-bit integer
92	VO53 Fault Index	16-bit integer
93	VO54 Fault Index	16-bit integer
94	VO55 Fault Index	16-bit integer
95	VO56 Fault Index	16-bit integer
96	VO57 Fault Index	16-bit integer
97	VO58 Fault Index	16-bit integer
98	VO59 Fault Index	16-bit integer
99	VO60 Fault Index	16-bit integer
100	VO61 Fault Index	16-bit integer
101	VO62 Fault Index	16-bit integer
102	VO63 Fault Index	16-bit integer
103	VO64 Fault Index	16-bit integer

Virtual Output (VO) Fault Index Words

The Virtual Output Fault Index number is a way to represent the Fault Code associated with a given Virtual Output as a single 16-bit integer. This value is equivalent to the Error Message Index value for a given Virtual Output. See [XS/SC26 Fault Code Table](#) on page 335 and [SC10-2 Fault Code Table](#) on page 340. Note that not every Virtual Output has an associated Fault Index.

PLC Input Assembly Instance 102 (0x66)—150 Registers (Error Log Only)

This Assembly Instance is used exclusively to access the fault log information on the Safety Controller.

Note that this Assembly Instance contains no information about the status of the Virtual Outputs.

The Safety Controller can store 10 faults in the log. Fault #1 is the most recent fault while higher fault numbers represent successively older faults.

Table 16: PLC Input Assembly Instance 102 (0—66) – Safety Controller Outputs $T > O$

WORD #	WORD NAME	DATA TYPE
0–1	Fault #1 Time Stamp	32-bit integer
2–9	Fault #1 Name of I/O or System	2-word length + 12-ASCII characters
10	Fault #1 Error Code	16-bit integer
11	Fault #1 Advanced Error Code	16-bit integer
12	Fault #1 Error Message Index	16-bit integer
13–14	<i>reserved</i>	16-bit integer
15–16	Fault #2 Time Stamp	32-bit integer
17–24	Fault #2 Name of I/O or System	2-word length + 12-ASCII characters
25	Fault #2 Error Code	16-bit integer
26	Fault #2 Advanced Error Code	16-bit integer
27	Fault #2 Error Message Index	16-bit integer
28–29	<i>reserved</i>	16-bit integer
30–31	Fault #3 Time Stamp	32-bit integer
32–39	Fault #3 Name of I/O or System	2-word length + 12-ASCII characters

WORD #	WORD NAME	DATA TYPE
40	Fault #3 Error Code	16-bit integer
41	Fault #3 Advanced Error Code	16-bit integer
42	Fault #3 Error Message Index	16-bit integer
43–44	<i>reserved</i>	16-bit integer
45–46	Fault #4 Time Stamp	32-bit integer
47–54	Fault #4 Name of I/O or System	2-word length + 12-ASCII characters
55	Fault #4 Error Code	16-bit integer
56	Fault #4 Advanced Error Code	16-bit integer
57	Fault #4 Error Message Index	16-bit integer
58–59	<i>reserved</i>	16-bit integer
60–61	Fault #5 Time Stamp	32-bit integer
62–69	Fault #5 Name of I/O or System	2-word length + 12-ASCII characters
70	Fault #5 Error Code	16-bit integer
71	Fault #5 Advanced Error Code	16-bit integer
72	Fault #5 Error Message Index	16-bit integer
73–74	<i>reserved</i>	16-bit integer
75–76	Fault #6 Time Stamp	32-bit integer
77–84	Fault #6 Name of I/O or System	2-word length + 12-ASCII characters
85	Fault #6 Error Code	16-bit integer
86	Fault #6 Advanced Error Code	16-bit integer
87	Fault #6 Error Message Index	16-bit integer
88–89	<i>reserved</i>	16-bit integer
90–91	Fault #7 Time Stamp	32-bit integer
92–99	Fault #7 Name of I/O or System	2-word length + 12-ASCII characters
100	Fault #7 Error Code	16-bit integer
101	Fault #7 Advanced Error Code	16-bit integer
102	Fault #7 Error Message Index	16-bit integer
103–104	<i>reserved</i>	16-bit integer
105–106	Fault #8 Time Stamp	32-bit integer
107–114	Fault #8 Name of I/O or System	2-word length + 12-ASCII characters
115	Fault #8 Error Code	16-bit integer
116	Fault #8 Advanced Error Code	16-bit integer
117	Fault #8 Error Message Index	16-bit integer
118–119	<i>reserved</i>	16-bit integer
120–121	Fault #9 Time Stamp	32-bit integer
122–129	Fault #9 Name of I/O or System	2-word length + 12-ASCII characters
130	Fault #9 Error Code	16-bit integer
131	Fault #9 Advanced Error Code	16-bit integer
132	Fault #9 Error Message Index	16-bit integer
133–134	<i>reserved</i>	16-bit integer

WORD #	WORD NAME	DATA TYPE
135–136	Fault #10 Time Stamp	32-bit integer
137–144	Fault #10 Name of I/O or System	2-word length + 12-ASCII characters
145	Fault #10 Error Code	16-bit integer
146	Fault #10 Advanced Error Code	16-bit integer
147	Fault #10 Error Message Index	16-bit integer
148–149	<i>reserved</i>	16-bit integer

Fault Time Stamp

The relative time, in seconds, when the fault occurred. As measured from time 0, which is the last time the Safety Controller was powered up.

Name of I/O or System

This is an ASCII-string describing the source of the fault.

Error Code, Advanced Error Code, Error Index Message

The Error Code and the Advanced Error Code, taken together, form the Safety Controller Fault Code. The format for the Fault Code is `Error Code 'dot' Advanced Error Code`. For example, a Safety Controller Fault Code of 2.1 is represented by an Error Code of 2 and an Advanced Error Code of 1. The Error Message Index value is the Error Code and the Advanced Error Code together, and includes a leading zero with the Advanced Error Code, if necessary. For example, a Safety Controller Fault Code of 2.1 is represented by an Error Message Index of 201.

The Error Message Index value is a convenient way to get the complete Fault Code while only reading a single 16-bit register.

PLC Input Assembly Instance 103 (0x67)—35 Registers (Reset/Cancel Delay)

This Assembly Instance is used to communicate the state of all 256 Virtual Outputs and Faults and to provide the feedback information required to execute virtual resets and cancel delays.

Table 17: PLC Input Assembly Instance 103 (0x67)—Safety Controller Outputs $T > 0$

WORD #	WORD NAME	DATA TYPE
0	VO1 – VO16 (see Flags on page 205)	16-bit integer
1	VO17 – VO32 (see Flags on page 205)	16-bit integer
2	VO33 – VO48 (see Flags on page 205)	16-bit integer
3	VO49 – VO64 (see Flags on page 205)	16-bit integer
4	VO65 – VO80 (see Extended Flags on page 206)	16-bit integer
5	VO81 – VO96 (see Extended Flags on page 206)	16-bit integer
6	VO97 – VO112 (see Extended Flags on page 206)	16-bit integer
7	VO113 – VO128 (see Extended Flags on page 206)	16-bit integer
8	VO129 – VO144 (see Extended Flags on page 206)	16-bit integer
9	VO145 – VO160 (see Extended Flags on page 206)	16-bit integer
10	VO161 – VO176 (see Extended Flags on page 206)	16-bit integer
11	VO177 – VO192 (see Extended Flags on page 206)	16-bit integer
12	VO193 – VO208 (see Extended Flags on page 206)	16-bit integer
13	VO209 – VO224 (see Extended Flags on page 206)	16-bit integer
14	VO225 – VO240 (see Extended Flags on page 206)	16-bit integer
15	VO241 – VO256 (see Extended Flags on page 206)	16-bit integer
16	Fault bits for VO1 – VO16 (see Flags on page 205)	16-bit integer
17	Fault bits for VO17 – VO32 (see Flags on page 205)	16-bit integer
18	Fault bits for VO33 – VO48 (see Flags on page 205)	16-bit integer

WORD #	WORD NAME	DATA TYPE
19	Fault bits for VO49 – VO64 (see Flags on page 205)	16-bit integer
20	Fault bits for VO65 – VO80 (see Extended Flags on page 206)	16-bit integer
21	Fault bits for VO81 – VO96 (see Extended Flags on page 206)	16-bit integer
22	Fault bits for VO97 – VO112 (see Extended Flags on page 206)	16-bit integer
23	Fault bits for VO113 – VO128 (see Extended Flags on page 206)	16-bit integer
24	Fault bits for VO129 – VO144 (see Extended Flags on page 206)	16-bit integer
25	Fault bits for VO145 – VO160 (see Extended Flags on page 206)	16-bit integer
26	Fault bits for VO161 – VO176 (see Extended Flags on page 206)	16-bit integer
27	Fault bits for VO177 – VO192 (see Extended Flags on page 206)	16-bit integer
28	Fault bits for VO193 – VO208 (see Extended Flags on page 206)	16-bit integer
29	Fault bits for VO209 – VO224 (see Extended Flags on page 206)	16-bit integer
30	Fault bits for VO225 – VO240 (see Extended Flags on page 206)	16-bit integer
31	Fault bits for VO241 – VO256 (see Extended Flags on page 206)	16-bit integer
32	Virtual Reset/Cancel Delay (1-16) Feedback [RCD Feedback Register Bits] (see Virtual Manual Reset and Cancel Delay (RCD) Sequence on page 61)	16-bit integer
33	<i>reserved</i>	16-bit integer
34	RCD Actuation Code Feedback [RCD Enable Feedback Register] (see Virtual Manual Reset and Cancel Delay (RCD) Sequence on page 61)	16-bit integer

PLC Input Assembly Instance 104 (0x68)—112 Registers (Reset/Cancel Delay plus ISD)

This Assembly Instance can be used by both the SC10-2 and XS26-ISD safety controllers.

The Assembly Instance includes the on/off state of all 256 Virtual Outputs and Faults, feedback required to execute virtual resets and cancel delays, and status information on up to two chains of ISD devices.

Note that Assembly Instance 105 (0x69) contains information on up to eight chains of ISD devices, but can only be used on the XS26-ISD.



Note: The ISD data is not immediately available upon power up. The ISD data can be delayed up to 10 seconds after the system power has been turned on

Table 18: PLC Input Assembly Instance 104 (0x68)—Safety Controller Outputs $T > O$

WORD #	WORD NAME	DATA TYPE
0	VO1 – VO16 (see Flags on page 205)	16-bit integer
1	VO17 – VO32 (see Flags on page 205)	16-bit integer
2	VO33 – VO48 (see Flags on page 205)	16-bit integer
3	VO49 – VO64 (see Flags on page 205)	16-bit integer
4	VO65 – VO80 (see Extended Flags on page 206)	16-bit integer
5	VO81 – VO96 (see Extended Flags on page 206)	16-bit integer
6	VO97 – VO112 (see Extended Flags on page 206)	16-bit integer
7	VO113 – VO128 (see Extended Flags on page 206)	16-bit integer
8	VO129 – VO144 (see Extended Flags on page 206)	16-bit integer
9	VO145 – VO160 (see Extended Flags on page 206)	16-bit integer
10	VO161 – VO176 (see Extended Flags on page 206)	16-bit integer

WORD #	WORD NAME	DATA TYPE
11	VO177 – VO192 (see Extended Flags on page 206)	16-bit integer
12	VO193 – VO208 (see Extended Flags on page 206)	16-bit integer
13	VO209 – VO224 (see Extended Flags on page 206)	16-bit integer
14	VO225 – VO240 (see Extended Flags on page 206)	16-bit integer
15	VO241 – VO256 (see Extended Flags on page 206)	16-bit integer
16	Fault bits for VO1 – VO16 (see Flags on page 205)	16-bit integer
17	Fault bits for VO17 – VO32 (see Flags on page 205)	16-bit integer
18	Fault bits for VO33 – VO48 (see Flags on page 205)	16-bit integer
19	Fault bits for VO49 – VO64 (see Flags on page 205)	16-bit integer
20	Fault bits for VO65 – VO80 (see Extended Flags on page 206)	16-bit integer
21	Fault bits for VO81 – VO96 (see Extended Flags on page 206)	16-bit integer
22	Fault bits for VO97 – VO112 (see Extended Flags on page 206)	16-bit integer
23	Fault bits for VO113 – VO128 (see Extended Flags on page 206)	16-bit integer
24	Fault bits for VO129 – VO144 (see Extended Flags on page 206)	16-bit integer
25	Fault bits for VO145 – VO160 (see Extended Flags on page 206)	16-bit integer
26	Fault bits for VO161 – VO176 (see Extended Flags on page 206)	16-bit integer
27	Fault bits for VO177 – VO192 (see Extended Flags on page 206)	16-bit integer
28	Fault bits for VO193 – VO208 (see Extended Flags on page 206)	16-bit integer
29	Fault bits for VO209 – VO224 (see Extended Flags on page 206)	16-bit integer
30	Fault bits for VO225 – VO240 (see Extended Flags on page 206)	16-bit integer
31	Fault bits for VO241 – VO256 (see Extended Flags on page 206)	16-bit integer
32	Virtual Reset/Cancel Delay (1–16) Feedback [RCD Feedback Register Bits] (see Virtual Manual Reset and Cancel Delay (RCD) Sequence on page 61)	16-bit integer
33	<i>reserved</i>	16-bit integer
34	RCD Actuation Code Feedback [RCD Enable Feedback Register] (see Virtual Manual Reset and Cancel Delay (RCD) Sequence on page 61)	16-bit integer
35–36	ISD System Status – Chain 1 Device Count	32-bit integer
37–38	ISD System Status – Chain 2 Device Count	32-bit integer
39–40	ISD System Status – Chain 1 Device On/Off Status (see ISD System Status Words on page 206)	32-bit integer
41–42	ISD System Status – Chain 2 Device On/Off Status (see ISD System Status Words on page 206)	32-bit integer
43–44	ISD System Status – Chain 1 Fault Status (see ISD System Status Words on page 206)	32-bit integer
45–46	ISD System Status – Chain 2 Fault Status (see ISD System Status Words on page 206)	32-bit integer
47–48	ISD System Status – Chain 1 Marginal Status (see ISD System Status Words on page 206)	32-bit integer
49–50	ISD System Status – Chain 2 Marginal Status (see ISD System Status Words on page 206)	32-bit integer
51–52	ISD System Status – Chain 1 Alert Status (see ISD System Status Words on page 206)	32-bit integer

WORD #	WORD NAME	DATA TYPE
53–54	ISD System Status – Chain 2 Alert Status (see ISD System Status Words on page 206)	32-bit integer
55–56	ISD System Status – Chain 1 Reset Status (see ISD System Status Words on page 206)	32-bit integer
57–58	ISD System Status – Chain 2 Reset Status (see ISD System Status Words on page 206)	32-bit integer
59–60	ISD System Status – Chain 1 Actuator Recognized (see ISD System Status Words on page 206)	32-bit integer
61–62	ISD System Status – Chain 2 Actuator Recognized (see ISD System Status Words on page 206)	32-bit integer
63–64	ISD System Status – Chain 1 System Status (see ISD Chain System Status on page 50)	32-bit integer
65–66	ISD System Status – Chain 2 System Status (see ISD Chain System Status on page 50)	32-bit integer
67–82	List of Detected ISD Devices on a Chain	Array of 32 bytes
83–99	<i>reserved</i>	16-bit integer
100	ISD Read Request Acknowledge (see Request Performance and Status Information about an Individual Device via ISD on page 50)	16-bit integer
101	ISD Chain Requested Acknowledge (see Request Performance and Status Information about an Individual Device via ISD on page 50)	16-bit integer
102	ISD Device Requested Acknowledge (see Request Performance and Status Information about an Individual Device via ISD on page 50)	16-bit integer
103–111	ISD Individual Device-Specific Data (see ISD Individual Device-Specific Data Detailed Description on page 202)	16-bit integer

PLC Input Assembly Instance 105 (0x69)—240 Registers (8 ISD Chains)

This Assembly Instance is used only by the XS26-ISD safety controllers.

The Assembly Instance includes the on/off state of all 256 Virtual Outputs and Faults, feedback required to execute virtual resets and cancel delays, and status information on up to eight chains of ISD devices.



Note: The ISD data is not immediately available upon power up. The ISD data can be delayed up to 10 seconds after the system power has been turned on

Table 19: PLC Input Assembly Instance 105 (0–69)—Safety Controller Outputs T > O

WORD #	WORD NAME	DATA TYPE
0	VO1 – VO16 (see Flags on page 205)	16-bit integer
1	VO17 – VO32 (see Flags on page 205)	16-bit integer
2	VO33 – VO48 (see Flags on page 205)	16-bit integer
3	VO49 – VO64 (see Flags on page 205)	16-bit integer
4	VO65 – VO80 (see Extended Flags on page 206)	16-bit integer
5	VO81 – VO96 (see Extended Flags on page 206)	16-bit integer
6	VO97 – VO112 (see Extended Flags on page 206)	16-bit integer
7	VO113 – VO128 (see Extended Flags on page 206)	16-bit integer
8	VO129 – VO144 (see Extended Flags on page 206)	16-bit integer
9	VO145 – VO160 (see Extended Flags on page 206)	16-bit integer

WORD #	WORD NAME	DATA TYPE
10	VO161 – VO176 (see Extended Flags on page 206)	16-bit integer
11	VO177 – VO192 (see Extended Flags on page 206)	16-bit integer
12	VO193 – VO208 (see Extended Flags on page 206)	16-bit integer
13	VO209 – VO224 (see Extended Flags on page 206)	16-bit integer
14	VO225 – VO240 (see Extended Flags on page 206)	16-bit integer
15	VO241 – VO256 (see Extended Flags on page 206)	16-bit integer
16	Fault bits for VO1 – VO16 (see Flags on page 205)	16-bit integer
17	Fault bits for VO17 – VO32 (see Flags on page 205)	16-bit integer
18	Fault bits for VO33 – VO48 (see Flags on page 205)	16-bit integer
19	Fault bits for VO49 – VO64 (see Flags on page 205)	16-bit integer
20	Fault bits for VO65 – VO80 (see Extended Flags on page 206)	16-bit integer
21	Fault bits for VO81 – VO96 (see Extended Flags on page 206)	16-bit integer
22	Fault bits for VO97 – VO112 (see Extended Flags on page 206)	16-bit integer
23	Fault bits for VO113 – VO128 (see Extended Flags on page 206)	16-bit integer
24	Fault bits for VO129 – VO144 (see Extended Flags on page 206)	16-bit integer
25	Fault bits for VO145 – VO160 (see Extended Flags on page 206)	16-bit integer
26	Fault bits for VO161 – VO176 (see Extended Flags on page 206)	16-bit integer
27	Fault bits for VO177 – VO192 (see Extended Flags on page 206)	16-bit integer
28	Fault bits for VO193 – VO208 (see Extended Flags on page 206)	16-bit integer
29	Fault bits for VO209 – VO224 (see Extended Flags on page 206)	16-bit integer
30	Fault bits for VO225 – VO240 (see Extended Flags on page 206)	16-bit integer
31	Fault bits for VO241 – VO256 (see Extended Flags on page 206)	16-bit integer
32	Virtual Reset/Cancel Delay (1 – 16) (see Virtual Manual Reset and Cancel Delay (RCD) Sequence on page 61)	16-bit integer
33	<i>reserved</i>	16-bit integer
34	RCD Enable Feedback (see Virtual Manual Reset and Cancel Delay (RCD) Sequence on page 61)	16-bit integer
35–36	ISD System Status – Chain 1 Device Count	32-bit integer
37–38	ISD System Status – Chain 2 Device Count	32-bit integer
39–40	ISD System Status – Chain 1 Device On/Off Status (see ISD System Status Words on page 206)	32-bit integer
41–42	ISD System Status – Chain 2 Device On/Off Status (see ISD System Status Words on page 206)	32-bit integer
43–44	ISD System Status – Chain 1 Fault Status (see ISD System Status Words on page 206)	32-bit integer
45–46	ISD System Status – Chain 2 Fault Status (see ISD System Status Words on page 206)	32-bit integer
47–48	ISD System Status – Chain 1 Marginal Status (see ISD System Status Words on page 206)	32-bit integer
49–50	ISD System Status – Chain 2 Marginal Status (see ISD System Status Words on page 206)	32-bit integer
51–52	ISD System Status – Chain 1 Alert Status (see ISD System Status Words on page 206)	32-bit integer

WORD #	WORD NAME	DATA TYPE
53–54	ISD System Status – Chain 2 Alert Status (see ISD System Status Words on page 206)	32-bit integer
55–56	ISD System Status – Chain 1 Reset Status (see ISD System Status Words on page 206)	32-bit integer
57–58	ISD System Status – Chain 2 Reset Status (see ISD System Status Words on page 206)	32-bit integer
59–60	ISD System Status – Chain 1 Actuator Recognized Status (see ISD System Status Words on page 206)	32-bit integer
61–62	ISD System Status – Chain 2 Actuator Recognized Status (see ISD System Status Words on page 206)	32-bit integer
63–64	ISD System Status – Chain 1 System Status (see ISD Chain System Status on page 50)	32-bit integer
65–66	ISD System Status – Chain 2 System Status (see ISD Chain System Status on page 50)	32-bit integer
67–82	List of Detected ISD Devices on a Chain	Array of 32 bytes
83–99	<i>reserved</i>	16-bit integer
100	ISD Read Request Acknowledge	16-bit integer
101	ISD Chain Requested Acknowledge	16-bit integer
102	ISD Device Requested Acknowledge	16-bit integer
103–111	ISD Individual Device-Specific Data	16-bit integer
112–113	ISD System Status – Chain 1 Device Count	32-bit integer
114–115	ISD System Status – Chain 1 Device On/Off Status (see ISD System Status Words on page 206)	32-bit integer
116–117	ISD System Status – Chain 1 Fault Status (see ISD System Status Words on page 206)	32-bit integer
118–119	ISD System Status – Chain 1 Marginal Status (see ISD System Status Words on page 206)	32-bit integer
120–121	ISD System Status – Chain 1 Alert Status (see ISD System Status Words on page 206)	32-bit integer
122–123	ISD System Status – Chain 1 Reset Status (see ISD System Status Words on page 206)	32-bit integer
124–125	ISD System Status – Chain 1 Actuator Recognized Status (see ISD System Status Words on page 206)	32-bit integer
126–127	ISD System Status – Chain 1 System Status (see ISD Chain System Status on page 50)	32-bit integer
128–129	ISD System Status – Chain 2 Device Count	32-bit integer
130–131	ISD System Status – Chain 2 Device On/Off Status (see ISD System Status Words on page 206)	32-bit integer
132–133	ISD System Status – Chain 2 Fault Status (see ISD System Status Words on page 206)	32-bit integer
134–135	ISD System Status – Chain 2 Marginal Status (see ISD System Status Words on page 206)	32-bit integer
136–137	ISD System Status – Chain 2 Alert Status (see ISD System Status Words on page 206)	32-bit integer
138–139	ISD System Status – Chain 2 Reset Status (see ISD System Status Words on page 206)	32-bit integer
140–141	ISD System Status – Chain 2 Actuator Recognized Status (see ISD System Status Words on page 206)	32-bit integer

WORD #	WORD NAME	DATA TYPE
142–143	ISD System Status – Chain 2 System Status (see ISD Chain System Status on page 50)	32-bit integer
144–145	ISD System Status – Chain 3 Device Count	32-bit integer
146–147	ISD System Status – Chain 3 Device On/Off Status (see ISD System Status Words on page 206)	32-bit integer
148–149	ISD System Status – Chain 3 Fault Status (see ISD System Status Words on page 206)	32-bit integer
150–151	ISD System Status – Chain 3 Marginal Status (see ISD System Status Words on page 206)	32-bit integer
152–153	ISD System Status – Chain 3 Alert Status (see ISD System Status Words on page 206)	32-bit integer
154–155	ISD System Status – Chain 3 Reset Status (see ISD System Status Words on page 206)	32-bit integer
156–157	ISD System Status – Chain 3 Actuator Recognized Status (see ISD System Status Words on page 206)	32-bit integer
158–159	ISD System Status – Chain 3 System Status (see ISD Chain System Status on page 50)	32-bit integer
160–161	ISD System Status – Chain 4 Device Count	32-bit integer
162–163	ISD System Status – Chain 4 Device On/Off Status (see ISD System Status Words on page 206)	32-bit integer
164–165	ISD System Status – Chain 4 Fault Status (see ISD System Status Words on page 206)	32-bit integer
166–167	ISD System Status – Chain 4 Marginal Status (see ISD System Status Words on page 206)	32-bit integer
168–169	ISD System Status – Chain 4 Alert Status (see ISD System Status Words on page 206)	32-bit integer
170–171	ISD System Status – Chain 4 Reset Status (see ISD System Status Words on page 206)	32-bit integer
172–173	ISD System Status – Chain 4 Actuator Recognized Status (see ISD System Status Words on page 206)	32-bit integer
174–175	ISD System Status – Chain 4 System Status (see ISD Chain System Status on page 50)	32-bit integer
176–177	ISD System Status – Chain 5 Device Count	32-bit integer
178–179	ISD System Status – Chain 5 Device On/Off Status (see ISD System Status Words on page 206)	32-bit integer
180–181	ISD System Status – Chain 5 Fault Status (see ISD System Status Words on page 206)	32-bit integer
182–183	ISD System Status – Chain 5 Marginal Status (see ISD System Status Words on page 206)	32-bit integer
184–185	ISD System Status – Chain 5 Alert Status (see ISD System Status Words on page 206)	32-bit integer
186–187	ISD System Status – Chain 5 Reset Status (see ISD System Status Words on page 206)	32-bit integer
188–189	ISD System Status – Chain 5 Actuator Recognized Status (see ISD System Status Words on page 206)	32-bit integer
190–191	ISD System Status – Chain 5 System Status (see ISD Chain System Status on page 50)	32-bit integer
192–193	ISD System Status – Chain 6 Device Count	32-bit integer

WORD #	WORD NAME	DATA TYPE
194–195	ISD System Status – Chain 6 Device On/Off Status (see ISD System Status Words on page 206)	32-bit integer
196–197	ISD System Status – Chain 6 Fault Status (see ISD System Status Words on page 206)	32-bit integer
198–199	ISD System Status – Chain 6 Marginal Status (see ISD System Status Words on page 206)	32-bit integer
200–201	ISD System Status – Chain 6 Alert Status (see ISD System Status Words on page 206)	32-bit integer
202–203	ISD System Status – Chain 6 Reset Status (see ISD System Status Words on page 206)	32-bit integer
204–205	ISD System Status – Chain 6 Actuator Recognized Status (see ISD System Status Words on page 206)	32-bit integer
206–207	ISD System Status – Chain 6 System Status (see ISD Chain System Status on page 50)	32-bit integer
208–209	ISD System Status – Chain 7 Device Count	32-bit integer
210–211	ISD System Status – Chain 7 Device On/Off Status (see ISD System Status Words on page 206)	32-bit integer
212–213	ISD System Status – Chain 7 Fault Status (see ISD System Status Words on page 206)	32-bit integer
214–215	ISD System Status – Chain 7 Marginal Status (see ISD System Status Words on page 206)	32-bit integer
216–217	ISD System Status – Chain 7 Alert Status (see ISD System Status Words on page 206)	32-bit integer
218–219	ISD System Status – Chain 7 Reset Status (see ISD System Status Words on page 206)	32-bit integer
220–221	ISD System Status – Chain 7 Actuator Recognized Status (see ISD System Status Words on page 206)	32-bit integer
222–223	ISD System Status – Chain 7 System Status (see ISD Chain System Status on page 50)	32-bit integer
224–225	ISD System Status – Chain 8 Device Count	32-bit integer
226–227	ISD System Status – Chain 8 Device On/Off Status (see ISD System Status Words on page 206)	32-bit integer
228–229	ISD System Status – Chain 8 Fault Status (see ISD System Status Words on page 206)	32-bit integer
230–231	ISD System Status – Chain 8 Marginal Status (see ISD System Status Words on page 206)	32-bit integer
232–233	ISD System Status – Chain 8 Alert Status (see ISD System Status Words on page 206)	32-bit integer
234–235	ISD System Status – Chain 8 Reset Status (see ISD System Status Words on page 206)	32-bit integer
236–237	ISD System Status – Chain 8 Actuator Recognized Status (see ISD System Status Words on page 206)	32-bit integer
238–239	ISD System Status – Chain 8 System Status (see ISD Chain System Status on page 50)	32-bit integer

ISD Individual Device-Specific Data Detailed Description

The following table describes Assembly Instance 104 (0x68) WORD #103–111 or Explicit Message Read ISD Response WORD #68–76.

Table 20: ISD Individual Device-Specific Data Detailed Description

WORD.BIT #	Information	Data size
103.0	Safety Input Fault	1 bit
103.1	<i>reserved</i>	1 bit
103.2	Sensor Not Paired	1-bit
103.3	ISD Data Error	1-bit
103.4	Wrong Actuator/Button Status/Input Status	1-bit
103.5	Marginal Range/Button Status/Input Status	1-bit
103.6	Actuator Detected	1-bit
103.7	Output Error	1-bit
103.8	Input 2	1-bit
103.9	Input 1	1-bit
103.10	Local Reset Expected	1-bit
103.11	Operating Voltage Warning	1-bit
103.12	Operating Voltage Error	1-bit
103.13	Output 2	1-bit
103.14	Output 1	1-bit
103.15	Power Cycle Required	1-bit
104.0	Fault Tolerant Outputs	1-bit
104.1	Local Reset Unit	1-bit
104.2	Cascadable	1-bit
104.3	High Coding Level	1-bit
104.4 to 104.7	Teach-ins Remaining	4-bit
104.8 to 104.12	Device ID	5-bit
104.13 to 105.2	Range Warning Count	6-bit
105.3 to 105.7	Output Switch-off Time	5-bit
105.8 to 105.15	Number of Voltage Errors	8-bit
106.0 to 106.7	Internal Temperature ³⁵	8-bit
106.8 to 106.15	Actuator Distance ³⁵	8-bit
107.0 to 107.7	Supply Voltage ³⁵	8-bit
107.8 to 107.11	Expected Company Name	4-bit
107.12 to 107.15	Received Company Name	4-bit
108	Expected Code	16-bit
109	Received Code	16-bit
110	Internal Error A	16-bit
111	Internal Error B	16-bit

12.4.6 Configuration Assembly Object

The Safety Controller does not use a Configuration Assembly Object.

Because some EtherNet/IP clients require one, use Instance 128 (0×80) with a size of zero registers (16-bit).

³⁵ For conversion to Internal Temperature, Actuator Distance, and Supply Voltage, see [ISD: Temperature, Voltage, and Distance Conversion Information](#) on page 296.

12.4.7 Fault Examples

The following figure shows a fault from the Banner Safety Controller Software fault log.

Figure 204. Fault Log with One Fault

Number	Time	Type	Source	Code
5	00:32:30	Input	M0:THC1	2.2

Buttons: Clear Fault Log, Close

The following figure shows the same fault as seen in the EtherNet/IP registers.

Figure 205. EtherNet/IP Registers with One Fault

Register	Value	Unit	Address
XS26:I	{...}	{...}	AB:ETHER
XS26:I.Data	{...}	{...}	Decimal INT[150]
XS26:I.Data[0]	1950	Decimal	INT
XS26:I.Data[1]	0	Decimal	INT
XS26:I.Data[2]	4	Decimal	INT
XS26:I.Data[3]	0	Decimal	INT
XS26:I.Data[4]	'HT'	ASCII	INT
XS26:I.Data[5]	'1C'	ASCII	INT
XS26:I.Data[6]	0	Decimal	INT
XS26:I.Data[7]	0	Decimal	INT
XS26:I.Data[8]	0	Decimal	INT
XS26:I.Data[9]	0	Decimal	INT
XS26:I.Data[10]	2	Decimal	INT
XS26:I.Data[11]	2	Decimal	INT
XS26:I.Data[12]	202	Decimal	INT
XS26:I.Data[13]	34	Decimal	INT
XS26:I.Data[14]	1	Decimal	INT

Annotations:

- Time Stamp: XS26:I.Data[0]
- I/O or System Name Length (# of ASCII Characters): XS26:I.Data[2]
- I/O or System Name Length (Space for 12 of ASCII Characters): XS26:I.Data[6]
- Error Code: XS26:I.Data[10]
- Advanced Error Code: XS26:I.Data[11]
- Fault Error Message Index: XS26:I.Data[12]
- Reserved: XS26:I.Data[14]

Note the ControlLogix string format, wherein the ASCII characters are shown, two per register, backwards. “THC1” becomes “HT” in register 4, followed by “1C” in register 5.

Fault Error Message Index 202 = Fault Code 2.2 (Simultaneity Fault). For more Fault information, see [XS/SC26 Fault Code Table](#) on page 335 or [SC10-2 Fault Code Table](#) on page 340.

The following figure shows two faults in the XS26-2E software fault log.

Figure 206. Fault Log with Two Faults

Number	Time	Type	Source	Code
6	00:35:25	Input	M0:THC1	2.2
5	00:32:30	Input	M0:THC1	2.2

Buttons: Clear Fault Log, Close

The following figure shows the same two faults in the PLC registers. Note how the newer Error #2 pushes Error #1 down the list.

Figure 207. EtherNet/IP Registers with Two Faults

Register	Value	Unit	AB:ETHERNET_...
XS26.I.Data	{...}	Decimal	INT[150]
XS26.I.Data[0]	2125	Decimal	INT
XS26.I.Data[1]	0	Decimal	INT
XS26.I.Data[2]	4	Decimal	INT
XS26.I.Data[3]	0	Decimal	INT
XS26.I.Data[4]	'HT'	ASCII	INT
XS26.I.Data[5]	'1C'	ASCII	INT
XS26.I.Data[6]	0	Decimal	INT
XS26.I.Data[7]	0	Decimal	INT
XS26.I.Data[8]	0	Decimal	INT
XS26.I.Data[9]	0	Decimal	INT
XS26.I.Data[10]	2	Decimal	INT
XS26.I.Data[11]	2	Decimal	INT
XS26.I.Data[12]	202	Decimal	INT
XS26.I.Data[13]	34	Decimal	INT
XS26.I.Data[14]	1	Decimal	INT
XS26.I.Data[15]	1950	Decimal	INT
XS26.I.Data[16]	0	Decimal	INT
XS26.I.Data[17]	4	Decimal	INT
XS26.I.Data[18]	0	Decimal	INT
XS26.I.Data[19]	'HT'	ASCII	INT
XS26.I.Data[20]	'1C'	ASCII	INT
XS26.I.Data[21]	0	Decimal	INT
XS26.I.Data[22]	0	Decimal	INT
XS26.I.Data[23]	0	Decimal	INT
XS26.I.Data[24]	0	Decimal	INT
XS26.I.Data[25]	2	Decimal	INT
XS26.I.Data[26]	2	Decimal	INT
XS26.I.Data[27]	202	Decimal	INT
XS26.I.Data[28]	34	Decimal	INT
XS26.I.Data[29]	1	Decimal	INT

Error #2

Error #1

12.4.8 Flags

Words 0 through 7, defined below, appear as the first 8 words in Assembly Instances 100, 101, and 103.

Table 21: Word #0, Virtual Output 1–16

Bit Position															
15	14	13	12	11	10	9	8	7	6	5	4	3	2	1	0
VO16	VO15	VO14	VO13	VO12	VO11	VO10	VO9	VO8	VO7	VO6	VO5	VO4	VO3	VO2	VO1

Table 22: Word #1, Virtual Output 17–32

Bit Position															
15	14	13	12	11	10	9	8	7	6	5	4	3	2	1	0
VO32	VO31	VO30	VO29	VO28	VO27	VO26	VO25	VO24	VO23	VO22	VO21	VO20	VO19	VO18	VO17

Table 23: Word #2, Virtual Output 33–48

Bit Position															
15	14	13	12	11	10	9	8	7	6	5	4	3	2	1	0
VO48	VO47	VO46	VO45	VO44	VO43	VO42	VO41	VO40	VO39	VO38	VO37	VO36	VO35	VO34	VO33

Table 24: Word #3, Virtual Output 49–64

Bit Position															
15	14	13	12	11	10	9	8	7	6	5	4	3	2	1	0
VO64	VO63	VO62	VO61	VO60	VO59	VO58	VO57	VO56	VO55	VO54	VO53	VO52	VO51	VO50	VO49

Table 25: Word #4, Fault Flag bits for Virtual Output 1–16

Note that not every Virtual Output has a defined Fault Flag.

Bit Position															
15	14	13	12	11	10	9	8	7	6	5	4	3	2	1	0
VO16	VO15	VO14	VO13	VO12	VO11	VO10	VO9	VO8	VO7	VO6	VO5	VO4	VO3	VO2	VO1

Table 26: Word #5, Fault Flag bits for Virtual Output 17–32 Fault Flag

Note that not every Virtual Output has a defined Fault Flag.

Bit Position															
15	14	13	12	11	10	9	8	7	6	5	4	3	2	1	0
VO32	VO31	VO30	VO29	VO28	VO27	VO26	VO25	VO24	VO23	VO22	VO21	VO20	VO19	VO18	VO17

Table 27: Word #6, Fault Flag bits for Virtual Output 33–48

Note that not every Virtual Output has a defined Fault Flag.

Bit Position															
15	14	13	12	11	10	9	8	7	6	5	4	3	2	1	0
VO48	VO47	VO46	VO45	VO44	VO43	VO42	VO41	VO40	VO39	VO38	VO37	VO36	VO35	VO34	VO33

Table 28: Word #7, Fault Flag bits for Virtual Output 49–64

Note that not every Virtual Output has a defined Fault Flag.

Bit Position															
15	14	13	12	11	10	9	8	7	6	5	4	3	2	1	0
VO64	VO63	VO62	VO61	VO60	VO59	VO58	VO57	VO56	VO55	VO54	VO53	VO52	VO51	VO50	VO49

12.4.9 Extended Flags

In addition to the first 64 virtual outputs listed above, Assembly Instance 103 adds 192 more (for a total of 256). The fault flag bits shift downward to make room for all 256 virtual outputs to be together.

Words 0 through 3 are the same as seen in [Flags](#) on page 205. In the case of Assembly Instance 103 the following changes are made:

- Word #4 – Virtual Outputs 65 through 80, where VO65 is found in bit 0 and VO80 in bit 15
- Word #5 – Virtual Outputs 81 through 96, where VO81 is found in bit 0 and VO96 in bit 15
- Word #6 – Virtual Outputs 97 through 112, where VO97 is found in bit 0 and VO112 in bit 15
- Word #7 – Virtual Outputs 113 through 128, where VO113 is found in bit 0 and VO128 in bit 15
- Word #8 – Virtual Outputs 129 through 144, where VO129 is found in bit 0 and VO144 in bit 15
- Word #9 – Virtual Outputs 145 through 160, where VO145 is found in bit 0 and VO160 in bit 15
- Word #10 – Virtual Outputs 161 through 176, where VO161 is found in bit 0 and VO176 in bit 15
- Word #11 – Virtual Outputs 177 through 192, where VO177 is found in bit 0 and VO192 in bit 15
- Word #12 – Virtual Outputs 193 through 208, where VO193 is found in bit 0 and VO208 in bit 15
- Word #13 – Virtual Outputs 209 through 224, where VO209 is found in bit 0 and VO224 in bit 15
- Word #14 – Virtual Outputs 225 through 240, where VO225 is found in bit 0 and VO240 in bit 15
- Word #15 – Virtual Outputs 241 through 256, where VO241 is found in bit 0 and VO256 in bit 15
- Word #16 through #19 are the same as Word #4 through #7 as seen in [Flags](#) on page 205. Assembly Instance 103 also includes more fault flag bits, as seen below
- Word #20 – Fault Bits for VO65 through VO80, where the fault for VO65 is found in bit 0 and VO80 in bit 15

This pattern continues for Word #21 through #31, covering the remainder of the fault bits for the 256 total Virtual Outputs.

12.4.10 ISD System Status Words

The ISD System Status words as found in PLC Input Assembly Instance 104 (0x68), words 39–62, are defined below.

Each of these System Status Words are not meant to be seen as a single 32-bit integer, but rather as an array of 32 individual ISD device status bits, where bit 0 is assigned to ISD device 1, bit 1 is assigned to ISD device 2, and so on until bit 31 is assigned to the 32nd ISD device on that chain.

- Word #39–40 Chain 1 Device On/Off Status—Chain 1, ISD device 1 on/off is Word 39, bit 0; chain 1, ISD device 32 on/off is Word 40, bit 15
- Word #41–42 Chain 2 Device On/Off Status—Chain 2, ISD device 1 on/off is Word 41, bit 0; chain 2, ISD device 32 on/off is Word 42, bit 15
- Word #43–44 Chain 1 Fault Status—Chain 1, ISD device 1 fault status is Word 43, bit 0; chain 1, ISD device 32 fault status is Word 44, bit 15

- Word #45–46 Chain 2 Fault Status—Chain 2, ISD device 1 fault status is Word 45, bit 0; chain 2, ISD device 32 fault status is Word 46, bit 15
- Word #47–48 Chain 1 Marginal Status—Chain 1, ISD device 1 marginal status is Word 47, bit 0; chain 1, ISD device 32 marginal status is Word 48, bit 15
- Word #49–50 Chain 2 Marginal Status—Chain 2, ISD device 1 marginal status is Word 49, bit 0; chain 2, ISD device 32 marginal status is Word 50, bit 15
- Word #51–52 Chain 1 Alert Status—Chain 1, ISD device 1 alert status is Word 51, bit 0; chain 1, ISD device 32 alert status is Word 52, bit 15
- Word #53–54 Chain 2 Alert Status—Chain 2, ISD device 1 alert status is Word 53, bit 0; chain 2, ISD device 32 alert status is Word 54, bit 15
- Word #55–56 Chain 1 Reset Status—Chain 1, ISD device 1 reset status is Word 55, bit 0; chain 1, ISD device 32 reset status is Word 56, bit 15
- Word #57–58 Chain 2 Reset Status—Chain 2, ISD device 1 reset status is Word 57, bit 0; chain 2, ISD device 32 reset status is Word 58, bit 15
- Word #59–60 Chain 1 Actuator Recognized—Chain 1, ISD device 1 actuator recognized is Word 59, bit 0; chain 1, ISD device 32 actuator recognized is Word 60, bit 15
- Word #61–62 Chain 2 Actuator Recognized—Chain 2, ISD device 1 actuator recognized is Word 61, bit 0; chain 2, ISD device 32 actuator recognized is Word 62, bit 15

12.4.11 RSLogix5000 Configuration (Explicit Messaging)

To get a specific Fault Index Value for one of the first 255 Virtual Outputs, use Explicit Messaging connections. In addition to the Assembly Instances from the previous section, there are some extra Assembly Instances that can only be accessed via Explicit Messaging.

Choices for Explicit Message Connections

Read Safety Controller Outputs

To perform a one-time read of one of the T>O Safety Controller output/PLC input Assembly Instances from [Outputs from the Safety Controller \(Inputs to the PLC\)](#) on page 191, use Service Type 14 (Get Attribute Single, hex 0E), Class 4, Instance 100 (0x64) or 101 (0x65) or 102 (0x66) or 103 (0x67) or 104 (0x68), Attribute 3. A successful Explicit Message of this type returns the appropriate Assembly Instance as shown in [Outputs from the Safety Controller \(Inputs to the PLC\)](#) on page 191.

See an example of this type of connection in [Read Safety Controller Outputs Example](#) on page 213.

Write Safety Controller Inputs

To perform a one-time write of the data in the Safety Controller Input (PLC Output) Assembly Instances from [Inputs to the Safety Controller \(Outputs from the PLC\)](#) on page 189, use Service Type 16 (Set Attribute Single, hex 10), Class 4, Instance 112 (0x70) or 113 (0x71) or 114 (0x72), Attribute 3. The size of the MSG Source Element (a user-defined tag array) is given by the Assembly Object in question. A successful Explicit Message of this type writes the relevant data to the Safety Controller; see [Inputs to the Safety Controller \(Outputs from the PLC\)](#) on page 189.

See an example of this type of connection in [Write Safety Controller Inputs Example](#) on page 214.



Note: Not all Safety Controllers support virtual inputs.

Virtual Output Status

To get the current status of the first 64 Virtual Outputs, use Service Type 14 (Get Attribute Single, hex 0E), Class 0x64, Instance 1, Attribute 1. A successful Explicit Message of this type returns two 32-bit integers representing the status of VO1 through VO64. See an example of this type of connection in [Read Virtual Output Status Example](#) on page 215.

Read Extended Virtual Output Status

To get the current status of all 256 Virtual Outputs, use Service Type 14 (Get Attribute Single, hex 0E), Class 0x75, Instance 1, Attribute 1. A successful Explicit Message of this type returns eight 32-bit integers containing Virtual Output status bits VO1 through VO256.

Virtual Output Fault Bits

To get the current status of the first 64 Virtual Output Fault Bits, use Service Type 14 (Get Attribute Single, hex 0E), Class 0x65, Instance 1, Attribute 1. A successful Explicit Message of this type returns two 32-bit integers representing the status of the Fault Bits for VO1 through VO64.

Read Extended Virtual Output Fault Bits

To get the current status of all 256 Virtual Output Fault Bits, use Service Type 14 (Get Attribute Single, hex 0E), Class 0x76, Instance 1, Attribute 1. A successful Explicit Message of this type returns eight 32-bit integers containing Virtual Output Fault Bits VO1 Fault through VO256 Fault.

Individual Fault Index Values

To get a specific Fault Index Value for one of the first 64 Virtual Outputs, use Service Type 14 (Get Attribute Single, hex 0E), Class 0x6F, Instance 1–64 (choose one), Attribute 1. A successful Explicit Message of this type returns a single 16-bit register representing the Fault Index value for one of the Virtual Outputs.

Read Extended Individual Fault Index Values

To get a specific Fault Index Value for one of the first 255 Virtual Outputs, use Service Type 14 (Get Attribute Single, hex 0E), Class 0x7A, Instance 1–255 (choose one), Attribute 1.

A successful Explicit Message of this type returns a 16-bit register representing the Fault Index value for one of the Virtual Outputs.

Write Virtual Inputs (On/Off Mute Enable)

To write Virtual On/Off Mute Enable bits to the Safety Controller, use Service Type 16 (Set Attribute Single, hex 10), Class 0x77, Instance 1, Attribute 1. The length of the data to be written is two 32-bit integers (8 bytes). A successful Explicit Message of this type writes Virtual On/Off Mute Enable VI1 through VI64.

Word #	Word Name	Data Type
0	Virtual Inputs VI0–15	16-bit integer
1	Virtual Inputs VI16–31	16-bit integer
2	Virtual Inputs VI32–47	16-bit integer
3	Virtual Inputs VI48–63	16-bit integer

Write Virtual Inputs (Virtual Manual Reset and Cancel Off Delay)

To write Virtual Reset/Cancel Delay bits to the Safety Controller, use Service Type 16 (Set Attribute Single, hex 10), Class 0x78, Instance 1, Attribute 1. The length of data to be written is two 32-bit integers (8 bytes). A successful Explicit Message of this type writes Virtual Reset/Cancel Delay bits VRCD1 through VRCD32 and the RCD Actuation Code.



Note: Not all Safety Controllers support virtual inputs.

Word #	Word Name	Data Type
0	VRCD (VRCD1–16) (see Virtual Manual Reset and Cancel Delay (RCD) Sequence on page 61)	16-bit integer
1	VRCD (VRCD17–32) (see Virtual Manual Reset and Cancel Delay (RCD) Sequence on page 61)	16-bit integer
2	RCD Actuation Code [RCD Enable] (see Virtual Manual Reset and Cancel Delay (RCD) Sequence on page 61)	16-bit integer
3	<i>reserved</i>	16-bit integer

Read Virtual Outputs (Virtual Manual Reset and Cancel Off Delay Feedback)

To read the status of Virtual Output bits related to the Virtual Manual Reset and Cancel Off Delay Feedback from the Safety Controller, use Service Type 14 (Get Attribute Single, hex 0E), Class 0x79, Instance 1, Attribute 1.

A successful Explicit Message of this type returns two 32-bit integers containing Virtual Reset/Cancel Delay Feedback bits VRCD Feedback 1 through VRCD Feedback 32 and the RCD Actuation Code Feedback.



Note: Not all Safety Controllers support virtual inputs.

Word #	Word Name	Data Type
0	VRCD Feedback (VRCD1–16) (see Virtual Manual Reset and Cancel Delay (RCD) Sequence on page 61)	16-bit integer

Word #	Word Name	Data Type
1	VRCD Feedback (VRCD17–32) (see Virtual Manual Reset and Cancel Delay (RCD) Sequence on page 61)	16-bit integer
2	RCD Actuation Code Feedback [RCD Enable Feedback] (see Virtual Manual Reset and Cancel Delay (RCD) Sequence on page 61)	16-bit integer
3	<i>reserved</i>	16-bit integer

Write ISD Request

To write a request for ISD device information to the Safety Controller, use Service Type 16 (Set Attribute Single, hex 10), Class 0x81, Instance 1, Attribute 1. The length of the data to be written is three 16-bit integers (6 bytes). A successful Explicit Message of this type writes the ISD Request to the Safety Controller.



Note: Not all Safety Controllers support ISD.

Word #	Word Name	Data Type
0	ISD Read Request (see Request Performance and Status Information about an Individual Device via ISD on page 50)	16-bit integer
1	ISD Chain Requested (see Request Performance and Status Information about an Individual Device via ISD on page 50)	16-bit integer
2	ISD Device Requested (see Request Performance and Status Information about an Individual Device via ISD on page 50)	16-bit integer

Read ISD Response (SC10-2 or XS26-ISD, up to 2 ISD Chains)

This Explicit Message can be used by both the SC10-2 and XS26-ISD safety controllers.

To read the Safety Controller's Response to an ISD Request (see [Write ISD Request](#) on page 209), use Service Type 14 (Get Attribute Single, hex 0E), Class 0x80, Instance 1, Attribute 1. A successful Explicit Message of this type returns 77 words containing the information shown below.



Note:

- Not all Safety Controllers support ISD.
- The ISD data is not immediately available upon power up. The ISD data can be delayed up to 10 seconds after the system power has been turned on.

Word #	Word Name	Data Type
0–1	ISD System Status – Chain 1 Device Count	32-bit integer
2–3	ISD System Status – Chain 2 Device Count	32-bit integer
4–5	ISD System Status – Chain 1 Device On/Off Status (see ISD System Status Words on page 206)	32-bit integer
6–7	ISD System Status – Chain 2 Device On/Off Status (see ISD System Status Words on page 206)	32-bit integer
8–9	ISD System Status – Chain 1 Fault Status (see ISD System Status Words on page 206)	32-bit integer
10–11	ISD System Status – Chain 2 Fault Status (see ISD System Status Words on page 206)	32-bit integer
12–13	ISD System Status – Chain 1 Marginal Status (see ISD System Status Words on page 206)	32-bit integer
14–15	ISD System Status – Chain 2 Marginal Status (see ISD System Status Words on page 206)	32-bit integer
16–17	ISD System Status – Chain 1 Alert Status (see ISD System Status Words on page 206)	32-bit integer

Word #	Word Name	Data Type
18–19	ISD System Status – Chain 2 Alert Status (see ISD System Status Words on page 206)	32-bit integer
20–21	ISD System Status – Chain 1 Reset Status (see ISD System Status Words on page 206)	32-bit integer
22–23	ISD System Status – Chain 2 Reset Status (see ISD System Status Words on page 206)	32-bit integer
24–25	ISD System Status – Chain 1 Actuator Recognized (see ISD System Status Words on page 206)	32-bit integer
26–27	ISD System Status – Chain 2 Actuator Recognized (see ISD System Status Words on page 206)	32-bit integer
28–29	ISD System Status – Chain 1 System Status (see ISD Chain System Status on page 50)	32-bit integer
30–31	ISD System Status – Chain 2 System Status (see ISD Chain System Status on page 50)	32-bit integer
32–47	List of Detected ISD Devices on a Chain	Array of 32 bytes
48–64	<i>reserved</i>	16-bit integer
65	ISD Read Request Acknowledge (see Request Performance and Status Information about an Individual Device via ISD on page 50)	16-bit integer
66	ISD Chain Requested Acknowledge (see Request Performance and Status Information about an Individual Device via ISD on page 50)	16-bit integer
67	ISD Device Requested Acknowledge (see Request Performance and Status Information about an Individual Device via ISD on page 50)	16-bit integer
68–76	ISD Individual Device-Specific Data (see ISD Individual Device-Specific Data Detailed Description on page 202)	16-bit integer

Read ISD Response (XS26-ISD Models only, up to 8 ISD Chains)

This Explicit Message is used only by the XS26-ISD safety controller.

To read the Safety Controller's Response to an ISD Request (see [Write ISD Request](#) on page 209), use Service Type 14 (Get Attribute Single, hex 0E), Class 0x82, Instance 1, Attribute 1. A successful Explicit Message of this type returns 128 words containing the information shown below.



Note:

- Not all Safety Controllers support ISD.
- Only the XS26-ISD supports eight chains of ISD devices.
- The ISD data is not immediately available upon power up. The ISD data can be delayed up to 10 seconds after the system power has been turned on.

Word #	Word Name	Data Type
0-1	ISD System Status – Chain 1 Device Count	32-bit integer
2-3	ISD System Status – Chain 1 Device On/Off Status	32-bit integer
4-5	ISD System Status – Chain 1 Fault Status	32-bit integer
6-7	ISD System Status – Chain 1 Marginal Status	32-bit integer
8-9	ISD System Status – Chain 1 Alert Status	32-bit integer
10-11	ISD System Status – Chain 1 Reset Status	32-bit integer
12-13	ISD System Status – Chain 1 Actuator Recognized Status	32-bit integer
14-15	ISD System Status – Chain 1 System Status	32-bit integer
16-17	ISD System Status – Chain 2 Device Count	32-bit integer

Word #	Word Name	Data Type
18-19	ISD System Status – Chain 2 Device On/Off Status	32-bit integer
20-21	ISD System Status – Chain 2 Fault Status	32-bit integer
22-23	ISD System Status – Chain 2 Marginal Status	32-bit integer
24-25	ISD System Status – Chain 2 Alert Status	32-bit integer
26-27	ISD System Status – Chain 2 Reset Status	32-bit integer
28-29	ISD System Status – Chain 2 Actuator Recognized Status	32-bit integer
30-31	ISD System Status – Chain 2 System Status	32-bit integer
32-33	ISD System Status – Chain 3 Device Count	32-bit integer
34-35	ISD System Status – Chain 3 Device On/Off Status	32-bit integer
36-37	ISD System Status – Chain 3 Fault Status	32-bit integer
38-39	ISD System Status – Chain 3 Marginal Status	32-bit integer
40-41	ISD System Status – Chain 3 Alert Status	32-bit integer
42-43	ISD System Status – Chain 3 Reset Status	32-bit integer
44-45	ISD System Status – Chain 3 Actuator Recognized Status	32-bit integer
46-47	ISD System Status – Chain 3 System Status	32-bit integer
48-49	ISD System Status – Chain 4 Device Count	32-bit integer
50-51	ISD System Status – Chain 4 Device On/Off Status	32-bit integer
52-53	ISD System Status – Chain 4 Fault Status	32-bit integer
54-55	ISD System Status – Chain 4 Marginal Status	32-bit integer
56-57	ISD System Status – Chain 4 Alert Status	32-bit integer
58-59	ISD System Status – Chain 4 Reset Status	32-bit integer
60-61	ISD System Status – Chain 4 Actuator Recognized Status	32-bit integer
62-63	ISD System Status – Chain 4 System Status	32-bit integer
64-65	ISD System Status – Chain 5 Device Count	32-bit integer
66-67	ISD System Status – Chain 5 Device On/Off Status	32-bit integer
68-69	ISD System Status – Chain 5 Fault Status	32-bit integer
70-71	ISD System Status – Chain 5 Marginal Status	32-bit integer
72-73	ISD System Status – Chain 5 Alert Status	32-bit integer
74-75	ISD System Status – Chain 5 Reset Status	32-bit integer
76-77	ISD System Status – Chain 5 Actuator Recognized Status	32-bit integer
78-79	ISD System Status – Chain 5 System Status	32-bit integer
80-81	ISD System Status – Chain 6 Device Count	32-bit integer
82-83	ISD System Status – Chain 6 Device On/Off Status	32-bit integer
84-85	ISD System Status – Chain 6 Fault Status	32-bit integer
86-87	ISD System Status – Chain 6 Marginal Status	32-bit integer
88-89	ISD System Status – Chain 6 Alert Status	32-bit integer
90-91	ISD System Status – Chain 6 Reset Status	32-bit integer
92-93	ISD System Status – Chain 6 Actuator Recognized Status	32-bit integer
94-95	ISD System Status – Chain 6 System Status	32-bit integer
96-97	ISD System Status – Chain 7 Device Count	32-bit integer

Word #	Word Name	Data Type
98-99	ISD System Status – Chain 7 Device On/Off Status	32-bit integer
100-101	ISD System Status – Chain 7 Fault Status	32-bit integer
102-103	ISD System Status – Chain 7 Marginal Status	32-bit integer
104-105	ISD System Status – Chain 7 Alert Status	32-bit integer
106-107	ISD System Status – Chain 7 Reset Status	32-bit integer
108-109	ISD System Status – Chain 7 Actuator Recognized Status	32-bit integer
110-111	ISD System Status – Chain 7 System Status	32-bit integer
112-113	ISD System Status – Chain 8 Device Count	32-bit integer
114-115	ISD System Status – Chain 8 Device On/Off Status	32-bit integer
116-117	ISD System Status – Chain 8 Fault Status	32-bit integer
118-119	ISD System Status – Chain 8 Marginal Status	32-bit integer
120-121	ISD System Status – Chain 8 Alert Status	32-bit integer
122-123	ISD System Status – Chain 8 Reset Status	32-bit integer
124-125	ISD System Status – Chain 8 Actuator Recognized Status	32-bit integer
126-127	ISD System Status – Chain 8 System Status	32-bit integer

Individual Fault Log Entry

To get a specific entry from the 10 entry Fault Log, use Service Type 14 (Get Attribute Single, hex 0E), Class 0x71, Instance 1, Attribute 1–10 (choose one). A successful Explicit Message of this type will return a single 15 register entry from the fault log, as defined below. Note that Attribute = 1 references the most recent entry in the error log, while Attribute = 10 is the oldest entry.

Word #	Word Name	Data Type
0–1	Fault #1 Time Stamp	32-bit integer
2–9	Fault #1 Name of I/O or System	2-word length + 12-ASCII characters
10	Fault #1 Error Code	16-bit integer
11	Fault #1 Advanced Error Code	16-bit integer
12	Fault #1 Error Message Index	16-bit integer
13–14	<i>reserved</i>	16-bit integer

System Information

Some system information can be accessed using Service Type 14 (Get Attribute Single, hex 0E), Class 0x72, Instance 1, Attribute 1–4 (choose one, see the following table). A successful Explicit Message of this type returns the system information seen below (size and data type vary). See an example of this type of connection in [Read System Information Example](#) on page 216.

Attribute	System Value	Data Type
1	Seconds Since Boot	32-bit integer
2	Operating Mode	16-bit integer
3	ConfigName	2-word length + 16-ASCII characters
4	Config CRC	32-bit integer

Examples of Explicit Message Connections

Read Safety Controller Outputs Example

To perform a one-time read of the 100 (0x64) Assembly Instance, use Service Type 14 (Get Attribute Single, hex 0E), Class 4, Instance 100, Attribute 3. A successful Explicit Message of this type will return all 8 registers of the 100 (0x64) Assembly Instance, as defined in [Configuration Assembly Object](#) on page 203.

The following figure shows the MSG command for this explicit message.

Figure 208. MSG Command—Configuration Tab

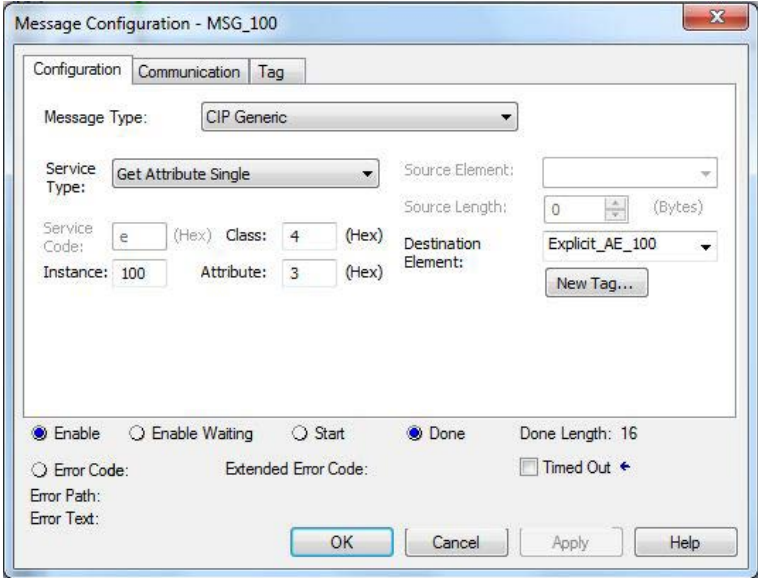
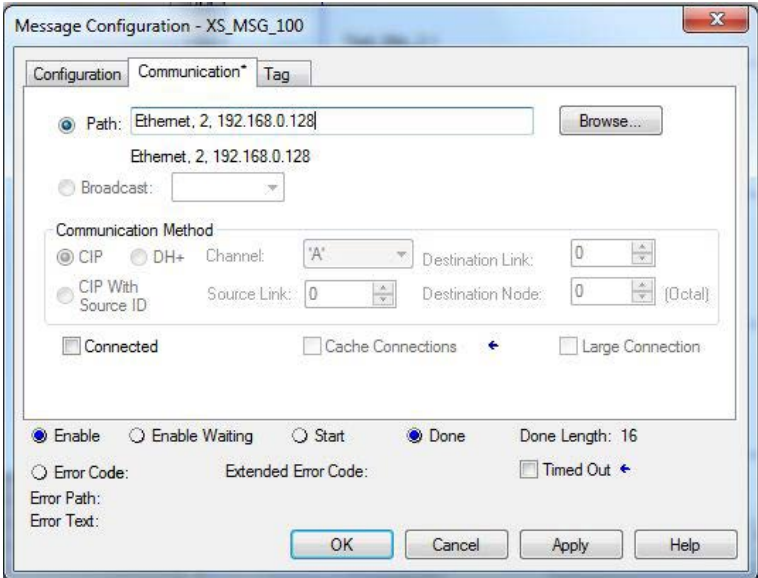

Figure 209. MSG Command—Communication Tab



The following figure shows the user-defined array (called XS_Explicit_AE_100) showing all 8 registers.

Figure 210. User-Defined Array

- XS_Explicit_AE_100	{...}	{...}	Decimal	INT[8]
+ XS_Explicit_AE_100[0]	2		Decimal	INT
+ XS_Explicit_AE_100[1]	0		Decimal	INT
+ XS_Explicit_AE_100[2]	0		Decimal	INT
+ XS_Explicit_AE_100[3]	0		Decimal	INT
+ XS_Explicit_AE_100[4]	0		Decimal	INT
+ XS_Explicit_AE_100[5]	0		Decimal	INT
+ XS_Explicit_AE_100[6]	0		Decimal	INT
+ XS_Explicit_AE_100[7]	0		Decimal	INT

In this example data, we can see that VO2 is currently ON. VO2 is word 0, bit $1 > 2^1 = 2$

Write Safety Controller Inputs Example

To perform a one-time write of the data in the Safety Controller Input (PLC Output) Assembly Instance 112 (0x70), use Service Type 16 (Set Attribute Single, hex 10), Class 4, Instance 112 (0x70), Attribute 3. The size of the MSG Source Element (a user-defined tag array) is 4 bytes in this case.

The following figure shows the user-defined array (called AE112) to be written to the Safety Controller.

Figure 211. User-Defined Array to be Written to the Safety Controller

▲ AE112	{...}	{...}	Decimal	INT[2]
▶ AE112[0]	7		Decimal	INT
▶ AE112[1]	0		Decimal	INT

The following figure shows the MSG command for this explicit message.

Figure 212. MSG Command—Configuration Tab

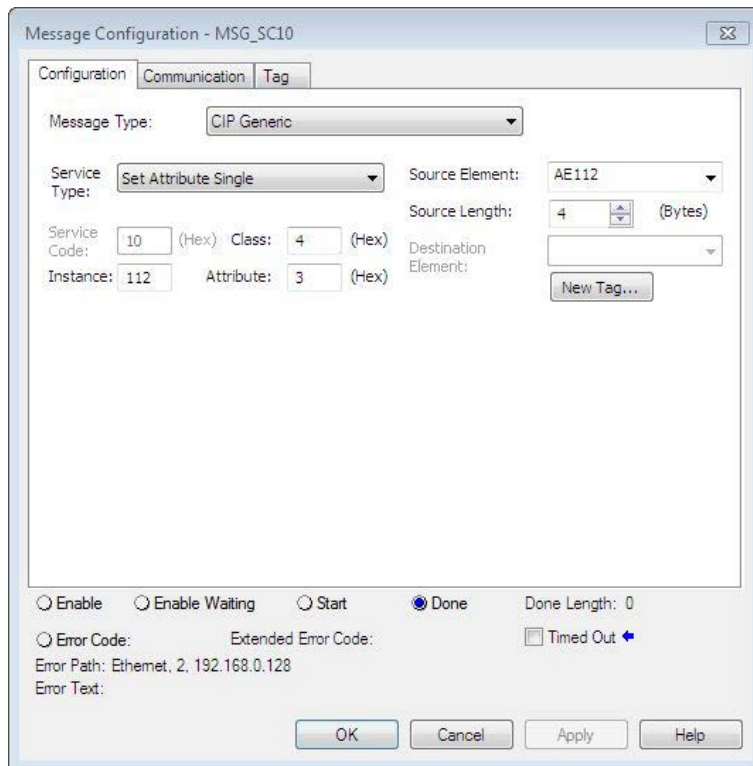
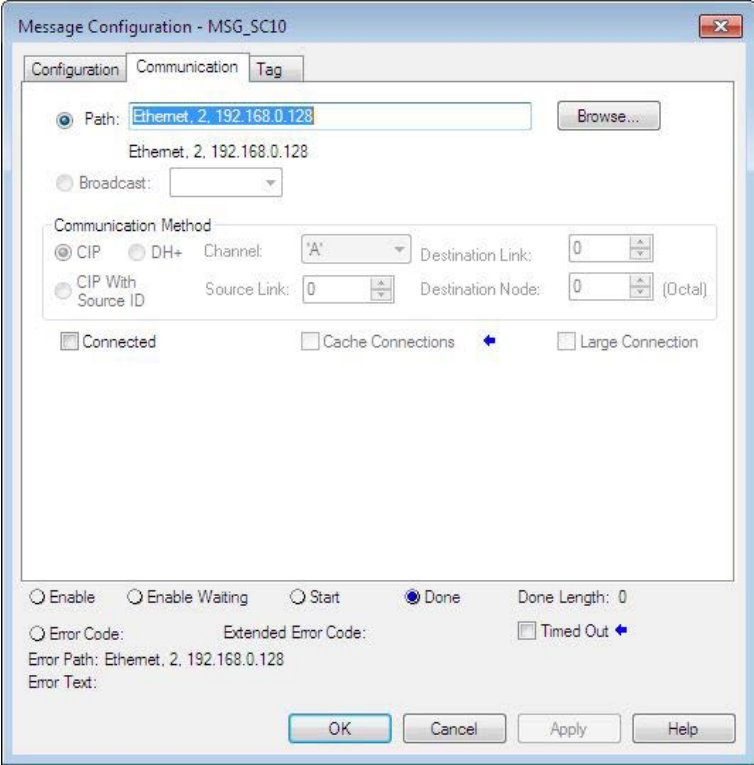

Figure 213. MSG Command—Communication Tab



Read Virtual Output Status Example

To perform a one-time read of the current status of the first 64 Virtual Outputs, use Service Type 14 (Get Attribute Single, hex 0E), Class 0x64, Instance 1, Attribute 1. A successful Explicit Message of this type returns two 32-bit integers representing the status of VO1 through VO64.

The following figure shows the MSG command for this explicit message.

Figure 214. MSG Command—Configuration Tab

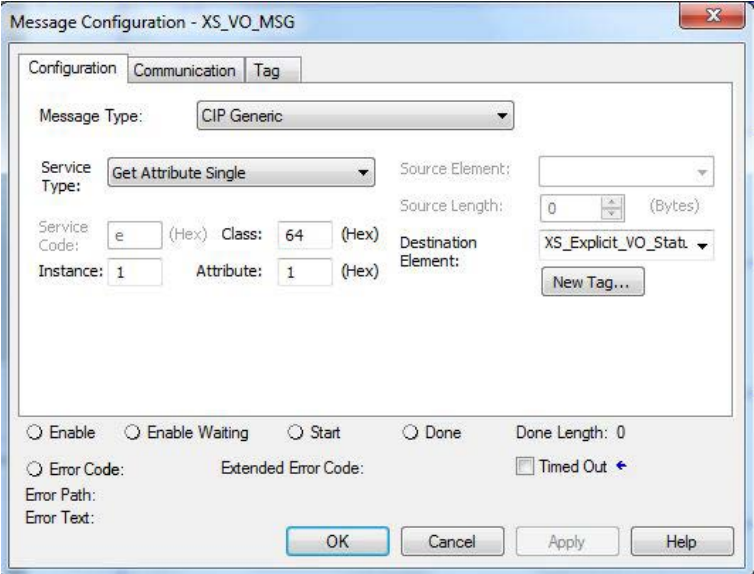
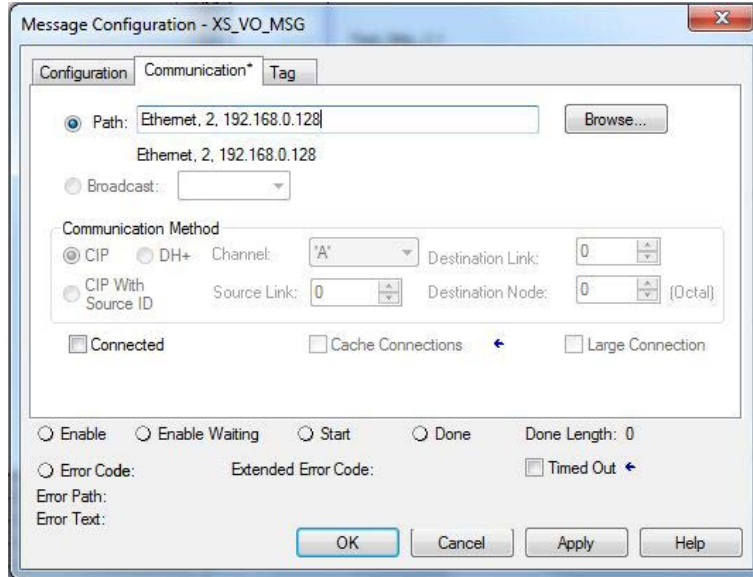

Figure 215. MSG Command—Communication Tab



The following figure shows the user-defined array (called XS_Explicit_VO_Status) showing two 32-bit integers.

Figure 216. User-Defined Array

[-] XS_Explicit_VO_Status	{...}	{...}	Decimal	DINT[2]
+ XS_Explicit_VO_Status[0]	1		Decimal	DINT
+ XS_Explicit_VO_Status[1]	0		Decimal	DINT

In this example data, we can see that VO1 is currently ON. VO1 is word 1, bit 0 > 2⁰ = 1

Read System Information Example

Some system information can be accessed using EtherNet/IP Explicit Messages. One such piece of data is the Configuration Name from the Safety Controller. To get this information, use Service Type 14 (Get Attribute Single, hex 0E), Class 0x72, Instance 1, Attribute 3. A successful Explicit Message of this type will return the 32-bit length and ASCII string comprising the Safety Controller Configuration Name.

The following figure shows the MSG command for this explicit message.

Figure 217. MSG Command—Configuration Tab

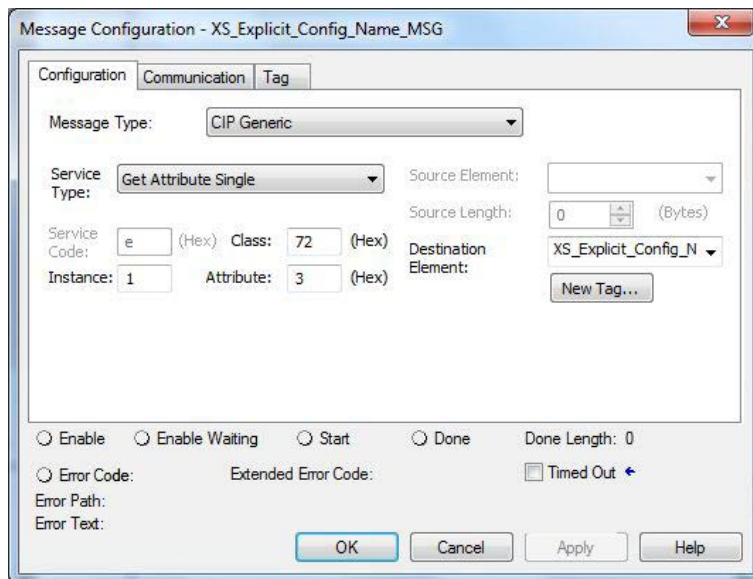
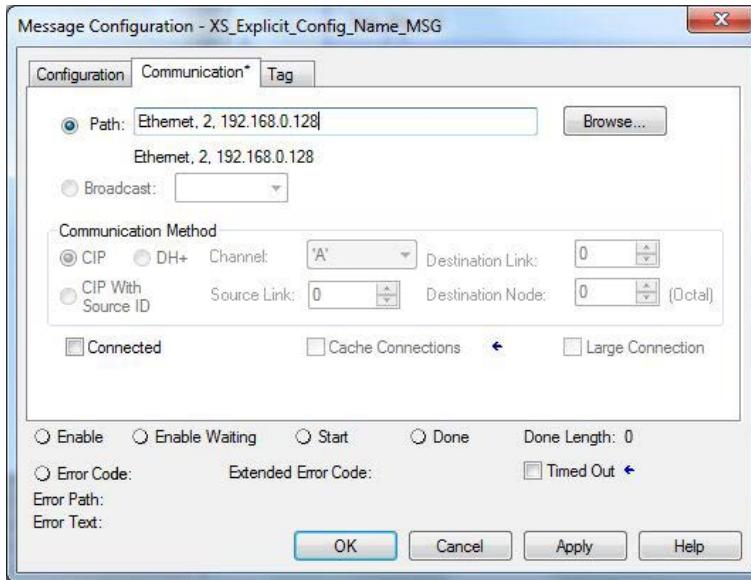

Figure 218. MSG Command—Communication Tab



The following figure shows the user-defined array (called XS_Explicit_Config_Name) showing all 8 registers.

Figure 219. User-Defined Array

[-] XS_Explicit_Config_Name	{...}	{...}	Decimal	INT[10]
+ XS_Explicit_Config_Name[0]	12		Decimal	INT
+ XS_Explicit_Config_Name[1]	0		Decimal	INT
+ XS_Explicit_Config_Name[2]	'1B'		ASCII	INT
+ XS_Explicit_Config_Name[3]	'na'		ASCII	INT
+ XS_Explicit_Config_Name[4]	'k'		ASCII	INT
+ XS_Explicit_Config_Name[5]	'oC'		ASCII	INT
+ XS_Explicit_Config_Name[6]	'fn'		ASCII	INT
+ XS_Explicit_Config_Name[7]	'gi'		ASCII	INT
+ XS_Explicit_Config_Name[8]	0		Decimal	INT
+ XS_Explicit_Config_Name[9]	0		Decimal	INT

Note that the first two registers are a 32-bit integer describing how many ASCII characters are coming in the Config Name. Here that value is 12. ASCII characters are packed, two per register, in the so-called ControlLogix String Format. The Config name here is *Blank Config*, but the ControlLogix string format displays those characters, two per line, in reverse order.

Step-by-Step Explicit Messages

Making an explicit message connection from scratch in an Allen-Bradley PLC program requires the following steps.

1. Make a new tag with the Message data type.
2. Make a new tag to act as a Destination Element (a 16-bit array large enough to hold the data that will be requested).
3. Add a MSG command to your ladder logic (using the Message tag from #1 and the Destination Element from #2). The Class, Instance, and Attribute values depend on the data desired.
4. In the Communication tab of the MSG command, enter the path to the Safety Controller: for example, `Ethernet, 2, 192.168.0.128`, where the 2 is used for EtherNet/IP connections in the PLC and the IP Address shown is that of the Safety Controller.

12.4.12 EIP on Omron PLC Configuration

The following figures show an EtherNet/IP Connection between a Safety Controller and an Omron CJ2H PLC.

1. Open the Omron Network Configurator software.

Figure 220. Omron Network Configurator Software

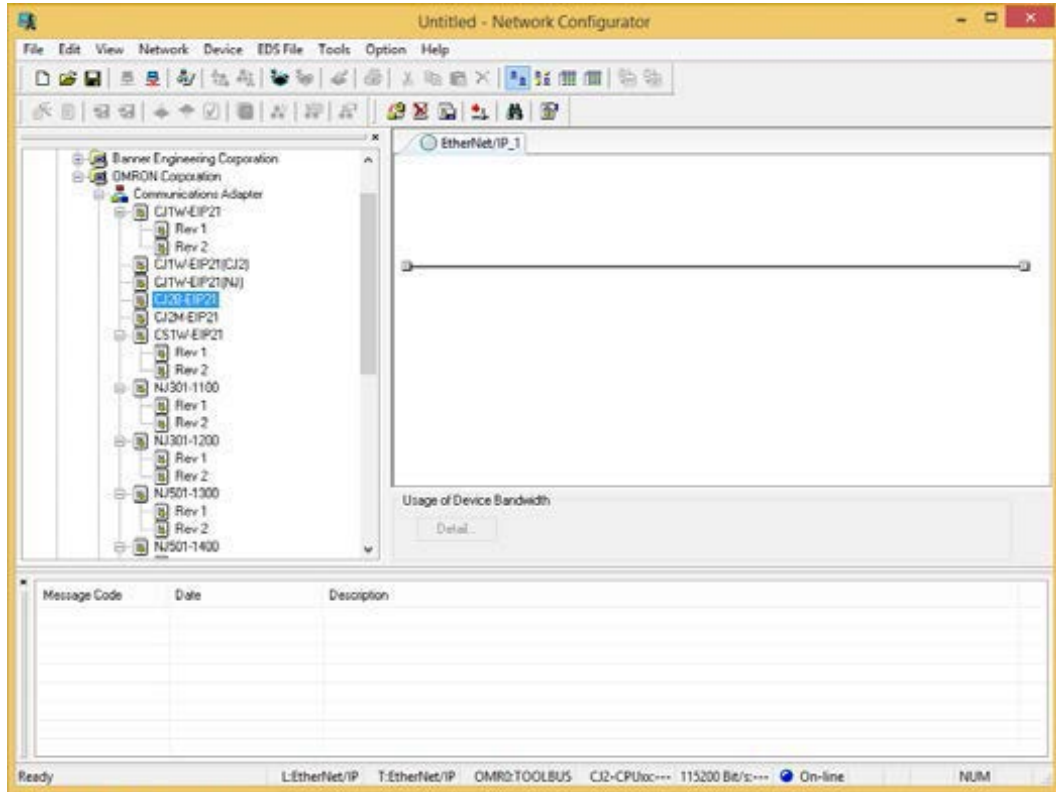

2. Add the correct PLC to the network.
3. Right click on the PLC and click **Change Node Address** to change the IP address.

Figure 221. Right-Click Menu

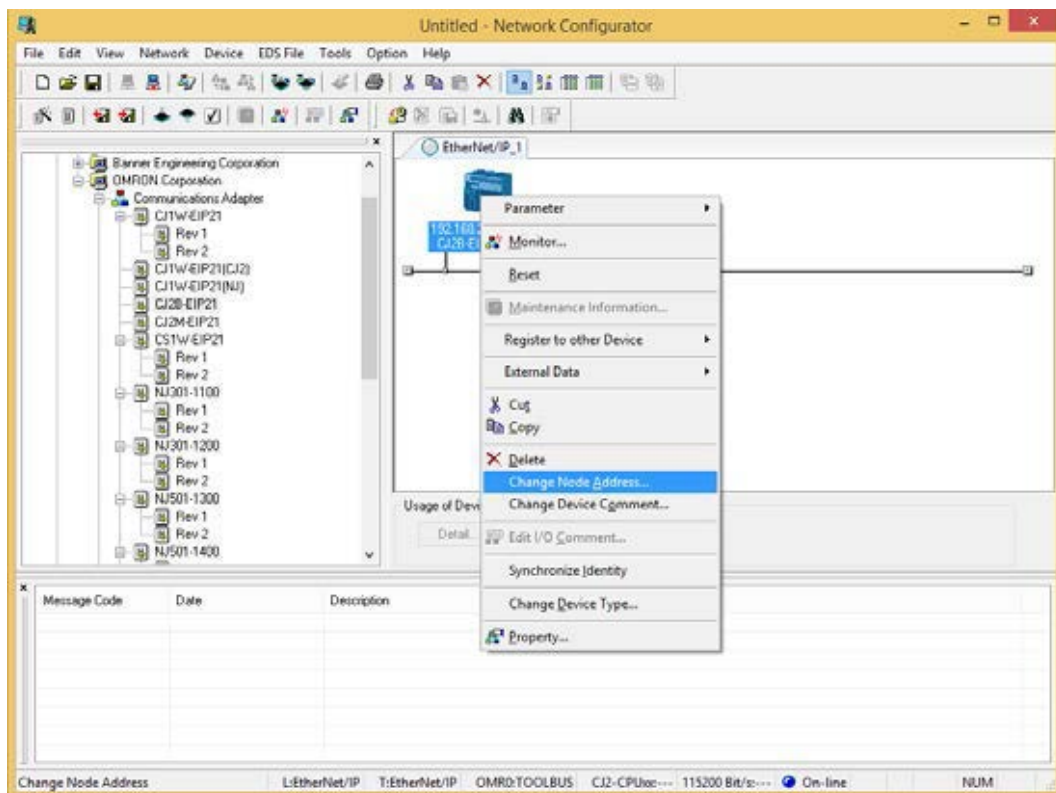

Here is the PLC's IP address:

Figure 222. PLC IP Address

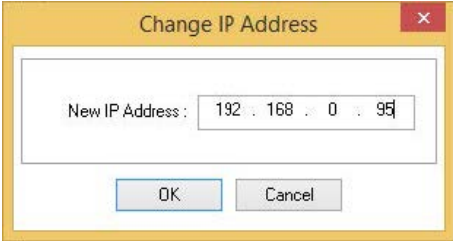

- 4. Install the Safety Controller EDS file.
 - a) Go to **EDS_File > Install**.
 - b) Browse to and select the EDS file.
 - c) Double click the new item from the list at left to add it to the network.

Figure 223. Add the Safety Controller

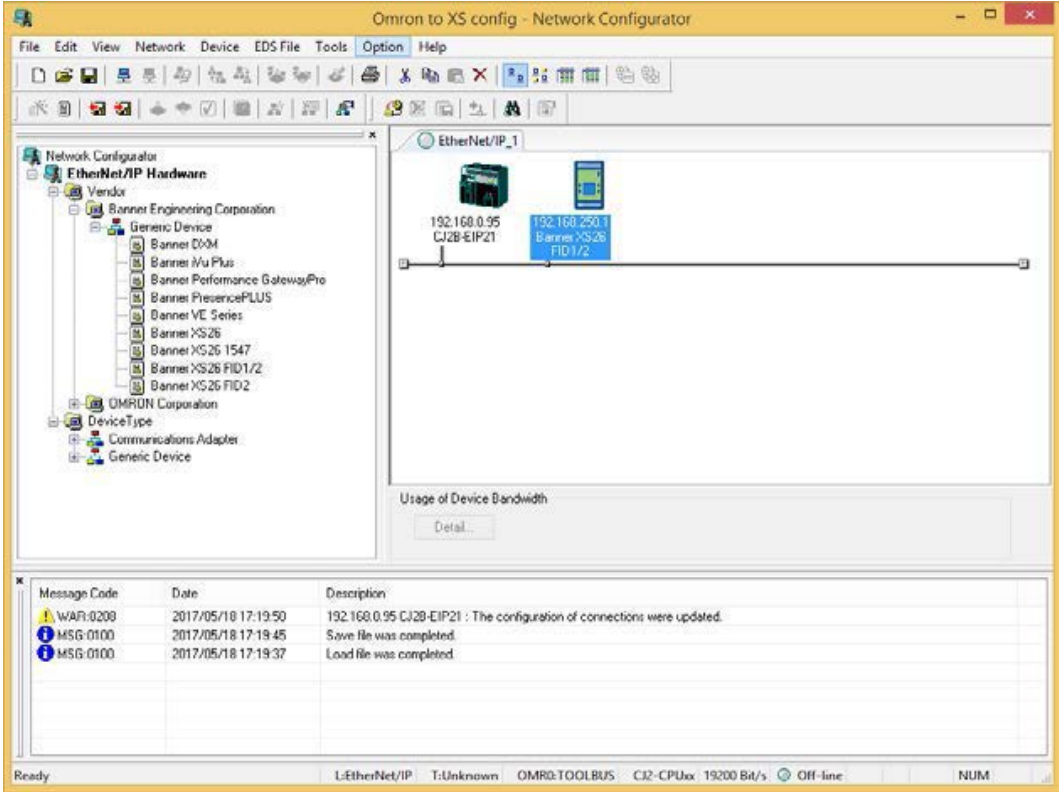

- 5. Right click on the Safety Controller, and click **Change Node Address** to change the IP address.
- 6. Enter the Safety Controller's IP address.

Figure 224. Safety Controller IP Address

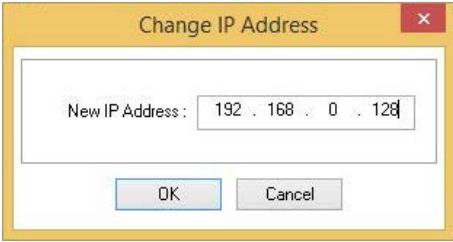

- 7. Double click on the PLC icon to edit the device parameters.
 - a) Select the Safety Controller from the **Unregister Device List**.

Figure 225. *Unregister Device List*

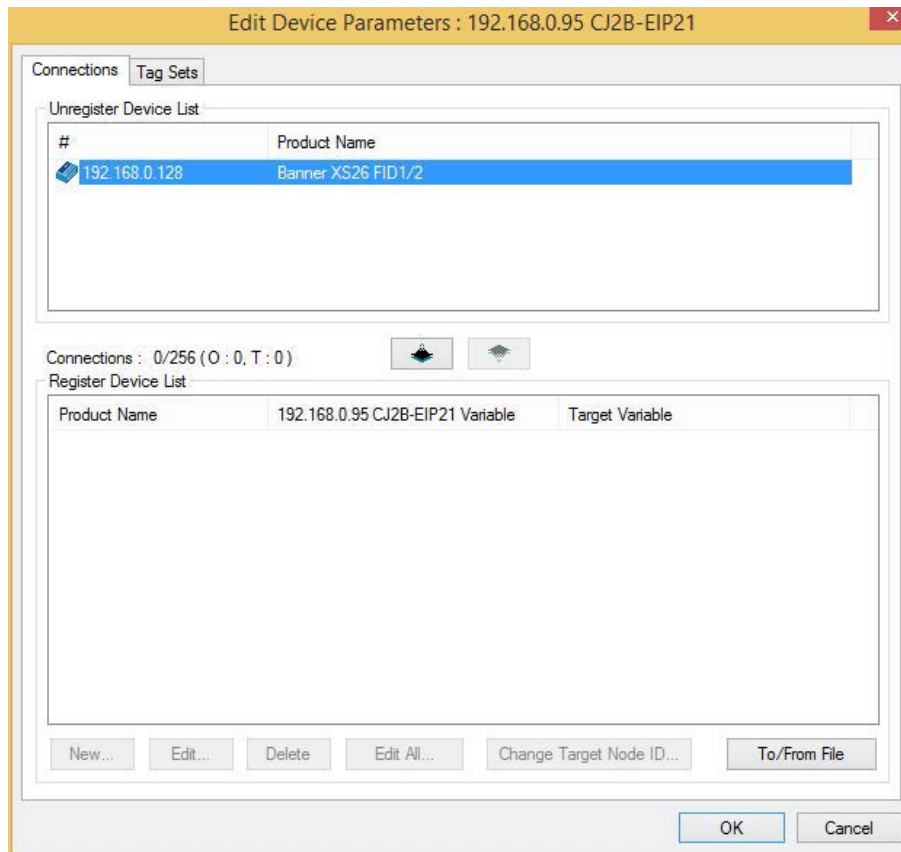

b) Click the down arrow to send it to the **Register Device List**.

Figure 226. *Register Device List*

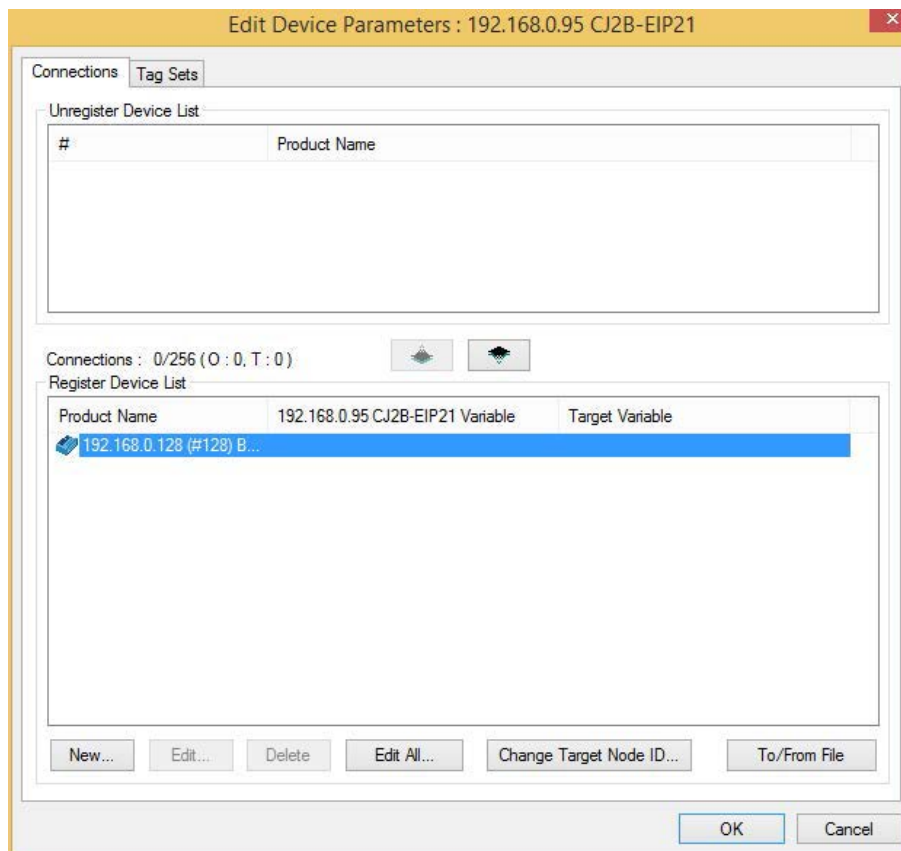

c) Click the **Tag Sets** tab (to see the window below).

Figure 227. *Tag Sets Tab*

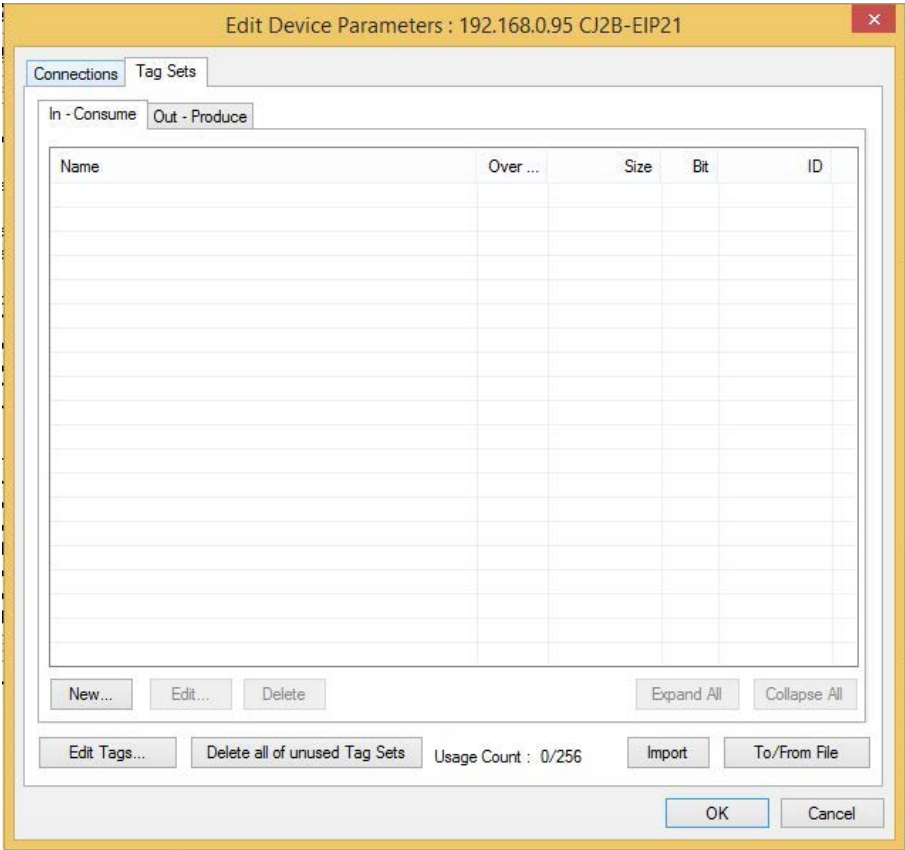

- d) Click **Edit Tags...**.
The **Edit Tags** window displays.
- e) Click on the **In - Consume** tab.

Figure 228. *Edit Tag Window—In - Consume Tab*

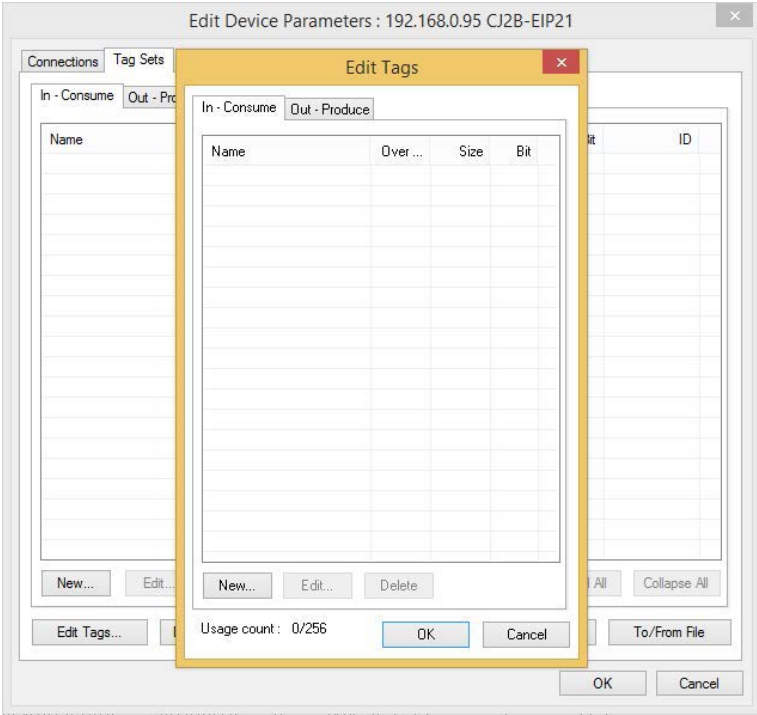

f) Click **New**.

The **Edit Tag** window displays.

g) Select an appropriate type and size CPU Data Area.

In this example, the Safety Controller will be sending out 16-bit words, so the DM area works. Choose a **Size** (number of bytes) equal to the desired EIP assembly instance. Here we are looking at *In - Consume* (from the PLC's point of view), which is the T > O assemblies. See [Inputs to the Safety Controller \(Outputs from the PLC\)](#) on page 189 and [Outputs from the Safety Controller \(Inputs to the PLC\)](#) on page 191 for more information on the assembly objects. The choices are:

- VO Status/Fault - 100 (0×64), size 16 bytes
- Fault Index Words - 101 (0×65), size 208 bytes
- Error Log Only - 102 (0×66), size 300 bytes
- Reset/Cancel Delay - 103 (0×67), size 70 bytes
- VRCD plus ISD - 104 (0×68), size 224 bytes
- 8 ISD Chains - 105 (0×69), size 480 bytes

Figure 229. *Edit Tag* Window

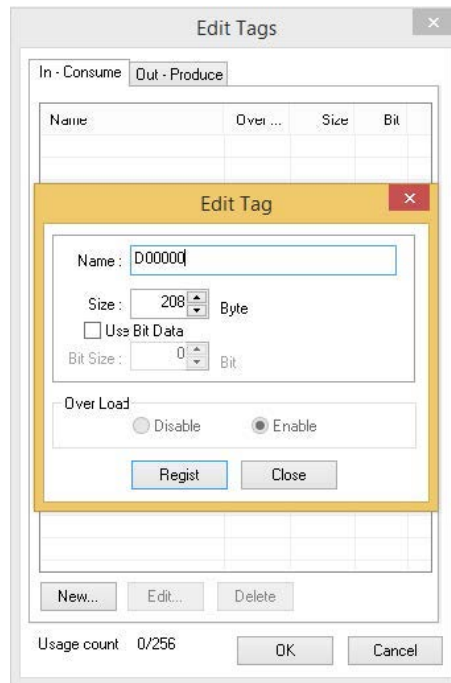

h) After entering the **Name** (remember that this refers to a CPU Data Area on the PLC) and **Size** in bytes, click **Register**, then click **Close**.

i) Click on the **Out- Produce** tab.

Figure 230. Out- Produce Tab

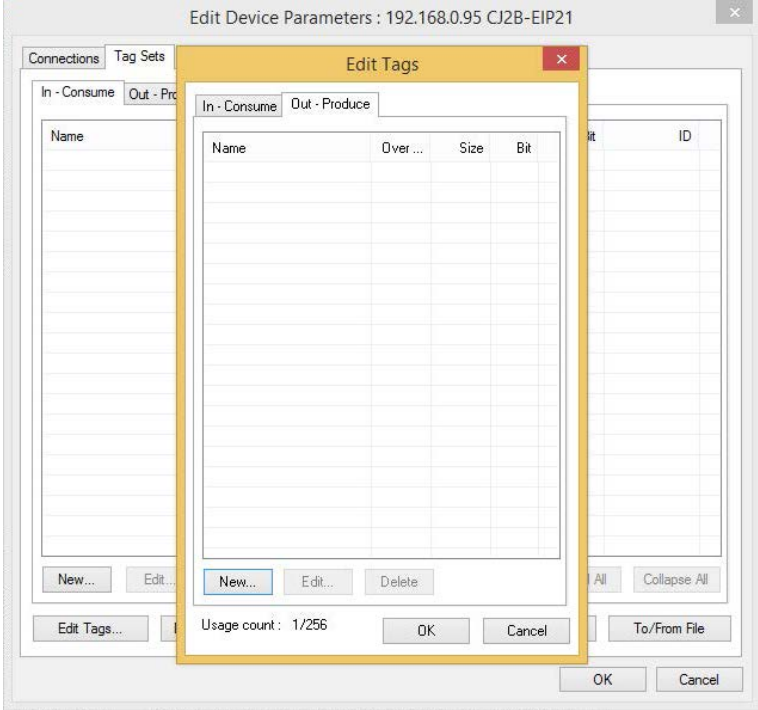

- j) Click **New**.
 - k) Choose an appropriate type and size CPU Data Area.
- The choices are:

- 112 (0x70), size 2 bytes (no data in these registers)
- 113 (0x71), size 22 bytes (virtual reset, cancel delay bits)
- 114 (0x72), size 28 bytes (8 ISD chains)

Figure 231. Edit Tag Window

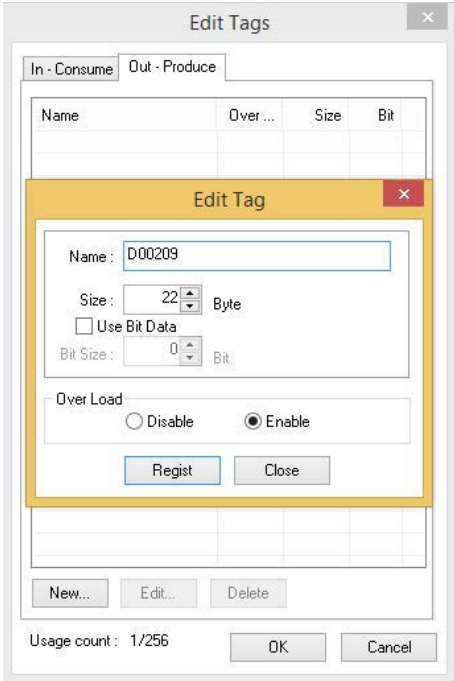

- l) After entering the **Name** (remember that this refers to a CPU Data Area on the PLC) and **Size** in bytes, click **Regist**, then click **Close**.
- m) On the **Edit Tags** window, click **OK**.
The message "The new Tags will be registered as Tag sets" displays.

- n) Click **Yes**.
- 8. Double check the tags by clicking on both the **In- Consume** and **Out- Produce** tabs.

Figure 232. **In- Consume** Tab

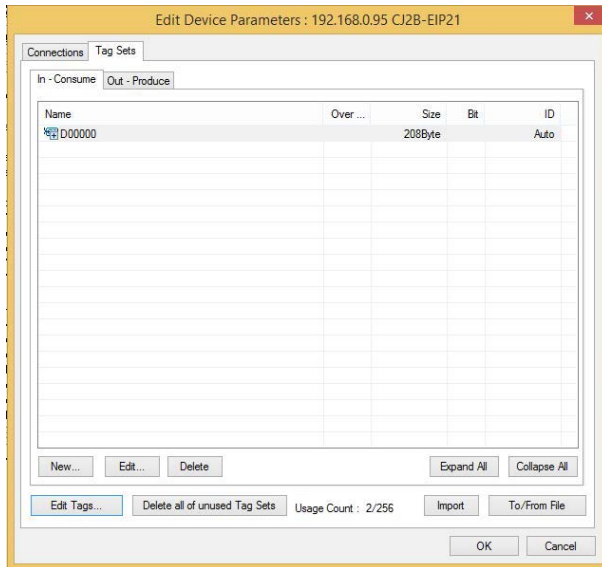
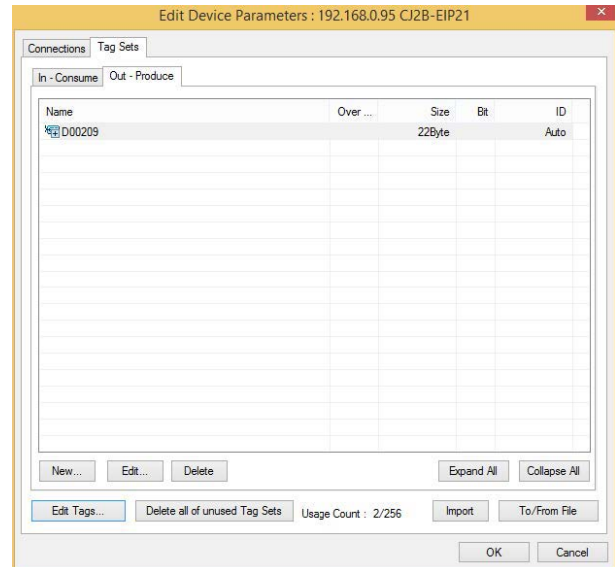
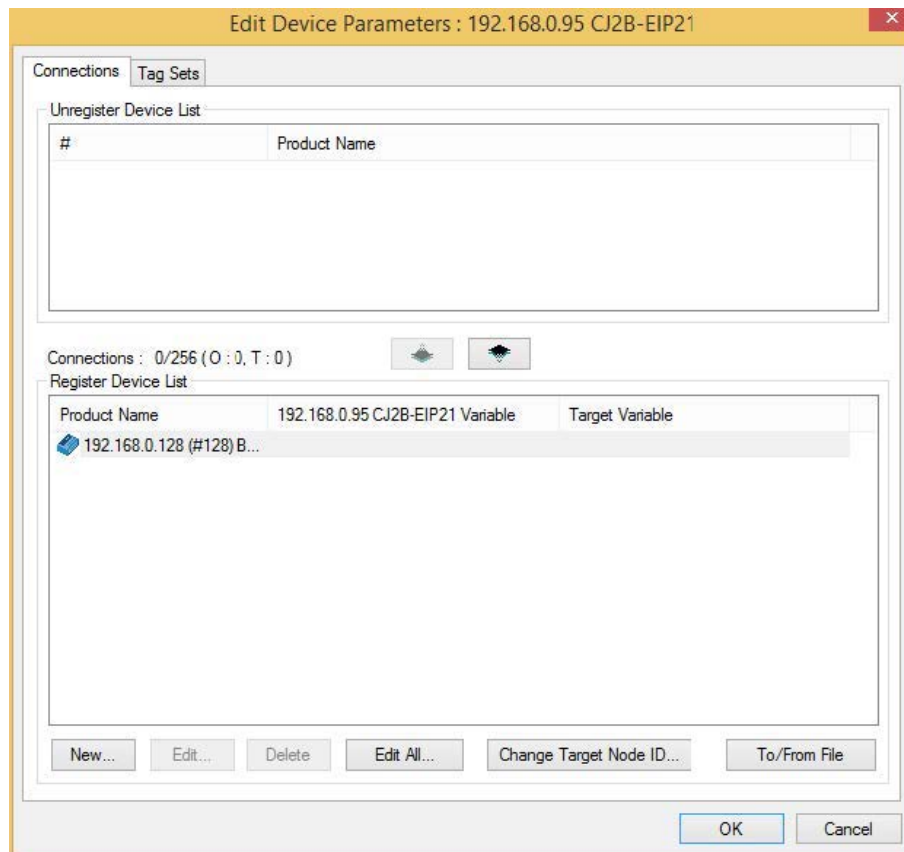

Figure 233. **Out- Produce** Tab



- 9. Go back to the **Connections** tab (to see the window below).

Figure 234. **Edit Device Parameters Window—Connections** Tab



- 10. Double click on the Safety Controller seen in the **Register Device List**.
The **Edit Connection** window opens.
- 11. Select the appropriate **Connections** and **RPI**.

Figure 235. Edit Connections

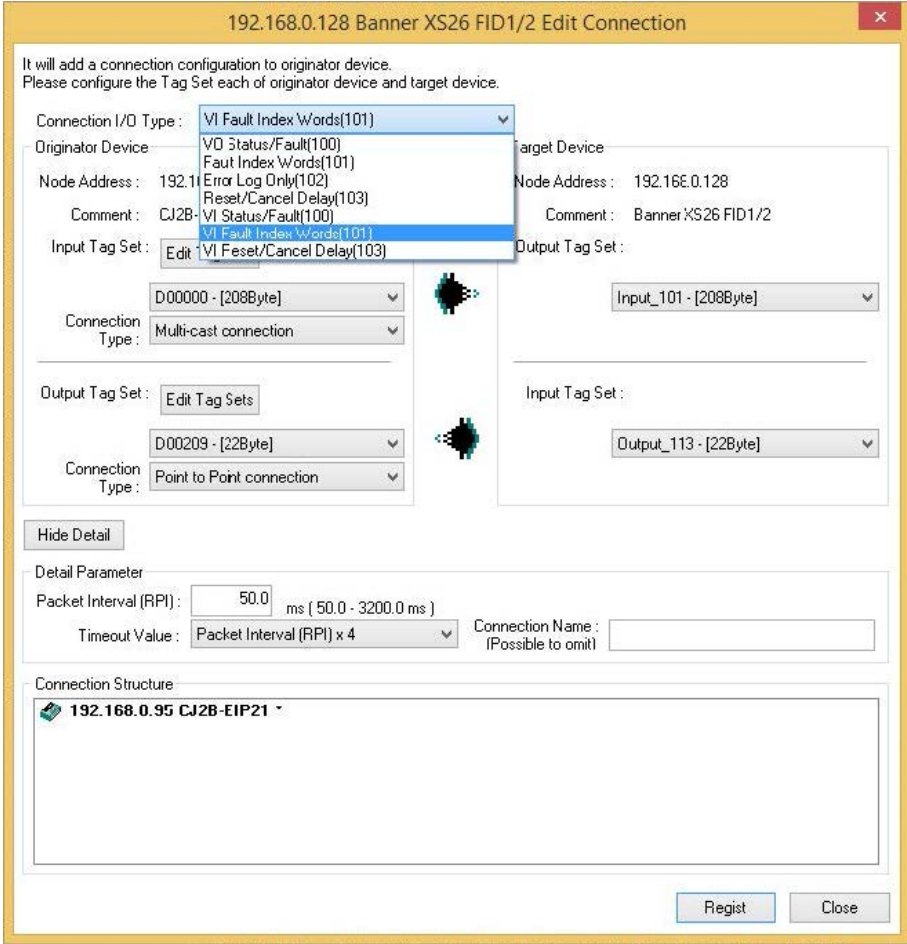

- 12. Click **Register**, then click **Close**.
- 13. Click **OK** on the **Edit Parameters** window.

Figure 236. Edit Parameters Window

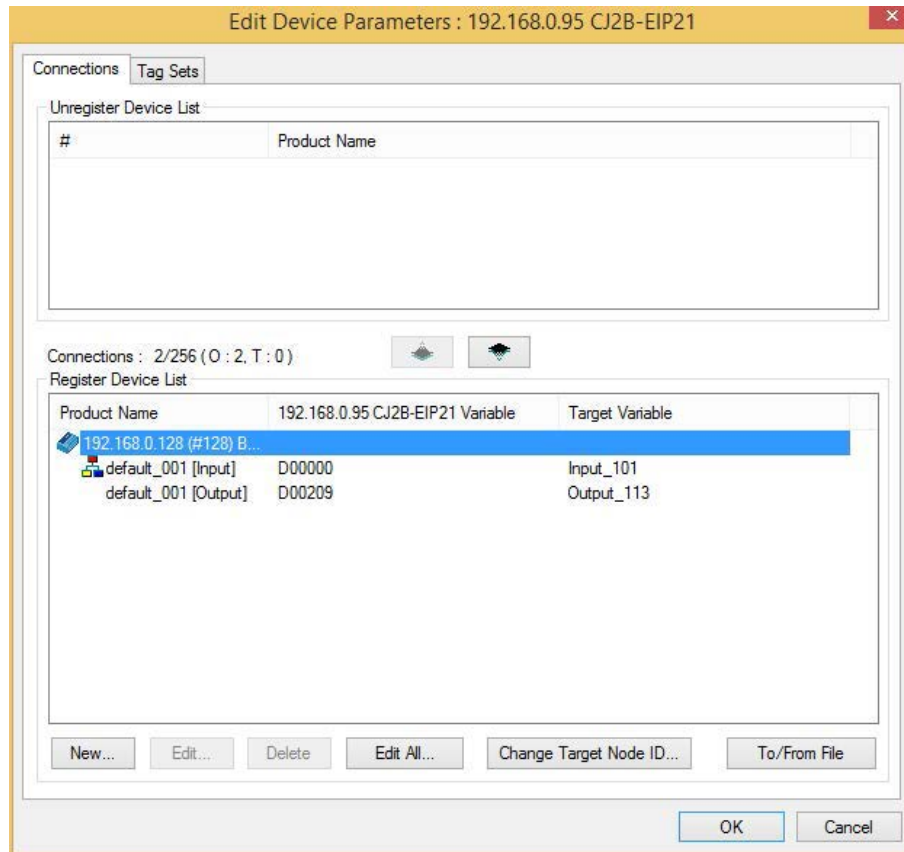

14. Go online and download the configuration to the PLC.

Figure 237. Download the Configuration

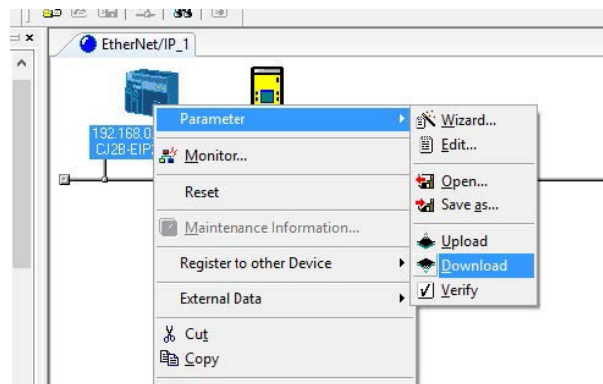

15. On the "Downloading parameters to selected devices will start" message, click **Yes**.

16. Select a download option.

Figure 238. Download Options

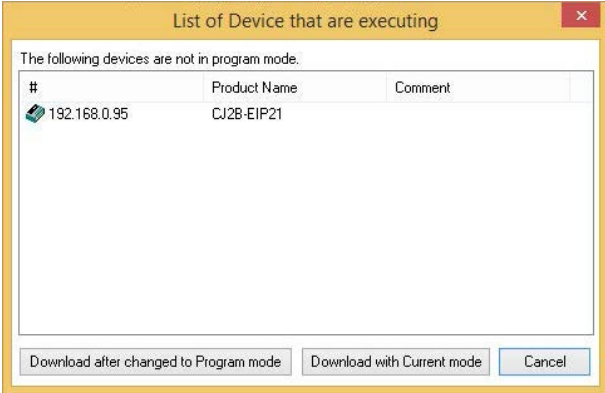

- 17. Click **Yes** on the "Controller's mode will be returned to the state before starting download" message, then click **OK** on the "Download of device parameter was completed" message.
- 18. Right click on the PLC icon and select **Monitor**.
This window shows whether the connection looks good. Blue icons indicate a connection is running fine and without errors.

Figure 239. Monitor Device Window—Status 1 Tab

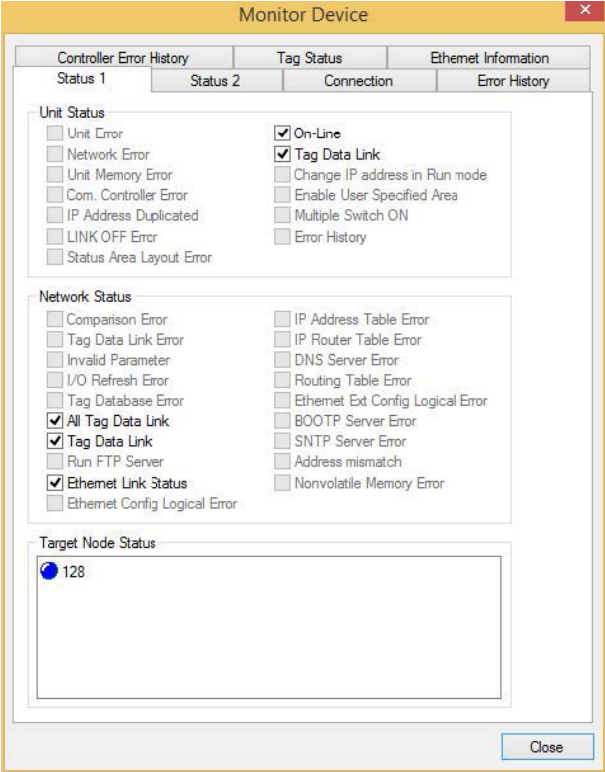
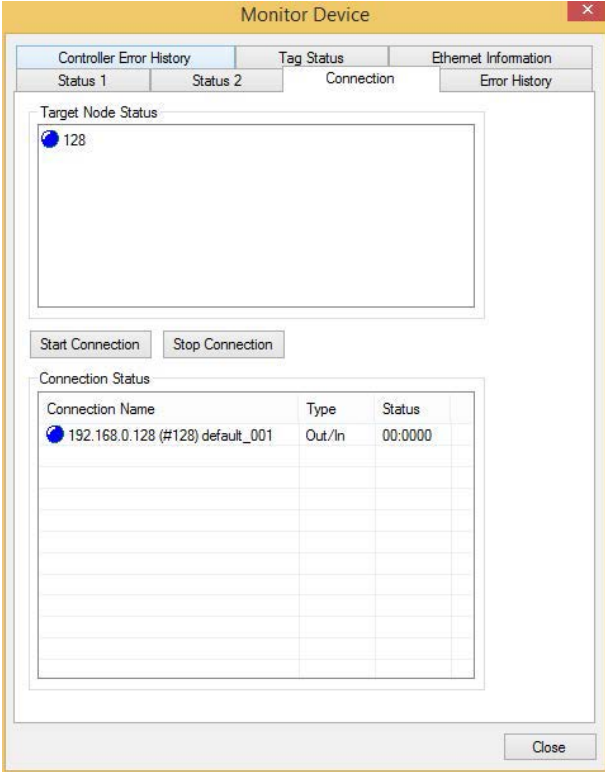
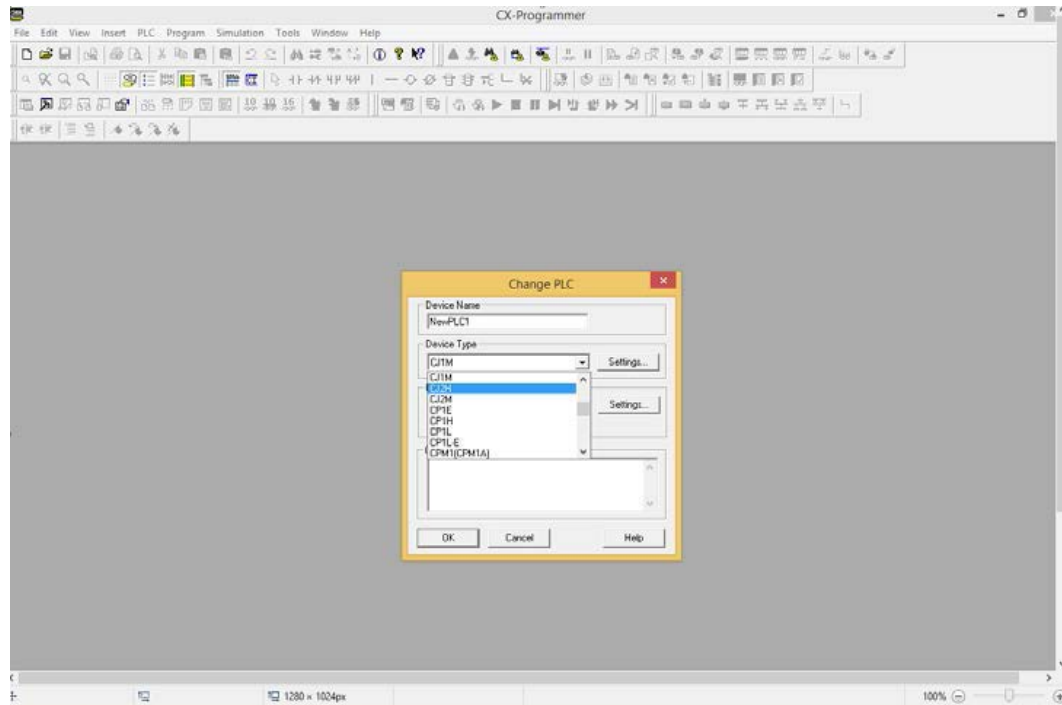

Figure 240. Monitor Device Window—Connection Tab



- 19. Open the CX Programmer software.
- 20. Go to **File > New**.
The **Change PLC** window displays.
- 21. Select a PLC model, then click **Settings**.

Figure 241. Change PLC Window



22. Select a **CPU Type** and click **OK**.

Figure 242. Device Type Settings Window

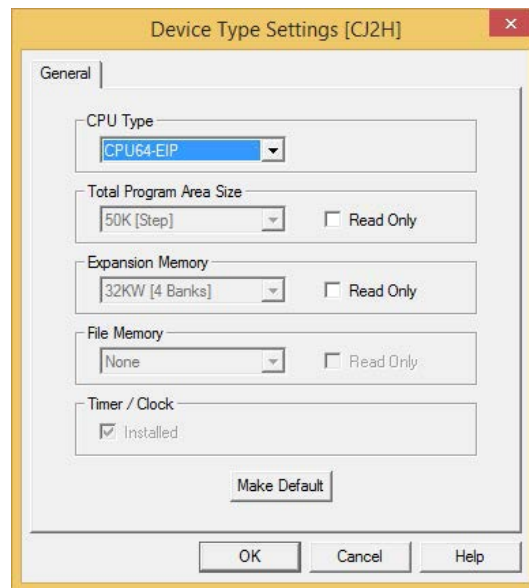

23. Select a **Network Type** and click **OK**.

Figure 243. Change PLC Window



24. Go Online with the PLC; click **Work Online**.

Figure 244. Work Online

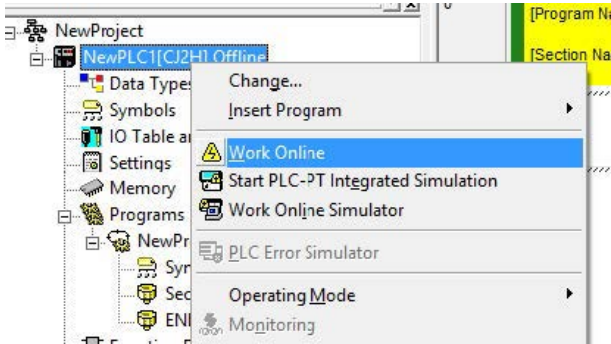

- 25. Click **Yes** to connect to the PLC.
- 26. Go to **View > Windows > Watch**.
- 27. Click on the top line in the **Watch** window.
The **Edit dialog** window opens.

Figure 245. Watch Window

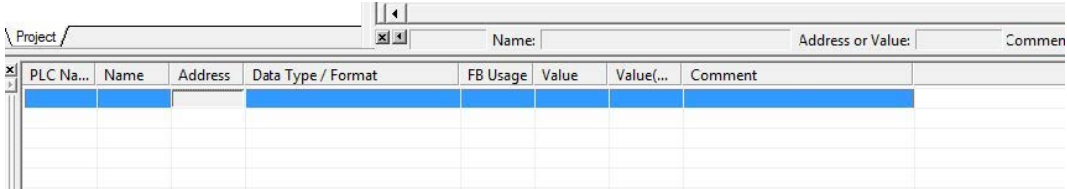

28. Add some registers to the **Watch** window.

Figure 246. Edit Dialog

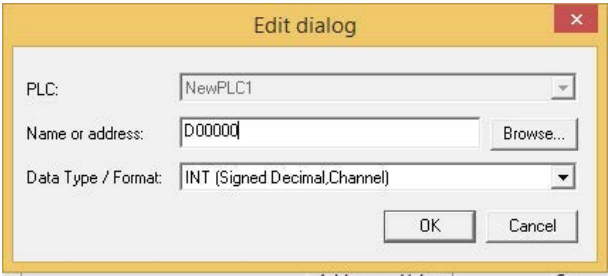

Figure 247. Watch Window—Four Registers

PLC Na...	Name	Address	Data Type / Format	FB Usage	Value	Value(Binary)	Commen
NewPLC1		D0	INT (Signed Decimal,Channel)		+2	0000 0000 0000 0010	
NewPLC1		D1	INT (Signed Decimal,Channel)		0	0000 0000 0000 0000	
NewPLC1		D2	INT (Signed Decimal,Channel)		0	0000 0000 0000 0000	
NewPLC1		D3	INT (Signed Decimal,Channel)		0	0000 0000 0000 0000	

In the **Watch** window in the preceding figure, there are four registers of Safety Controller Output (PLC Input) data. Notice how Virtual Output #2 is currently on (D0 register, bit 1).

12.5 Modbus[®] TCP

The Modbus[®] 43 TCP protocol provides device information using register and coil banks defined by the slave device.

This section defines the register and coil banks. By specification, Modbus TCP uses TCP port 502. The Safety Controller does not support a Unit ID of 0 (sometimes called Slave ID or Device ID).

The following registers are used to send output values from the Safety Controller to the PLC. These can be read as Input Registers (30000) using Modbus function code 04 (Read Input Registers). The same values can also be read as Holding Registers (40000) using Modbus function code 03 (Read Holding Registers). The status information for all the virtual outputs and their fault flags, contained in the first eight registers, can also be read as Inputs (10000) using Modbus function code 02 (Read Input Status).



Note: FID 2 and later XS/SC26 Safety Controllers differ from FID 1 XS/SC26 models in that FID 2 and later no longer allows access to the first 64 Virtual Outputs using Modbus TCP Coils 0001–00064, nor the first 64 Virtual Output Faults bits using Modbus TCP Coils 00065–00128.

12.5.1 Input and Coil Bits

The First 64 Virtual Outputs and Virtual Output Faults (Inputs 10001–10128)

Table 29: 02: Read Input Status

Input #	NAME	Input #	NAME
10001	VO1	10065	VO1 Fault bit
10002	VO2	10066	VO2 Fault bit
10003	VO3	10067	VO3 Fault bit
...
10063	VO63	10127	VO63 Fault bit
10064	VO64	10128	VO64 Fault bit

⁴³ Modbus[®] is a registered trademark of Schneider Electric USA, Inc.

All 256 Virtual Outputs and Virtual Output Faults (Inputs 11001-11256, 12001-12256)

Table 30: 02: Read Input Status

Input #	NAME	Input #	NAME
11001	VO1	12001	VO1 Fault bit
11002	VO2	12002	VO2 Fault bit
11003	VO3	12003	VO3 Fault bit
...
11255	VO255	12255	VO255 Fault bit
11256	VO256	12256	VO256 Fault bit

Virtual Input, Virtual Reset/Cancel Delay Control and Feedback (Coils 3001–3128, 4001–4032, Inputs 15001–15032)

See [Virtual Manual Reset and Cancel Delay \(RCD\) Sequence](#) on page 61.

Table 31: 05: Write Single Coil; 02: Read Input Status

Input #	NAME	Input #	NAME
3001	VI1 On/Off	15001	VRCD1 Feedback
3002	VI2 On/Off	15002	VRCD2 Feedback
...
3128	VI128 On/Off	15032	VRCD32 Feedback
4001	VRCD1 On/Off		
4002	VRCD2 On/Off		
...			
4032	VRCD32 On/Off		

12.5.2 Input and Holding Registers

Safety Controller Output Registers (Modbus TCP Input or Holding Registers)

Table 32: Safety Controller Output Registers (Modbus TCP Input or Holding Registers)

Input REG #	Holding REG #	WORD NAME	DATA TYPE
1	1	VO1 – VO16 (see Flags on page 242)	16-bit integer
2	2	VO17 – VO32 (see Flags on page 242)	16-bit integer
3	3	VO33 – VO48 (see Flags on page 242)	16-bit integer
4	4	VO49 – VO64 (see Flags on page 242)	16-bit integer
5	5	Fault bits for VO1 – VO16 (see Flags on page 242)	16-bit integer
6	6	Fault bits for VO17 – VO32 (see Flags on page 242)	16-bit integer
7	7	Fault bits for VO33 – VO48 (see Flags on page 242)	16-bit integer

Input REG #	Holding REG #	WORD NAME	DATA TYPE
8	8	Fault bits for VO49 – VO64 (see Flags on page 242)	16-bit integer
	9	Virtual Input On/Off (1-16)	16-bit integer
	10	Virtual Input On/Off (17-32)	16-bit integer
	11	Virtual Input On/Off (33-48)	16-bit integer
	12	Virtual Input On/Off (49-64)	16-bit integer
13–16	13–16	<i>reserved</i>	16-bit integer
	17	Virtual Reset/Cancel Delay (1–16) [RCD Register Bits] (see Virtual Manual Reset and Cancel Delay (RCD) Sequence on page 61)	16-bit integer
18	18	<i>reserved</i>	16-bit integer
	19	RCD Actuation Code [RCD Enable Register] (see Virtual Manual Reset and Cancel Delay (RCD) Sequence on page 61)	16-bit integer
20	20	Virtual Reset/Cancel Delay (1–16) Feedback [RCD Feedback Register Bits] (see Virtual Manual Reset and Cancel Delay (RCD) Sequence on page 61)	16-bit integer
21	21	<i>reserved</i>	16-bit integer
22	22	RCD Actuation Code Feedback [RCD Enable Feedback Register] (see Virtual Manual Reset and Cancel Delay (RCD) Sequence on page 61)	16-bit integer
23–40	23–40	<i>reserved</i>	16-bit integer
41	41	VO1 Fault Index	16-bit integer
42	42	VO2 Fault Index	16-bit integer
43	43	VO3 Fault Index	16-bit integer
44	44	VO4 Fault Index	16-bit integer
45	45	VO5 Fault Index	16-bit integer
46	46	VO6 Fault Index	16-bit integer
47	47	VO7 Fault Index	16-bit integer
48	48	VO8 Fault Index	16-bit integer
49	49	VO9 Fault Index	16-bit integer
50	50	VO10 Fault Index	16-bit integer
51	51	VO11 Fault Index	16-bit integer
52	52	VO12 Fault Index	16-bit integer
53	53	VO13 Fault Index	16-bit integer
54	54	VO14 Fault Index	16-bit integer
55	55	VO15 Fault Index	16-bit integer
56	56	VO16 Fault Index	16-bit integer
57	57	VO17 Fault Index	16-bit integer
58	58	VO18 Fault Index	16-bit integer
59	59	VO19 Fault Index	16-bit integer
60	60	VO20 Fault Index	16-bit integer
61	61	VO21 Fault Index	16-bit integer

Input REG #	Holding REG #	WORD NAME	DATA TYPE
62	62	VO22 Fault Index	16-bit integer
63	63	VO23 Fault Index	16-bit integer
64	64	VO24 Fault Index	16-bit integer
65	65	VO25 Fault Index	16-bit integer
66	66	VO26 Fault Index	16-bit integer
67	67	VO27 Fault Index	16-bit integer
68	68	VO28 Fault Index	16-bit integer
69	69	VO29 Fault Index	16-bit integer
70	70	VO30 Fault Index	16-bit integer
71	71	VO31 Fault Index	16-bit integer
72	72	VO32 Fault Index	16-bit integer
73	73	VO33 Fault Index	16-bit integer
74	74	VO34 Fault Index	16-bit integer
75	75	VO35 Fault Index	16-bit integer
76	76	VO36 Fault Index	16-bit integer
77	77	VO37 Fault Index	16-bit integer
78	78	VO38 Fault Index	16-bit integer
79	79	VO39 Fault Index	16-bit integer
80	80	VO40 Fault Index	16-bit integer
81	81	VO41 Fault Index	16-bit integer
82	82	VO42 Fault Index	16-bit integer
83	83	VO43 Fault Index	16-bit integer
84	84	VO44 Fault Index	16-bit integer
85	85	VO45 Fault Index	16-bit integer
86	86	VO46 Fault Index	16-bit integer
87	87	VO47 Fault Index	16-bit integer
88	88	VO48 Fault Index	16-bit integer
89	89	VO49 Fault Index	16-bit integer
90	90	VO50 Fault Index	16-bit integer
91	91	VO51 Fault Index	16-bit integer
92	92	VO52 Fault Index	16-bit integer
93	93	VO53 Fault Index	16-bit integer
94	94	VO54 Fault Index	16-bit integer
95	95	VO55 Fault Index	16-bit integer
96	96	VO56 Fault Index	16-bit integer
97	97	VO57 Fault Index	16-bit integer
98	98	VO58 Fault Index	16-bit integer
99	99	VO59 Fault Index	16-bit integer
100	100	VO60 Fault Index	16-bit integer

Input REG #	Holding REG #	WORD NAME	DATA TYPE
101	101	VO61 Fault Index	16-bit integer
102	102	VO62 Fault Index	16-bit integer
103	103	VO63 Fault Index	16-bit integer
104	104	VO64 Fault Index	16-bit integer
105–106	105–106	VO1 Complete Fault Code	32-bit integer
107–108	107–108	VO2 Complete Fault Code	32-bit integer
109–110	109–110	VO3 Complete Fault Code	32-bit integer
111–112	111–112	VO4 Complete Fault Code	32-bit integer
113–114	113–114	VO5 Complete Fault Code	32-bit integer
115–116	115–116	VO6 Complete Fault Code	32-bit integer
117–118	117–118	VO7 Complete Fault Code	32-bit integer
119–120	119–120	VO8 Complete Fault Code	32-bit integer
121–122	121–122	VO9 Complete Fault Code	32-bit integer
123–124	123–124	VO10 Complete Fault Code	32-bit integer
125–126	125–126	VO11 Complete Fault Code	32-bit integer
127–128	127–128	VO12 Complete Fault Code	32-bit integer
129–130	129–130	VO13 Complete Fault Code	32-bit integer
131–132	131–132	VO14 Complete Fault Code	32-bit integer
133–134	133–134	VO15 Complete Fault Code	32-bit integer
135–136	135–136	VO16 Complete Fault Code	32-bit integer
137–138	137–138	VO17 Complete Fault Code	32-bit integer
139–140	139–140	VO18 Complete Fault Code	32-bit integer
141–142	141–142	VO19 Complete Fault Code	32-bit integer
143–144	143–144	VO20 Complete Fault Code	32-bit integer
145–146	145–146	VO21 Complete Fault Code	32-bit integer
147–148	147–148	VO22 Complete Fault Code	32-bit integer
149–150	149–150	VO23 Complete Fault Code	32-bit integer
151–152	151–152	VO24 Complete Fault Code	32-bit integer
153–154	153–154	VO25 Complete Fault Code	32-bit integer
155–156	155–156	VO26 Complete Fault Code	32-bit integer
157–158	157–158	VO27 Complete Fault Code	32-bit integer
159–160	159–160	VO28 Complete Fault Code	32-bit integer
161–162	161–162	VO29 Complete Fault Code	32-bit integer
163–164	163–164	VO30 Complete Fault Code	32-bit integer
165–166	165–166	VO31 Complete Fault Code	32-bit integer
167–168	167–168	VO32 Complete Fault Code	32-bit integer
169–170	169–170	VO33 Complete Fault Code	32-bit integer
171–172	171–172	VO34 Complete Fault Code	32-bit integer
173–174	173–174	VO35 Complete Fault Code	32-bit integer

Input REG #	Holding REG #	WORD NAME	DATA TYPE
175–176	175–176	VO36 Complete Fault Code	32-bit integer
177–178	177–178	VO37 Complete Fault Code	32-bit integer
179–180	179–180	VO38 Complete Fault Code	32-bit integer
181–182	181–182	VO39 Complete Fault Code	32-bit integer
183–184	183–184	VO40 Complete Fault Code	32-bit integer
185–186	185–186	VO41 Complete Fault Code	32-bit integer
187–188	187–188	VO42 Complete Fault Code	32-bit integer
189–190	189–190	VO43 Complete Fault Code	32-bit integer
191–192	191–192	VO44 Complete Fault Code	32-bit integer
193–194	193–194	VO45 Complete Fault Code	32-bit integer
195–196	195–196	VO46 Complete Fault Code	32-bit integer
197–198	197–198	VO47 Complete Fault Code	32-bit integer
199–200	199–200	VO48 Complete Fault Code	32-bit integer
201–202	201–202	VO49 Complete Fault Code	32-bit integer
203–204	203–204	VO50 Complete Fault Code	32-bit integer
205–206	205–206	VO51 Complete Fault Code	32-bit integer
207–208	207–208	VO52 Complete Fault Code	32-bit integer
209–210	209–210	VO53 Complete Fault Code	32-bit integer
211–212	211–212	VO54 Complete Fault Code	32-bit integer
213–214	213–214	VO55 Complete Fault Code	32-bit integer
215–216	215–216	VO56 Complete Fault Code	32-bit integer
217–218	217–218	VO57 Complete Fault Code	32-bit integer
219–220	219–220	VO58 Complete Fault Code	32-bit integer
221–222	221–222	VO59 Complete Fault Code	32-bit integer
223–224	223–224	VO60 Complete Fault Code	32-bit integer
225–226	225–226	VO61 Complete Fault Code	32-bit integer
227–228	227–228	VO62 Complete Fault Code	32-bit integer
229–230	229–230	VO63 Complete Fault Code	32-bit integer
231–232	231–232	VO64 Complete Fault Code	32-bit integer
233–234	233–234	Fault #1 Time Stamp	32-bit integer
235–242	235–242	Fault #1 Name of I/O or System	2-word length + 12-ASCII characters
243	243	Fault #1 Error Code	16-bit integer
244	244	Fault #1 Advanced Error Code	16-bit integer
245	245	Fault #1 Error Message Index	16-bit integer
246–247	246–247	<i>reserved</i>	16-bit integer
248–249	248–249	Fault #2 Time Stamp	32-bit integer
250–257	250–257	Fault #2 Name of I/O or System	2-word length + 12-ASCII characters
258	258	Fault #2 Error Code	16-bit integer
259	259	Fault #2 Advanced Error Code	16-bit integer

Input REG #	Holding REG #	WORD NAME	DATA TYPE
260	260	Fault #2 Error Message Index	16-bit integer
261–262	261–262	<i>reserved</i>	16-bit integer
263–264	263–264	Fault #3 Time Stamp	32-bit integer
265–272	265–272	Fault #3 Name of I/O or System	2-word length + 12-ASCII characters
273	273	Fault #3 Error Code	16-bit integer
274	274	Fault #3 Advanced Error Code	16-bit integer
275	275	Fault #3 Error Message Index	16-bit integer
276–277	276–277	<i>reserved</i>	16-bit integer
278–279	278–279	Fault #4 Time Stamp	32-bit integer
280–287	280–287	Fault #4 Name of I/O or System	2-word length + 12-ASCII characters
288	288	Fault #4 Error Code	16-bit integer
289	289	Fault #4 Advanced Error Code	16-bit integer
290	290	Fault #4 Error Message Index	16-bit integer
291–292	291–292	<i>reserved</i>	16-bit integer
293–294	293–294	Fault #5 Time Stamp	32-bit integer
295–302	295–302	Fault #5 Name of I/O or System	2-word length + 12-ASCII characters
303	303	Fault #5 Error Code	16-bit integer
304	304	Fault #5 Advanced Error Code	16-bit integer
305	305	Fault #5 Error Message Index	16-bit integer
306–307	306–307	<i>reserved</i>	16-bit integer
308–309	308–309	Fault #6 Time Stamp	32-bit integer
310–317	310–317	Fault #6 Name of I/O or System	2-word length + 12-ASCII characters
318	318	Fault #6 Error Code	16-bit integer
319	319	Fault #6 Advanced Error Code	16-bit integer
320	320	Fault #6 Error Message Index	16-bit integer
321–322	321–322	<i>reserved</i>	16-bit integer
323–324	323–324	Fault #7 Time Stamp	32-bit integer
325–332	325–332	Fault #7 Name of I/O or System	2-word length + 12-ASCII characters
333	333	Fault #7 Error Code	16-bit integer
334	334	Fault #7 Advanced Error Code	16-bit integer
335	335	Fault #7 Error Message Index	16-bit integer
336–337	336–337	<i>reserved</i>	16-bit integer
338–339	338–339	Fault #8 Time Stamp	32-bit integer
340–347	340–347	Fault #8 Name of I/O or System	2-word length + 12-ASCII characters
348	348	Fault #8 Error Code	16-bit integer
349	349	Fault #8 Advanced Error Code	16-bit integer
350	350	Fault #8 Error Message Index	16-bit integer
351–352	351–352	<i>reserved</i>	16-bit integer
353–354	353–354	Fault #9 Time Stamp	32-bit integer

Input REG #	Holding REG #	WORD NAME	DATA TYPE
355–362	355–362	Fault #9 Name of I/O or System	2-word length + 12-ASCII characters
363	363	Fault #9 Error Code	16-bit integer
364	364	Fault #9 Advanced Error Code	16-bit integer
365	365	Fault #9 Error Message Index	16-bit integer
366–367	366–367	<i>reserved</i>	16-bit integer
368–369	368–369	Fault #10 Time Stamp	32-bit integer
370–377	370–377	Fault #10 Name of I/O or System	2-word length + 12-ASCII characters
378	378	Fault #10 Error Code	16-bit integer
379	379	Fault #10 Advanced Error Code	16-bit integer
380	380	Fault #10 Error Message Index	16-bit integer
381–382	381–382	<i>reserved</i>	16-bit integer
383–384	383–384	Seconds Since Boot	32-bit integer
385	385	Operating Mode	16-bit integer
386–395	386–395	ConfigName	2-word length + 16-ASCII characters
396–397	396–397	Config CRC	32-bit integer
398–900	398–900	<i>reserved</i>	16-bit integer
901	901	VO1 – VO16 (see Flags on page 242)	16-bit integer
902	902	VO17 – VO32 (see Flags on page 242)	16-bit integer
903	903	VO33 – VO48 (see Flags on page 242)	16-bit integer
904	904	VO49 – VO64 (see Flags on page 242)	16-bit integer
905	905	VO65 – VO80 (see Extended Flags on page 243)	16-bit integer
906	906	VO81 – VO96 (see Extended Flags on page 243)	16-bit integer
907	907	VO97 – VO112 (see Extended Flags on page 243)	16-bit integer
908	908	VO113 – VO128 (see Extended Flags on page 243)	16-bit integer
909	909	VO129 – VO144 (see Extended Flags on page 243)	16-bit integer
910	910	VO145 – VO160 (see Extended Flags on page 243)	16-bit integer
911	911	VO161 – VO176 (see Extended Flags on page 243)	16-bit integer
912	912	VO177 – VO192 (see Extended Flags on page 243)	16-bit integer
913	913	VO193 – VO208 (see Extended Flags on page 243)	16-bit integer
914	914	VO209 – VO224 (see Extended Flags on page 243)	16-bit integer
915	915	VO225 – VO240 (see Extended Flags on page 243)	16-bit integer
916	916	VO241 – VO256 (see Extended Flags on page 243)	16-bit integer
917	917	Fault bits for VO1 – VO16 (see Flags on page 242)	16-bit integer

Input REG #	Holding REG #	WORD NAME	DATA TYPE
918	918	Fault bits for VO17 – VO32 (see Flags on page 242)	16-bit integer
919	919	Fault bits for VO33 – VO48 (see Flags on page 242)	16-bit integer
920	920	Fault bits for VO49 – VO64 (see Flags on page 242)	16-bit integer
921	921	Fault bits for VO65 – VO80 (see Extended Flags on page 243)	16-bit integer
922	922	Fault bits for VO81 – VO96 (see Extended Flags on page 243)	16-bit integer
923	923	Fault bits for VO97 – VO112 (see Extended Flags on page 243)	16-bit integer
924	924	Fault bits for VO113 – VO128 (see Extended Flags on page 243)	16-bit integer
925	925	Fault bits for VO129 – VO144 (see Extended Flags on page 243)	16-bit integer
926	926	Fault bits for VO145 – VO160 (see Extended Flags on page 243)	16-bit integer
926	926	Fault bits for VO161 – VO176 (see Extended Flags on page 243)	16-bit integer
928	928	Fault bits for VO177 – VO192 (see Extended Flags on page 243)	16-bit integer
929	929	Fault bits for VO193 – VO208 (see Extended Flags on page 243)	16-bit integer
930	930	Fault bits for VO209 – VO224 (see Extended Flags on page 243)	16-bit integer
931	931	Fault bits for VO225 – VO240 (see Extended Flags on page 243)	16-bit integer
932	932	Fault bits for VO241 – VO256 (see Extended Flags on page 243)	16-bit integer
933–934	933–934	RCD bits feedback (see Virtual Manual Reset and Cancel Delay (RCD) Sequence on page 61)	32-bit integer
935	935	RCD Enable feedback (see Virtual Manual Reset and Cancel Delay (RCD) Sequence on page 61)	16-bit integer
936	936	VO1 Fault Index	16-bit integer
937	937	VO2 Fault Index	16-bit integer
938	938	VO3 Fault Index	16-bit integer
...
1190	1190	VO256 Fault Index	16-bit integer
1191–1192	1191–1192	VO1 Complete Fault Code	32-bit integer
1193–1194	1193–1194	VO2 Complete Fault Code	32-bit integer
1195–1196	1195–1196	VO3 Complete Fault Code	32-bit integer
1197–1198	1197–1198	VO4 Complete Fault Code	32-bit integer
...
1702–1703	1702–1703	VO256 Complete Fault Code	32-bit integer
1704–1705	1704–1705	ISD System Status - Chain 1 Device Count	32-bit integer

Input REG #	Holding REG #	WORD NAME	DATA TYPE
1706–1707	1706–1707	ISD System Status - Chain 2 Device Count	32-bit integer
1708–1709	1708–1709	ISD System Status - Chain 1 Device On/Off Status (see ISD System Status Words on page 206)	32-bit integer
1710–1711	1710–1711	ISD System Status - Chain 2 Device On/Off Status (see ISD System Status Words on page 206)	32-bit integer
1712–1713	1712–1713	ISD System Status - Chain 1 Fault Status (see ISD System Status Words on page 206)	32-bit integer
1714–1715	1714–1715	ISD System Status - Chain 2 Fault Status (see ISD System Status Words on page 206)	32-bit integer
1716–1717	1716–1717	ISD System Status - Chain 1 Marginal Status (see ISD System Status Words on page 206)	32-bit integer
1718–1719	1718–1719	ISD System Status - Chain 2 Marginal Status (see ISD System Status Words on page 206)	32-bit integer
1720–1721	1720–1721	ISD System Status - Chain 1 Alert Status (see ISD System Status Words on page 206)	32-bit integer
1722–1723	1722–1723	ISD System Status - Chain 2 Alert Status (see ISD System Status Words on page 206)	32-bit integer
1724–1725	1724–1725	ISD System Status - Chain 1 Reset Status (see ISD System Status Words on page 206)	32-bit integer
1726–1727	1726–1727	ISD System Status - Chain 2 Reset Status (see ISD System Status Words on page 206)	32-bit integer
1728–1729	1728–1729	ISD System Status - Chain 1 Actuator Recognized (see ISD System Status Words on page 206)	32-bit integer
1730–1731	1730–1731	ISD System Status - Chain 2 Actuator Recognized (see ISD System Status Words on page 206)	32-bit integer
1732–1733	1732–1733	ISD System Status - Chain 1 System Status (see ISD Chain System Status on page 50)	32-bit integer
1734–1735	1734–1735	ISD System Status - Chain 2 System Status (see ISD Chain System Status on page 50)	32-bit integer
1736–1751	1736–1751	List of Detected ISD Devices on a Chain	32 byte array
1752–1768	1752–1768	<i>reserved</i>	16-bit integer
1769	1769	ISD Read Request Acknowledge (see Request Performance and Status Information about an Individual Device via ISD on page 50)	16-bit integer
1770	1770	ISD Chain Requested Acknowledge (see Request Performance and Status Information about an Individual Device via ISD on page 50)	16-bit integer
1771	1771	ISD Device Requested Acknowledge (see Request Performance and Status Information about an Individual Device via ISD on page 50)	16-bit integer
1772–1780	1772–1780	ISD Individual Device-Specific Data ⁴⁶ (see ISD Individual Device-Specific Data Detailed Description on page 243)	16-bit integer
	1781	ISD Read Request (see Request Performance and Status Information about an Individual Device via ISD on page 50)	16-bit integer

⁴⁶ For conversion to Internal Temperature, Actuator Distance, and Supply Voltage, see [ISD: Temperature, Voltage, and Distance Conversion Information](#) on page 296.

Input REG #	Holding REG #	WORD NAME	DATA TYPE
	1782	ISD Chain Requested (see Request Performance and Status Information about an Individual Device via ISD on page 50)	16-bit integer
	1783	ISD Device Requested (see Request Performance and Status Information about an Individual Device via ISD on page 50)	16-bit integer
1784–1785	1784–1785	ISD System Status – Chain 1 Device Count	32-bit integer
1786–1787	1786–1787	ISD System Status – Chain 1 Device On/Off Status (see ISD System Status Words on page 206)	32-bit integer
1788–1789	1788–1789	ISD System Status – Chain 1 Fault Status (see ISD System Status Words on page 206)	32-bit integer
1790–1791	1790–1791	ISD System Status – Chain 1 Marginal Status (see ISD System Status Words on page 206)	32-bit integer
1792–1793	1792–1793	ISD System Status – Chain 1 Alert Status (see ISD System Status Words on page 206)	32-bit integer
1794–1795	1794–1795	ISD System Status – Chain 1 Reset Status (see ISD System Status Words on page 206)	32-bit integer
1796–1797	1796–1797	ISD System Status – Chain 1 Actuator Recognized Status (see ISD System Status Words on page 206)	32-bit integer
1798–1799	1798–1799	ISD System Status – Chain 1 System Status (see ISD Chain System Status on page 50)	32-bit integer
1800–1801	1800–1801	ISD System Status – Chain 2 Device Count	32-bit integer
1802–1803	1802–1803	ISD System Status – Chain 2 Device On/Off Status (see ISD System Status Words on page 206)	32-bit integer
1804–1805	1804–1805	ISD System Status – Chain 2 Fault Status (see ISD System Status Words on page 206)	32-bit integer
1806–1807	1806–1807	ISD System Status – Chain 2 Marginal Status (see ISD System Status Words on page 206)	32-bit integer
1808–1809	1808–1809	ISD System Status – Chain 2 Alert Status (see ISD System Status Words on page 206)	32-bit integer
1810–1811	1810–1811	ISD System Status – Chain 2 Reset Status (see ISD System Status Words on page 206)	32-bit integer
1812–1813	1812–1813	ISD System Status – Chain 2 Actuator Recognized Status (see ISD System Status Words on page 206)	32-bit integer
1814–1815	1814–1815	ISD System Status – Chain 2 System Status (see ISD Chain System Status on page 50)	32-bit integer
1816–1817	1816–1817	ISD System Status – Chain 3 Device Count	32-bit integer
1818–1819	1818–1819	ISD System Status – Chain 3 Device On/Off Status (see ISD System Status Words on page 206)	32-bit integer
1820–1821	1820–1821	ISD System Status – Chain 3 Fault Status (see ISD System Status Words on page 206)	32-bit integer
1822–1823	1822–1823	ISD System Status – Chain 3 Marginal Status (see ISD System Status Words on page 206)	32-bit integer
1824–1825	1824–1825	ISD System Status – Chain 3 Alert Status (see ISD System Status Words on page 206)	32-bit integer
1826–1827	1826–1827	ISD System Status – Chain 3 Reset Status (see ISD System Status Words on page 206)	32-bit integer
1828–1829	1828–1829	ISD System Status – Chain 3 Actuator Recognized Status (see ISD System Status Words on page 206)	32-bit integer

Input REG #	Holding REG #	WORD NAME	DATA TYPE
1830–1831	1830–1831	ISD System Status – Chain 3 System Status (see ISD Chain System Status on page 50)	32-bit integer
1832–1833	1832–1833	ISD System Status – Chain 4 Device Count	32-bit integer
1834–1835	1834–1835	ISD System Status – Chain 4 Device On/Off Status (see ISD System Status Words on page 206)	32-bit integer
1836–1837	1836–1837	ISD System Status – Chain 4 Fault Status (see ISD System Status Words on page 206)	32-bit integer
1838–1839	1838–1839	ISD System Status – Chain 4 Marginal Status (see ISD System Status Words on page 206)	32-bit integer
1840–1841	1840–1841	ISD System Status – Chain 4 Alert Status (see ISD System Status Words on page 206)	32-bit integer
1842–1843	1842–1843	ISD System Status – Chain 4 Reset Status (see ISD System Status Words on page 206)	32-bit integer
1844–1845	1844–1845	ISD System Status – Chain 4 Actuator Recognized Status (see ISD System Status Words on page 206)	32-bit integer
1846–1847	1846–1847	ISD System Status – Chain 4 System Status (see ISD Chain System Status on page 50)	32-bit integer
1848–1849	1848–1849	ISD System Status – Chain 5 Device Count	32-bit integer
1850–1851	1850–1851	ISD System Status – Chain 5 Device On/Off Status (see ISD System Status Words on page 206)	32-bit integer
1852–1853	1852–1853	ISD System Status – Chain 5 Fault Status (see ISD System Status Words on page 206)	32-bit integer
1854–1855	1854–1855	ISD System Status – Chain 5 Marginal Status (see ISD System Status Words on page 206)	32-bit integer
1856–1857	1856–1857	ISD System Status – Chain 5 Alert Status (see ISD System Status Words on page 206)	32-bit integer
1858–1859	1858–1859	ISD System Status – Chain 5 Reset Status (see ISD System Status Words on page 206)	32-bit integer
1860–1861	1860–1861	ISD System Status – Chain 5 Actuator Recognized Status (see ISD System Status Words on page 206)	32-bit integer
1862–1863	1862–1863	ISD System Status – Chain 5 System Status (see ISD Chain System Status on page 50)	32-bit integer
1864–1865	1864–1865	ISD System Status – Chain 6 Device Count	32-bit integer
1866–1867	1866–1867	ISD System Status – Chain 6 Device On/Off Status (see ISD System Status Words on page 206)	32-bit integer
1868–1869	1868–1869	ISD System Status – Chain 6 Fault Status (see ISD System Status Words on page 206)	32-bit integer
1870–1871	1870–1871	ISD System Status – Chain 6 Marginal Status (see ISD System Status Words on page 206)	32-bit integer
1872–1873	1872–1873	ISD System Status – Chain 6 Alert Status (see ISD System Status Words on page 206)	32-bit integer
1874–1875	1874–1875	ISD System Status – Chain 6 Reset Status (see ISD System Status Words on page 206)	32-bit integer
1876–1877	1876–1877	ISD System Status – Chain 6 Actuator Recognized Status (see ISD System Status Words on page 206)	32-bit integer
1878–1879	1878–1879	ISD System Status – Chain 6 System Status (see ISD Chain System Status on page 50)	32-bit integer
1880–1881	1880–1881	ISD System Status – Chain 7 Device Count	32-bit integer

Input REG #	Holding REG #	WORD NAME	DATA TYPE
1882–1883	1882–1883	ISD System Status – Chain 7 Device On/Off Status (see ISD System Status Words on page 206)	32-bit integer
1884–1885	1884–1885	ISD System Status – Chain 7 Fault Status (see ISD System Status Words on page 206)	32-bit integer
1886–1887	1886–1887	ISD System Status – Chain 7 Marginal Status (see ISD System Status Words on page 206)	32-bit integer
1888–1889	1888–1889	ISD System Status – Chain 7 Alert Status (see ISD System Status Words on page 206)	32-bit integer
1890–1891	1890–1891	ISD System Status – Chain 7 Reset Status (see ISD System Status Words on page 206)	32-bit integer
1892–1893	1892–1893	ISD System Status – Chain 7 Actuator Recognized Status (see ISD System Status Words on page 206)	32-bit integer
1894–1895	1894–1895	ISD System Status – Chain 7 System Status (see ISD Chain System Status on page 50)	32-bit integer
1896–1897	1896–1897	ISD System Status – Chain 8 Device Count	32-bit integer
1898–1899	1898–1899	ISD System Status – Chain 8 Device On/Off Status (see ISD System Status Words on page 206)	32-bit integer
1900–1901	1900–1901	ISD System Status – Chain 8 Fault Status (see ISD System Status Words on page 206)	32-bit integer
1902–1903	1902–1903	ISD System Status – Chain 8 Marginal Status (see ISD System Status Words on page 206)	32-bit integer
1904–1905	1904–1905	ISD System Status – Chain 8 Alert Status (see ISD System Status Words on page 206)	32-bit integer
1906–1907	1906–1907	ISD System Status – Chain 8 Reset Status (see ISD System Status Words on page 206)	32-bit integer
1908–1909	1908–1909	ISD System Status – Chain 8 Actuator Recognized Status (see ISD System Status Words on page 206)	32-bit integer
1910–1911	1910–1911	ISD System Status – Chain 8 System Status (see ISD Chain System Status on page 50)	32-bit integer



Note: The ISD data is not immediately available upon power up. The ISD data can be delayed up to 10 seconds after the system power has been turned on.

Flags

Registers 1 through 8, defined below, appear as the first eight words in register map.

This represents the first 64 virtual outputs and the associated fault flags. The information in these registers can be read as Input Registers (30000) using Modbus function code 04 (Read Input Registers). The same values can also be read as Holding Registers (40000) using Modbus function code 03 (Read Holding Registers).

Table 33: Virtual Output 1–16

PLC Input register 30001 or Holding Register 40001, also Inputs 10001–16 or Coils 00001–16

bit 15	bit 14	bit 13	bit 12	bit 11	bit 10	bit 9	bit 8	bit 7	bit 6	bit 5	bit 4	bit 3	bit 2	bit 1	bit 0
VO16	VO15	VO14	VO13	VO12	VO11	VO10	VO9	VO8	VO7	VO6	VO5	VO4	VO3	VO2	VO1

Table 34: Virtual Output 17–32

PLC Input register 30002 or Holding Register 40002, also Inputs 10017–32 or Coils 00017–32

bit 15	bit 14	bit 13	bit 12	bit 11	bit 10	bit 9	bit 8	bit 7	bit 6	bit 5	bit 4	bit 3	bit 2	bit 1	bit 0
VO32	VO31	VO30	VO29	VO28	VO27	VO26	VO25	VO24	VO23	VO22	VO21	VO20	VO19	VO18	VO17

Table 35: Virtual Output 33–48

PLC Input register 30003 or Holding Register 40003, also Inputs 10033–48 or Coils 00033–48

bit 15	bit 14	bit 13	bit 12	bit 11	bit 10	bit 9	bit 8	bit 7	bit 6	bit 5	bit 4	bit 3	bit 2	bit 1	bit 0
VO48	VO47	VO46	VO45	VO44	VO43	VO42	VO41	VO40	VO39	VO38	VO37	VO36	VO35	VO34	VO33

Table 36: Virtual Output 49–64

PLC Input register 30004 or Holding Register 40004, also Inputs 10049–64 or Coils 00049–64

bit 15	bit 14	bit 13	bit 12	bit 11	bit 10	bit 9	bit 8	bit 7	bit 6	bit 5	bit 4	bit 3	bit 2	bit 1	bit 0
VO64	VO63	VO62	VO61	VO60	VO59	VO58	VO57	VO56	VO55	VO54	VO53	VO52	VO51	VO50	VO49

Table 37: Virtual Output Fault 1–16

PLC Input register 30005 or Holding Register 40005, also Inputs 10033–48 or Coils 00033–48

bit 15	bit 14	bit 13	bit 12	bit 11	bit 10	bit 9	bit 8	bit 7	bit 6	bit 5	bit 4	bit 3	bit 2	bit 1	bit 0
VO16 fault	VO15 fault	VO14 fault	VO13 fault	VO12 fault	VO11 fault	VO10 fault	VO9 fault	VO8 fault	VO7 fault	VO6 fault	VO5 fault	VO4 fault	VO3 fault	VO2 fault	VO1 fault

Table 38: Virtual Output Fault 17–32

PLC Input register 30006 or Holding Register 40006, also Inputs 10049–64 or Coils 00049–64

bit 15	bit 14	bit 13	bit 12	bit 11	bit 10	bit 9	bit 8	bit 7	bit 6	bit 5	bit 4	bit 3	bit 2	bit 1	bit 0
VO32 fault	VO31 fault	VO30 fault	VO29 fault	VO28 fault	VO27 fault	VO26 fault	VO25 fault	VO24 fault	VO23 fault	VO22 fault	VO21 fault	VO20 fault	VO19 fault	VO18 fault	VO17 fault

Table 39: Virtual Output Fault 33–48

PLC Input register 30007 or Holding Register 40007, also Inputs 10033–48 or Coils 00033–48

bit 15	bit 14	bit 13	bit 12	bit 11	bit 10	bit 9	bit 8	bit 7	bit 6	bit 5	bit 4	bit 3	bit 2	bit 1	bit 0
VO48 fault	VO47 fault	VO46 fault	VO45 fault	VO44 fault	VO43 fault	VO42 fault	VO41 fault	VO40 fault	VO39 fault	VO38 fault	VO37 fault	VO36 fault	VO35 fault	VO34 fault	VO33 fault

Table 40: Virtual Output Fault 49–64

PLC Input register 30008 or Holding Register 40008, also Inputs 10049–64 or Coils 00049–64

bit 15	bit 14	bit 13	bit 12	bit 11	bit 10	bit 9	bit 8	bit 7	bit 6	bit 5	bit 4	bit 3	bit 2	bit 1	bit 0
VO64 fault	VO63 fault	VO62 fault	VO61 fault	VO60 fault	VO59 fault	VO58 fault	VO57 fault	VO56 fault	VO55 fault	VO54 fault	VO53 fault	VO52 fault	VO51 fault	VO50 fault	VO49 fault

Extended Flags

All 256 Virtual Outputs can be accessed in a way similar to that seen in [Flags](#) on page 242.

Inputs 11001 through 11256 represent all 256 possible Virtual Outputs. These Virtual Outputs can also be read as Input Registers 901-916 or Holding Registers 901-916.

Inputs 12001 through 12256 are all 256 Virtual Output Faults. These Virtual Output Faults can also be read as Input Registers 917-932 or Holding Registers 917-932.

ISD Individual Device-Specific Data Detailed Description

The following table describes Data Input and Holding Registers 1772–1780.

Table 41: ISD Individual Device-Specific Data Detailed Description

Input REG #	Holding REG #	Information	Data size
1772.0	1772.0	Safety Input Fault	1 bit
1772.1	1772.1	<i>reserved</i>	1 bit
1772.2	1772.2	Sensor Not Paired	1-bit
1772.3	1772.3	ISD Data Error	1-bit
1772.4	1772.4	Wrong Actuator/Button Status/Input Status	1-bit
1772.5	1772.5	Marginal Range/Button Status/Input Status	1-bit
1772.6	1772.6	Actuator Detected	1-bit

Input REG #	Holding REG #	Information	Data size
1772.7	1772.7	Output Error	1-bit
1772.8	1772.8	Input 2	1-bit
1772.9	1772.9	Input 1	1-bit
1772.10	1772.10	Local Reset Expected	1-bit
1772.11	1772.11	Operating Voltage Warning	1-bit
1772.12	1772.12	Operating Voltage Error	1-bit
1772.13	1772.13	Output 2	1-bit
1772.14	1772.14	Output 1	1-bit
1772.15	1772.15	Power Cycle Required	1-bit
1773.0	1773.0	Fault Tolerant Outputs	1-bit
1773.1	1773.1	Local Reset Unit	1-bit
1773.2	1773.2	Cascadable	1-bit
1773.3	1773.3	High Coding Level	1-bit
1773.4 to 1773.7	1773.4 to 1773.7	Teach-ins Remaining	4-bit
1773.8 to 1773.12	1773.8 to 1773.12	Device ID	5-bit
1773.13 to 1774.2	1773.13 to 1774.2	Range Warning Count	6-bit
1774.3 to 1774.7	1774.3 to 1774.7	Output Switch-off Time	5-bit
1774.8 to 1774.15	1774.8 to 1774.15	Number of Voltage Errors	8-bit
1775.0 to 1775.7	1775.0 to 1775.7	Internal Temperature ⁴⁷	8-bit
1775.8 to 1775.15	1775.8 to 1775.15	Actuator Distance ⁴⁷	8-bit
1776.0 to 1776.7	1776.0 to 1776.7	Supply Voltage ⁴⁷	8-bit
1776.8 to 1776.11	1776.8 to 1776.11	Expected Company Name	4-bit
1776.12 to 1776.15	1776.12 to 1776.15	Received Company Name	4-bit
1777	1777	Expected Code	16-bit
1778	1778	Received Code	16-bit
1779	1779	Internal Error A	16-bit
1780	1780	Internal Error B	16-bit

12.6 PLC5, SLC500, and MicroLogix (PCCC)

Allen-Bradley's PLC5, SLC 500, and MicroLogix family of devices uses PCCC communications protocol.

PCCC is also known as EtherNet/IP transport class 3 and uses explicit Read and Write message commands, or EIP messaging, placed into the ladder logic program, to interface with the Safety Controller.

These PLCs do not support cyclic EtherNet/IP IO data transfer (referred to as EtherNet/IP in this manual). The programming software used by these PLCs is RSLogix 5 (PLC5) or RSLogix 500 (SLC500 and MicroLogix series).

The Safety Controller supports these PLCs using an input register array. The term *Input* is from the point of view of the PLC.

⁴⁷ For conversion to Internal Temperature, Actuator Distance, and Supply Voltage, see [ISD: Temperature, Voltage, and Distance Conversion Information](#) on page 296.

12.6.1 PLC Configuration

The images below represent a typical configuration.

- 1. Read. Message command reading from N7 table on the Safety Controller.

Figure 248. Message Command reading 100 registers from the Safety Controller's N7 table

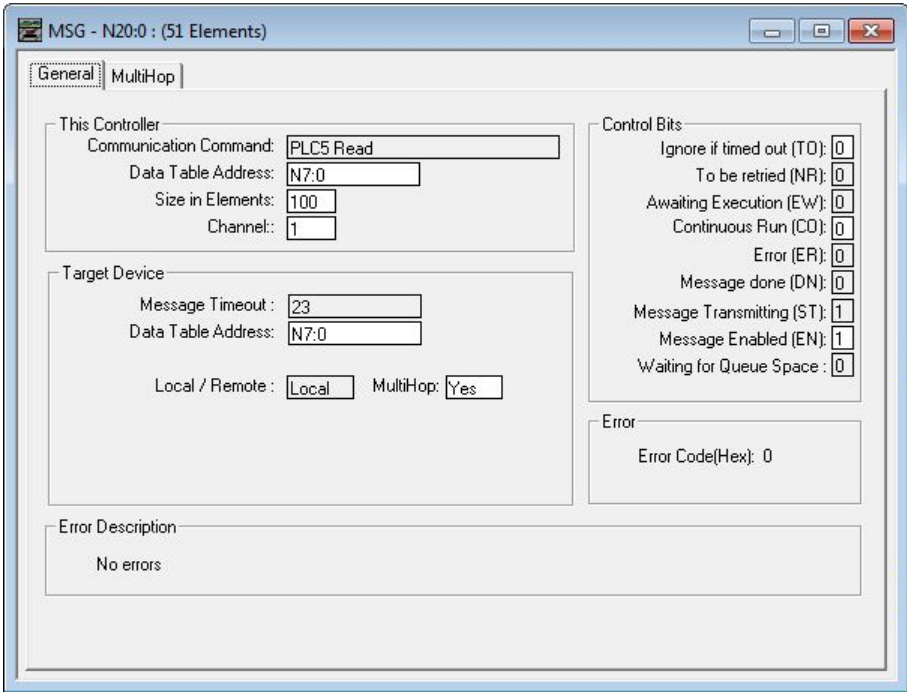

- 2. Read. IP Address of the Safety Controller is entered here.

Figure 249. Add the Safety Controller's IP Address in the To Address area

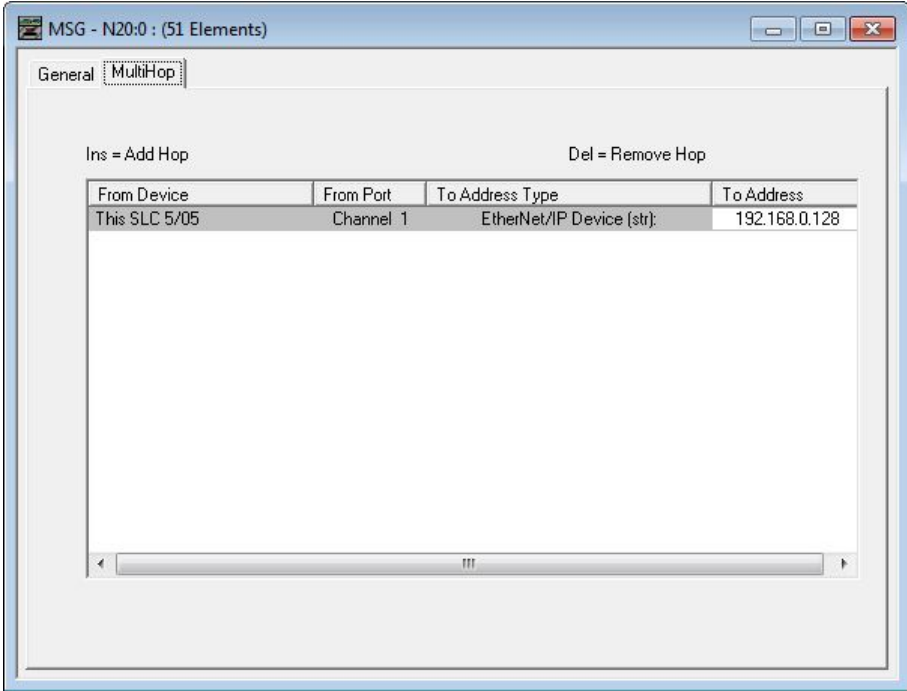

- 3. Write. Message command writing to N11 table on Safety Controller.

Figure 250. Message Command writing 20 registers to the Safety Controller's N11 table

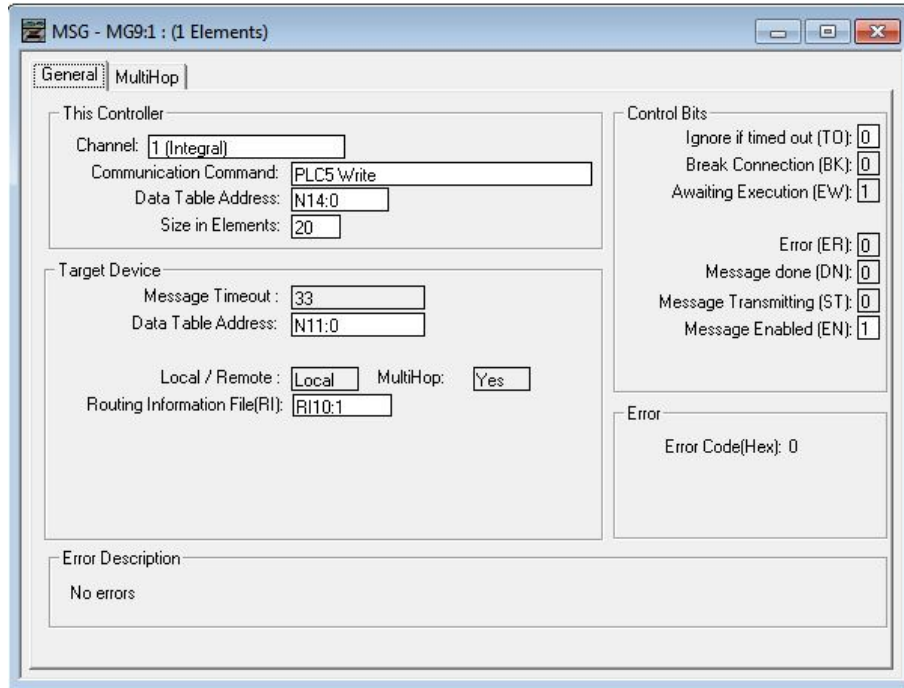

4. Write. IP Address of the Safety Controller is entered here.

Figure 251. Add the Safety Controller's IP Address in the To Address area

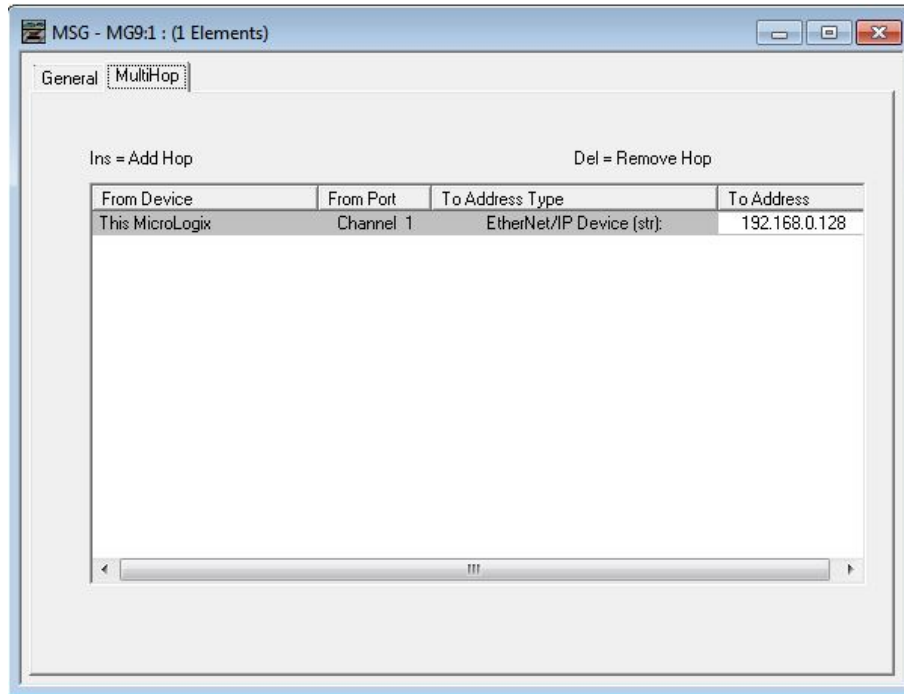

12.6.2 Outputs from Safety Controller (Inputs to PLC)

The Output registers are used to push output values from the Safety Controller to the PLC. There are two tables of output values due to size. MSG (message) commands are used to Read (N7, N20) from the Safety Controller.

 **Note:** Not all Safety Controllers support ISD.

 **Note:** Only the XS26-ISD supports eight chains of ISD devices.

Table 42: N7 REGS

REG #	WORD NAME	DATA TYPE
0	VO1 – VO16 (see Flags on page 258)	16-bit integer
1	VO17 – VO32 (see Flags on page 258)	16-bit integer
2	VO33 – VO48 (see Flags on page 258)	16-bit integer
3	VO49 – VO64 (see Flags on page 258)	16-bit integer
4	Fault bits for VO1 – VO16 (see Flags on page 258)	16-bit integer
5	Fault bits for VO17 – VO32 (see Flags on page 258)	16-bit integer
6	Fault bits for VO33 – VO48 (see Flags on page 258)	16-bit integer
7	Fault bits for VO49 – VO64 (see Flags on page 258)	16-bit integer
8–18	<i>reserved</i>	16-bit integer
19	Virtual Reset/Cancel Delay (1–16) Feedback [RCD Feedback Register Bits] (see Virtual Manual Reset and Cancel Delay (RCD) Sequence on page 61)	16-bit integer
20	<i>reserved</i>	16-bit integer
21	RCD Actuation Code Feedback [RCD Enable Feedback Register] (see Virtual Manual Reset and Cancel Delay (RCD) Sequence on page 61)	16-bit integer
22–39	<i>reserved</i>	16-bit integer
40	VO1 Fault Index	16-bit integer
41	VO2 Fault Index	16-bit integer
42	VO3 Fault Index	16-bit integer
43	VO4 Fault Index	16-bit integer
44	VO5 Fault Index	16-bit integer
45	VO6 Fault Index	16-bit integer
46	VO7 Fault Index	16-bit integer
47	VO8 Fault Index	16-bit integer
48	VO9 Fault Index	16-bit integer
49	VO10 Fault Index	16-bit integer
50	VO11 Fault Index	16-bit integer
51	VO12 Fault Index	16-bit integer
52	VO13 Fault Index	16-bit integer
53	VO14 Fault Index	16-bit integer
54	VO15 Fault Index	16-bit integer
55	VO16 Fault Index	16-bit integer
56	VO17 Fault Index	16-bit integer
57	VO18 Fault Index	16-bit integer
58	VO19 Fault Index	16-bit integer
59	VO20 Fault Index	16-bit integer
60	VO21 Fault Index	16-bit integer
61	VO22 Fault Index	16-bit integer
62	VO23 Fault Index	16-bit integer

REG #	WORD NAME	DATA TYPE
63	VO24 Fault Index	16-bit integer
64	VO25 Fault Index	16-bit integer
65	VO26 Fault Index	16-bit integer
66	VO27 Fault Index	16-bit integer
67	VO28 Fault Index	16-bit integer
68	VO29 Fault Index	16-bit integer
69	VO30 Fault Index	16-bit integer
70	VO31 Fault Index	16-bit integer
71	VO32 Fault Index	16-bit integer
72	VO33 Fault Index	16-bit integer
73	VO34 Fault Index	16-bit integer
74	VO35 Fault Index	16-bit integer
75	VO36 Fault Index	16-bit integer
76	VO37 Fault Index	16-bit integer
77	VO38 Fault Index	16-bit integer
78	VO39 Fault Index	16-bit integer
79	VO40 Fault Index	16-bit integer
80	VO41 Fault Index	16-bit integer
81	VO42 Fault Index	16-bit integer
82	VO43 Fault Index	16-bit integer
83	VO44 Fault Index	16-bit integer
84	VO45 Fault Index	16-bit integer
85	VO46 Fault Index	16-bit integer
86	VO47 Fault Index	16-bit integer
87	VO48 Fault Index	16-bit integer
88	VO49 Fault Index	16-bit integer
89	VO50 Fault Index	16-bit integer
90	VO51 Fault Index	16-bit integer
91	VO52 Fault Index	16-bit integer
92	VO53 Fault Index	16-bit integer
93	VO54 Fault Index	16-bit integer
94	VO55 Fault Index	16-bit integer
95	VO56 Fault Index	16-bit integer
96	VO57 Fault Index	16-bit integer
97	VO58 Fault Index	16-bit integer
98	VO59 Fault Index	16-bit integer
99	VO60 Fault Index	16-bit integer
100	VO61 Fault Index	16-bit integer
101	VO62 Fault Index	16-bit integer
102	VO63 Fault Index	16-bit integer

REG #	WORD NAME	DATA TYPE
103	VO64 Fault Index	16-bit integer
104–105	VO1 Complete Fault Code	32-bit integer
106–107	VO2 Complete Fault Code	32-bit integer
108–109	VO3 Complete Fault Code	32-bit integer
110–111	VO4 Complete Fault Code	32-bit integer
112–113	VO5 Complete Fault Code	32-bit integer
114–115	VO6 Complete Fault Code	32-bit integer
116–117	VO7 Complete Fault Code	32-bit integer
118–119	VO8 Complete Fault Code	32-bit integer
120–121	VO9 Complete Fault Code	32-bit integer
122–123	VO10 Complete Fault Code	32-bit integer
124–125	VO11 Complete Fault Code	32-bit integer
126–127	VO12 Complete Fault Code	32-bit integer
128–129	VO13 Complete Fault Code	32-bit integer
130–131	VO14 Complete Fault Code	32-bit integer
132–133	VO15 Complete Fault Code	32-bit integer
134–135	VO16 Complete Fault Code	32-bit integer
136–137	VO17 Complete Fault Code	32-bit integer
138–139	VO18 Complete Fault Code	32-bit integer
140–141	VO19 Complete Fault Code	32-bit integer
142–143	VO20 Complete Fault Code	32-bit integer
144–145	VO21 Complete Fault Code	32-bit integer
146–147	VO22 Complete Fault Code	32-bit integer
148–149	VO23 Complete Fault Code	32-bit integer
150–151	VO24 Complete Fault Code	32-bit integer
152–153	VO25 Complete Fault Code	32-bit integer
154–155	VO26 Complete Fault Code	32-bit integer
156–157	VO27 Complete Fault Code	32-bit integer
158–159	VO28 Complete Fault Code	32-bit integer
160–161	VO29 Complete Fault Code	32-bit integer
162–163	VO30 Complete Fault Code	32-bit integer
164–165	VO31 Complete Fault Code	32-bit integer
166–167	VO32 Complete Fault Code	32-bit integer
168–169	VO33 Complete Fault Code	32-bit integer
170–171	VO34 Complete Fault Code	32-bit integer
172–173	VO35 Complete Fault Code	32-bit integer
174–175	VO36 Complete Fault Code	32-bit integer
176–177	VO37 Complete Fault Code	32-bit integer
178–179	VO38 Complete Fault Code	32-bit integer
180–181	VO39 Complete Fault Code	32-bit integer

REG #	WORD NAME	DATA TYPE
182–183	VO40 Complete Fault Code	32-bit integer
184–185	VO41 Complete Fault Code	32-bit integer
186–187	VO42 Complete Fault Code	32-bit integer
188–189	VO43 Complete Fault Code	32-bit integer
190–191	VO44 Complete Fault Code	32-bit integer
192–193	VO45 Complete Fault Code	32-bit integer
194–195	VO46 Complete Fault Code	32-bit integer
196–197	VO47 Complete Fault Code	32-bit integer
198–199	VO48 Complete Fault Code	32-bit integer
200–201	VO49 Complete Fault Code	32-bit integer
202–203	VO50 Complete Fault Code	32-bit integer
204–205	VO51 Complete Fault Code	32-bit integer
206–207	VO52 Complete Fault Code	32-bit integer
208–209	VO53 Complete Fault Code	32-bit integer
210–211	VO54 Complete Fault Code	32-bit integer
212–213	VO55 Complete Fault Code	32-bit integer
214–215	VO56 Complete Fault Code	32-bit integer
216–217	VO57 Complete Fault Code	32-bit integer
218–219	VO58 Complete Fault Code	32-bit integer
220–221	VO59 Complete Fault Code	32-bit integer
222–223	VO60 Complete Fault Code	32-bit integer
224–225	VO61 Complete Fault Code	32-bit integer
226–227	VO62 Complete Fault Code	32-bit integer
228–229	VO63 Complete Fault Code	32-bit integer
230–231	VO64 Complete Fault Code	32-bit integer
232–233	Fault #1 Time Stamp	32-bit integer
234–241	Fault #1 Name of I/O or System	2-word length + 12-ASCII characters
242	Fault #1 Error Code	16-bit integer
243	Fault #1 Advanced Error Code	16-bit integer
244	Fault #1 Error Message Index	16-bit integer
245–246	<i>reserved</i>	16-bit integer
247–248	Fault #2 Time Stamp	32-bit integer
249–256	Fault #2 Name of I/O or System	2-word length + 12-ASCII characters
257	Fault #2 Error Code	16-bit integer
258	Fault #2 Advanced Error Code	16-bit integer
259	Fault #2 Error Message Index	16-bit integer
260–261	<i>reserved</i>	16-bit integer
262–263	Fault #3 Time Stamp	32-bit integer
264–271	Fault #3 Name of I/O or System	2-word length + 12-ASCII characters
272	Fault #3 Error Code	16-bit integer

REG #	WORD NAME	DATA TYPE
273	Fault #3 Advanced Error Code	16-bit integer
274	Fault #3 Error Message Index	16-bit integer
275–276	<i>reserved</i>	16-bit integer
277–278	Fault #4 Time Stamp	32-bit integer
279–286	Fault #4 Name of I/O or System	2-word length + 12-ASCII characters
287	Fault #4 Error Code	16-bit integer
288	Fault #4 Advanced Error Code	16-bit integer
289	Fault #4 Error Message Index	16-bit integer
290–291	<i>reserved</i>	16-bit integer
292–293	Fault #5 Time Stamp	32-bit integer
294–301	Fault #5 Name of I/O or System	2-word length + 12-ASCII characters
302	Fault #5 Error Code	16-bit integer
303	Fault #5 Advanced Error Code	16-bit integer
304	Fault #5 Error Message Index	16-bit integer
305–306	<i>reserved</i>	16-bit integer
307–308	Fault #6 Time Stamp	32-bit integer
309–316	Fault #6 Name of I/O or System	2-word length + 12-ASCII characters
317	Fault #6 Error Code	16-bit integer
318	Fault #6 Advanced Error Code	16-bit integer
319	Fault #6 Error Message Index	16-bit integer
320–321	<i>reserved</i>	16-bit integer
322–323	Fault #7 Time Stamp	32-bit integer
324–331	Fault #7 Name of I/O or System	2-word length + 12-ASCII characters
332	Fault #7 Error Code	16-bit integer
333	Fault #7 Advanced Error Code	16-bit integer
334	Fault #7 Error Message Index	16-bit integer
335–336	<i>reserved</i>	16-bit integer
337–338	Fault #8 Time Stamp	32-bit integer
339–346	Fault #8 Name of I/O or System	2-word length + 12-ASCII characters
347	Fault #8 Error Code	16-bit integer
348	Fault #8 Advanced Error Code	16-bit integer
349	Fault #8 Error Message Index	16-bit integer
350–351	<i>reserved</i>	16-bit integer
352–353	Fault #9 Time Stamp	32-bit integer
354–361	Fault #9 Name of I/O or System	2-word length + 12-ASCII characters
362	Fault #9 Error Code	16-bit integer
363	Fault #9 Advanced Error Code	16-bit integer
364	Fault #9 Error Message Index	16-bit integer
365–366	<i>reserved</i>	16-bit integer
367–368	Fault #10 Time Stamp	32-bit integer

REG #	WORD NAME	DATA TYPE
369–376	Fault #10 Name of I/O or System	2-word length + 12-ASCII characters
377	Fault #10 Error Code	16-bit integer
378	Fault #10 Advanced Error Code	16-bit integer
379	Fault #10 Error Message Index	16-bit integer
380–381	<i>reserved</i>	16-bit integer
382–383	Seconds Since Boot	32-bit integer
384	Operating Mode	16-bit integer
385–394	ConfigName	2-word length + 16-ASCII characters
395–396	Config CRC	32-bit integer
397–899	<i>reserved</i>	16-bit integer
900	VO1 – VO16 (see Flags on page 258)	16-bit integer
901	VO17 – VO32 (see Flags on page 258)	16-bit integer
902	VO33 – VO48 (see Flags on page 258)	16-bit integer
903	VO49 – VO64 (see Flags on page 258)	16-bit integer
904	VO65 – VO80 (see Extended Flags on page 259)	16-bit integer
905	VO81 – VO96 (see Extended Flags on page 259)	16-bit integer
906	VO97 – VO112 (see Extended Flags on page 259)	16-bit integer
907	VO113 – VO128 (see Extended Flags on page 259)	16-bit integer
908	VO129 – VO144 (see Extended Flags on page 259)	16-bit integer
909	VO145 – VO160 (see Extended Flags on page 259)	16-bit integer
910	VO161 – VO176 (see Extended Flags on page 259)	16-bit integer
911	VO177 – VO192 (see Extended Flags on page 259)	16-bit integer
912	VO193 – VO208 (see Extended Flags on page 259)	16-bit integer
913	VO209 – VO224 (see Extended Flags on page 259)	16-bit integer
914	VO225 – VO240 (see Extended Flags on page 259)	16-bit integer
915	VO241 – VO256 (see Extended Flags on page 259)	16-bit integer
916	Fault bits for VO1 – VO16 (see Flags on page 258)	16-bit integer
917	Fault bits for VO17 – VO32 (see Flags on page 258)	16-bit integer
918	Fault bits for VO33 – VO48 (see Flags on page 258)	16-bit integer
919	Fault bits for VO49 – VO64 (see Flags on page 258)	16-bit integer
920	Fault bits for VO65 – VO80 (see Extended Flags on page 259)	16-bit integer
921	Fault bits for VO81 – VO96 (see Extended Flags on page 259)	16-bit integer
922	Fault bits for VO97 – VO112 (see Extended Flags on page 259)	16-bit integer
923	Fault bits for VO113 – VO128 (see Extended Flags on page 259)	16-bit integer
924	Fault bits for VO129 – VO144 (see Extended Flags on page 259)	16-bit integer
925	Fault bits for VO145 – VO160 (see Extended Flags on page 259)	16-bit integer
926	Fault bits for VO161 – VO176 (see Extended Flags on page 259)	16-bit integer
927	Fault bits for VO177 – VO192 (see Extended Flags on page 259)	16-bit integer
928	Fault bits for VO193 – VO208 (see Extended Flags on page 259)	16-bit integer
929	Fault bits for VO209 – VO224 (see Extended Flags on page 259)	16-bit integer

REG #	WORD NAME	DATA TYPE
930	Fault bits for VO225 – VO240 (see Extended Flags on page 259)	16-bit integer
931	Fault bits for VO241 – VO256 (see Extended Flags on page 259)	16-bit integer
932	Virtual Reset/Cancel Delay (1–16) Feedback [RCD Feedback Register Bits] (see Virtual Manual Reset and Cancel Delay (RCD) Sequence on page 61)	16-bit integer
933	<i>reserved</i>	16-bit integer
934	RCD Actuation Code Feedback [RCD Enable Feedback Register] (see Virtual Manual Reset and Cancel Delay (RCD) Sequence on page 61)	16-bit integer

Table 43: N20 REGS

REG #	WORD NAME	DATA TYPE
1	VO1 Fault Index	16-bit integer
2	VO2 Fault Index	16-bit integer
3	VO3 Fault Index	16-bit integer
...
256	VO256 Fault Index	16-bit integer
257-258	VO1 Complete Fault Code	32-bit integer
259-260	VO2 Complete Fault Code	32-bit integer
261-262	VO3 Complete Fault Code	32-bit integer
263-264	VO4 Complete Fault Code	32-bit integer
...
767-768	VO256 Complete Fault Code	32-bit integer
769-770	ISD System Status – Chain 1 Device Count	32-bit integer
771-772	ISD System Status – Chain 2 Device Count	32-bit integer
773-774	ISD System Status – Chain 1 Device On/Off Status (see ISD System Status Words on page 206)	32-bit integer
775-776	ISD System Status – Chain 2 Device On/Off Status (see ISD System Status Words on page 206)	32-bit integer
777-778	ISD System Status – Chain 1 Fault Status (see ISD System Status Words on page 206)	32-bit integer
779-780	ISD System Status – Chain 2 Fault Status (see ISD System Status Words on page 206)	32-bit integer
781-782	ISD System Status – Chain 1 Marginal Status (see ISD System Status Words on page 206)	32-bit integer
783-784	ISD System Status – Chain 2 Marginal Status (see ISD System Status Words on page 206)	32-bit integer
785-786	ISD System Status – Chain 1 Alert Status (see ISD System Status Words on page 206)	32-bit integer
787-788	ISD System Status – Chain 2 Alert Status (see ISD System Status Words on page 206)	32-bit integer
789-790	ISD System Status – Chain 1 Reset Status (see ISD System Status Words on page 206)	32-bit integer
791-792	ISD System Status – Chain 2 Reset Status (see ISD System Status Words on page 206)	32-bit integer

REG #	WORD NAME	DATA TYPE
793-794	ISD System Status – Chain 1 Actuator Recognized (see ISD System Status Words on page 206)	32-bit integer
795-796	ISD System Status – Chain 2 Actuator Recognized (see ISD System Status Words on page 206)	32-bit integer
797-798	ISD System Status – Chain 1 System Status (see ISD Chain System Status on page 50)	32-bit integer
799-800	ISD System Status – Chain 2 System Status (see ISD Chain System Status on page 50)	32-bit integer
801-816	List of Detected ISD Devices on a Chain	Array of 32 bytes
817-833	<i>reserved</i>	16-bit integer
834	ISD Read Request Acknowledge (see Request Performance and Status Information about an Individual Device via ISD on page 50)	16-bit integer
835	ISD Chain Requested Acknowledge (see Request Performance and Status Information about an Individual Device via ISD on page 50)	16-bit integer
836	ISD Device Requested Acknowledge (see Request Performance and Status Information about an Individual Device via ISD on page 50)	16-bit integer
837-845	ISD Individual Device-Specific Data ⁴⁸ (see ISD Individual Device-Specific Data Detailed Description on page 257)	16-bit integer
846-848	<i>reserved</i>	16-bit integer
849-850	ISD System Status – Chain 1 Device Count	32-bit integer
851-852	ISD System Status – Chain 1 Device On/Off Status (see ISD System Status Words on page 206)	32-bit integer
853-854	ISD System Status – Chain 1 Fault Status (see ISD System Status Words on page 206)	32-bit integer
855-856	ISD System Status – Chain 1 Marginal Status (see ISD System Status Words on page 206)	32-bit integer
857-858	ISD System Status – Chain 1 Alert Status (see ISD System Status Words on page 206)	32-bit integer
859-860	ISD System Status – Chain 1 Reset Status (see ISD System Status Words on page 206)	32-bit integer
861-862	ISD System Status – Chain 1 Actuator Recognized Status (see ISD System Status Words on page 206)	32-bit integer
863-864	ISD System Status – Chain 1 System Status (see ISD Chain System Status on page 50)	32-bit integer
865-866	ISD System Status – Chain 2 Device Count	32-bit integer
867-868	ISD System Status – Chain 2 Device On/Off Status (see ISD System Status Words on page 206)	32-bit integer
869-870	ISD System Status – Chain 2 Fault Status (see ISD System Status Words on page 206)	32-bit integer
871-872	ISD System Status – Chain 2 Marginal Status (see ISD System Status Words on page 206)	32-bit integer
873-874	ISD System Status – Chain 2 Alert Status (see ISD System Status Words on page 206)	32-bit integer
875-876	ISD System Status – Chain 2 Reset Status (see ISD System Status Words on page 206)	32-bit integer

⁴⁸ For conversion to Internal Temperature, Actuator Distance, and Supply Voltage, see [ISD: Temperature, Voltage, and Distance Conversion Information](#) on page 296.

REG #	WORD NAME	DATA TYPE
877-878	ISD System Status – Chain 2 Actuator Recognized Status (see ISD System Status Words on page 206)	32-bit integer
879-880	ISD System Status – Chain 2 System Status (see ISD Chain System Status on page 50)	32-bit integer
881-882	ISD System Status – Chain 3 Device Count	32-bit integer
883-884	ISD System Status – Chain 3 Device On/Off Status (see ISD System Status Words on page 206)	32-bit integer
885-886	ISD System Status – Chain 3 Fault Status (see ISD System Status Words on page 206)	32-bit integer
887-888	ISD System Status – Chain 3 Marginal Status (see ISD System Status Words on page 206)	32-bit integer
889-890	ISD System Status – Chain 3 Alert Status (see ISD System Status Words on page 206)	32-bit integer
891-892	ISD System Status – Chain 3 Reset Status (see ISD System Status Words on page 206)	32-bit integer
893-894	ISD System Status – Chain 3 Actuator Recognized Status (see ISD System Status Words on page 206)	32-bit integer
895-896	ISD System Status – Chain 3 System Status (see ISD Chain System Status on page 50)	32-bit integer
897-898	ISD System Status – Chain 4 Device Count	32-bit integer
899-900	ISD System Status – Chain 4 Device On/Off Status (see ISD System Status Words on page 206)	32-bit integer
901-902	ISD System Status – Chain 4 Fault Status (see ISD System Status Words on page 206)	32-bit integer
903-904	ISD System Status – Chain 4 Marginal Status (see ISD System Status Words on page 206)	32-bit integer
905-906	ISD System Status – Chain 4 Alert Status (see ISD System Status Words on page 206)	32-bit integer
907-908	ISD System Status – Chain 4 Reset Status (see ISD System Status Words on page 206)	32-bit integer
909-910	ISD System Status – Chain 4 Actuator Recognized Status (see ISD System Status Words on page 206)	32-bit integer
911-912	ISD System Status – Chain 4 System Status (see ISD Chain System Status on page 50)	32-bit integer
913-914	ISD System Status – Chain 5 Device Count	32-bit integer
915-916	ISD System Status – Chain 5 Device On/Off Status (see ISD System Status Words on page 206)	32-bit integer
917-918	ISD System Status – Chain 5 Fault Status (see ISD System Status Words on page 206)	32-bit integer
919-920	ISD System Status – Chain 5 Marginal Status (see ISD System Status Words on page 206)	32-bit integer
921-922	ISD System Status – Chain 5 Alert Status (see ISD System Status Words on page 206)	32-bit integer
923-924	ISD System Status – Chain 5 Reset Status (see ISD System Status Words on page 206)	32-bit integer
925-926	ISD System Status – Chain 5 Actuator Recognized Status (see ISD System Status Words on page 206)	32-bit integer
927-928	ISD System Status – Chain 5 System Status (see ISD Chain System Status on page 50)	32-bit integer

REG #	WORD NAME	DATA TYPE
929-930	ISD System Status – Chain 6 Device Count	32-bit integer
931-932	ISD System Status – Chain 6 Device On/Off Status (see ISD System Status Words on page 206)	32-bit integer
933-934	ISD System Status – Chain 6 Fault Status (see ISD System Status Words on page 206)	32-bit integer
935-936	ISD System Status – Chain 6 Marginal Status (see ISD System Status Words on page 206)	32-bit integer
937-938	ISD System Status – Chain 6 Alert Status (see ISD System Status Words on page 206)	32-bit integer
939-940	ISD System Status – Chain 6 Reset Status (see ISD System Status Words on page 206)	32-bit integer
941-942	ISD System Status – Chain 6 Actuator Recognized Status (see ISD System Status Words on page 206)	32-bit integer
943-944	ISD System Status – Chain 6 System Status (see ISD Chain System Status on page 50)	32-bit integer
945-946	ISD System Status – Chain 7 Device Count	32-bit integer
947-948	ISD System Status – Chain 7 Device On/Off Status (see ISD System Status Words on page 206)	32-bit integer
949-950	ISD System Status – Chain 7 Fault Status (see ISD System Status Words on page 206)	32-bit integer
951-952	ISD System Status – Chain 7 Marginal Status (see ISD System Status Words on page 206)	32-bit integer
953-954	ISD System Status – Chain 7 Alert Status (see ISD System Status Words on page 206)	32-bit integer
955-956	ISD System Status – Chain 7 Reset Status (see ISD System Status Words on page 206)	32-bit integer
957-958	ISD System Status – Chain 7 Actuator Recognized Status (see ISD System Status Words on page 206)	32-bit integer
959-960	ISD System Status – Chain 7 System Status (see ISD Chain System Status on page 50)	32-bit integer
961-962	ISD System Status – Chain 8 Device Count	32-bit integer
963-964	ISD System Status – Chain 8 Device On/Off Status (see ISD System Status Words on page 206)	32-bit integer
965-966	ISD System Status – Chain 8 Fault Status (see ISD System Status Words on page 206)	32-bit integer
967-968	ISD System Status – Chain 8 Marginal Status (see ISD System Status Words on page 206)	32-bit integer
969-970	ISD System Status – Chain 8 Alert Status (see ISD System Status Words on page 206)	32-bit integer
971-972	ISD System Status – Chain 8 Reset Status (see ISD System Status Words on page 206)	32-bit integer
973-974	ISD System Status – Chain 8 Actuator Recognized Status (see ISD System Status Words on page 206)	32-bit integer
975-976	ISD System Status – Chain 8 System Status (see ISD Chain System Status on page 50)	32-bit integer

 **Note:**

- See [ISD Individual Device-Specific Data](#) on page 51 for more information of the structure of the ISD data.
- The ISD data is not immediately available upon power up. The ISD data can be delayed up to 10 seconds after the system power has been turned on.

ISD Individual Device-Specific Data Detailed Description

The following table describes N20 REG #837-845.

Table 44: ISD Individual Device-Specific Data Detailed Description

REG #	Information	Data size
837.0	Safety Input Fault	1 bit
837.1	<i>reserved</i>	1 bit
837.2	Sensor Not Paired	1-bit
837.3	ISD Data Error	1-bit
837.4	Wrong Actuator/Button Status/Input Status	1-bit
837.5	Marginal Range/Button Status/Input Status	1-bit
837.6	Actuator Detected	1-bit
837.7	Output Error	1-bit
837.8	Input 2	1-bit
837.9	Input 1	1-bit
837.10	Local Reset Expected	1-bit
837.11	Operating Voltage Warning	1-bit
837.12	Operating Voltage Error	1-bit
837.13	Output 2	1-bit
837.14	Output 1	1-bit
837.15	Power Cycle Required	1-bit
838.0	Fault Tolerant Outputs	1-bit
838.1	Local Reset Unit	1-bit
838.2	Cascadable	1-bit
838.3	High Coding Level	1-bit
838.4 to 838.7	Teach-ins Remaining	4-bit
838.8 to 838.12	Device ID	5-bit
838.13 to 839.2	Range Warning Count	6-bit
839.3 to 839.7	Output Switch-off Time	5-bit
839.8 to 839.15	Number of Voltage Errors	8-bit
840.0 to 840.7	Internal Temperature ⁴⁹	8-bit
840.8 to 840.15	Actuator Distance ⁴⁹	8-bit
841.0 to 841.7	Supply Voltage ⁴⁹	8-bit
841.8 to 841.11	Expected Company Name	4-bit
841.12 to 841.15	Received Company Name	4-bit
842	Expected Code	16-bit

⁴⁹ For conversion to Internal Temperature, Actuator Distance, and Supply Voltage, see [ISD: Temperature, Voltage, and Distance Conversion Information](#) on page 296.

REG #	Information	Data size
843	Received Code	16-bit
844	Internal Error A	16-bit
845	Internal Error B	16-bit



Note: See [ISD Individual Device-Specific Data](#) on page 51 for more information of the structure of the ISD data.

12.6.3 Inputs to Safety Controller (Outputs from PLC)

The Input registers are used to send information to the Safety Controller from the PLC. MSG (message) commands are used to write (N11, N21) to the Safety Controller.

Table 45: N11 REGS

REG #	WORD NAME	DATA TYPE
0–7	<i>reserved</i>	16-bit integer
8	Virtual Input On/Off (1–16)	16-bit integer
9	Virtual Input On/Off (17–32)	16-bit integer
10	Virtual Input On/Off (33–48)	16-bit integer
11	Virtual Input On/Off (49–64)	16-bit integer
12–15	<i>reserved</i>	16-bit integer
16	Virtual Reset/Cancel Delay (1–16) [RCD Register Bits] (see Virtual Manual Reset and Cancel Delay (RCD) Sequence on page 61)	16-bit integer
17	<i>reserved</i>	16-bit integer
18	RCD Actuation Code [RCD Enable Register] (see Virtual Manual Reset and Cancel Delay (RCD) Sequence on page 61)	16-bit integer

Table 46: N21 REGS

REG #	WORD NAME	DATA TYPE
1	ISD Read Request (see Request Performance and Status Information about an Individual Device via ISD on page 50)	16-bit integer
2	ISD Chain Requested (see Request Performance and Status Information about an Individual Device via ISD on page 50)	16-bit integer
3	ISD Device Requested (see Request Performance and Status Information about an Individual Device via ISD on page 50)	16-bit integer

12.6.4 Flags

Registers 0 through 7, defined below, appear as the first 8 words in the N7 register map.

Table 47: Register #0, Virtual Output 1-16, Bit Position

Bit Position															
15	14	13	12	11	10	9	8	7	6	5	4	3	2	1	0
VO16	VO15	VO14	VO13	VO12	VO11	VO10	VO9	VO8	VO7	VO6	VO5	VO4	VO3	VO2	VO1

Table 48: Register #1, Virtual Output 17-32, Bit Position

Bit Position															
15	14	13	12	11	10	9	8	7	6	5	4	3	2	1	0
VO32	VO31	VO30	VO29	VO28	VO27	VO26	VO25	VO24	VO23	VO22	VO21	VO20	VO19	VO18	VO17

Table 49: Register #2, Virtual Output 33-48, Bit Position

Bit Position															
15	14	13	12	11	10	9	8	7	6	5	4	3	2	1	0
VO48	VO47	VO46	VO45	VO44	VO43	VO42	VO41	VO40	VO39	VO38	VO37	VO36	VO35	VO34	VO33

Table 50: Register #3, Virtual Output 49-64, Bit Position

Bit Position															
15	14	13	12	11	10	9	8	7	6	5	4	3	2	1	0
VO64	VO63	VO62	VO61	VO60	VO59	VO58	VO57	VO56	VO55	VO54	VO53	VO52	VO51	VO50	VO49

Table 51: Register #4, Fault Flag bits for Virtual Output 1-16, Bit Position

Note that not every Virtual Output has a defined Fault Flag.

Bit Position															
15	14	13	12	11	10	9	8	7	6	5	4	3	2	1	0
VO16	VO15	VO14	VO13	VO12	VO11	VO10	VO9	VO8	VO7	VO6	VO5	VO4	VO3	VO2	VO1

Table 52: Register #5, Fault Flag bits for Virtual Output 17-32 Fault Flag, Bit Position

Note that not every Virtual Output has a defined Fault Flag.

Bit Position															
15	14	13	12	11	10	9	8	7	6	5	4	3	2	1	0
VO32	VO31	VO30	VO29	VO28	VO27	VO26	VO25	VO24	VO23	VO22	VO21	VO20	VO19	VO18	VO17

Table 53: Register #6, Fault Flag bits for Virtual Output 33-48, Bit Position

Note that not every Virtual Output has a defined Fault Flag.

Bit Position															
15	14	13	12	11	10	9	8	7	6	5	4	3	2	1	0
VO48	VO47	VO46	VO45	VO44	VO43	VO42	VO41	VO40	VO39	VO38	VO37	VO36	VO35	VO34	VO33

Table 54: Register #7, Fault Flag bits for Virtual Output 49-64, Bit Position

Note that not every Virtual Output has a defined Fault Flag.

Bit Position															
15	14	13	12	11	10	9	8	7	6	5	4	3	2	1	0
VO64	VO63	VO62	VO61	VO60	VO59	VO58	VO57	VO56	VO55	VO54	VO53	VO52	VO51	VO50	VO49

12.6.5 Extended Flags

All 256 Virtual Outputs can be accessed in a way similar to that seen in [Flags](#) on page 258.

All 256 possible Virtual Outputs can be read as Registers 900-915.

All 256 possible Virtual Output Faults can be read as Registers 916-931.

12.7 PROFINET®

PROFINET®⁵⁰ is a data communication protocol for industrial automation and processes. PROFINET IO defines how controllers (IO controllers) and peripheral devices (IO devices) exchange data in real time.

The Banner Safety Controller supports PROFINET IO. The data communication protocol is TCP/IP; the data transmission medium is copper wire; the PROFINET conformance class is CC-A.⁵¹



Note: In this document, outputs from the Safety Controller device are referred to as "inputs" to the controller (PLC). Outputs from the controller (PLC) are referred to as "inputs" to the Safety Controller device.

⁵⁰ PROFINET® is a registered trademark of PROFIBUS Nutzerorganisation e.V.

⁵¹ CC-A ensures that the device has the minimum properties regarding functionality and interoperability.

12.7.1 PROFINET® and the Safety Controllers

This section covers instructions for XS/SC26 Safety Controllers with the FID 2 designation on the product label and a date code of 1706 or later, and also FID 3 and later XS/SC26 Safety Controllers.

This section also covers the SC10-2.

PROFINET real time data is sent and received via slots.



Note: The GSD file is available for download at www.bannerengineering.com/safetycontroller.

12.7.2 General Station Description (GSD) File

The General Station Description (GSD) file contains module information, such as:

- Configuration data
- Data information (pass count, inspection status, etc.)
- Diagnostics

12.7.3 PROFINET® IO Data Model

The PROFINET IO data model is based on the typical, expandable field device that has a backplane with slots. Modules and submodules have different functionalities.

Modules are plugged into slots; submodules are plugged into subslots. In the PROFINET IO data model, Slot 0 Subslot 1 is reserved for the Device Access Point (DAP) or network interface.

Both modules and submodules are used to control the type and volume of data that is sent to the controller (PLC).

- A submodule is typically designated as input type, output type, or combined input/output type
- An input submodule is used to send data to the controller (PLC)
- An output submodule is used to receive data from the controller (PLC)
- The combined input/output submodule simultaneously receives and sends data in both directions

12.7.4 Configuring the Safety Controller for a PROFINET IO Connection

1. Connect the Safety Controller to the PC via the SC-USB2 USB cable.
2. Open the Banner Safety Controller Software, and click the **Industrial Ethernet** tab.
3. From the drop-down list on the left, select **Profinet**.
4. Click  to add information to the PROFINET Submodules.
Auto Configure can assist in this task.
5. Provide the appropriate password to change the configuration and network settings for the Safety Controller.
6. Make sure the Safety Controller has a valid and confirmed configuration file.



Note: If a Virtual Reset or Cancel Delay is used, an Actuation Code must be created in **Network Settings**. Then the code must be sent to the Safety Controller using **Send** in **Network Settings**.



Note: The ClickSet IP process does not apply to PROFINET, because the IP address is set by the PLC system not by the Controller software.

12.7.5 Create a XML File For PROFINET

Several items must be known:

- The name assigned to the Safety Controller in the PLC. This is needed to generate the file to import into the PROFINET PLC software
- PLC Slot 1 address location
- PLC Slot 13 address location
- PLC Slot 20 or PLC Slot 22 address location
- PLC Slot 21 address location
- PLC Slot 23 address location

This information is available in the PLC Software. The following figure is an example from Siemens TIA Portal (v15) software.

Figure 252. Device overview

Module	Rack	Slot	I address	Q address	Type
xs26 ¹	0	0			XS26
I	0	0 X1			xs26
4 Status Bytes, Bits 0..31_1	0	1	2...5 ²		4 Status Bytes, Bits 0..31
4 Status Bytes, Bits 0..31_2	0	2	6...9		4 Status Bytes, Bits 0..31
4 Status Bytes, Bits 0..31_3	0	3	10...13		4 Status Bytes, Bits 0..31
4 Status Bytes, Bits 0..31_4	0	4	14...17		4 Status Bytes, Bits 0..31
4 Status Bytes, Bits 0..31_5	0	5	18...21		4 Status Bytes, Bits 0..31
4 Status Bytes, Bits 0..31_6	0	6	22...25		4 Status Bytes, Bits 0..31
4 Status Bytes, Bits 0..31_7	0	7	26...29		4 Status Bytes, Bits 0..31
4 Status Bytes, Bits 0..31_8	0	8	30...33		4 Status Bytes, Bits 0..31
4 Status Bytes, Bits 0..31_9	0	9	34...37		4 Status Bytes, Bits 0..31
4 Status Bytes, Bits 0..31_10	0	10	38...41		4 Status Bytes, Bits 0..31
4 Status Bytes, Bits 0..31_11	0	11	42...45		4 Status Bytes, Bits 0..31
4 Status Bytes, Bits 0..31_12	0	12	46...49		4 Status Bytes, Bits 0..31
8 Bytes Virtual On/Off/IME Data_1	0	13		2...9 ³	8 Bytes Virtual On/Off/IME Data
2 Bytes RCD Data_1	0	14		10...11	2 Bytes RCD Data
2 Byte RCD Acutation Code_1	0	15		12...13	2 Byte RCD Acutation Code
RCD Data Feedback Register_1	0	16	50...51		RCD Data Feedback Register
RCD Passcode Feedback Register_1	0	17	52...53		RCD Passcode Feedback Register
	0	18			
System Information Module_1	0	19	54...83		System Information Module
	0	20			
ISD Individual Status Information Module_1	0	21			ISD Individual Status Information Module
ISD Device Information Request	0	21 IS...		14...19 ^{4b}	ISD Device Information Request
ISD Device Information Response	0	21 IS...	372...395 ^{4a}		ISD Device Information Response
ISD Status Information Module 8 Chain_1	0	22 ⁵	84...339		ISD Status Information Module 8 Chain
ISD Specific Chain Information Module_1	0	23	340...371 ⁶		ISD Specific Chain Information Module

Note: Slot 20, 21, 22 and 23 are for ISD information, and are only available after ISD inputs have been configured (SC10-2 FID 2 or later, XS26-ISD FID 5 or later). Slot 22 is not available with SC10-2 configurations.

1. In the Banner Safety Controller software, on the **Industrial Ethernet** tab, make sure **Profinet** is selected from the list at the left.
2. Click **Export**.
The **Export to XML** window opens.

Figure 253. Export to XML—XS26-ISD Image Shown

The numbers in this figure correspond to the numbers in Figure 252 on page 261.

3. Enter the information in the window.
 - a) In the **Controller Name** field, enter the name assigned to the Safety Controller in the PLC software. See item 1 in Figure 252 on page 261. In this example it is xs26.
 - b) In the **PLC Slot 1 Address Location** field, enter the beginning address location of slot 1 (status outputs). See item 2 in Figure 252 on page 261. In this example, it is 2.
 - c) In the **PLC Slot 13 Address Location** field, enter the beginning address location of slot 13 (virtual inputs). See item 3 in Figure 252 on page 261. In this example, it is 2.

4. Enter the optional information in the window. These fields must be blank if they are not used.
 - a) SC10-2 models: In the **PLC Slot 20 Address Location** field, enter the beginning address location of slot 20 (ISD Status Information Module 4 Chain).
 - b) XS26-ISD models: From the drop down menu, select one of the following:
 - **PLC Slot 20 Address Location** for ISD Status Information Module 4 Chain (this is not shown in [Figure 252](#) on page 261).
 - **PLC Slot 22 Address Location** for ISD status Information Module 8 Chain (see item 5 in [Figure 252](#) on page 261). In this example, it is 84.
 - c) XS26-ISD models: In the **PLC Slot 21 Address Location** field, enter the beginning address location of slot 21 (ISD Individual Device Information Module). See items 4a and 4b in [Figure 252](#) on page 261. In this example it is 372 and 14.
 - d) XS26-ISD models: In the **PLC Slot 23 Address Location** field, enter the beginning address location of slot 23 (ISD Specific Chain Information Module), See item 6 in [Figure 252](#) on page 261. In this example it is 340.
5. Click **Export**.
6. Save the .xml file to the desired location.

The .xml file is ready to be directly imported into the PROFINET PLC software or the file can be opened with any software that can read an .xml file.

12.7.6 Description of Modules

Table 55: Assignment of Slots

In this table, the I/O direction is from the point of view of the PLC.

Slot	Module Function	I/O	Module Name	Module Size (Bytes)
1	User-Defined Status Bits (0–31)	In	4 Status Bytes, Bits 0..31_1	4
2	User-Defined Status Bits (32–63)	In	4 Status Bytes, Bits 0..31_2	4
3	Safety Controller Fault Bits (0–31)	In	4 Status Bytes, Bits 0..31_3	4
4	Safety Controller Fault Bits (32–63)	In	4 Status Bytes, Bits 0..31_4	4
5	Safety Controller Input Status Bits (0–31)	In	4 Status Bytes, Bits 0..31_5	4
6	Safety Controller Input Status Bits (32–63)	In	4 Status Bytes, Bits 0..31_6	4
7	Safety Controller Input Status Bits (64–95)	In	4 Status Bytes, Bits 0..31_7	4
8	Safety Controller Input Status Bits (96–127)	In	4 Status Bytes, Bits 0..31_8	4
9	Safety Controller Input Status Bits (128–159)	In	4 Status Bytes, Bits 0..31_9	4
10	Safety Controller Output Status Bits (0–31)	In	4 Status Bytes, Bits 0..31_10	4
11	Safety Controller Output Status Bits (32–63)	In	4 Status Bytes, Bits 0..31_11	4
12	Safety Controller Output Status Bits (64–95)	In	4 Status Bytes, Bits 0..31_12	4
13	Virtual I/O (On/Off/Mute Enable) Bits (0–63)	Out	8 Bytes Virtual On/Off/ME Data_1	8
14	Virtual Reset, Cancel Delay Bits (0–16)	Out	2 Bytes RCD Data_1	2
15	Reset, Cancel Delay Actuation Code	Out	2 Byte RCD Actuation Code_1	2
16	Virtual Reset, Cancel Delay Bits (0–16) Feedback	In	RCD Data Feedback Register_1	2
17	Reset, Cancel Delay Actuation Code Feedback	In	RCD Passcode Feedback Register_1	2
18 ⁵²	Fault Log	In	Fault Log Buffer Module	300

⁵² The Fault Log and System Information Modules are not used by the default connection.

Slot	Module Function	I/O	Module Name	Module Size (Bytes)
19 ⁵²	System Information	In	System Information Module	30
20	ISD Status (4 chains)	In	ISD Status Information Module 4 Chain	128
21	ISD Individual Device Information	In/Out	ISD Individual Status Information Module	24 In/6 Out
22	ISD Status (8 chains)	In	ISD Status Information Module 8 Chain	256
23	List of Detected ISD Devices on a Chain	In	ISD Specific Chain Information Module	32

**Note:**

- See [ISD Individual Device-Specific Data](#) on page 51 for more information on the structure of the ISD data.
- The ISD data is not immediately available upon power up. The ISD data can be delayed up to 10 seconds after the system power has been turned on.

User-Defined Status Bits

The first two slots are always filled with User Defined Status Bit modules. These modules include 64 bits worth of virtual status output information of any type.

Table 56: User-Defined Status Bits (0–31) Module (Ident 0×0100) [fixed in Slot 1]

PLC Input Data Name	Input Data Type	PLC Output Data Name	Output Data Type
User-Defined Status bits 0–7	Byte	Not applicable	Not applicable
User-Defined Status bits 8–15	Byte		
User-Defined Status bits 16–23	Byte		
User-Defined Status bits 24–31	Byte		

Table 57: User-Defined Status Bits (32–63) Module (Ident 0×0100) [fixed in Slot 2]

PLC Input Data Name	Input Data Type	PLC Output Data Name	Output Data Type
User-Defined Status bits 32–39	Byte	Not applicable	Not applicable
User-Defined Status bits 40–47	Byte		
User-Defined Status bits 48–55	Byte		
User-Defined Status bits 56–63	Byte		

Fault Bits

Slots 3 and 4 are always filled with 64-bits of Fault type virtual status output information from the Safety Controller.

Table 58: Safety Controller Fault Bits (0–31) Module (Ident 0×0100) [fixed in Slot 3]

PLC Input Data Name	Input Data Type	PLC Output Data Name	Output Data Type
Fault bits 0–7	Byte	Not applicable	Not applicable
Fault bits 8–15	Byte		
Fault bits 16–23	Byte		
Fault bits 24–31	Byte		

Table 59: Safety Controller Fault Bits (32–63) Module (Ident 0×0100) [fixed in Slot 4]

PLC Input Data Name	Input Data Type	PLC Output Data Name	Output Data Type
Fault bits 32–39	Byte	Not applicable	Not applicable
Fault bits 40–47	Byte		
Fault bits 48–55	Byte		
Fault bits 56–63	Byte		

Input Status Bits

Slots 5 through 9 are always reserved for 160 bits of Safety Controller input information. An expandable Safety Controller might have up to 154 inputs, if all of eight possible expansion cards were used as 16-channel inputs (in addition to the 26 inputs built into the Base Controller).

Table 60: Safety Controller Input Status Bits (0–31) Module (Ident 0×1000) [fixed in Slot 5]

PLC Input Data Name	Input Data Type	PLC Output Data Name	Output Data Type
Input Status bits 0–7	Byte	Not applicable	Not applicable
Input Status bits 8–15	Byte		
Input Status bits 16–23	Byte		
Input Status bits 24–31	Byte		

Table 61: Safety Controller Input Status Bits (32–63) Module (Ident 0×0100) [fixed in Slot 6]

PLC Input Data Name	Input Data Type	PLC Output Data Name	Output Data Type
Input Status bits 32–39	Byte	Not applicable	Not applicable
Input Status bits 40–47	Byte		
Input Status bits 48–55	Byte		
Input Status bits 56–63	Byte		

Table 62: Safety Controller Input Status Bits (64–95) Module (Ident 0×0100) [fixed in Slot 7]

PLC Input Data Name	Input Data Type	PLC Output Data Name	Output Data Type
Input Status bits 64–71	Byte	Not applicable	Not applicable
Input Status bits 72–79	Byte		
Input Status bits 80–87	Byte		
Input Status bits 88–95	Byte		

Table 63: Safety Controller Input Status Bits (96–127) Module (Ident 0×0100) [fixed in Slot 8]

PLC Input Data Name	Input Data Type	PLC Output Data Name	Output Data Type
Input Status bits 96–103	Byte	Not applicable	Not applicable
Input Status bits 104–111	Byte		
Input Status bits 112–119	Byte		
Input Status bits 120–127	Byte		

Table 64: Safety Controller Input Status Bits (128–159) Module (Ident 0×0100) [fixed in Slot 9]

PLC Input Data Name	Input Data Type	PLC Output Data Name	Output Data Type
Input Status bits 128–135	Byte	Not applicable	Not applicable
Input Status bits 136–143	Byte		
Input Status bits 144–151	Byte		
Input Status bits 152–159	Byte		

Output Status Bits

Slots 10 through 12 are reserved for 96 Safety Controller output type virtual status output bits.

Table 65: Safety Controller Output Status Bits (0–31) Module (Ident 0×0100) [fixed in Slot 10]

PLC Input Data Name	Input Data Type	PLC Output Data Name	Output Data Type
Output Status bits 0–7	Byte	Not applicable	Not applicable
Output Status bits 8–15	Byte		
Output Status bits 16–23	Byte		
Output Status bits 24–31	Byte		

Table 66: Safety Controller Output Status Bits (32–63) Module (Ident 0×0100) [fixed in Slot 11]

PLC Input Data Name	Input Data Type	PLC Output Data Name	Output Data Type
Output Status bits 32–39	Byte	Not applicable	Not applicable
Output Status bits 40–47	Byte		
Output Status bits 48–55	Byte		
Output Status bits 56–63	Byte		

Table 67: Safety Controller Output Status Bits (64–95) Module (Ident 0×0100) [fixed in Slot 12]

PLC Input Data Name	Input Data Type	PLC Output Data Name	Output Data Type
Output Status bits 64–71	Byte	Not applicable	Not applicable
Output Status bits 72–79	Byte		
Output Status bits 80–87	Byte		
Output Status bits 88–95	Byte		

Virtual On, Off, Mute Enable Bits

Slot 13 is filled with 64 virtual non-safety inputs, to be used as virtual on/off inputs (to the Safety Controller) or virtual mute enable inputs (to the Safety Controller).

Table 68: Virtual On/Off/Mute Enable Bits (0–63) Module (Ident 0×0200) [fixed in Slot 13]

PLC Input Data Name	Input Data Type	PLC Output Data Name	Output Data Type
Not applicable	Not applicable	Virtual On/Off/ME bits 0–7	Byte
		Virtual On/Off/ME bits 8–15	Byte
		Virtual On/Off/ME bits 16–23	Byte
		Virtual On/Off/ME bits 24–31	Byte
		Virtual On/Off/ME bits 32–39	Byte
		Virtual On/Off/ME bits 40–47	Byte
		Virtual On/Off/ME bits 48–55	Byte
		Virtual On/Off/ME bits 56–63	Byte

Virtual Reset, Cancel Delay (VRCD) Bits

Sixteen virtual non-safety inputs can be found in slot 14, to be used in the virtual reset, cancel delay sequence.

See [Virtual Manual Reset and Cancel Delay \(RCD\) Sequence](#) on page 61.

Table 69: Virtual Reset, Cancel Delay Bits (0–63) Module (Ident 0×0300) [fixed in Slot 14]

PLC Input Data Name	Input Data Type	PLC Output Data Name	Output Data Type
Not applicable	Not applicable	VRCD bits 0-7	Byte
		VRCD bits 8-15	Byte

Reset, Cancel Delay (RCD) 16-bit Actuation Code

Slot 15 contains the RCD Actuation Code, an important code word used in the virtual reset, cancel delay sequence.

See [Virtual Manual Reset and Cancel Delay \(RCD\) Sequence](#) on page 61.

Table 70: Reset, Cancel Delay Actuation Code Module (Ident 0×0301) [fixed in Slot 15]

PLC Input Data Name	Input Data Type	PLC Output Data Name	Output Data Type
Not applicable	Not applicable	Reset, Cancel Delay Actuation Code	Unsigned 16

Virtual Reset, Cancel Delay Feedback Bits

Slot 16 includes feedback bits for the 16 virtual non-safety inputs found in slot 14. They are used in the virtual reset, cancel delay sequence.

See [Virtual Manual Reset and Cancel Delay \(RCD\) Sequence](#) on page 61.

Table 71: Virtual Reset, Cancel Delay Bits (0–63) Module (Ident 0×0400) [fixed in Slot 16]

PLC Input Data Name	Input Data Type	PLC Output Data Name	Output Data Type
VRCD Feedback bits 0–7	Byte	Not applicable	Not applicable
VRCD Feedback bits 8–15	Byte		

Reset, Cancel Delay 16-bit Actuation Code Feedback

Slot 17 includes the RCD Actuation Code feedback value, an important code word used in the virtual reset, cancel delay sequence.

See [Virtual Manual Reset and Cancel Delay \(RCD\) Sequence](#) on page 61.

Table 72: Reset, Cancel Delay Actuation Code Module (Ident 0x0401) [fixed in Slot 17]

PLC Input Data Name	Input Data Type	PLC Output Data Name	Output Data Type
Reset, Cancel Delay Actuation Code Feedback	Unsigned 16	Not applicable	Not applicable

Fault Log Entries

Slot 18 can be filled with the optional Fault Log Buffer Module.

Table 73: Safety Controller Fault Log Buffer Module (Ident 0x0500) [optional; fixed in Slot 18 when used]

PLC Input Data Name	Input Data Type	PLC Output Data Name	Output Data Type
Fault Log entry 1 (most recent)	15 words	Not applicable	Not applicable
Fault Log entry 2	15 words		
Fault Log entry 3	15 words		
Fault Log entry 4	15 words		
Fault Log entry 5	15 words		
Fault Log entry 6	15 words		
Fault Log entry 7	15 words		
Fault Log entry 8	15 words		
Fault Log entry 9	15 words		
Fault Log entry 10 (oldest)	15 words		

Fault Log Entry	Type	Length (Words)
Timestamp	UDINT	2
Name Length	DWORD	2
Name String	String	6
Error Code	WORD	1
Advanced Error Code	WORD	1
Error Index Message	WORD	1
<i>reserved</i>	WORD	2

Fault Time Stamp

The relative time, in seconds, when the fault occurred. As measured from time 0, which is the last time the Safety Controller was powered up.

Name Length

The number of ASCII characters in the "Name String".

Name String

An ASCII-string describing the source of the fault.

Error Code, Advanced Error Code, Error Index Message

The Error Code and the Advanced Error Code, taken together, form the Safety Controller Fault Code. The format for the Fault Code is Error Code 'dot' Advanced Error Code. For example, a Safety Controller Fault Code of 2.1 is represented by an Error Code of 2 and an Advanced Error Code of 1. The Error Message Index value is the Error Code and the Advanced Error Code together, and includes a leading zero with the Advanced Error Code, if necessary. For example, a Safety Controller Fault Code of 2.1 is represented by an Error Message Index of 201. The Error Message Index value is a convenient way to get the complete Fault Code while only reading a single 16-bit register.

System Information Buffer

Slot 19 can be filled with the optional System Information Buffer Module.

Table 74: Safety Controller System Information Buffer Module (Ident 0x0600) [optional; fixed in Slot 19 when used]

PLC Input Data Name	Input Data Type	PLC Output Data Name	Output Data Type
System Information Buffer	30 words	Not applicable	Not applicable

System Information Buffer	Type	Length (Words)
Seconds Since Boot	UDINT	2
Operating Mode	WORD	1
Length of Config Name	DWORD	2
Config Name	String	8
Config CRC	WORD	2

Seconds Since Boot

A 32-bit integer representation of the number of seconds since powering up the Safety Controller.

Operating Mode

The current operational state of the Safety Controller.

Operating Mode Value	Description
1 (0x01)	Normal Operating Mode (including I/O faults, if present)
2 (0x02)	Configuration Mode
4 (0x04)	System Lockout
65 (0x41)	Waiting for System Reset/Exiting Configuration Mode
129 (0x81)	Entering Configuration Mode

Length of Config Name

The number of ASCII characters in the "Config Name".

Config Name

An ASCII-string describing the source of the fault.

Config CRC

The Cyclic Redundancy Check (CRC) value for the current Safety Controller configuration.

ISD Status Information Module 4 Chain

Slot 20 can be filled with the optional ISD Status Information Module 4 Chain.



Note:

- Not all Safety Controller support ISD.
- Only the XS26-ISD models support more than two chains of ISD devices.

Table 75: ISD Status Information Module 4 Chain (Ident 0x0700) [optional; fixed in Slot 20 when used]

PLC Output Data Name	Output Data Type
Not applicable	Unsigned 16

PLC Input Data Name	Input Data Type
ISD System Status – Chain 1 Device Count	Unsigned 32
ISD System Status – Chain 2 Device Count	Unsigned 32
ISD System Status – Chain 1 Device On/Off Status (see ISD System Status Words on page 206)	Unsigned 32
ISD System Status – Chain 2 Device On/Off Status (see ISD System Status Words on page 206)	Unsigned 32
ISD System Status – Chain 1 Fault Status (see ISD System Status Words on page 206)	Unsigned 32
ISD System Status – Chain 2 Fault Status (see ISD System Status Words on page 206)	Unsigned 32
ISD System Status – Chain 1 Marginal Status (see ISD System Status Words on page 206)	Unsigned 32
ISD System Status – Chain 2 Marginal Status (see ISD System Status Words on page 206)	Unsigned 32
ISD System Status – Chain 1 Alert Status (see ISD System Status Words on page 206)	Unsigned 32
ISD System Status – Chain 2 Alert Status (see ISD System Status Words on page 206)	Unsigned 32
ISD System Status – Chain 1 Reset Status (see ISD System Status Words on page 206)	Unsigned 32
ISD System Status – Chain 2 Reset Status (see ISD System Status Words on page 206)	Unsigned 32
ISD System Status – Chain 1 Actuator Recognized (see ISD System Status Words on page 206)	Unsigned 32
ISD System Status – Chain 2 Actuator Recognized (see ISD System Status Words on page 206)	Unsigned 32
ISD System Status – Chain 1 System Status (see ISD Chain System Status on page 50)	Unsigned 32
ISD System Status – Chain 2 System Status (see ISD Chain System Status on page 50)	Unsigned 32
ISD System Status – Chain 3 Device Count	Unsigned 32
ISD System Status – Chain 4 Device Count	Unsigned 32
ISD System Status – Chain 3 Device On/Off Status (see ISD System Status Words on page 206)	Unsigned 32
ISD System Status – Chain 4 Device On/Off Status (see ISD System Status Words on page 206)	Unsigned 32
ISD System Status – Chain 3 Fault Status (see ISD System Status Words on page 206)	Unsigned 32
ISD System Status – Chain 4 Fault Status (see ISD System Status Words on page 206)	Unsigned 32
ISD System Status – Chain 3 Marginal Status (see ISD System Status Words on page 206)	Unsigned 32
ISD System Status – Chain 4 Marginal Status (see ISD System Status Words on page 206)	Unsigned 32
ISD System Status – Chain 3 Alert Status (see ISD System Status Words on page 206)	Unsigned 32
ISD System Status – Chain 4 Alert Status (see ISD System Status Words on page 206)	Unsigned 32
ISD System Status – Chain 3 Reset Status (see ISD System Status Words on page 206)	Unsigned 32
ISD System Status – Chain 4 Reset Status (see ISD System Status Words on page 206)	Unsigned 32
ISD System Status – Chain 3 Actuator Recognized (see ISD System Status Words on page 206)	Unsigned 32
ISD System Status – Chain 4 Actuator Recognized (see ISD System Status Words on page 206)	Unsigned 32
ISD System Status – Chain 3 System Status (see ISD Chain System Status on page 50)	Unsigned 32
ISD System Status – Chain 4 System Status (see ISD Chain System Status on page 50)	Unsigned 32

ISD Individual Device Information Module

Slot 21 can be filled with the optional ISD Individual Device Information Module.

See also [Request Performance and Status Information about an Individual Device via ISD](#) on page 50 and [ISD Individual Device-Specific Data Detailed Description](#) on page 270.

Table 76: ISD Individual Status Information Module (Ident 0x0800) [optional; fixed in Slot 21 when used]

PLC Input Data Name	Input Data Type	PLC Output Data Name	Output Data Type
ISD Read Request Acknowledge	Unsigned 16	ISD Read Request	Unsigned 16
ISD Chain Requested Acknowledge	Unsigned 16	ISD Chain Requested	Unsigned 16
ISD Device Requested Acknowledge	Unsigned 16	ISD Device Requested	Unsigned 16
ISD Individual Device-Specific Data (18 Bytes) ⁵³	Byte		

ISD Individual Device-Specific Data Detailed Description

The following table describes Slot 21 ⁵⁴.

Table 77: ISD Individual Device-Specific Data Detailed Description

Module Input	Information	Data size
206.0	Safety Input Fault	1 bit
206.1	<i>reserved</i>	1 bit
206.2	Sensor Not Paired	1-bit
206.3	ISD Data Error	1-bit
206.4	Wrong Actuator/Button Status/Input Status	1-bit
206.5	Marginal Range/Button Status/Input Status	1-bit
206.6	Actuator Detected	1-bit
206.7	Output Error	1-bit
207.0	Input 2	1-bit
207.1	Input 1	1-bit
207.2	Local Reset Expected	1-bit
207.3	Operating Voltage Warning	1-bit
207.4	Operating Voltage Error	1-bit
207.5	Output 2	1-bit
207.6	Output 1	1-bit
207.7	Power Cycle Required	1-bit
208.0	Fault Tolerant Outputs	1-bit
208.1	Local Reset Unit	1-bit
208.2	Cascadable	1-bit
208.3	High Coding Level	1-bit
208.7 to 208.4	Teach-ins Remaining	4-bit
209.4 to 209.0	Device ID	5-bit
210.2 to 209.5	Range Warning Count	6-bit
210.7 to 210.3	Output Switch-off Time	5-bit
211	Number of Voltage Errors	8-bit

⁵³ For conversion to Internal Temperature, Actuator Distance, and Supply Voltage, see [ISD: Temperature, Voltage, and Distance Conversion Information](#) on page 296.

⁵⁴ The Slot 21 example assumes that the slot starts at PLC address %I200. Bytes 0–5 are used by the ISD Read Request Acknowledge, the ISD Chain Requested Acknowledge, and the ISD Device Requested Acknowledge. The example also assumes data is in byte format.

Module Input	Information	Data size
212	Internal Temperature ⁵⁵	8-bit
213	Actuator Distance ⁵⁵	8-bit
214	Supply Voltage ⁵⁵	8-bit
215.3 to 215.0	Expected Company Name	4-bit
215.7 to 215.4	Received Company Name	4-bit
217 to 216	Expected Code	16-bit
219 to 218	Received Code	16-bit
221 to 220	Internal Error A	16-bit
223 to 222	Internal Error B	16-bit

ISD Status Information Module 8 Chain

Slot 22 can be filled with the optional ISD Status Information Module 8 Chain.



Note:

- Not all Safety Controllers support ISD.
- Only the XS26-ISD supports more than two chains of ISD devices.

Table 78: ISD Status Information Module 8 Chain (Ident 0×0900) [optional; fixed in Slot 22 when used]

PLC Output Data Name	Output Data Type
Not applicable	Unsigned 16

PLC Input Data Name	Input Data Type
ISD System Status – Chain 1 Device Count	Unsigned 32
ISD System Status – Chain 1 Device On/Off Status (see ISD System Status Words on page 206)	Unsigned 32
ISD System Status – Chain 1 Fault Status (see ISD System Status Words on page 206)	Unsigned 32
ISD System Status – Chain 1 Marginal Status (see ISD System Status Words on page 206)	Unsigned 32
ISD System Status – Chain 1 Alert Status (see ISD System Status Words on page 206)	Unsigned 32
ISD System Status – Chain 1 Reset Status (see ISD System Status Words on page 206)	Unsigned 32
ISD System Status – Chain 1 Actuator Recognized (see ISD System Status Words on page 206)	Unsigned 32
ISD System Status – Chain 1 System Status (see ISD Chain System Status on page 50)	Unsigned 32
ISD System Status – Chain 2 Device Count	Unsigned 32
ISD System Status – Chain 2 Device On/Off Status (see ISD System Status Words on page 206)	Unsigned 32
ISD System Status – Chain 2 Fault Status (see ISD System Status Words on page 206)	Unsigned 32
ISD System Status – Chain 2 Marginal Status (see ISD System Status Words on page 206)	Unsigned 32
ISD System Status – Chain 2 Alert Status (see ISD System Status Words on page 206)	Unsigned 32
ISD System Status – Chain 2 Reset Status (see ISD System Status Words on page 206)	Unsigned 32
ISD System Status – Chain 2 Actuator Recognized (see ISD System Status Words on page 206)	Unsigned 32
ISD System Status – Chain 2 System Status (see ISD Chain System Status on page 50)	Unsigned 32
ISD System Status – Chain 3 Device Count	Unsigned 32
ISD System Status – Chain 3 Device On/Off Status (see ISD System Status Words on page 206)	Unsigned 32
ISD System Status – Chain 3 Fault Status (see ISD System Status Words on page 206)	Unsigned 32

⁵⁵ For conversion to Internal Temperature, Actuator Distance, and Supply Voltage, see [ISD: Temperature, Voltage, and Distance Conversion Information](#) on page 296.

PLC Input Data Name	Input Data Type
ISD System Status – Chain 8 Marginal Status (see ISD System Status Words on page 206)	Unsigned 32
ISD System Status – Chain 8 Alert Status (see ISD System Status Words on page 206)	Unsigned 32
ISD System Status – Chain 8 Reset Status (see ISD System Status Words on page 206)	Unsigned 32
ISD System Status – Chain 8 Actuator Recognized (see ISD System Status Words on page 206)	Unsigned 32
ISD System Status – Chain 8 System Status (see ISD Chain System Status on page 50)	Unsigned 32

ISD Specific Chain Information Module

Slot 23 can be filled with the optional ISD Specific Chain Information Module.

See also [ISD Individual Device Information Module](#) on page 269.

See also [Request Performance and Status Information about an Individual Device via ISD](#) on page 50.



Note: Not all Safety Controllers support ISD.

Table 79: ISD Specific Chain Information Module (Ident 0x0A00) [optional; fixed in Slot 23 when used]

PLC Input Data Name	Input Data Type	PLC Output Data Name	Output Data Type
List of Detected ISD Devices on a Chain	Array of 32 bytes	Not applicable	Unsigned 16

12.7.7 Configuration Instructions

Installing the GSD File

Use these instructions to install the GSD file in the Siemens TIA Portal (v15) software. Use these instructions as a basis for installing the GSD file in another controller (PLC).

1. Download the GSD file from www.bannerengineering.com.
2. Start the Siemens TIA Portal (v15) software.
3. Click **Open existing project**.
4. Select a project and open it.
5. Click **Devices & networks** after the project has been uploaded.

Figure 254. Devices and Networks

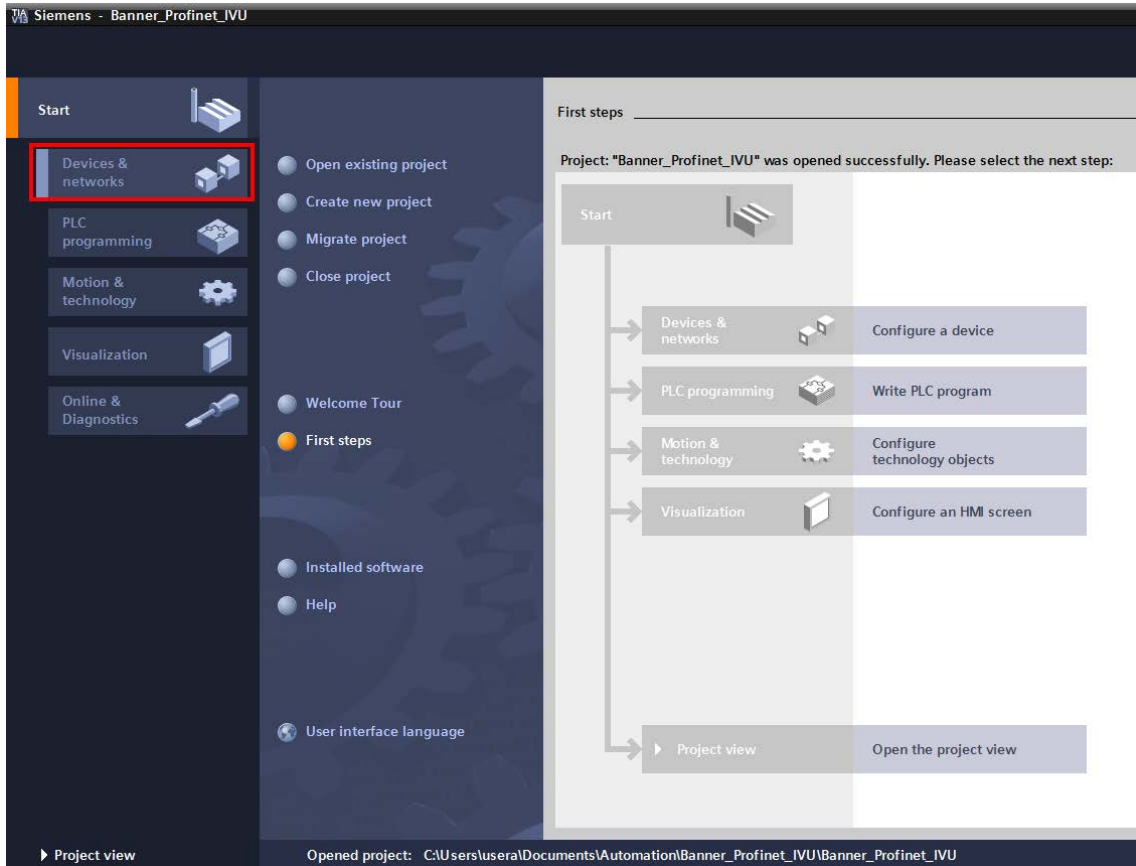

6. Click **Configure networks**.

Figure 255. Configure Networks

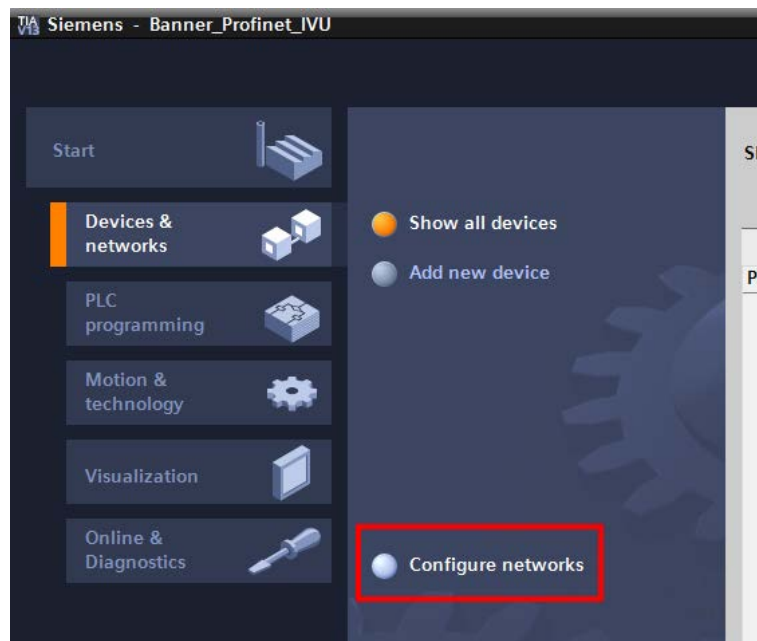

Network view displays.

7. Click **Options** and select **Manage general station description file (GSD)**.

Figure 256. Options—Install the GSD

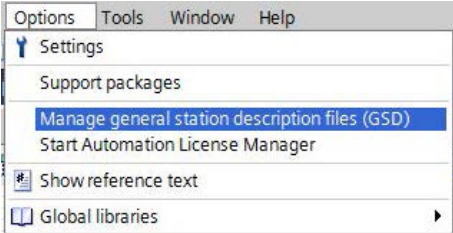

The **Install general station description file** window opens.

- 8. Click the browse button (...) to the right of the **Source path** field.

Figure 257. Manage GSD Files

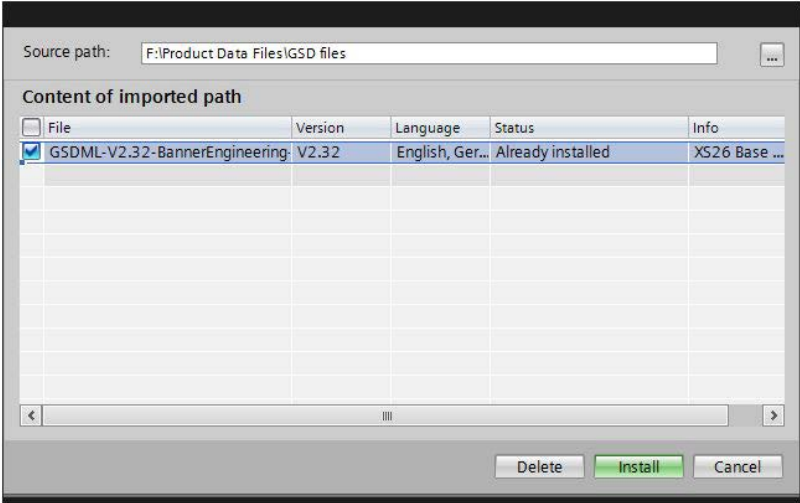

- 9. Navigate to the location the Safety Controller GSD file was downloaded to.
- 10. Select the Safety Controller GSD file.
- 11. Click **Install**.

Figure 258. Hardware Catalog

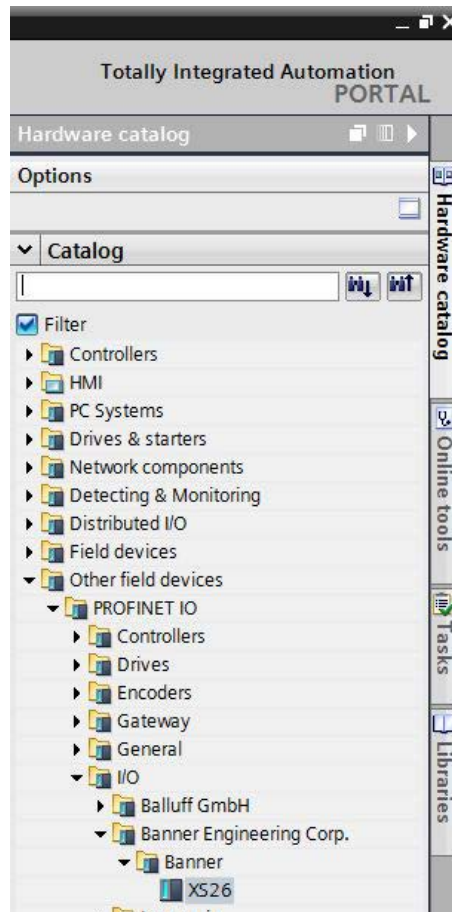

12. Click **Close** when the install finishes.

13. Click **Devices & networks**.

The system installs the Safety Controller GSD file and places it in the **Hardware catalog**. In the above example, the Safety Controller GSD file is located under **Other field devices > PROFINET IO > I/O > Banner Engineering Corp. > Banner**



Note: If the Safety Controller GSD file does not install properly, save the log and contact Banner Engineering.

Adding a Device to a Project

Use these instructions to add a XS/SC26 device to a Siemens TIA Portal (v15) project, and to configure the device. Use these instructions as a basis for adding a XS/SC26 device to another controller (PLC).

1. Start the Siemens TIA Portal (v15) software.
2. Click **Open existing project**.
3. Select a project and open it.
4. Click **Devices & networks** after the project has been uploaded.

Figure 259. Devices and Networks

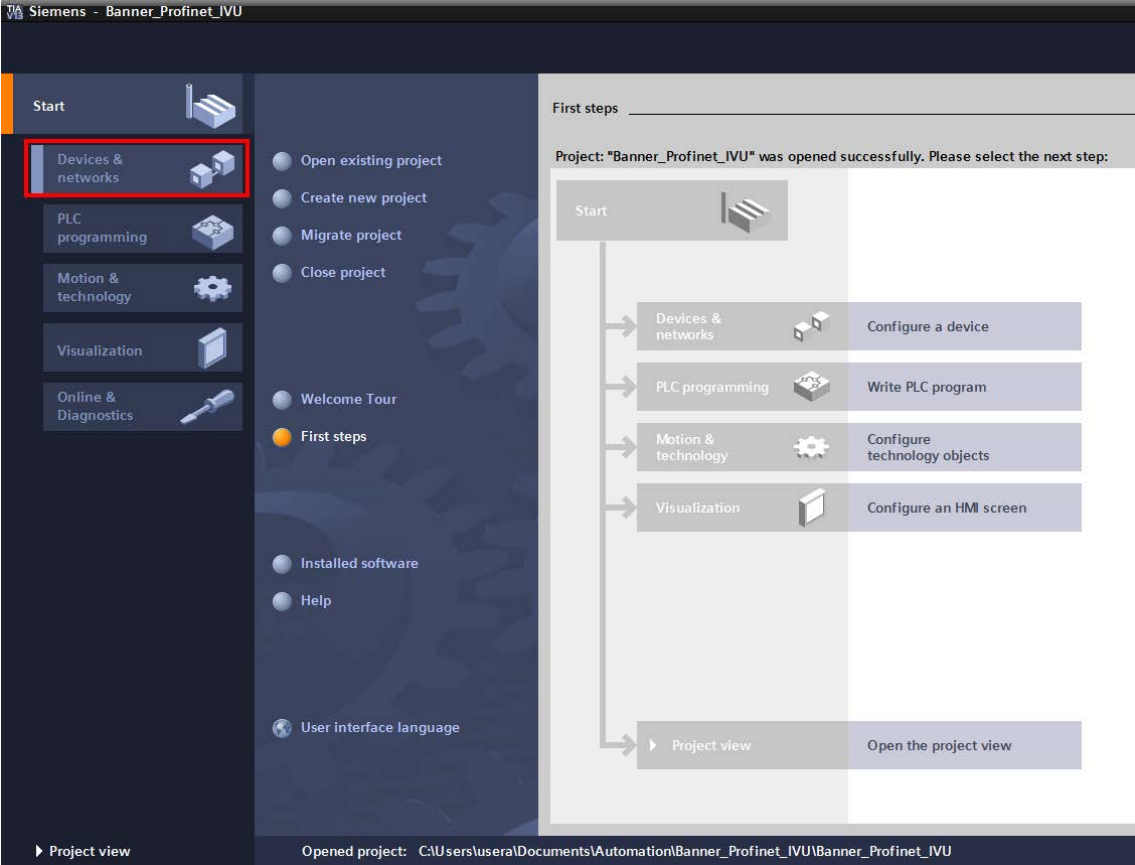

5. Click **Configure networks**.

Figure 260. Configure Networks



Network view displays.



Note: For Step 6 through Step 10, **Network view** must be open.

6. Locate the XS/SC26 in the **Hardware catalog**.

Figure 263. Device Overview Tab

Module	Rack	Slot	I address	Q address	Type
xs26	0	0			XS26
4 Status Bytes, Bits 0..31_1	0	1	2...5		4 Status Bytes, Bits 0..31
4 Status Bytes, Bits 0..31_2	0	2	6...9		4 Status Bytes, Bits 0..31
4 Status Bytes, Bits 0..31_3	0	3	10...13		4 Status Bytes, Bits 0..31
4 Status Bytes, Bits 0..31_4	0	4	14...17		4 Status Bytes, Bits 0..31
4 Status Bytes, Bits 0..31_5	0	5	18...21		4 Status Bytes, Bits 0..31
4 Status Bytes, Bits 0..31_6	0	6	22...25		4 Status Bytes, Bits 0..31
4 Status Bytes, Bits 0..31_7	0	7	26...29		4 Status Bytes, Bits 0..31
4 Status Bytes, Bits 0..31_8	0	8	30...33		4 Status Bytes, Bits 0..31
4 Status Bytes, Bits 0..31_9	0	9	34...37		4 Status Bytes, Bits 0..31
4 Status Bytes, Bits 0..31_10	0	10	38...41		4 Status Bytes, Bits 0..31
4 Status Bytes, Bits 0..31_11	0	11	42...45		4 Status Bytes, Bits 0..31
4 Status Bytes, Bits 0..31_12	0	12	46...49		4 Status Bytes, Bits 0..31
8 Bytes Virtual On/OffIME Data_1	0	13		2...9	8 Bytes Virtual On/OffIME Data
2 Bytes RCD Data_1	0	14		10...11	2 Bytes RCD Data
2 Byte RCD Acutation Code_1	0	15		12...13	2 Byte RCD Acutation Code
RCD Data Feedback Register_1	0	16	50...51		RCD Data Feedback Register
RCD Passcode Feedback Register_1	0	17	52...53		RCD Passcode Feedback Register
	0	18			
	0	19			
	0	20			
	0	21			
	0	22			
	0	23			

Note: The default connection uses slots 1 to 17.

10. Select the desired modules or submodules from the **Hardware catalog** and drag them onto the **Device overview** tab on the **Device view** tab.
The Safety Controller device is configured.

Add Optional Modules to the PROFINET Configuration

Use these instructions to add optional XS26 modules to an existing PROFINET configuration in the Siemens TIA Portal (v15) software.

To establish the PROFINET connection, see [Adding a Device to a Project](#) on page 276.

1. Open a project and click on **Devices & networks** to go to the **Network view**.

Figure 264. Network view

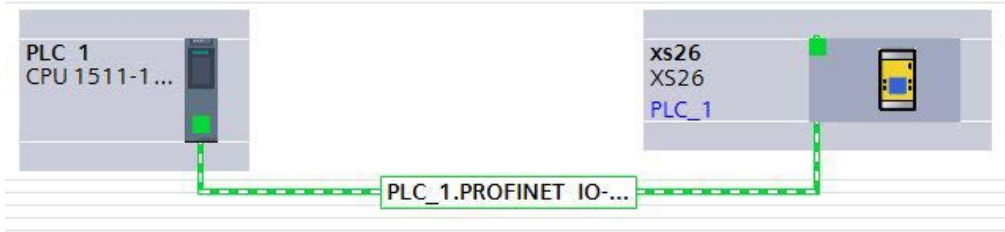

Network view displays.

2. Double click the XS26 icon in the **Network view** window to open the **Device overview** window.
3. Click on the **Hardware catalog** tab along the right side of the TIA Portal software, then click on the **Module** folder.
This is a list of the optional modules available for use in the PROFINET configuration.

Figure 265. Hardware Catalog—Module Folder

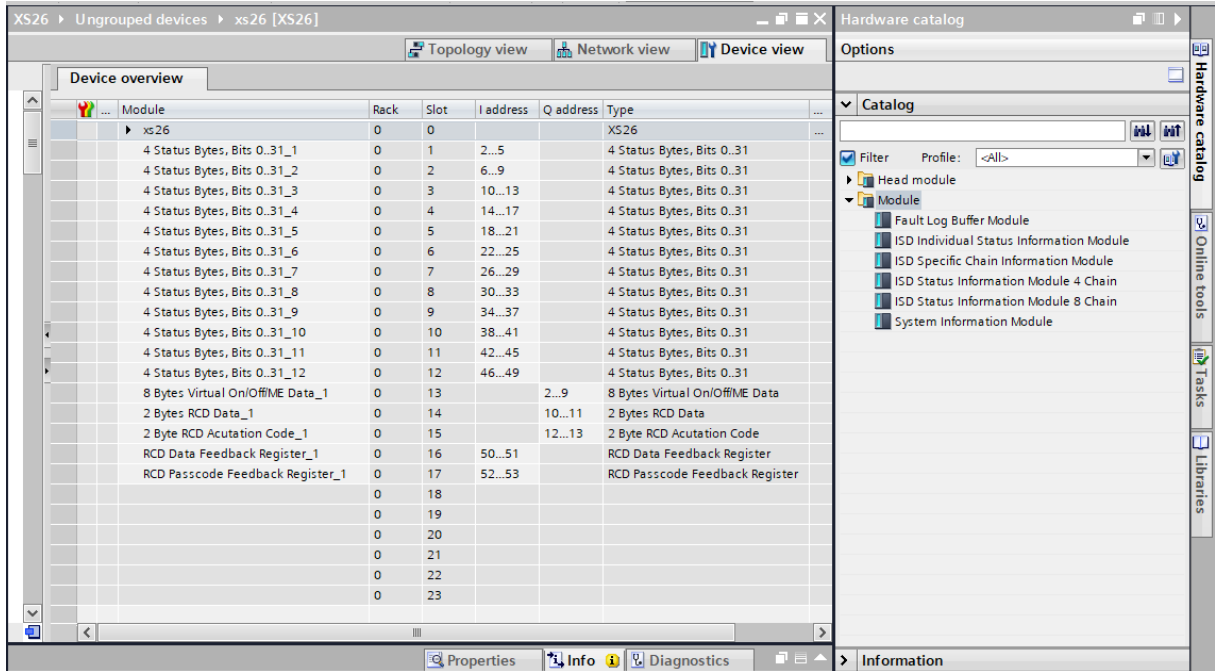

Each optional module is tied to one specific slot in the configuration. For example:

- The optional **Fault Log Buffer Module**, for example, can only be added to slot 18
- The optional **ISD Specific Chain Information Module** can only be added to slot 23
- The optional **System Information Module** can only be added to slot 19

4. Highlight the module in the **Catalog**. Its corresponding slot is outlined in blue.

Figure 266. Device Overview—Module and Corresponding Slot

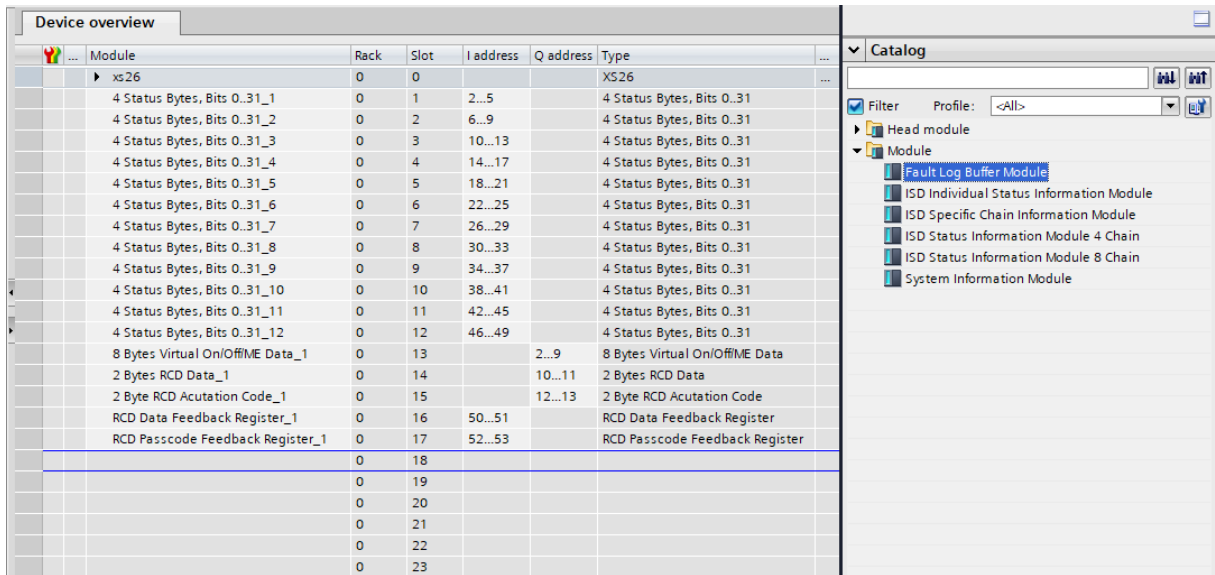

5. Double click on the module in the **Catalog** to add it to the configuration.

Example Configuration

The following is a configuration that makes use of a variety of optional modules. Note that the IO Controller (PLC) has automatically assigned I and Q addresses in the order in which the modules were added to the configuration. These PLC Slot Address Locations (%I and %Q) are required when creating an XML File for PROFINET to label the data.

Figure 267. Example Configuration

Module	Rack	Slot	I address	Q address	Type
xs26	0	0			XS26
1	0	0 X1			xs26
4 Status Bytes, Bits 0..31_1	0	1	2...5		4 Status Bytes, Bits 0..31
4 Status Bytes, Bits 0..31_2	0	2	6...9		4 Status Bytes, Bits 0..31
4 Status Bytes, Bits 0..31_3	0	3	10...13		4 Status Bytes, Bits 0..31
4 Status Bytes, Bits 0..31_4	0	4	14...17		4 Status Bytes, Bits 0..31
4 Status Bytes, Bits 0..31_5	0	5	18...21		4 Status Bytes, Bits 0..31
4 Status Bytes, Bits 0..31_6	0	6	22...25		4 Status Bytes, Bits 0..31
4 Status Bytes, Bits 0..31_7	0	7	26...29		4 Status Bytes, Bits 0..31
4 Status Bytes, Bits 0..31_8	0	8	30...33		4 Status Bytes, Bits 0..31
4 Status Bytes, Bits 0..31_9	0	9	34...37		4 Status Bytes, Bits 0..31
4 Status Bytes, Bits 0..31_10	0	10	38...41		4 Status Bytes, Bits 0..31
4 Status Bytes, Bits 0..31_11	0	11	42...45		4 Status Bytes, Bits 0..31
4 Status Bytes, Bits 0..31_12	0	12	46...49		4 Status Bytes, Bits 0..31
8 Bytes Virtual On/Off/IME Data_1	0	13		2...9	8 Bytes Virtual On/Off/IME Data
2 Bytes RCD Data_1	0	14		10...11	2 Bytes RCD Data
2 Byte RCD Acutation Code_1	0	15		12...13	2 Byte RCD Acutation Code
RCD Data Feedback Register_1	0	16	50..51		RCD Data Feedback Register
RCD Passcode Feedback Register_1	0	17	52...53		RCD Passcode Feedback Register
	0	18			
System Information Module_1	0	19	54...83		System Information Module
	0	20			
ISD Individual Status Information Module_1	0	21			ISD Individual Status Information Module
ISD Device Information Request	0	21 IS...		14...19	ISD Device Information Request
ISD Device Information Response	0	21 IS...	372...395		ISD Device Information Response
ISD Status Information Module 8 Chain_1	0	22	84...339		ISD Status Information Module 8 Chain
ISD Specific Chain Information Module_1	0	23	340...371		ISD Specific Chain Information Module

Changing the Device IP Address

Use these instructions to change the IP address of the Safety Controller device, using the Siemens TIA Portal (v15) software. Use these instructions as a basis if you are using another controller (PLC).

1. Start the Siemens TIA Portal (v15) software.
2. Click **Open existing project**.
3. Select a project and open it.
4. Click **Devices & networks** after the project has been uploaded to go to **Network view**.

Figure 268. Network View

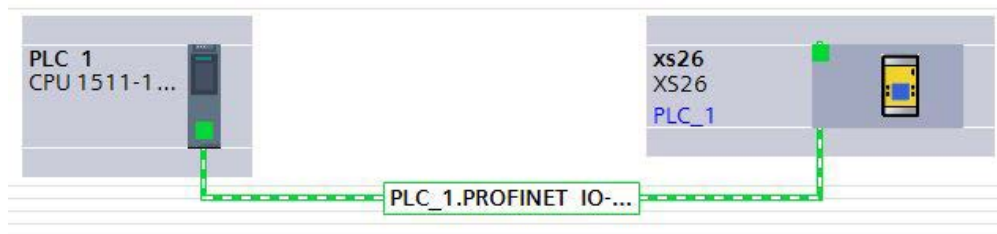

Network View displays.

5. Double-click on the Safety Controller icon to open the **Device view**.
6. Click on the Safety Controller icon in the graphic area of the **Device view** to open the **Module properties** window. The module can now be configured.
7. Click **Properties**.
8. Click **General**.
9. Select **PROFINET interface > Ethernet addresses**.

Figure 269. Ethernet Addresses

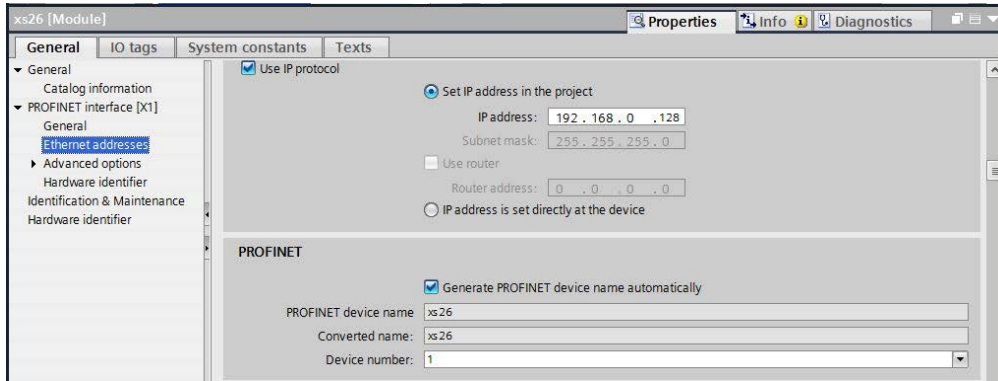

10. Select **Set IP address in the project**.

Figure 270. Set IP Address

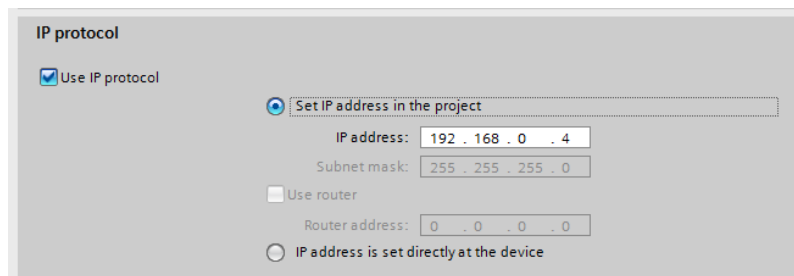

The project sets the IP address of the device.

11. Enter the IP address.

12. Right-click on the device icon and select **Online & diagnostics**.

Figure 271. Select Online & Diagnostics

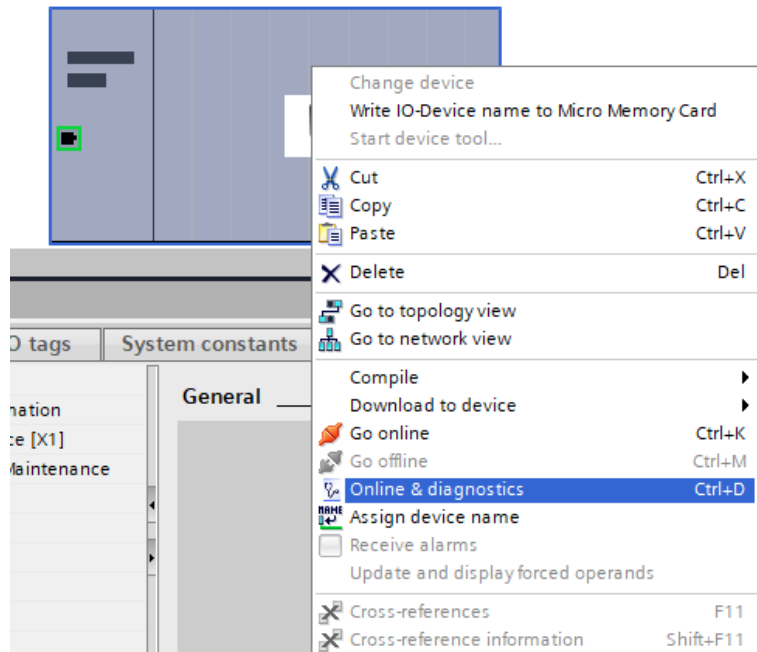
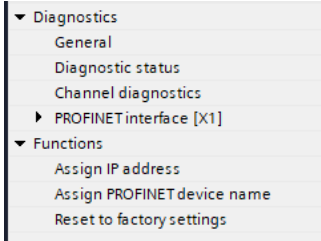
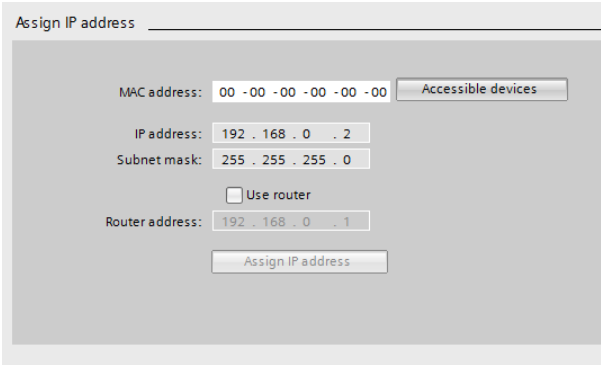

Figure 272. Online & Diagnostics



- The **Online & diagnostics** window displays.
13. Select **Assign IP address** under **Functions**.
 14. Click **Accessible devices**.

Figure 273. Assign IP Address—Accessible Devices



- The **Select device** window searches the network for available devices.
15. Determine the device to be adjusted via the MAC address and select it.
 16. Click **Apply**.

Figure 274. Select the Device and Apply Changes

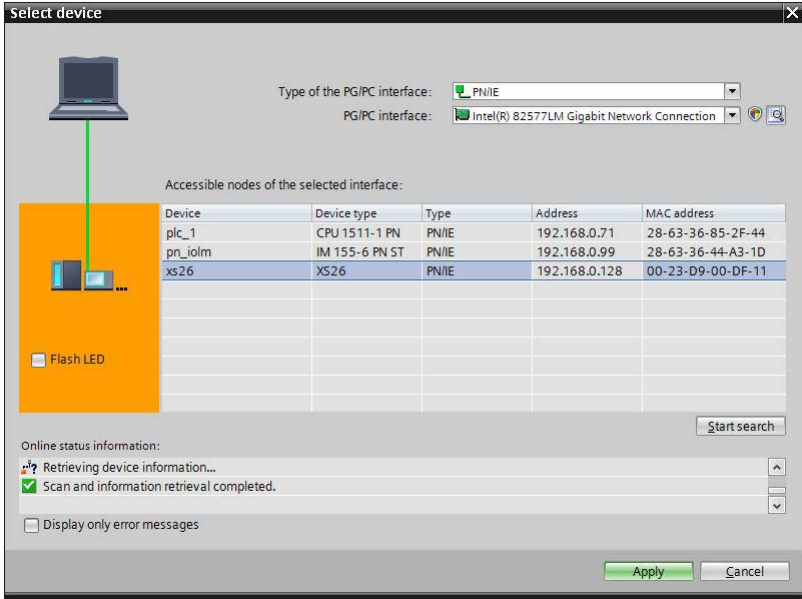

- The IP address for the device is updated.
17. Click **Assign IP address** to complete the step.
- This step is completed for every device.



Note: PROFINET devices commonly lack an IP address on startup (IP address = all zeros). However, Safety Controller devices require an IP address to connect to Banner Safety Controller to set the device configuration.

By default, each Banner Engineering device shipped from the factory is assigned the IP address 192.168.0.128. The default address can be changed using the Banner Safety Controller software.

Immediately after the PROFINET protocol has been enabled in the Banner Engineering device, but before the PLC discovers and connects to the Banner Engineering device, the Banner Engineering device will retain its IP address. After the PLC discovers and connects to the Banner Engineering device, the behavior of the IP address depends on how the PLC was configured to assign the Banner Engineering device IP address. Two configuration options are available.

Figure 275. Siemens TIA Portal (v15): IP Protocol Options

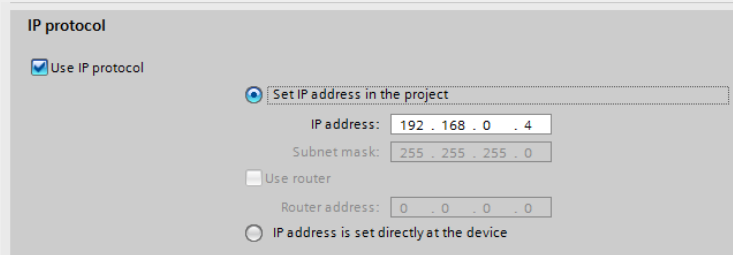

- The IP address is set in the project: If the PLC is told to assign the Banner Engineering device IP address (for example, using the **Set IP address in the project** option in Siemens TIA Portal), the Banner Engineering device receives the specified address, but only after the program has been loaded into the PLC and is running.

If the Banner Engineering device is restarted after it was discovered and configured by the PLC, the Banner Engineering device has an IP address of 0.0.0.0 until the PLC discovers it and assigns it the specified address again.

When the Banner Engineering device has no IP address assigned, it is still possible to assign an IP address to the Banner Engineering device using Banner Safety Controller. However, if this address is different than what is specified in the PLC, the Banner Engineering device reverts to the address specified in the PLC when the PLC becomes active again.

- The IP address is set at the device: If the PLC is told that the Banner Engineering device IP address is configured at the device (for example, using the **IP address is set directly at the device** option in Siemens TIA Portal), the Banner Engineering device always retains the IP address that was assigned to through Banner Safety Controller.

These configuration options conform to the PROFINET standard.

Changing the Device Name

Use these instructions to change the name of the Safety Controller device, using the Siemens TIA Portal (v15) software. Use these instructions as a basis if you are using another controller (PLC).

1. Open a project and click on **Devices & networks** to go to the **Network view**.

Figure 276. Network View



Network view displays.

2. Right-click on the Safety Controller icon and select **Assign device name**.

Figure 277. Ethernet Addresses

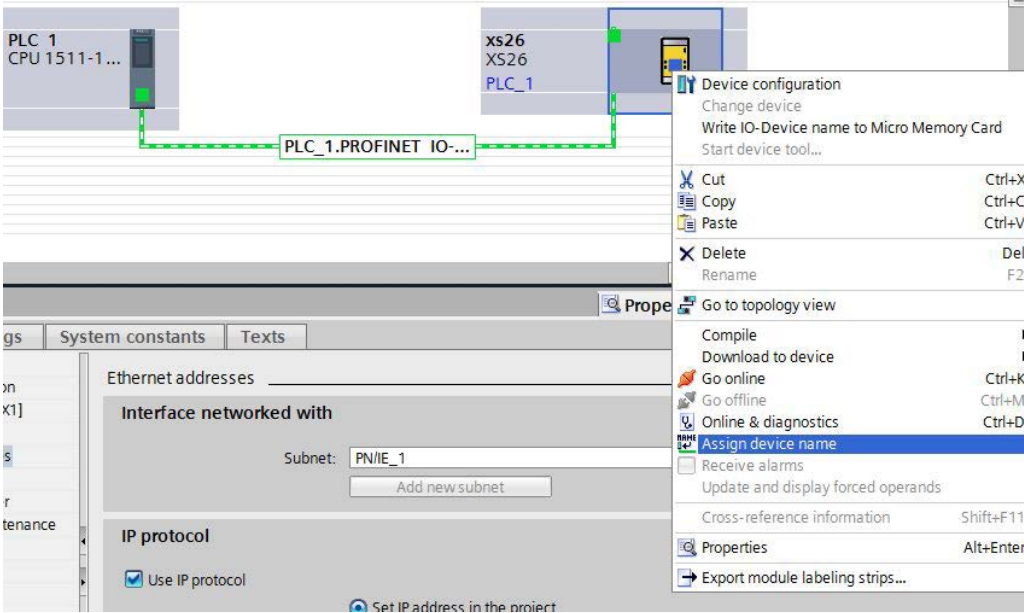

The Assign PROFINET device name window displays, and the software searches for devices of the same type.

Figure 278. Ethernet Addresses

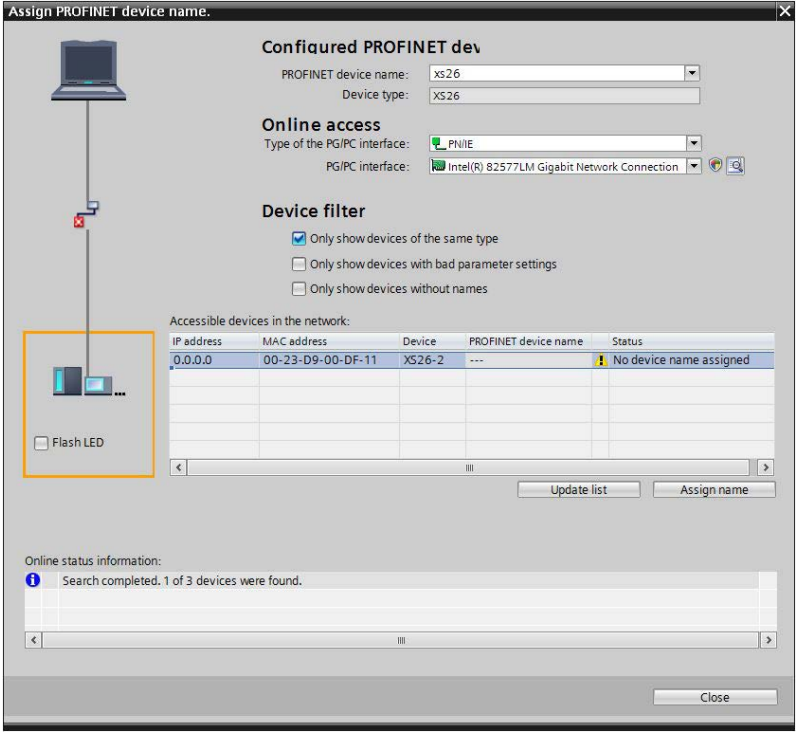

3. Enter the desired name in the **PROFINET device name** field.

 **Note:** Each name can be used only once.

4. Click **Assign name**.
The device now has a PROFINET name.

Figure 279. Ethernet Addresses

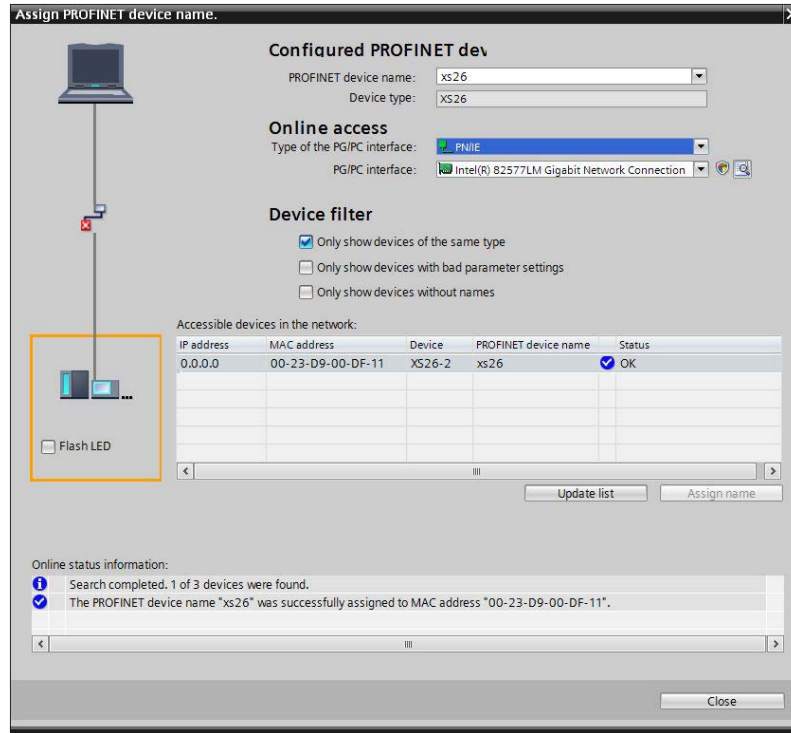

12.8 EtherCAT[®]

EtherCAT[®] 57 is a data communication protocol for industrial automation processes. EtherCAT IO defines how controllers (IO controllers) and peripheral devices (IO devices) exchange data in real time.

The Banner Safety Controller supports EtherCAT IO. The EtherCAT protocol follows the IEC 61158 standard; the data transmission medium is copper wire.



Note: In this document, outputs from the Safety Controller device are referred to as "inputs" to the controller (PLC). Outputs from the controller (PLC) are referred to as "inputs" to the Safety Controller device.

12.8.1 EtherCAT[®] and the Safety Controllers

This section covers instructions for XS/SC26 Safety Controllers with the FID 6 designation on the product label.

The Safety Controller must have the EtherCAT communications gateway, XSeCAT, installed.

EtherCAT real time data is transmitted and received via Process Data Objects (PDO).



Note: The ESI file is available for download at www.bannerengineering.com/safetycontroller.

12.8.2 EtherCAT[®] Slave Information (ESI) File

The EtherCAT Slave Information (ESI) file contains module information, such as:

- Configuration data
- Data information (pass count, inspection status, etc.)
- Diagnostics

⁵⁷ EtherCAT[®] is a registered trademark and patented technology, licensed by Beckhoff Automation GmbH, Germany.

12.8.3 EtherCAT[®] IO Data Model

The EtherCAT IO data model is based on the typical, expandable field device that has a backplane with slots.

Each slot is either a Tx-PDO (Transmit Process Data Object) or a Rx-PDO (Received Process Data Object). The Tx-PDO or Rx-PDO is broken up into data structures. The majority of the XS/SC26 data is broken up in PDOs with 4 bytes of data. The ISD, RCD, Fault Log, and System Information PDOs have custom structures.

- A PDO is designated as either a Tx (Transmit) or a Rx (Received)
- A Transmit PDO is used to send data to the controller (PLC)
- A Received PDO is used to receive data from the controller (PLC)

12.8.4 Configuring the Safety Controller for EtherCAT[®] IO Connection

1. Connect the Safety Controller to the PC via the SC-USB2 USB cable.
2. Open the Banner Safety Controller Software, and click the **Industrial Ethernet** tab.
3. Check that the EtherCAT Communication Gateway has been added in the **Equipment** tab for the Project file. The **EtherCAT** tab should automatically display, because the EtherCAT Communication Gateway is in **Equipment** tab.
4. Click  to add information to the EtherCAT Process Data Object (PDO). **Auto Configure** can assist in this task.
5. Provide the appropriate password to change the configuration and network settings for the Safety Controller.
6. Make sure the Safety Controller has a valid and confirmed configuration file.



Note: If a Virtual Reset or Cancel Delay is used, an Actuation Code must be created in **Network Settings**. Then the code must be sent to the Safety Controller using **Send** in **Network Settings**.



Note: ClickSet IP is not available for EtherCAT.

12.8.5 Create a PLCOpenXML for EtherCAT[®] for TwinCAT[®] 3.0

Two items must be known:

- The name of the project in TwinCAT[®] 62
- The name of the Safety Controller in the system

This information is available in the PLC software. The following figure is an example from Beckhoff TwinCAT 3.0 software.

Figure 280. Solution Explorer

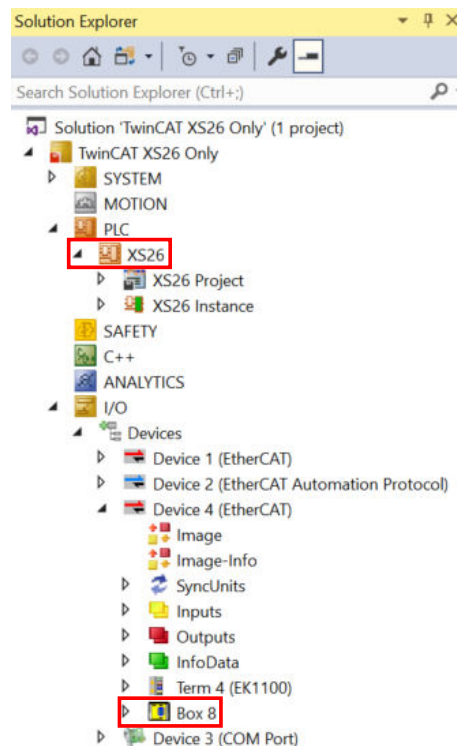

⁶² TwinCAT[®] is a registered trademark of and licensed by Beckhoff Automation GmbH, Germany.

1. In the Banner Safety Controller software, on the **Industrial Ethernet** tab, make sure **EtherCAT** is selected from the list at the left.
2. Click **Export**.
The **Export to XML** window opens.

Figure 281. *Export to XML—No ISD Chains*

Figure 282. *Export to XML—with ISD Chains*

3. Enter the information in the window.
 - a) In the **Project Name** field, enter the name of the project in the PLC software. See item 1 in [Figure 281](#) on page 288. In this example it is `XS26`.
 - b) In the **Controller Name** field, enter the name of the Safety Controller in the PLC Software. See item 2 in [Figure 281](#) on page 288. In this example it is `Box 8`.
4. Click **Export**.
5. Save the PLCopenXML file to the desired location.

The PLCopenXML file is ready to be directly imported into the Beckhoff TwinCAT software or the file can be opened with any software that can read an .xml file.

12.8.6 Description of Process Data Objects

Table 80: *PDO Assignment*

In this table, the I/O direction is from the point of view of the PLC.

PDO	Name	IO	Size (Bytes)
1A00	User-Defined VS TxPDO [1] 0×1A00	In	4
1A01	User-Defined VS TxPDO [2] 0×1A01	In	4
1A02	Faults VS TxPDO [1] 0×1A02	In	4
1A03	Faults VS TxPDO [2] 0×1A03	In	4
1A04	Inputs VS TxPDO[1] 0×1A04	In	4
1A05	Inputs VS TxPDO[2] 0×1A05	In	4
1A06	Inputs VS TxPDO[3] 0×1A06	In	4
1A07	Inputs VS TxPDO[4] 0×1A07	In	4

PDO	Name	IO	Size (Bytes)
1A08	Inputs VS TxPDO[5] 0×1A08	In	4
1A09	Outputs VS TxPDO[1] 0×1A09	In	4
1A0A	Outputs VS TxPDO[2] 0×1A0A	In	4
1A0B	Outputs VS TxPDO[3] 0×1A0B	In	4
1A0C	Reset, Cancel Delay Feedback TxPDO 0×1A0C	In	4
1A10	ISD Device Information Response 0×1A10 ⁶⁴	In	56
1A20	System Status of ISD Chain 1 TxPDO 0×1A20 ⁶⁴	In	32
1A3A	ECAT Module Status TxPDO 0×1A3A	In	4
1600	On/Off, Mute Enable VI RxPDO [1] 0×1600	Out	4
1601	On/Off, Mute Enable VI RxPDO [2] 0×1601	Out	4
1602	Reset, Cancel Delay Control RxPDO 0×1610	Out	4
1610	ISD Device Information Request RxPDO 0×1610 ⁶⁴	Out	6

User-Defined Status Bits

PDO 1 and PDO 2 are filled with User-Defined Status Bit Process Data Objects (PDO). These PDO include 64 bits worth of virtual status output information of any type.

Table 81: User-Defined VS TxPDO [1] 0×1A00

PLC Input Data Name	Input Data Type
User-Defined VS TxPDO [1] 0×1A00 Byte 0	BYTE
User-Defined VS TxPDO [1] 0×1A00 Byte 1	BYTE
User-Defined VS TxPDO [1] 0×1A00 Byte 2	BYTE
User-Defined VS TxPDO [1] 0×1A00 Byte 3	BYTE

Table 82: User-Defined VS TxPDO [2] 0×1A01

PLC Input Data Name	Input Data Type
User-Defined VS TxPDO [2] 0×1A01 Byte 0	BYTE
User-Defined VS TxPDO [2] 0×1A01 Byte 1	BYTE
User-Defined VS TxPDO [2] 0×1A01 Byte 2	BYTE
User-Defined VS TxPDO [2] 0×1A01 Byte 3	BYTE

Fault Bits

PDO 3 and PDO 4 are filled with 64 bits of fault type virtual status output information from the Safety Controller.

Table 83: Faults VS TxPDO [1] 0×1A02

PLC Input Data Name	Input Data Type
Faults VS TxPDO [1] 0×1A02 Byte 0	BYTE
Faults VS TxPDO [1] 0×1A02 Byte 1	BYTE
Faults VS TxPDO [1] 0×1A02 Byte 2	BYTE
Faults VS TxPDO [1] 0×1A02 Byte 3	BYTE

⁶⁴ This PDO assignment is off by default.

Table 84: Faults VS TxPDO [2] 0×1A03

PLC Input Data Name	Input Data Type
Faults VS TxPDO [2] 0×1A03 Byte 0	BYTE
Faults VS TxPDO [2] 0×1A03 Byte 1	BYTE
Faults VS TxPDO [2] 0×1A03 Byte 2	BYTE
Faults VS TxPDO [2] 0×1A03 Byte 3	BYTE

Input Status Bits

PDO 5 through PDO 9 are reserved for 160 bits of Safety Controller input information. An expandable Safety Controller might have up to 154 inputs, if all of the eight possible expansion cards are used as 16-channel inputs (in addition to the 26 inputs built into the Base Controller).

Table 85: Inputs VS TxPDO [1] 0×1A04

PLC Input Data Name	Input Data Type
Inputs VS TxPDO [1] 0×1A04 Byte 0	BYTE
Inputs VS TxPDO [1] 0×1A04 Byte 1	BYTE
Inputs VS TxPDO [1] 0×1A04 Byte 2	BYTE
Inputs VS TxPDO [1] 0×1A04 Byte 3	BYTE

Table 86: Inputs VS TxPDO [2] 0×1A05

PLC Input Data Name	Input Data Type
Inputs VS TxPDO [2] 0×1A05 Byte 0	BYTE
Inputs VS TxPDO [2] 0×1A05 Byte 1	BYTE
Inputs VS TxPDO [2] 0×1A05 Byte 2	BYTE
Inputs VS TxPDO [2] 0×1A05 Byte 3	BYTE

Table 87: Inputs VS TxPDO [3] 0×1A06

PLC Input Data Name	Input Data Type
Inputs VS TxPDO [3] 0×1A06 Byte 0	BYTE
Inputs VS TxPDO [3] 0×1A06 Byte 1	BYTE
Inputs VS TxPDO [3] 0×1A06 Byte 2	BYTE
Inputs VS TxPDO [3] 0×1A06 Byte 3	BYTE

Table 88: Inputs VS TxPDO [4] 0×1A07

PLC Input Data Name	Input Data Type
Inputs VS TxPDO [4] 0×1A07 Byte 0	BYTE
Inputs VS TxPDO [4] 0×1A07 Byte 1	BYTE
Inputs VS TxPDO [4] 0×1A07 Byte 2	BYTE
Inputs VS TxPDO [4] 0×1A07 Byte 3	BYTE

Table 89: Inputs VS TxPDO [5] 0×1A08

PLC Input Data Name	Input Data Type
Inputs VS TxPDO [5] 0×1A08 Byte 0	BYTE
Inputs VS TxPDO [5] 0×1A08 Byte 1	BYTE
Inputs VS TxPDO [5] 0×1A08 Byte 2	BYTE

PLC Input Data Name	Input Data Type
Inputs VS TxPDO [5] 0×1A08 Byte 3	BYTE

Output Status Bits

PDO 10 through PDO 12 are reserved for 96 Safety Controller output type virtual status output bits.

Table 90: Outputs VS TxPDO [1] 0×1A09

PLC Input Data Name	Input Data Type
Outputs VS TxPDO [1] 0×1A09 Byte 0	BYTE
Outputs VS TxPDO [1] 0×1A09 Byte 1	BYTE
Outputs VS TxPDO [1] 0×1A09 Byte 2	BYTE
Outputs VS TxPDO [1] 0×1A09 Byte 3	BYTE

Table 91: Outputs VS TxPDO [2] 0×1A0A

PLC Input Data Name	Input Data Type
Outputs VS TxPDO [2] 0×1A0A Byte 0	BYTE
Outputs VS TxPDO [2] 0×1A0A Byte 1	BYTE
Outputs VS TxPDO [2] 0×1A0A Byte 2	BYTE
Outputs VS TxPDO [2] 0×1A0A Byte 3	BYTE

Table 92: Outputs VS TxPDO [3] 0×1A0B

PLC Input Data Name	Input Data Type
Outputs VS TxPDO [3] 0×1A0B Byte 0	BYTE
Outputs VS TxPDO [3] 0×1A0B Byte 1	BYTE
Outputs VS TxPDO [3] 0×1A0B Byte 2	BYTE
Outputs VS TxPDO [3] 0×1A0B Byte 3	BYTE

Virtual Reset, Cancel Delay (RCD) Feedback

PDO 13 contains the RCD Actuation Code Feedback along with 16 virtual non-safety inputs. They are used in virtual reset, cancel delay sequence.

See [Virtual Manual Reset and Cancel Delay \(RCD\) Sequence](#) on page 61.

Table 93: Virtual Reset, Cancel Delay

PLC Input Data Name	Input Data Type
RCD Actuation Code Feedback	UINT
Reset, Cancel Delay Feedback TxPDO [1] 0×1A0C Byte 0	BYTE
Reset, Cancel Delay Feedback TxPDO [1] 0×1A0C Byte 1	BYTE

ISD Device Information Response

PDO 14 contains the response data for communication to an individual ISD Device.

See also [Request Performance and Status Information about an Individual Device via ISD](#) on page 50 and [ISD Individual Device-Specific Data Detailed Description](#) on page 202.

Table 94: ISD Device Information Response

PLC Input Data Name	Input Data Type
ISD Request Acknowledgement	UINT

PLC Input Data Name	Input Data Type
ISD Chain Acknowledgement	UINT
ISD Device Acknowledgement	UINT
ISD Device Information ⁶⁶	ARRAY[0..17] of BYTE
Detected Device [0–15] in One Chain	ARRAY[0..15] of BYTE
Detected Device [16–31] in One Chain	ARRAY[0..15] of BYTE

ISD Individual Device Information-Specific Data Detailed Description

Gives the data format for PLC Input Data Name: ISD Device Information.

See [ISD Device Information Response](#) on page 291.

Table 95: ISD Individual Device Data

Information	Byte.Word	Data Size
Safety Input Fault	0.0	1-bit
<i>reserved</i>	0.1	1-bit
Sensor Not Paired	0.2	1-bit
ISD Data Error	0.3	1-bit
Wrong Actuator/Button Status/Input Status	0.4	1-bit
Marginal Range/Button Status/Input Status	0.5	1-bit
Actuator Detected	0.6	1-bit
Output Error	0.7	1-bit
Input 2	1.0	1-bit
Input 1	1.1	1-bit
Local Reset Expected	1.2	1-bit
Operating Voltage Warning	1.3	1-bit
Operating Voltage Error	1.4	1-bit
Output 2	1.5	1-bit
Output 1	1.6	1-bit
Power Cycle Required	1.7	1-bit
Fault Tolerant Outputs	2.0	1-bit
Local Reset Unit	2.1	1-bit
Cascadable	2.2	1-bit
High Coding Level	2.3	1-bit
Teach-ins Remaining	2.7 to 2.4	4-bit
Device ID	3.4 to 3.0	5-bit
Range Warning Count	4.2 to 3.5	6-bit
Output Switch-off Time	4.7 to 4.3	5-bit
Number of Voltage Errors	5	8-bit
Internal Temperature	6	8-bit
Actuator Distance	7	8-bit
Supply Voltage	8	8-bit

⁶⁶ For the data format, see [ISD Individual Device Information-Specific Data Detailed Description](#) on page 292.

Information	Byte.Word	Data Size
Expected Company Name	9.3 to 9.0	4-bit
Received Company Name	9.7 to 9.4	4-bit
Expected Code	11 to 10	16-bit
Received Code	13 to 12	16-bit
Internal Error A	15 to 14	16-bit
Internal Error B	17 to 16	16-bit

System Status of ISD Chain – 8 Chains

PDO 15 to PDO 22 cover the data specific to an individual ISD Chain. Each chain has its own data.

Table 96: Individual ISD Chain Status

PLC Input Data Name	Input Data Type
Number of Inputs in Chain #	UDINT
Chain Status of Chain # ⁶⁷	ARRAY[0..27] of BYTE

Chain Status of Chain #-Specific Data Detailed Description

Gives the data format for PLC Input Data Name: Chain Status of Chain #.

See [System Status of ISD Chain – 8 Chains](#) on page 293.

Table 97: ISD Individual Chain Data

Information	Data Size
Chain # Device Count	32-bit
Chain # Device On/Off (see ISD System Status Words on page 206)	32-bit
Chain # Fault Status (see ISD System Status Words on page 206)	32-bit
Chain # Marginal Status (see ISD System Status Words on page 206)	32-bit
Chain # Alert Status (see ISD System Status Words on page 206)	32-bit
Chain # Reset Status (see ISD System Status Words on page 206)	32-bit
Chain # Actuator Recognized (see ISD System Status Words on page 206)	32-bit
Chain # System Status (see ISD Chain System Status on page 50)	32-bit

EtherCAT Module Status

PLC Input Data Name	Input Data Type
ECAT Module Status	UINT
Operating Mode	UINT

Virtual On, OFF, Mute Enable Bits

PDO 25 is filled with 64 virtual non-safety inputs, to be used as virtual on/off inputs (to the Safety Controller) or virtual mute enable inputs (to the Safety Controller).

Table 98: Virtual On, OFF, Mute Enable Bits 0×1600

PLC Output Data Name	Output Data Type
On/Off, Mute Enable VI RxPDO [1] 0×1600 Byte 0	BYTE
On/Off, Mute Enable VI RxPDO [1] 0×1600 Byte 1	BYTE

⁶⁷ For the data format, see [Chain Status of Chain #-Specific Data Detailed Description](#) on page 293.

PLC Output Data Name	Output Data Type
On/Off, Mute Enable VI RxPDO [1] 0×1600 Byte 2	BYTE
On/Off, Mute Enable VI RxPDO [1] 0×1600 Byte 3	BYTE

Table 99: Virtual On, OFF, Mute Enable Bits 0×1601

PLC Output Data Name	Output Data Type
On/Off, Mute Enable VI RxPDO [2] 0×1601 Byte 0	BYTE
On/Off, Mute Enable VI RxPDO [2] 0×1601 Byte 1	BYTE
On/Off, Mute Enable VI RxPDO [2] 0×1601 Byte 2	BYTE
On/Off, Mute Enable VI RxPDO [2] 0×1601 Byte 3	BYTE

Virtual Reset, Cancel Delay (RCD) Control

PDO 26 contains the RCD Actuation Code, an important code word used in the virtual reset, cancel delay sequence.

See [Virtual Manual Reset and Cancel Delay \(RCD\) Sequence](#) on page 61. This PDO also contains sixteen virtual non-safety inputs, to be used in the virtual reset, cancel delay sequence.

Table 100: RCD Control

PLC Output Data Name	Output Data Type
RCD Actuation Code	UDINT
Reset, Cancel Dealy Control RxPDO [1] 0×1602 Byte 0	BYTE
Reset, Cancel Dealy Control RxPDO [1] 0×1602 Byte 1	BYTE

ISD Individual Device Information Request

PDO 27 contains the response data for communication to an individual ISD Device.

See also [Request Performance and Status Information about an Individual Device via ISD](#) on page 50 and [ISD Individual Device-Specific Data Detailed Description](#) on page 202.

Table 101: ISD Individual Device Information Request

PLC Output Data Name	Output Data Type
ISD Read Request	UINT
ISD Chain Requested	UINT
ISD Device Requested	UINT

12.8.7 Configuration Instructions

Installing the ESI File

Use these instructions to install the ESI file in the Beckhoff TwinCAT 3 software.

1. Download the ESI file from www.bannerengineering.com.
2. Navigate to the `TwinCAT/3.1/Config/IO/EtherCAT` folder.
3. Move the ESI file to this folder.
The ESI will be available in TwinCAT the next time the program is started.

Adding the Safety Controller to a Project

Use these instructions to add a XS/SC26 device to a TwinCAT project.

1. Start the TwinCAT 3 software.
2. Open a project.
3. Expand the I/O selection.
4. Right-click on the device that the Banner Safety Controller will be a part of.

5. Select the **Add New Item** option.
"Banner Engineering Corporation" will be listed. Optionally, use the Search and enter `XS26` to quickly select the ESI.
6. Select **XS26 EtherCAT Module**.
7. Change the **Name** as necessary for the system.
8. Click **OK** to add the Safety Controller into the system.

12.8.8 EtherCAT[®] PDO Modification

The EtherCAT PDO can be modified. By default, only a specific set of data is activated.

It is possible to turn ON PDO that are currently OFF, while also turning OFF PDO that are currently ON. Adjusting the PDO allows for sending and receiving only the data needed for the application.

The smaller the PDO, the easier it is to fit into the allocated packet size for EtherCAT.

Use the following instructions to turn ON and OFF PDO as required.

Access the PDO Menu

1. In TwinCAT Solution Explorer, double-click on the Banner Safety Controller in the I/O tree.
A window opens. The **General** tab is active by default.
2. Click on the **Process Data** tab.
This is the tab that allows for turning ON and OFF PDO.
3. Make note of the Outputs and Inputs in the **Sync Manager** pane.

Figure 283. Output and Inputs in Sync Manager

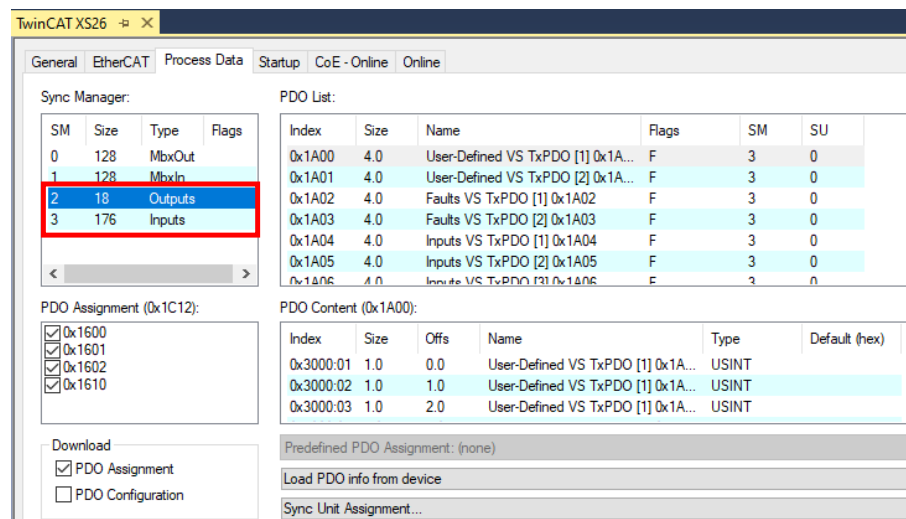

Turn Off a PDO

This example procedure turns OFF an output PDO.

1. From the **Sync Manager** pane in TwinCAT, select either **Outputs** or **Inputs**.
2. Examine the **PDO Assignment** pane for Outputs.
3. Clear the checkbox for the item you want to turn OFF.

This example turns OFF PDO 0x1610 (ISD Device Information Request).

Figure 284. PDO Assignment—All Outputs Selected

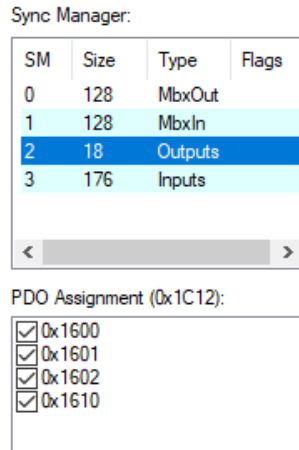
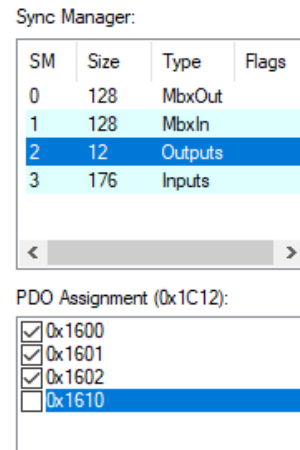

Figure 285. PDO Assignment—0x1610 Cleared



4. Repeat this process as needed for all items that need to be turned OFF.

Turn On a PDO

This example procedure turns on an input PDO.

1. From the **Sync Manager** pane in TwinCAT, select either **Outputs** or **Inputs**.
2. Examine the **PDO Assignment** pane for Inputs.
3. Select the checkbox for the item or items you want to turn ON.

This example turns ON PDO 0x1A20 and 0x1A21 (ISD Status Chain 1 and ISD Status Chain 2).

Figure 286. PDO Assignment—All Inputs Cleared

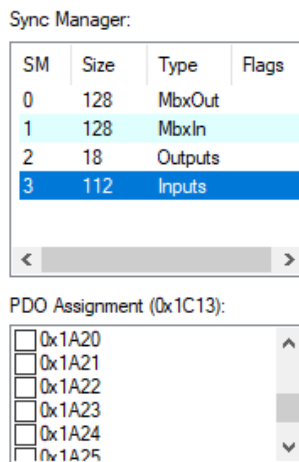
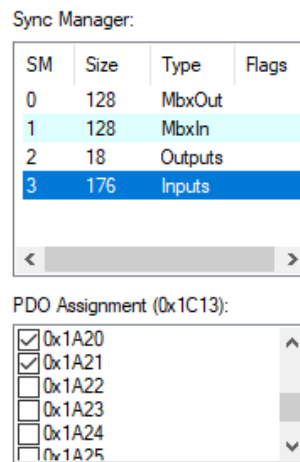

Figure 287. PDO Assignment—Two Inputs Selected



12.9 ISD: Additional Information

12.9.1 ISD: Temperature, Voltage, and Distance Conversion Information

Download an AOI from www.bannerengineering.com to insert into the PLC program to perform the conversions from the obtained values to the real values.

ISD: Supply Voltage

To obtain the actual voltage reading from the Analog to digital conversion (ADC) value sent to the PLC, multiple the ADC value by 0.1835.

$$\text{Supply Voltage} = \text{ADC Value} \times 0.1835$$

ISD: Internal Temperature

First, shift the Analog to digital conversion (ADC) value left by 2 bits. Then, convert the binary reading into a number. If the number matches an ADC value in the following table, read the temperature. If the number is between the readings in the table, use the following formula to obtain the actual temperature.

$$\text{Internal Temperature} = ((A-L) / (H-L)) \times 5 + T$$

- A**
the ADC Value obtained from the controller
- L**
the ADC value on the lookup table less than or equal to A
- H**
the ADC value on the lookup table greater than A
- T**
the temperature associated with the L value

Table 102: Temperature

ADC Reading	Temperature (°C)
41	-40
54	-35
69	-30
88	-25
110	-20
136	-15
165	-10
199	-5
237	0
278	5
321	10
367	15
414	20
461	25
508	30
554	35
598	40
640	45
679	50
715	55
748	60
778	65
804	70
829	75
850	80
869	85
886	90
901	95
914	100
926	105
936	110

ISD: Actuator Distance

Convert the binary reading into a number. If the number matches an Analog to digital conversion (ADC) value in the following table, read the distance. If the number is between the readings in the table, use the following formula to obtain the actual distance.

$$\text{Actuator Distance} = ((A-L) / (H-L)) + D$$

- A**
the ADC Value obtained from the controller
- L**
the ADC value on the lookup table less than or equal to A
- H**
the ADC value on the lookup table greater than A
- D**
the distance associated with the L value

Table 103: Distance

ADC Reading	Distance (mm)
<62	<7
62	7
65	8
77	9
110	10
133	11
148	12
158	13
163	14
169	15
172	16
176	17
180	18
>180	>18

13 System Checkout

13.1 Schedule of Required Checkouts

Verifying the configuration and proper functioning of the Safety Controller includes checking each safety and non-safety input device, along with each output device. As the inputs are individually switched from the Run state to the Stop state, the safety outputs must be validated that they turn On and Off as expected.

Banner Engineering highly recommends performing the checkouts as described. However, a qualified person (or team) should evaluate these generic recommendations considering their specific application and determine the appropriate frequency of checkouts. This will generally be determined by a risk assessment, such as the one contained in ANSI B11.0. The result of the risk assessment will drive the frequency and content of the periodic checkout procedures and must be followed.



WARNING:

- **Do not use the system until the checkouts are verified**
- Attempts to use the guarded/controlled machine before these checks are verified could result in serious injury or death.
- If all these checks cannot be verified, do not attempt to use the safety system that includes the Banner Engineering device and the guarded/controlled machine until the defect or problem has been corrected.

A comprehensive test must be used to verify the operation of the Safety Controller and the functionality of the intended configuration. [Initial Setup, Commissioning, and Periodic Checkout Procedures](#) on page 300 is intended to assist in developing a customized (configuration-specific) checklist for each application. This customized checklist must be made available to maintenance personnel for commissioning and periodic checkouts. A similar, simplified daily checkout checklist should be made for the operator (or Designated Person ⁷⁰). It is highly recommended to have copies of the wiring and logic diagrams and the configuration summary available to assist in the checkout procedures.



WARNING:

- **Perform Periodic Checkouts**
- Failure to perform these checks could create a dangerous situation that could result in serious injury or death.
- The appropriate personnel must perform the commissioning, periodic, and daily safety system checks at the suggested times to ensure that the safety system is operating as intended.

Commissioning Checkout: A Qualified Person ⁷⁰ must perform a safety system commissioning procedure before the safeguarded machine application is placed into service and after each Safety Controller configuration is created or modified.

Periodic (Semi-Annual) Checkout: A Qualified Person ⁷⁰ must also perform a safety system re-commissioning semi-annually (every 6 months) or at periodic intervals based on the appropriate local or national regulations.

Daily Operational Checks: A Designated Person ⁷⁰ must also check the effectiveness of the risk reduction measures, per the device manufacturers' recommendation, each day that the safeguarded machine is in service.



WARNING:

- **Clear the guarded area before applying power or resetting the system**
- Failure to clear the guarded area before applying power could result in serious injury or death.
- Verify that the guarded area is clear of personnel and any unwanted materials before applying power to the guarded machine or before resetting the system.

13.2 Commissioning Checkout Procedure

Before proceeding, verify that:

- All solid-state and relay output terminals of the complete Safety Controller system are not connected to the machine. Disconnecting all of the Safety Controller's safety output plug-on terminals is recommended
- Power has been removed from the machine, and no power is available to the machine controls or actuators

Permanent connections are made at a later point.

⁷⁰ See [Glossary](#) on page 347 for definitions.

13.2.1 Verifying System Operation

The commissioning checkout procedure must be performed by a Qualified Person ⁷¹. It must be performed only after configuring the Safety Controller and after properly installing and configuring the safety systems and safeguarding devices connected to its inputs (see [Safety Input Device Options](#) on page 36 and the appropriate standards).

The commissioning checkout procedure is performed on two occasions:

1. When the Safety Controller is first installed, to ensure proper installation.
2. Whenever any maintenance or modification is performed on the System or on the machine being guarded by the System, to ensure continued proper Safety Controller function (see [Schedule of Required Checkouts](#) on page 299).

For the initial part of the commissioning checkout, the Safety Controller and associated safety systems must be checked without power being available to the guarded machine. Final interface connections to the guarded machine cannot take place until these systems have been checked out.

Verify that:

- **The Safety Output leads are isolated**—not shorted together, and not shorted to power or ground
- If used, the external device monitoring (EDM) connections have been connected to +24 V DC via the normally closed (NC) monitoring contacts of the device(s) connected to the safety outputs, as described in [External Device Monitoring \(EDM\)](#) on page 70 and the wiring diagrams
- The proper Safety Controller configuration file for your application has been installed into the Safety Controller
- All connections have been made according to the appropriate sections and comply with NEC and local wiring codes

This procedure allows the Safety Controller and the associated safety systems to be checked out, by themselves, before permanent connections are made to the guarded machine.

13.2.2 Initial Setup, Commissioning, and Periodic Checkout Procedures

There are two ways to verify that the Safety Outputs are changing state at the appropriate times in the initial configuration check out phase (open the **Configuration Summary** tab in the Software to view the Startup test and Power-up configuration settings):

- Monitor the LEDs associated with the inputs and outputs. If the input LED is green, the input is high (or 24 V). If the input LED is red, the input is low (or 0 V). Similarly, if the RO1 or RO2 output contacts are closed, the corresponding LED is green. If the contacts are open, the LED is red.
- Start the **Live Mode** in the Software (the Safety Controller must be powered up and plugged in to the PC via the SC-USB2 cable).

Startup Configuration

Outputs associated with Two-Hand Control, Bypass, Press Control, or Enabling Device functions do not turn on at power-up. After power-up, switch these devices to the Stop state and back to the Run state for their associated outputs to turn ON.

For the Press Control Function follow the process discussed in [Press Control](#) on page 153.

If configured for Normal Power-Up

If latch function is not used: verify that Safety Outputs turn ON after power-up.

If either input devices or outputs use the latch function: verify that Safety Outputs do not turn ON after the power-up until the specific manual latch reset operations are performed.

If configured for Automatic Power-Up

Verify that all Safety Outputs turn ON within approximately 7 seconds (outputs with ON-Delay enabled may take longer to turn ON).

If configured for Manual Power-Up

Verify that all Safety Outputs remain OFF after power up.

Wait at least 10 seconds after power-up and perform the Manual Power-Up reset.

Verify that the Safety Outputs turn ON (outputs with ON-Delay enabled may take longer to turn ON).

⁷¹ See [Glossary](#) on page 347 for definitions.

**CAUTION: Verifying Input and Output Function**

The Qualified Person is responsible to cycle the input devices (Run state and Stop state) to verify that the Safety Outputs turn ON and OFF to perform the intended safeguarding functions under normal operating conditions and foreseeable fault conditions. Carefully evaluate and test each Safety Controller configuration to make sure that the loss of power to any safeguarding input device, the Safety Controller, or the inverted input signal from a safeguarding input device, do not cause an unintended Safety Output ON condition, mute condition, or bypass condition.



Note: If an Input or Output indicator is flashing red, see [Troubleshooting](#) on page 330.

Safety Input Device Operation (E-stop, Rope Pull, Optical Sensor, Safety Mat, Protective Stop, Gate Switch, ISD Device Chain)

1. While the associated Safety Outputs are ON, actuate each safety input device, one at a time (including each device in a ISD chain or cascade series).
2. Verify that each associated Safety Output turns OFF with the proper OFF-Delay, where applicable.
3. With the safety device in the Run state:
 - **If a safety input device is configured with a Latch Reset function:**
 1. Verify that the Safety Output remains OFF.
 2. Perform a latch reset to turn the outputs ON.
 3. Verify that each associated Safety Output turns ON.
 - **If no Latch Reset functions are used:** Verify that the Safety Output turns ON



Important: Always test the safeguarding devices according to the recommendations of the device manufacturer.

In the sequence of steps below, if a particular function or device is not part of the application, skip that step and proceed to the next checklist item or to the final commissioning step.

Two-Hand Control Function without Muting

1. Make sure the Two-Hand Control actuators are in the Stop state.
2. Make sure that all other inputs associated with Two-Hand Control function are in the Run state and activate the Two-Hand Control actuators to turn the associated Safety Output On.
3. Verify that the associated Safety Output remains Off unless both actuators are activated within 0.5 seconds of each other.
4. Verify that Safety Output turns Off and remains Off when any single hand is removed and replaced (while maintaining the other actuator in the Run state).
5. Verify that switching a safety input (non-Two-Hand Control actuator) to the Stop state causes the associated Safety Output to turn Off or stay Off.
6. If more than one set of Two-Hand Control actuators are used, the additional actuators need to be activated before the Safety Output turns On. Verify that the Safety Output turns Off and remains Off when any single hand is removed and replaced (while maintaining the other actuators in the Run state).

Two-Hand Control Function with Muting

1. Follow the verification steps in Two-Hand Control function above.
2. Activate the Two-Hand Control actuators then activate the Mute Sensor Pair 1 (MSP1) sensors.
3. With the MSP1 sensors active, remove your hands from the Two-Hand Control and verify that the Safety Output stays On.
4. Verify that the Safety Output turns Off when either:
 - MSP1 sensors are switched to the stop state
 - Mute time limit expires
5. For multiple Two-Hand Control actuators with at least one set of non-mutable actuators: verify that while in an active mute cycle, removing one or both hands from each non-muted actuators causes the Safety Outputs to turn Off.

Bidirectional (Two-Way) Muting Function (Also valid for Zone Control Mute Functions)

1. With the muted safeguard in the Run state, activate the Mute Enable input (if used) and then activate each mute sensor, in sequential order, within 3 seconds.
2. Generate a stop command from the muted safeguarding device:
 - a) Verify that the associated Safety Outputs remain On.
 - b) If a mute time limit has been configured, verify that the associated Safety Outputs turn Off when the mute timer expires.
3. Repeat above steps for each Muting Sensor Pair (MSP).
4. Verify proper operation of each muted safeguarding device.
5. While in the mute cycle, one at a time, generate a stop command from any non-muted safeguarding devices and verify that the associated Safety Outputs turn Off.
6. Verify the mute process in the opposite direction, repeating the process above, activating the mute sensors in the reverse order.

Unidirectional (One Way) Muting Function

1. With the mute sensors not activated, the muted safeguarding devices in the Run state, and the Safety Outputs On:
 - a) Activate Muting Sensor Pair 1 (MSP1).
 - b) Change the muted safeguarding device to the Stop state.
 - c) Activate Muting Sensor Pair 2 (MSP2).
 - d) Deactivate MSP1.
2. Verify the associated Safety Output remains On throughout the process.
3. Repeat the test in the *wrong direction* (MSP2, then the safeguarding device, then MSP1).
4. Verify that when the safeguard changes to the Stop state the output turns Off.

If a mute time limit has been configured

Verify that the associated Safety Outputs turn Off when the mute timer expires.

Mute Function with Power-Up Operation (not applicable for Two-Hand Control)

1. Turn the Safety Controller power off.
2. Activate the Mute Enable input, if used.
3. Activate an appropriate Muting Sensor Pair for starting a mute cycle.
4. Make sure that all mutable safeguarding devices are in the Run state.
5. Apply power to the Safety Controller.
6. Verify that the Safety Output turns ON and that a mute cycle begins.
7. Repeat this test with the mutable safeguard device in the Stop state.
8. Verify that the Safety Output stays OFF.

Mute Function with Mute-Dependent Override

1. Make sure mute sensors are not activated and mute safeguarding devices are in the Run state.
2. Verify that the Safety Outputs are On.
3. Switch the safeguarding device to the Stop state.
4. Verify that the Safety Output turns Off.
5. Activate one of the mute sensors.
6. Verify the optional mute lamp is flashing.
7. Start the mute dependent override by activating the Bypass Switch.
8. Verify that the Safety Output turns On.
9. Verify that the Safety Output turns Off under any of the following conditions:
 - Bypass (Override) Time limit expires
 - Mute sensors are deactivated
 - The Bypass device is deactivated

Mute Function with Bypass

1. Verify that each safety input, that can be both muted and bypassed, is in the Stop state.
2. Verify that when the Bypass Switch is in the Run state:
 - a) The associated Safety Outputs turn On.
 - b) The associated Safety Outputs turn Off when the bypass timer expires.
3. Change the Bypass Switch to the Run state and verify that the associated Safety Outputs turn On.
4. One at a time, switch the associated non-bypassed input devices to their Stop state and verify that associated Safety Outputs turn Off while the Bypass Switch is in the Run state.

Figure 288. Mute Function with Bypass

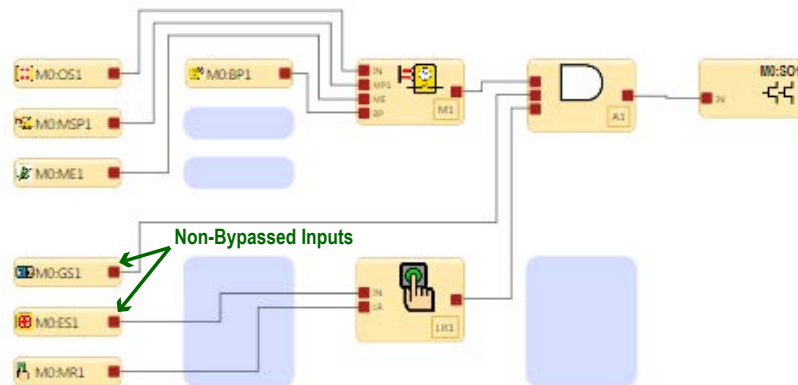

Bypass Function

1. Verify that the associated Safety Outputs are OFF when the safety inputs to be bypassed are in the Stop state.
2. Verify that when the Bypass Switch is in the Run state:
 - a) The associated Safety Outputs turn ON.
 - b) The associated Safety Outputs turn OFF when the bypass timer expires.
3. Change the Bypass Switch to the Run state and verify that the associated Safety Outputs turn ON.
4. One at a time, switch the non-bypassed input devices to the Stop state and verify that the associated Safety Outputs turn OFF while the Bypass Switch is in the Run state.

Safety Output OFF-Delay Function

1. With any one of the controlling inputs in the Stop state and the delayed Safety Output in an OFF-Delay state, verify that the Safety Output turns OFF after the time delay is over.
2. With any one of the controlling inputs in the Stop state and the OFF-Delay timer is active, switch the input to the Run state and verify that the Safety Output is ON and remains ON.

Safety Output OFF-Delay Function—Cancel Delay Input

With the associated inputs in the Stop state and the delayed Safety Output in an OFF-Delay state, activate the Cancel Delay input and verify that the Safety Output turns OFF immediately.

Safety Output OFF-Delay Function—Controlling Inputs

1. With any one of the controlling inputs in the Stop state and the delayed Safety Output is in an OFF-Delay state, switch the input to the Run state.
2. Verify that the Safety Output is ON and remains ON.

Safety Output OFF-Delay Function and Latch Reset

1. Make sure the associated input devices are in the Run state so that the delayed Safety Output is ON.
2. Start the OFF-Delay time by switching an input device to the Stop state.
3. Switch the input device to the Run state again during the OFF-Delay time and push the Reset button.
4. Verify that the delayed output turns OFF at the end of the delay and remains OFF (a latch reset signal during the delay time is ignored).

Enabling Device Function without Secondary Jog Output

Figure 289. Device Function without Secondary Jog Output

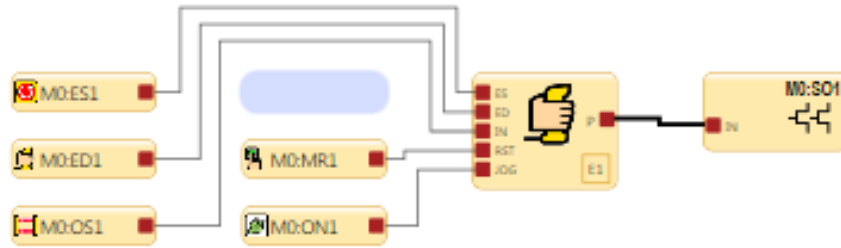

1. With the associated inputs in the Run state and the Enabling Device in the Stop state, verify that the Safety Output is On.
2. With the Enabling Device still in the Run state and the associated Safety Output On, verify that the Safety Output turns Off when the Enabling Device timer expires.
3. Return the Enabling Device to the Stop state and then back to the Run state, and verify that the Safety Outputs turns On.
4. Switch the Enabling Device to the Stop state, and verify that the associated Safety Outputs turn Off.
5. Switch each E-stop and Rope Pull device associated with the Enabling Device function to the Stop state, and verify, one at a time, that the associated Safety Outputs are On and in the Enable mode.
6. With the Enabling Device in the Stop state, perform a reset.
7. Verify that control authority is now based on associated input devices of the Enabling device function:
 - a) If one or more input devices are in the Stop state, verify that the output is Off.
 - b) If all of the input devices are in the Run state, verify that the output is On.

Enabling Device Function—With Jog feature on the Secondary Output

Figure 290. Device Function—With Jog feature on the Secondary Output

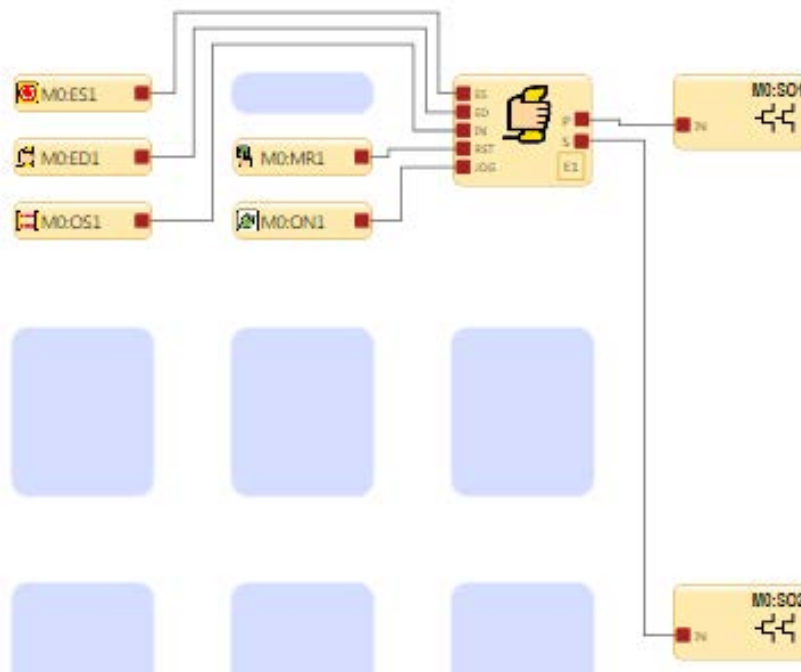

1. With the Enabling Device and the Jog button in the Run state in control of the primary Safety Output, verify that the output turns Off when either the Enabling Device or the Jog button is switched to the Stop state.
2. With the Enabling Device in control of the primary Safety Output and the Jog button in control of the secondary output verify that the primary Output turns:
 - a) ON when the Enabling Device is in the Run state.
 - b) OFF when the Enabling Device is in the Stop state and the Jog button is in the Run state.

3. Verify that the output turns On only when the Enabling Device is in the Run state while the Jog button is in the Run state.
4. Verify that the secondary Output turns:
 - a) ON when the Enabling Device and the Jog button are in the Run state.
 - b) OFF when the either the Enabling Device or the Jog button are in the Stop state.

Press Control Function Block with Single Actuator Control Configured

1. Make sure the Non-Mutable Safety input, Mutable Safety Stop input (if configured), and the TOS are ON.
2. Perform a reset cycle.
3. Momentarily turn ON the GO input. Verify the down motion starts.
4. Use a test piece to block the Mutable Safety Stop input. Verify the down motion stops.
5. Clear the Mutable Safety Stop input and perform a reset cycle.
6. Momentarily turn ON the GO input. Verify the ram moves up to the TOS position and stops.
7. Momentarily turn ON the GO input. Verify the ram moves down.
8. When the ram reaches the BOS point and starts its upward motion, block the Mutable Safety Stop input with the test piece. Verify that the ram continues to move up to the TOS position.

Press Control Function Block with the Manual Upstroke Setting Configured

1. Make sure the Non-Mutable Safety input, Mutable Safety input, and TOS are ON.
2. Perform a reset cycle, turn on PIP (if used), and then engage the GO input. Verify the Down output turns ON.
3. Disengage the GO input. Verify the Down output turns OFF.
4. Engage the GO input. The Down output should turn back ON.
5. Use a test piece to block the Mutable Safety Stop input. Verify the down motion stops.
6. Clear the Mutable Safety Stop input and perform a reset cycle.
7. Engage the GO input. Verify the ram moves up to the TOS position and stops.
8. Engage the GO input. After the RAM reaches the BOS point, verify the Down output turns OFF and the Up output turns ON.
9. With the test piece, block the Mutable Safety Stop input. Verify the up motion stops.
10. Release the GO input.
11. Clear the Mutable Safety Stop input.
12. Perform a reset cycle.
13. Engage the GO input to drive the ram back to the TOS position.

Press Control Mode Function Block Checks

If the Dual Pressure setting is selected, verify all outputs are working correctly. The high-pressure output should only turn on in Run mode.

1. Make sure the Non-Mutable Safety input, Mutable Safety input, and TOS are ON (but all Mode inputs are OFF).
2. Perform a reset cycle, turn on PIP (if used), and then engage the GO input. Verify no output turns ON.
3. Turn off the GO input.
4. Select the RUN state, perform a reset cycle, then engage the GO input. The Down output should turn ON. (Run a complete cycle then stop, including cycling the PIP input.)
5. Turn off the Run input and turn on the Inch Down input.
6. Perform a reset cycle and then engage the GO input. Verify the Down output cycles on and off (and verify the ram speed is within inch specifications).
7. At the BOS point of the process, turn off the Inch Down input and turn on the Inch Up input.
8. Perform a reset cycle and then engage the GO input. Verify the Up output cycles on and off (and verify the ram speed is within inch specifications).

Press Control SQS (or SQS & PCMS) Checks

If the Dual Pressure setting is selected, verify the high-pressure output only turns ON when the ram is moving down from SQS to BOS.

See [Press Control Inputs Function Block](#) on page 155 for specific GO, SQS and Ft Switch configurations and behaviors.

1. Make sure the Non-Mutable Safety input, Mutable Safety input, and TOS are ON.
2. Perform a reset cycle, turn on PIP (if used), and then engage the GO input. Verify the Down output turns ON.

3. Verify that the ram stops at the SQS sensor(s) (or SQS & PCMS sensors).
4. Release (turn off) the GO input. Verify that the gap of the tools is less than 6 mm (finger-safe). Verify that the Mutable Safety Stop input is now muted.
5. Engage the Ft Switch input. Verify that the ram moves from the SQS point to the BOS point and stops.
6. Release the Ft Switch input.
7. Engage the GO input. Verify the RAM returns to the TOS point and stops.
8. Release the GO input.

14 Status and Operating Information

Operate the XS/SC26 Safety Controller using either the onboard interface or Software to monitor ongoing status.

Operate the SC10-2 Safety Controller using the Software to monitor ongoing status.

14.1 XS/SC26 LED Status

LED	Status	Meaning
All	OFF	Initialization Mode
	Sequence: Green ON for 0.5 s Red ON for 0.5 s OFF for 0.5 s minimum	Power applied
Power/Fault	OFF	Power OFF
	Green: Solid	Run mode
	Green: Flashing	Configuration Mode OR Manual Power-Up mode
	Red: Flashing	Non-operating Lockout condition
USB (FID 2 or earlier Base Controller)	OFF	No link to the PC established
	Green: Solid	Link to the PC established
	Green: Flashing for 5 s, then OFF	SC-XM2/3 configuration match
	Red: Flashing for 5 s, then OFF	SC-XM2/3 configuration mismatch
USB (FID 3 or later Base Controller)	OFF	No link established and configured Safety Controller
	Green: Solid	USB cable connected to a configured Safety Controller
	Green: Flashing	No link established and factory default Safety Controller OR USB cable connected and factory default Safety Controller
	Green: Flashing for 4 s, then Green ON	Configured new SC-XM2/3 ⁷² (locked or unlocked) plugged into a factory default Safety Controller
	Green: Flashing for 5 s, then OFF	Configured and unlocked new SC-XM2/3 ⁷² plugged into a configured Safety Controller with a matching configuration, matching passwords, and matching or mismatched network settings OR Old SC-XM2/3 ⁷³ is inserted into FID 3 or later controller (configured or factory default) and has a matching configuration
	Green: Flashing for 5 s, then Red flashing	Configured and locked new SC-XM2/3 ⁷² plugged into a configured Safety Controller with a matching configuration and matching passwords but mismatched network settings
	Red: Flashing	Configured new SC-XM2/3 ⁷² (locked or unlocked) plugged into a configured Safety Controller with a mismatched configuration, a mismatched password, or a blank SC-XM2/3 plugged in OR Blank SC-XM2/3 plugged into a factory default Safety Controller or a configured Safety Controller
	Red: Flashing for 5 s, then OFF	Old SC-XM2/3 ⁷³ is inserted into FID 3 or later controller (configured or factory default) and has a mismatched configuration
Inputs	Green: Solid	No input faults

⁷² "New SC-XM2/3": an SC-XM2/3 that contains information that was created using the Banner Safety Controller Software Version 4.2 or later, or that was created from an FID 3 or later Safety Controller.

⁷³ "Old SC-XM2/3": an SC-XM2/3 that contains information that was created using the Banner Safety Controller Software Version 4.1 or earlier, or that was created from an FID 2 or earlier Safety Controller.

LED	Status	Meaning
	Red: Flashing	One or more inputs is in the Lockout condition
SO1, SO2	OFF	Output not configured
	Green: Solid	Safety Output ON
	Red: Solid	Safety Output OFF
	Red: Flashing	Safety Output fault detected or EDM fault detected or AVM fault detected

LED Status for Split Outputs	Meaning
Green: Solid	Both outputs are ON
Red: Solid	SOxa and/or SOxb is OFF
Red: Flashing	SOxa and/or SOxb fault detected

Ethernet Diagnostic LEDs		
Amber LED	Green LED	Description
ON	Varies with traffic	Link established/normal operation
OFF	OFF	Hardware failure

Amber LED and Green LED Flash in Unison	Description
5 flashes followed by several rapid flashes	Normal power up
1 flash every 3 seconds	Contact Banner Engineering
2 flash repeating sequence	In the past 60 seconds, a cable was unplugged while active
3 flash repeating sequence	A cable is unplugged
4 flash repeating sequence	Network not enabled in the configuration
5+ flash repeating sequence	Contact Banner Engineering

PROFINET Flash Command	Meaning
<p>The Base Controller LEDs flash for 4 seconds</p> 	<p>The flashing LEDs indicate that the Base Controller is connected. It is the result of the "Flash LED" command from the PROFINET network.</p>

14.2 Input Module Status Indicators

The following information is for models XS8si and XS16si.

LED	Status	Meaning
All	Sequence: Green ON for 0.5 s Red ON for 0.5 s OFF for 0.5 s minimum	Power Applied
	OFF	Initialization Mode

LED	Status	Meaning
Power Indicator	Green: ON	Power ON
	OFF	Power OFF
	Red: Flashing	Non-Operating Lockout Condition
Transmit / Receive Indicator	Green: ON	Transmitting or receiving data
	Red: ON	No communication
	Red: Flashing	Communication fault detected OR Safety Bus communication issue
Input Indicator	Green: ON	No input faults
	Red: Flashing	Input fault detected

14.3 Output Module (Solid-State or Relay) Status Indicators

The following information is for models XS2so, XS4so, XS1ro, and XS2ro.

LED	Status	Meaning
All	Sequence: Green ON for 0.5 s Red ON for 0.5 s OFF for 0.5 s minimum	Power Applied
	OFF	Initialization Mode
Power Indicator	OFF	Power OFF
	Green: ON	Power ON
	Red: Flashing	Non-Operating Lockout Condition
Transmit / Receive Indicator	Green: ON	Transmitting or receiving data
	Red: ON	No communication
	Red: Flashing	Communication fault detected OR Safety Bus communication issue
Safety Output Indicators	OFF	Output not configured
	Green: ON	Two single-channel Safety Outputs (both ON) OR Dual-channel or One single-channel Safety Output ON
	Red: ON	Two single-channel Safety Outputs (1 ON and 1 OFF)
	Red: ON	Two single-channel Safety Outputs (both OFF) OR Dual-channel or One single-channel Safety Output OFF (other channel not used)
	Red: Flashing	Safety Output fault detected

14.4 EtherCAT[®] Communication Gateway Module Status Indicators

The following information is for model XSeCAT.

LED	Status	Meaning
Power/Fault (System LED) Tx/Rx (System LED)	OFF	Initialization Mode

LED	Status	Meaning
	Sequence: Green ON for 0.5 s Red ON for 0.5 s OFF for 0.5 s minimum	Power applied
Power/Fault (System LED)	OFF	Power OFF
	Green: ON	Power ON
	Green: Flashing	New configuration downloading (and a previous configuration contained EtherCAT)
	Red: Flashing	Non-operating Lockout Condition
Tx/Rx (System LED)	Green: ON	Transmitting or receiving data
	Red: ON	No communications
RUN (EtherCAT LED)	OFF	The device is in the state INIT
	Green: Flashing 200 ms ON/200 ms OFF	The device is in the state Pre-Operational
	Green: Single flash	The device is in the state Safe-Operational
	Green: ON	The device is in the state Operational
ERROR (EtherCAT LED)	OFF	No errors
	Red: Double flash	Process Data Watchdog Timeout/EtherCAT Watchdog Timeout—most likely a cable was unplugged while the system was running
	Red: Single flashing	Local Error—most likely a new configuration is loading into the Base Controller
	Red: Flashing 200 ms ON/200 ms OFF	Invalid configuration
L/A IN (EtherCAT LED)	OFF	No EtherCAT connection detected
	Green: ON	Cable connection detected, but no communication detected
	Green: Flashing 50 ms ON/50 ms OFF	Cable connection detected and communication detected
L/A OUT (EtherCAT LED)	OFF	No EtherCAT connection detected
	Green: ON	Cable connection detected, but no communication detected
	Green: Flashing 50 ms ON/50 ms OFF	Cable connection detected and communication detected

14.5 SC10-2 LED Status

Use the following table to determine the status of the Safety Controller.

The LEDs are always on unless the Safety Controller is off.

LED	Status	Meaning
All	OFF	Initialization Mode
	Sequence: Green ON for 0.5 s Red ON for 0.5 s OFF for 0.5 s minimum	Power applied
Power/Fault (1)	Green: Solid	24 V DC connected
	Green: Flashing	Configuration or Manual Power-Up mode Configuration via SC-XM3: Cycle Power
	Red: Flashing	Non-operating Lockout condition

LED	Status	Meaning
USB (1)	Green: Solid	USB cable connected or SC-XM3 plugged in
	Green: Flashing	Factory default Safety Controller; no USB cable connected or SC-XM3 plugged in
	Green: Fast flashing for 3 s, then solid	Configured (locked or unlocked) SC-XM3 plugged into a factory default Safety Controller; the configuration, network settings, and passwords transfer from the SC-XM3 to the Safety Controller
	Green: Flashing for 3 s, then solid	Configured and unlocked SC-XM3 plugged into a configured Safety Controller with a matching configuration and matching passwords  Note: If there are mismatched network settings, the network settings transfer from the Safety Controller to an unlocked SC-XM3. Network settings do not transfer to a locked SC-XM3.
	Green: Flashing for 3 s, then Red flashing	Configured and locked SC-XM3 plugged into a configured Safety Controller with a matching configuration and matching passwords, but mismatched network settings
	Red: Solid	Configured Safety Controller; no USB cable connected or SC-XM3 plugged in
	Red: Flashing	Configured (locked or unlocked) SC-XM3 plugged into a configured Safety Controller with a mismatched configuration, a mismatched password, or a blank SC-XM3 plugged into any Safety Controller
Inputs (10)	Green: Solid	Configured as an input circuit: 24 V DC and no fault
	Green: Solid	Configured as a status output: Active
	Red: Solid	Configured as an input circuit: 0 V DC and no fault
	Red: Solid	Configured as a status output: Inactive
	Red: Flashing	All terminals of a faulted input (includes shared terminals)
RO1, RO2 (2)	Green: Solid	ON (contacts closed)
	Red: Solid	OFF (contacts open) or not configured
	Red: Flashing	Safety Output fault detected or EDM fault detected or AVM fault detected

Ethernet Diagnostic LEDs		
Amber LED	Green LED	Description
ON	Varies with traffic	Link established/normal operation
OFF	OFF	Hardware failure

Amber LED and Green LED Flash in Unison	Description
5 flashes followed by several rapid flashes	Normal power up
1 flash every 3 seconds	Contact Banner Engineering
2 flash repeating sequence	In the past 60 seconds, a cable was unplugged while active
3 flash repeating sequence	A cable is unplugged
4 flash repeating sequence	Network not enabled in the configuration
5+ flash repeating sequence	Contact Banner Engineering

PROFINET Flash Command	Meaning
<p>All LEDs flash for 4 seconds</p> 	<p>The flashing LEDs indicate that the SC10-2 is connected. It is the result of the "Flash LED" command from the PROFINET network.</p>

14.6 Live Mode Information: Software

To display real-time Run mode information on a PC, the Safety Controller must be connected to the computer via the SC-USB2 cable. Click  **Live Mode** to access the **Live Mode** tab. This feature continually updates and displays data, including Run, Stop, and Fault states of all inputs and outputs, as well as the Fault Codes table. The **Equipment** tab and the **Functional View** tab also provide device-specific visual representation of the data. See [Live Mode](#) on page 128 for more information.

The **Live Mode** tab provides the same information that can be viewed on the Safety Controller display (models with display).

14.7 Live Mode Information: Onboard Interface

To display real-time Run mode information on the Safety Controller display (models with display), select **System Status**⁷⁴ from the **System Menu** (see [XS/SC26 Onboard Interface](#) on page 163 for navigation map). **System Status** shows input device and Safety Output states; **Fault Diagnostics** shows current Fault information (a brief description, remedial step(s), and the Fault Code) and provides access to the **Fault Log**. For more information, see [XS/SC26 Onboard Interface](#) on page 163.

The Safety Controller display provides the same information that can be viewed via the **Live Mode** function in the Software.

14.8 Lockout Conditions

Input lockout conditions are generally resolved by repairing the fault and cycling the input Off and then back On.

Output lockout conditions (including EDM and AVM faults) are resolved by repairing the fault and then cycling the Reset Input connected to the FR node on the Safety Output.

System faults, such as low supply voltage, overtemperature, voltage detected on unassigned inputs, or Press Control faults may be cleared by cycling the System Reset input (any Reset Input assigned to be the System Reset). Only one reset button, either physical or virtual, can be configured to perform this operation.

A system reset is used to clear lockout conditions not related to safety inputs or outputs. A lockout condition is a response where the Safety Controller turns Off all affected Safety Outputs when a safety-critical fault is detected. Recovery from this condition requires all faults to be remedied and a system reset to be performed. A lockout will recur after a system reset unless the fault that caused the lockout has been corrected.

A system reset is necessary under the following conditions:

- Recovering from a system lockout condition
- Starting the Safety Controller after a new configuration has been downloaded
- Recovering from a Press Control fault

For internal faults, the System Reset likely will not work. The power will have to be cycled in an attempt to run again.

⁷⁴ **System Status** is the first screen that displays when the Safety Controller turns On after a reset. Click **ESC** to view the **System Menu**.

**WARNING:**

- **Non-monitored resets**
- Failure to follow these instructions could result in serious injury or death.
- If a non-monitored reset (either latch or system reset) is configured and if all other conditions for a reset are in place, a short from the reset terminal to +24 V will turn on the safety output(s) immediately.

**WARNING:**

- **Clear the guarded area before applying power or resetting the system**
- Failure to clear the guarded area before applying power could result in serious injury or death.
- Verify that the guarded area is clear of personnel and any unwanted materials before applying power to the guarded machine or before resetting the system.

14.9 Recovering from a Lockout

To recover from a lockout condition:

- Follow the recommendation in the fault display (models with display)
- Follow the recommended steps and checks listed in the [XS/SC26 Fault Code Table](#) on page 335 or [SC10-2 Fault Code Table](#) on page 340
- Perform a system reset
- Cycle the power and perform a system reset, if needed

If these steps do not remedy the lockout condition, contact Banner Engineering (see [Repairs and Warranty Service](#) on page 344).

14.10 AutoDetect ISD Option

The **AutoDetect ISD** feature is available on XS26-ISD FID 5 or later.

Figure 291. ISD Device Properties—AutoDetect ISD Selected

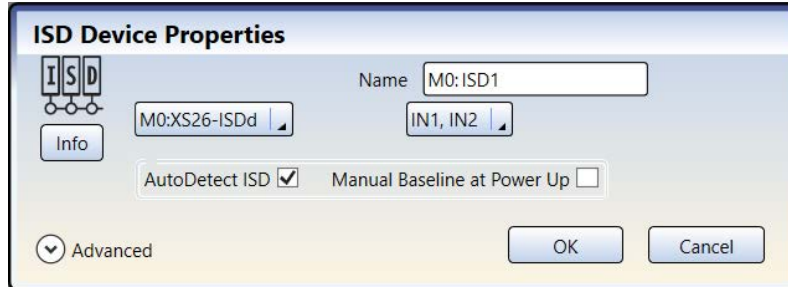

The **AutoDetect ISD** selection is a universal selection. It changes all ISD channels to Automatic Configuration, not just the one currently selected in the **ISD Device Properties** box. It also deletes any entries that have already been created in other ISD chains. Clearing the **AutoDetect ISD** checkbox does **not** return these entries (the undo button can return previous entries). When changing to **AutoDetect ISD** the following notice displays, allowing you to cancel the change:

Figure 292. AutoDetect Change Confirmation

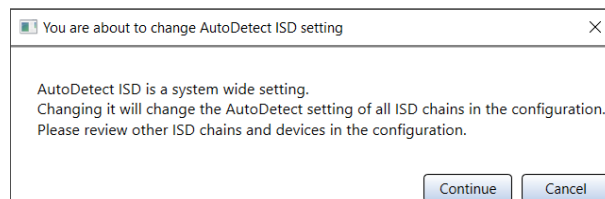

Selecting the **AutoDetect ISD** checkbox allows the safety controller to monitor more than the length and composition of ISD chains. When **AutoDetect ISD** is selected, the controller updates the configuration to match the new chain configurations (chain changes). The controller provides this composition to a PLC so that it can be verified as a valid configuration. The changes also display in the **Live Mode** view of the Banner Safety Controller software for manual verification.



Note: The controller's safety response is based on the state of the OSSDs of the ISD inputs, not the ISD information carried on the OSSDs. The ISD information is non-safety chain and/or device status information.

When **AutoDetect ISD** is selected, the controller queries each of the configured ISD input chains to determine their device count, position, and type. The controller provides this information to the attached Banner Safety Controller software and/or PLC to verify it is correct for the given system.

- At power up the controller queries the configured ISD chains to determine their device count, device position, and type, and sets this as the baseline configuration of the chain. It passes this information to the controller software and/or an attached PLC to verify the information is correct. The controller does not notify the user of any changes that might have been made when the power was off.
- When **AutoDetect ISD** is selected, the **Manual Baseline Power Up** checkbox is available. If this box is selected, the controller will set the "Re-baseline" bit to the software and/or connected PLC. The "Accept this Baseline" bit must be returned to the controller to set the baseline. If the box is clear, the controller automatically accepts the existing configuration of all connected ISD chains. The **Manual Baseline Power Up** feature is a universal selection; selecting it for one chain applies it to all chains. Remember that the controller's safety response is based on the state of the OSSDs of the ISD inputs, not the ISD information.
- During operation, the controller notifies the user that a change has been detected in a specific ISD chain. If connected to the controller and in Live Mode, the following displays:

Figure 293. Re-baseline Button Available

		Status	Alert	Actuator
	Name	On	Marginal	Detected
		Off	Warning	
		Reset	Fault	
1	Device1			
2	Device2			
3	Device3			
4	Device4			
5	Device5			
	ISD5			

Different from Baseline

Change Detected

When chain changes are detected, the view of the chain automatically updates to the new configuration. Below the changed chain, you might first see a notification that the ISD data is delayed. After the data is updated, the Chain Changed notice displays for 15 seconds. If the chain is different from what it was when it power up (baseline), the notice that the configuration is different from the baseline displays. If the change is acceptable it can be set as the new baseline by clicking **Re-baseline**. The controller also notifies the attached PLC that a chain has changed. The Chain Change Detected bit of the cyclic data for the affected chain is set to 1. It is cleared by acknowledging the change.

Because the controller does not know if the ISD chain connected to any input pair is correct, it is the responsibility of the user to make sure that the detected chain of ISD devices is correct. This can be done by:

- Physically checking the number of devices against the documentation
- Checking the Live Mode ISD display against the documentation
- Reading the data into the PLC and comparing it to the loaded information for the specific machine structure

It can take the controller a few seconds to detect a change in the number of ISD devices in a chain. The controller detects the removal of the terminating plug and/or loss of the ISD information (for example, when the chain is severed between units). This information is part of the cyclic data that is passed between the controller and the PLC.

 **Note:** The ISD chain's OSSDs quickly turn off in either of these situations (within the response time of the ISD chain).

In most situations, the controller cannot detect a change in chain length until the chain has been completed (for example, the terminating plug removed, devices added, then the terminating plug re-installed). The OSSD outputs can be returned to the ON state after the terminating plug has been re-installed. The ISD information takes a few seconds to start transmitting again because the starting device may have changed.

The simplest way to ensure that the machine cannot start after a chain configuration change is to map the chain to a manual reset block (or to an output with an LR (latch reset) node selected) in the configuration. This requires operator action to re-arm the safety system every time the chain's OSSD outputs turn OFF then back ON. Then the operator has to re-start the machine. However, this process does not require the operator (or anything else) to verify that the new ISD chain structure is correct.

If a user desires to keep the machine in an OFF state until the operator has verified that the chain's length is correct for the current machine structure, configure the PLC to require a specific operator action every time the Terminating Plug Missing flag is turned ON for a chain. This operator action is either manually verifying the configuration is correct or selecting a function on the PLC for it to verify the configuration is correct.

 **Note:** It is the responsibility of the machine builder (user) to ensure the wiring/cabling is not easily manipulated by an operator to defeat the safety function(s); for example, cannot remove a switch from the system.

For a system where the ISD chains should not change, that is, the ISD chains are taught at machine installation, the machine builder (user) must ensure the wiring/cabling is not easily manipulated by an operator to defeat the safety function(s) of ISD devices.

For a system where the ISD chains can change during operation (for example, adding and removing carts from a trolley system), the machine builder (user) must ensure that the only changes that can be made to the wiring/cabling are those involved in the addition or removal of the appropriate machine sections. Perform a system verification after each machine change either automatically via a PLC or manually by an operator.

 **Note:** If a controller is set for Automatic Configuration and the configuration is read into the software, clearing the **AutoDetect ISD** checkbox deletes all of the received ISD inputs. To create a permanent configuration from one that is set to Auto Configuration, read the configuration from the controller, and then print it out. A new configuration can then be created from the printout (the ISD chains can be recreated after the **AutoDetect ISD** checkbox is cleared).

 **Note:** When **AutoDetect ISD** is selected, device #1 is closest to the controller. The device numbers increase the further they are away from the controller, toward the terminating plug. When the ISD devices are manually entered, device #1 is closest to the terminating plug. The device numbers increase the closer they are to the controller.

14.11 SC10-2 Using Automatic Terminal Optimization



Follow these steps for an example configuration that uses the Automatic Terminal Optimization (ATO) feature.

 **Note:** This procedure is an example only.

1. Click **New Project** to start a new project.
2. Select SC10-2 **Series**.
3. Define the project settings and click **OK**.

 **Note:** Make sure that **Disable Automatic Terminal Optimization Feature** checkbox is clear.

The project is created.

4. On the **Equipment** tab, click  below the Safety Controller. The **Add Equipment** window opens.
5. Add an Emergency Stop button, and click **OK** to accept the default settings.
6. Click .
7. Add an Optical Sensor, and click **OK** to accept the default settings.
8. Click .

9. Add a Gate Switch, and click **OK** to accept the default settings.
10. Go to the **Wiring Diagram** tab, and notice the terminals that are used.

Figure 294. **Wiring Diagram** tab with an E-stop button, optical sensor, and gate switch

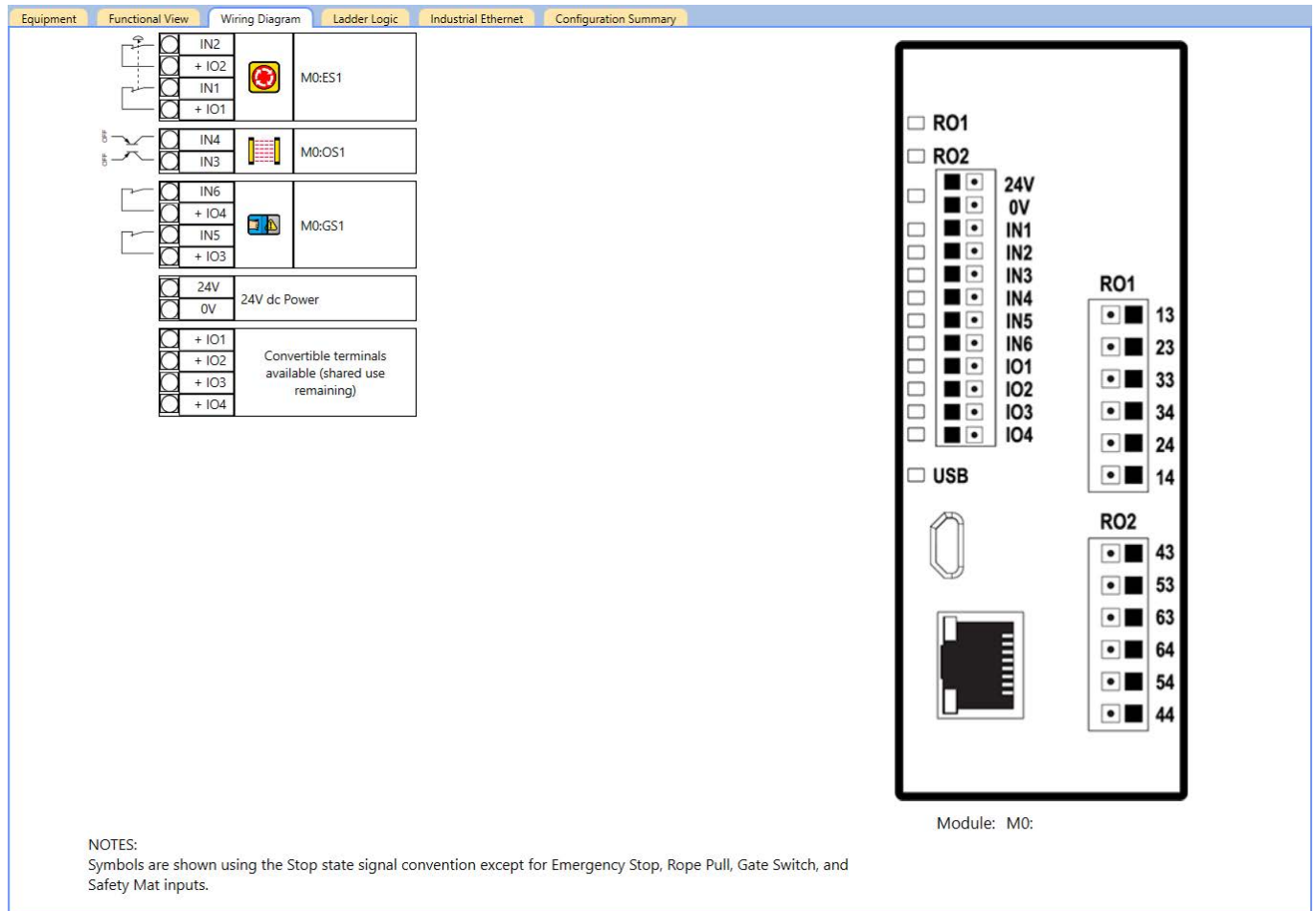

11. Go to the **Equipment** tab and click **+**.
12. Add a second Gate Switch, and click **OK** to accept the default settings.
13. Go to the **Wiring Diagram** tab, and notice that external terminal blocks (ETB) have been added to accommodate the second Gate Switch.



Note: External terminal blocks are user-provided.

Figure 295. Wiring Diagram Tab with Three E-stop Buttons and ETBs

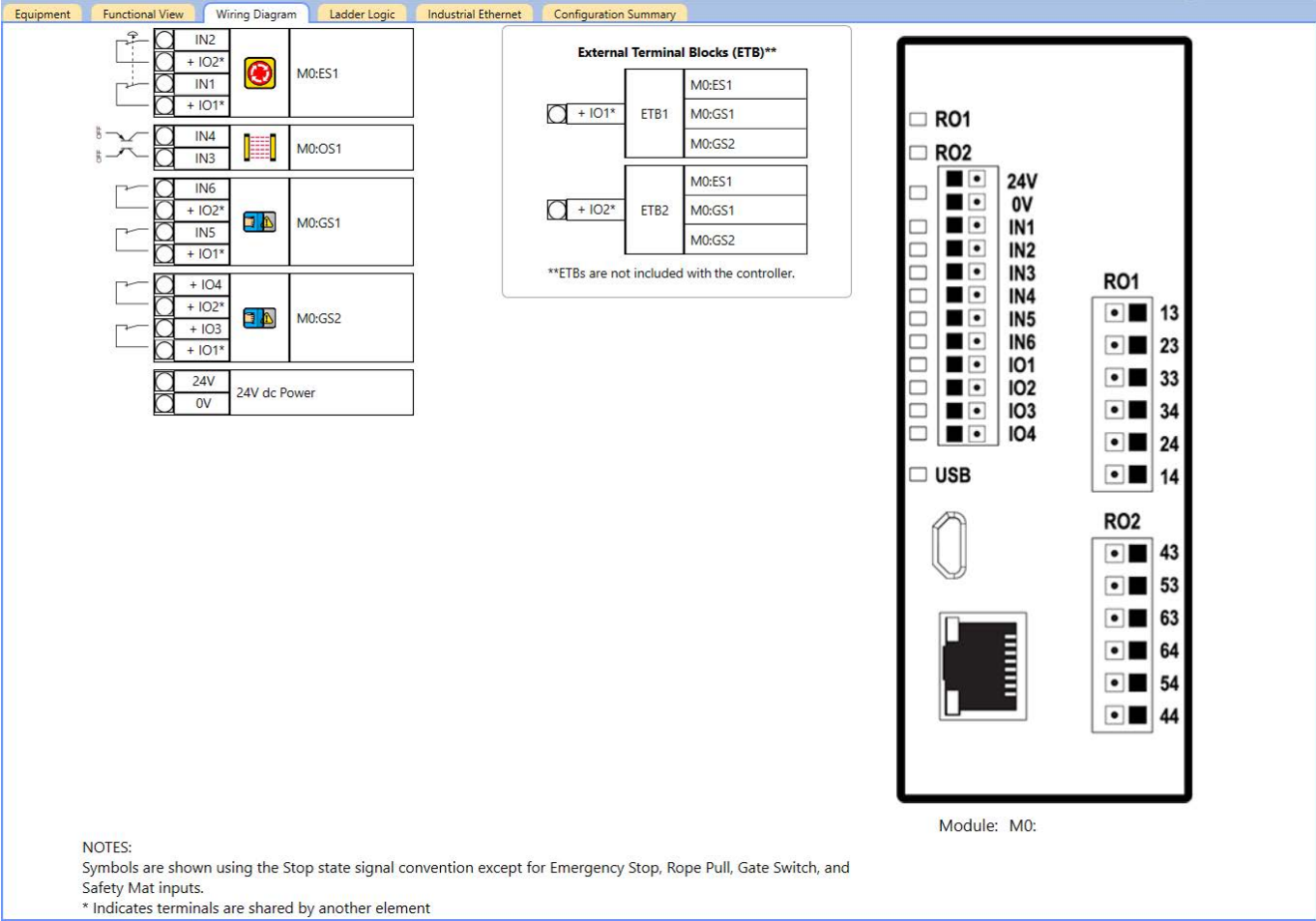

14.12 SC10-2 Example Configuration without Automatic Terminal Optimization

Follow these steps for an example configuration where the Automatic Terminal Optimization (ATO) feature is disabled.

Note: This procedure is an example only.

1. Click **New Project** to start a new project.
2. Select SC10-2 **Series**.
3. Define the project settings, select the **Disable Automatic Terminal Optimization Feature** checkbox, and click **OK**.



Note: Make sure that **Disable Automatic Terminal Optimization Feature** checkbox is selected.

Figure 296. Disable Automatic Terminal Optimization Feature Selected

The project is created.



4. On the **Equipment** tab, click  below the Safety Controller. The **Add Equipment** window opens.
5. Add an Emergency Stop button, and click **OK** to accept the default settings.
6. Click .
7. Add an Optical Sensor, and click **OK** to accept the default settings.
8. Click .
9. Add a Gate Switch, and click **OK** to accept the default settings.
10. Go to the **Wiring Diagram** tab, and notice the terminals that are used.

Figure 297. Wiring Diagram tab with an E-stop button, optical sensor, and gate switch



11. Go to the **Equipment** tab and try to add another Gate Switch.
No other equipment can be added (+ does not appear) because the ATO feature is disabled and there are not enough terminals to support more equipment.
12. Go to the **Functional View** tab and try to add another Gate Switch.
No other equipment can be added here either because the ATO feature is disabled.
13. Click **Cancel**.
14. On the **Functional View** tab, click on the Gate Switch and then click **Edit** to change the properties.
 - a) Change the IO3 and IO4 terminals to IO1 and IO2 respectively.

Figure 298. Gate Switch Properties

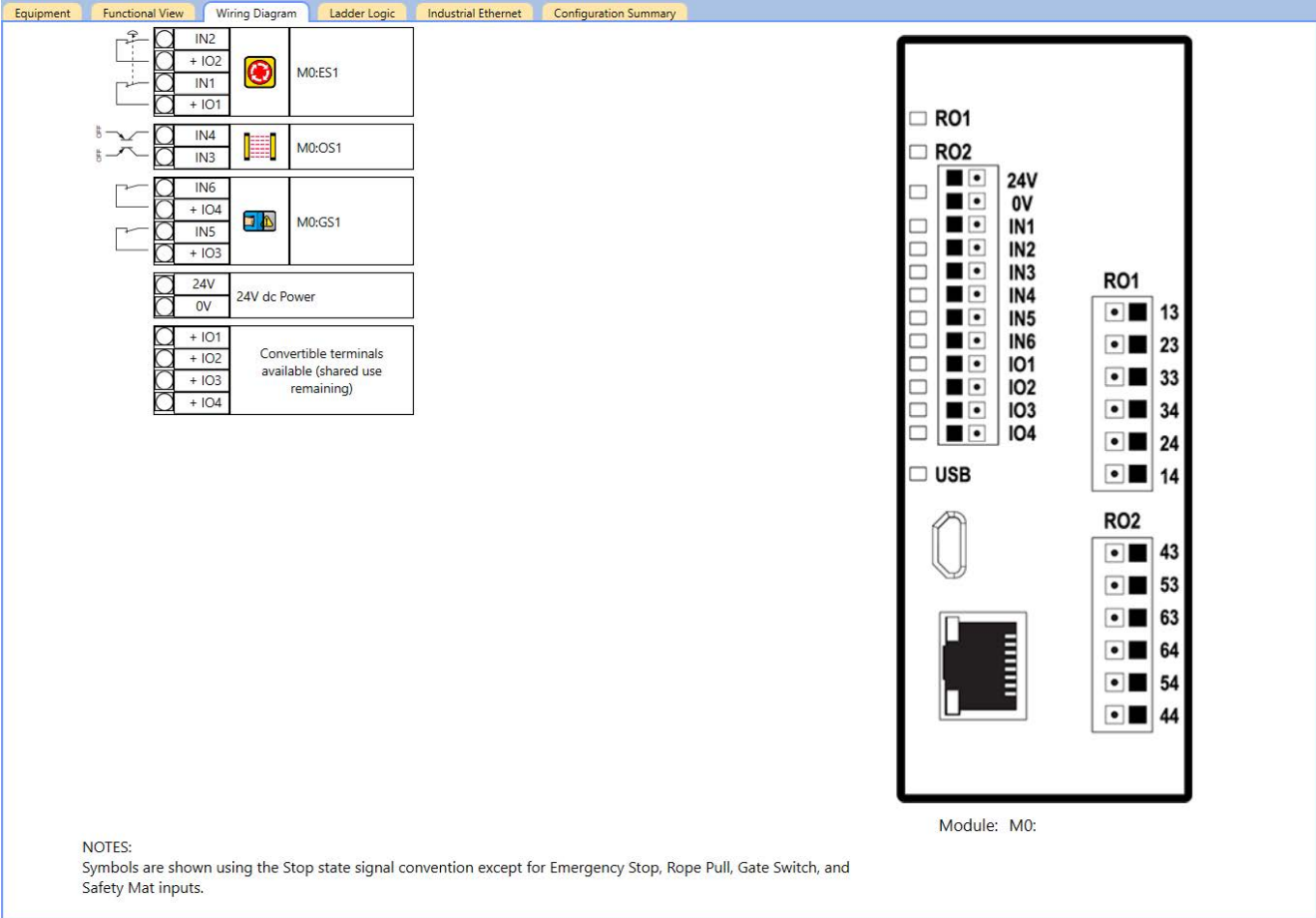
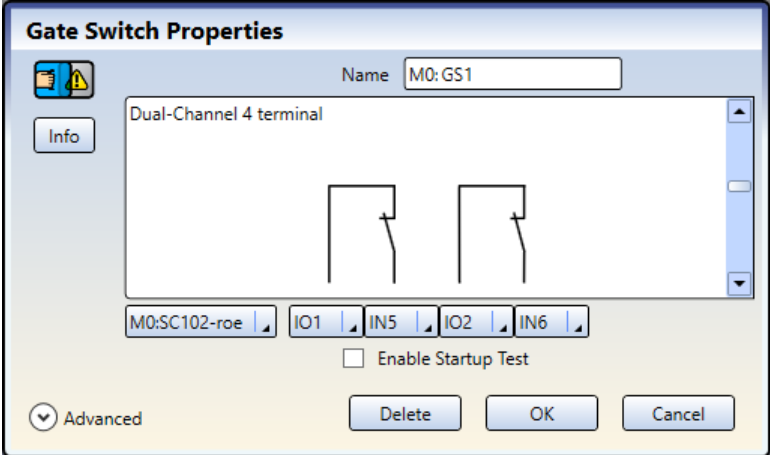
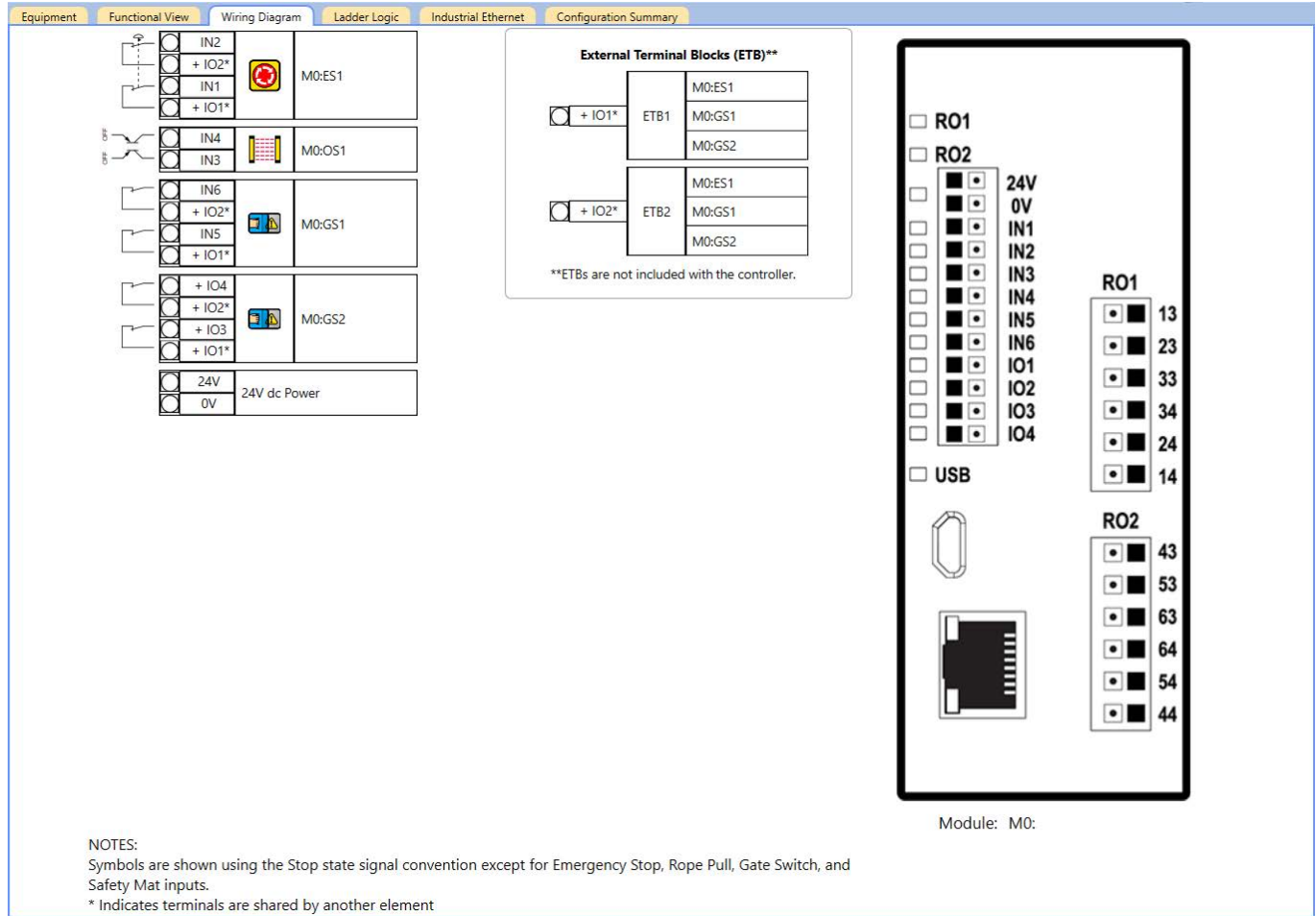

Figure 300. **Wiring Diagram** tab with an E-stop button, optical sensor, gate switches, and ETBs



14.13 XS/SC26 Models without an Onboard Interface: Using the SC-XM2/3

This procedure is for XS/SC26 and XS/SC26-2e models.

Use an SC-XM2 or SC-XM3 to:

- Store a confirmed configuration
- Quickly configure multiple XS/SC26 Safety Controllers with the same configuration (FID 3 and later)
- Replace one XS/SC26 Safety Controller with another using the SC-XM2/3 (FID 3 and later)

Note: The Banner programming tool (SC-XMP2) and Banner Safety Controller Software are required to write a confirmed configuration to an SC-XM2/3. This limits access to authorized personnel.

1. Create the desired configuration using the Software.
 Using the latest version of the Software is recommended, however some functions are not available to older Safety Controllers. See the Checklist on the left side of the software screen for additional information as you create the configuration.
2. Review and confirm the configuration by loading it onto the XS/SC26.
 After review and approval, the configuration can be saved and used by the Safety Controller.
3. Write the confirmed configuration to the SC-XM2/3 using the programming tool.

Note: Only a confirmed configuration can be stored on the SC-XM2/3. See [Write a Confirmed Configuration to an SC-XM2/3 using the Programming Tool](#) on page 91.

4. Use a label to indicate the configuration that is stored on the SC-XM2/3.
5. Install and/or connect power to the desired XS/SC26 (factory default Safety Controller or configured Safety Controller).

- **FID 1 or FID 2 Controllers:** The USB LED is off.
- **FID 3 or later Controllers:** The USB LED flashes green if the XS/SC26 is a factory default Safety Controller. The USB LED is off if the Safety Controller is a configured controller.



Note: The factory default setting is based on the safety micros. Changing the default IP address does not change this setting. Configuring such a unit with the SC-XM2/3 will overwrite the network settings.

6. Insert the SC-XM2/3 into the micro USB port on the XS/SC26.



Note: For additional information regarding the LEDs, see [XS/SC26 LED Status](#) on page 307.

FID 1 or FID 2 Safety Controller

- If the USB LED flashes green for 5 seconds, the configuration on the Safety Controller and the SC-XM2/3 match.
- If the USB LED flashes red for 5 seconds, the configuration on the Safety Controller and the SC-XM2/3 do not match.

FID 3 or later Factory Default Safety Controller

- If the USB LED flashes green for 4 seconds, then stays on, the configuration, network settings, and passwords automatically download to the Safety Controller.
- If the USB LED flashes red for 5 seconds, the configuration on the SC-XM2/3 was created using an older version of the Software (4.1 or earlier) or using an FID 2 or earlier Safety Controller and is inserted into an FID 3 or later Safety Controller. This means that the configuration cannot automatically be loaded unless the SC-XM2/3 configuration is re-created using software version 4.2 or later or using an FID 3 or later Safety Controller with a display.

FID 3 or later Configured Safety Controller

- If a SC-XM2/3 with an old configuration ⁷⁵ SC-XM2/3 is inserted and the USB LED flashes green for 5 seconds, the configuration on the Safety Controller and the SC-XM2/3 match.
 - If a SC-XM2/3 with an old configuration ⁷⁵ is inserted and the USB LED flashes red for 5 seconds, the configuration on the SC-XM2/3 does not match.
 - If a SC-XM2/3 with a new configuration ⁷⁶ is inserted and the USB LED flashes green for 5 seconds, the configuration and passwords on the Safety Controller and the SC-XM2/3 match. Also, if the network settings do not match (XS/SC26-2e models), the network settings of the Safety Controller transfer to the SC-XM2/3, as long as the SC-XM2/3 is not locked. If the SC-XM2/3 is locked, the USB LED flashes red for 5 seconds and if the SC-XM2/3 is not removed during these 5 seconds, the Safety Controller enters a lockout state.
 - If a SC-XM2/3 with a new configuration ⁷⁶ is inserted and the USB LED flashes red, the configuration or the passwords on the Safety Controller and the SC-XM2/3 do not match. If the SC-XM2/3 is not removed within 5 seconds, the power/fault LED flashes red and the Safety Controller enters a lockout state.
7. If the Safety Controller entered a lockout state, remove the SC-XM2/3 and cycle the power or perform a system reset.
 8. For factory default FID 3 or later Safety Controllers: When the USB LED stops fast flashing, cycle the power or perform a system reset.

The Safety Controller is ready for commissioning. See [Commissioning Checkout Procedure](#) on page 299.



Note: If the industrial protocol PROFINET was being used on the replaced controller, use the PLC to assign the same PROFINET name to the replacement controller.

14.14 XS/SC26 Models with an Onboard Interface: Using the SC-XM2/3

The following procedures are for XS/SC26-2d, XS/SC26-2de, and XS26-ISDd models.

Use an SC-XM2 or SC-XM3 to:

- Store a confirmed configuration
- Quickly configure multiple XS/SC26 Safety Controllers with the same configuration
- Replace one XS/SC26 Safety Controller with another using the SC-XM2/3 (FID 3 or later feature)

⁷⁵ "Old configuration": an SC-XM2/3 that contains information that was created using the Banner Safety Controller Software Version 4.1 or earlier, or that was created from an FID 2 or earlier Safety Controller.

⁷⁶ "New configuration": an SC-XM2/3 that contains information that was created using the Banner Safety Controller Software Version 4.2 or later, or that was created from an FID 3 or later Safety Controller.

Note: The Banner programming tool (SC-XMP2) and Banner Safety Controller Software are required to write a confirmed configuration to an SC-XM2/3. This limits access to authorized personnel. A configuration may also be written to an SC-XM2/3 using a Safety Controller with an onboard interface (XS/SC26-2d, -2de, and -ISDd models).

Note: The LEDs behave the same way with or without an onboard interface (for more details, see [XS/SC26 Models without an Onboard Interface: Using the SC-XM2/3](#) on page 321), however the following procedure focuses on what happens on the display.

14.14.1 XS/SC26 FID 1 or FID 2 Controllers with an Onboard Interface: Using the SC-XM2/3

This procedure is for XS/SC26-2d and XS/SC26-2de models.

1. Create the desired configuration using the Software.
Using the latest version of the Software is recommended, however some functions are not available to older Safety Controllers. See the Checklist on the left side of the software screen for additional information as you create the configuration.
2. Review and confirm the configuration by loading it onto a XS/SC26.
After review and approval, the configuration can be saved and used by the Safety Controller.
3. Write the confirmed configuration to the SC-XM2/3 using the programming tool or the onboard interface (XS/SC26-2d and -2de models).

Note: Only a confirmed configuration can be stored on the SC-XM2/3.

4. Use a label to indicate the configuration that is stored on the SC-XM2/3.
5. Install and/or connect power to the desired XS/SC26 (factory default Safety Controller or configured Safety Controller).
The USB LED is off.
6. Insert the SC-XM2/3 into the micro USB port on the XS/SC26.
 - If a SC-XM2/3 with an old configuration ⁷⁷ or a SC-XM2/3 with a new configuration ⁷⁸ is plugged into a configured FID 1 or FID 2 Safety Controller, one of the following screens displays based on whether or not the configuration matches the Safety Controller:

Figure 301. Match



Figure 302. Mismatch



For instructions on importing data from the SC-XM2/3, see [XS/SC26 Configuration Mode](#) on page 164.

- If a blank SC-XM2/3 is plugged into a configured FID 1 or FID 2 Safety Controller, the display indicates the issue:

Figure 303. Blank SC-XM2/3

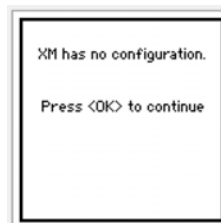

⁷⁷ "Old configuration": an SC-XM2/3 that contains information that was created using the Banner Safety Controller Software Version 4.1 or earlier, or that was created from an FID 2 or earlier Safety Controller.

⁷⁸ "New configuration": an SC-XM2/3 that contains information that was created using the Banner Safety Controller Software Version 4.2 or later, or that was created from an FID 3 or later Safety Controller.

The Safety Controller is ready for commissioning. See [Commissioning Checkout Procedure](#) on page 299.



Note: If the industrial protocol PROFINET was being used on the replaced controller, use the PLC to assign the same PROFINET name to the replacement controller.

14.14.2 XS/SC26 FID 3 and Later Controllers with an Onboard Interface: Using the SC-XM2/3

This procedure is for XS/SC26-2d, XS/SC26-2de, and XS26-ISDd models.

1. Create the desired configuration using the Software.
Using the latest version of the Software is recommended, however some functions are not available to older Safety Controllers. See the Checklist on the left side of the software screen for additional information as you create the configuration.
2. Review and confirm the configuration by loading it onto a XS/SC26.
After review and approval, the configuration can be saved and used by the Safety Controller.
3. Write the confirmed configuration to the SC-XM2/3 using the programming tool or the onboard interface (XS/SC26-2d and -2de models and XS26-ISDd models).



Note: Only a confirmed configuration can be stored on the SC-XM2/3.

4. Use a label to indicate the configuration that is stored on the SC-XM2/3.
5. Install and/or connect power to the desired XS/SC26 (factory default Safety Controller or configured Safety Controller).
 - The USB LED flashes green if the XS/SC26 is a factory default Safety Controller
 - The USB LED is off if the Safety Controller is a configured controller



Note: The factory default setting is based on the safety micros. Changing the default IP address does not change this setting. Configuring such a unit with the SC-XM2/3 will overwrite the network settings.

6. Insert the SC-XM2/3 into the micro USB port on the XS/SC26.

Factory Default Safety Controller

- If the FID of the configuration does not match the FID of the Safety Controller, the configuration will not match. The display indicates the issue and begins the count down to a system lockout:

Figure 304. FID Mismatch



- If the configuration includes ISD, but the Safety Controller is not an XS26-ISD, the configuration is rejected. The display indicates the issue and begins the count down to a system lockout:

Figure 305. ISD Mismatch



- If a SC-XM2/3 with a new configuration ⁷⁹ is plugged into a factory default FID 3 or later Safety Controller, the configuration, network settings, and passwords automatically download to the Safety Controller. The display indicates the autoload:

⁷⁹ "New configuration": an SC-XM2/3 that contains information that was created using the Banner Safety Controller Software Version 4.2 or later, or that was created from an FID 3 or later Safety Controller.

Figure 306. Autoload Status



After the autoload is done, the display shows: "Config received, please power cycle or system reset".

- If a SC-XM2/3 with an old configuration⁸⁰ is plugged into a factory default FID 3 or later Safety Controller, the configuration will not match:

Figure 307. Mismatch



- If a blank SC-XM2/3 is plugged into a factory default FID 3 or later Safety Controller, the display indicates the issue and begins the count down to a system lockout:

Figure 308. SC-XM2/3 Error



If the SC-XM2/3 is not disconnected from the Safety Controller within 3 seconds, the Safety Controller enters a lockout state:

Figure 309. System Lockout



Configured Safety Controller

- If a SC-XM2/3 with an old configuration⁸⁰ is plugged into a configured FID 3 or later Safety Controller, one of the following screens displays based on whether or not the configuration matches the Safety Controller:

⁸⁰ "Old configuration": an SC-XM2/3 that contains information that was created using the Banner Safety Controller Software Version 4.1 or earlier, or that was created from an FID 2 or earlier Safety Controller.

Figure 310. Match



Figure 311. Mismatch



For instructions on importing data from the SC-XM2/3, see [XS/SC26 Configuration Mode](#) on page 164.

- If a SC-XM2/3 with a new configuration ⁷⁹ is plugged into a configured FID 3 or later Safety Controller and the configuration and password match, one of the following displays:

Figure 312. XS/SC26-2d Models: Network settings ignored



Figure 313. XS/SC26-2de and XS26-ISDd Models: Network settings match



Also, if the network settings do not match (XS/SC26-2de models), the network settings of the Safety Controller transfer to the SC-XM2/3. When this is complete, the display shows the following:

Figure 314. Network Update



Click **OK**. If the update fails (for example, the SC-XM2/3 is locked), the display indicates why it failed and begins the countdown to a system lockout:

Figure 315. Network Update Failed

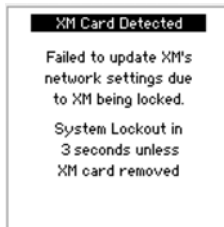

If the SC-XM2/3 is not disconnected from the Safety Controller within 3 seconds, the Safety Controller enters a lockout state:

Figure 316. System Lockout

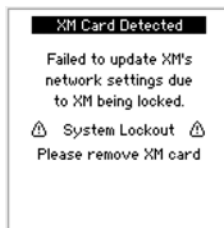

- If a SC-XM2/3 with a new configuration ⁷⁹ is plugged in a configured FID 3 or later Safety Controller, but the configuration and/or the password do not match, the display indicates the issue and begins the count down to a system lockout:

Figure 317. XS/SC26-2d Models: Mismatch



Figure 318. XS/SC26-2de Models: Mismatch



If the SC-XM2/3 is not disconnected from the Safety Controller within 3 seconds, the Safety Controller enters a lockout state:

Figure 319. XS/SC26-2d Models: System Lockout



Figure 320. XS/SC26-2de Models: System Lockout



For instructions on importing data from the SC-XM2/3, see [XS/SC26 Configuration Mode](#) on page 164.

- If a blank SC-XM2/3 is plugged into a configured FID 3 or later Safety Controller, the display indicates the issue and begins the count down to a system lockout:

Figure 321. SC-XM2/3 Error



If the SC-XM2/3 is not disconnected from the Safety Controller within 3 seconds, the Safety Controller enters a lockout state:

Figure 322. System Lockout



7. If the Safety Controller entered a lockout state, remove the SC-XM2/3 and cycle the power or perform a system reset.
8. For factory default Safety Controllers: When the USB LED stops fast flashing, cycle the power or perform a system reset.

The Safety Controller is ready for commissioning. See [Commissioning Checkout Procedure](#) on page 299.



Note: If the industrial protocol PROFINET was being used on the replaced controller, use the PLC to assign the same PROFINET name to the replacement controller.

14.15 SC10-2: Using the SC-XM3

Use an SC-XM3 to:

- Quickly configure multiple SC10-2 Safety Controllers with the same configuration
- Replace one SC10-2 Safety Controller with another using the SC-XM3 from the old Safety Controller



Note: The Banner programming tool (SC-XMP2) and Software are required to write a confirmed configuration to an SC-XM3. This limits access to authorized personnel.

1. Create the desired configuration using the Software.
2. Review and confirm the configuration by loading it onto an SC10-2.
After review and approval, the configuration can be saved and used by the Safety Controller.
3. Write the confirmed configuration to the SC-XM3 using the programming tool.



Note: Only a confirmed configuration can be stored on the SC-XM3. See [Write a Confirmed Configuration to an SC-XM2/3 using the Programming Tool](#) on page 91.

4. Use a label to indicate the configuration that is stored on the SC-XM3.
5. Install and/or connect power to the desired SC10-2 (factory default Safety Controller or configured Safety Controller).
 - If the SC10-2 is a factory default Safety Controller, the power/fault LED is on green and the USB LED flashes green to indicate that the Safety Controller is waiting for a configuration.
 - If the SC10-2 is a configured Safety Controller, the power/fault LED is on green and the USB LED is on red.



Note: The factory default setting is based on the safety micros. Changing the default IP address does not change this setting. Configuring such a unit with the SC-XM2/3 will overwrite the network settings.

6. Insert the SC-XM3 into the micro USB port on the SC10-2.

Factory Default Safety Controller

- The USB LED fast flashes for 3 seconds, then stays on, and the configuration, network settings, and passwords automatically download to the Safety Controller. Then, the power/fault LED flashes green to indicate that the Safety Controller is waiting for a power cycle.

Configured Safety Controller

- If the configuration and passwords on the Safety Controller and the SC-XM3 match, the USB LED flashes green for 3 seconds and then stays on. Also, if the network settings do not match, the network settings of the Safety Controller transfer to the SC-XM3 after 3 seconds, as long as the SC-XM3 is not locked. If the SC-XM3 is locked, the controller enters a lockout state.
- If the configuration or the passwords on the Safety Controller and the SC-XM3 do not match, the USB LED flashes red. If the SC-XM3 is not disconnected from the Safety Controller within 3 seconds, the power/fault and USB LEDs flash red and the Safety Controller enters a lockout state due to the mismatch.

7. Cycle the power.

The power/fault LED is green, the USB LED is green (if the SC-XM3 is still plugged in) or red (no SC-XM3 or USB cable connected), and the Input and Output LEDs show actual input status.

The Safety Controller is ready for commissioning. See [Commissioning Checkout Procedure](#) on page 299.

14.16 Reset the Safety Controller to Factory Defaults

Use the following procedure to reset the XS/SC26 with FID 3 or later or the SC10-2 Safety Controller to the factory default settings.



Note: XS/SC26 with FID 1 or FID 2 using Software version 4.2 or later will show the **Reset to Factory Default** option in gray.

The Safety Controller must be powered up and connected to the PC via the SC-USB2 cable.

1. Click .
2. Click **Reset to Factory Default**.
A caution displays reminding you that all settings will change to factory defaults.
3. Click **Continue**.
The **Enter Password** screen opens.

4. Enter the User1 password and click **OK**.
The Safety Controller is updated to the factory default settings and a confirmation window displays.
5. Click **OK**.
6. Cycle the power.
The reset to factory default process is complete.

14.17 Factory Defaults

The following table lists some of the factory default settings for both the Safety Controller and the Software.

Setting	Factory Default	Applicable Product
AVM Function	50 ms	XS/SC26, SC10-2
Closed-to-Open Debounce Time	6 ms	XS/SC26, SC10-2
EDM	No monitoring	XS/SC26, SC10-2
Function Block: Bypass Block—Default Nodes	IN, BP	XS/SC26, SC10-2
Function Block: Bypass—Time Limit	1 s	XS/SC26, SC10-2
Function Block: Delay Block—Default Nodes	IN	XS/SC26, SC10-2
Function Block: Delay Block—Output Delay	100 ms	XS/SC26, SC10-2
Function Block: Enabling Device Block—Default Nodes	ED, IN, RST	XS/SC26, SC10-2
Function Block: Enabling Device Block—Time Limit	1 s	XS/SC26, SC10-2
Function Block: Latch Reset Block—Default Nodes	IN, LR	XS/SC26, SC10-2
Function Block: Muting Block—Default Nodes	IN, MP1	XS/SC26, SC10-2
Function Block: Muting Block—Time Limit	30 s	XS/SC26, SC10-2
Function Block: Two-Hand Control Block—Default Nodes	TC	XS/SC26, SC10-2
Function Block: One Shot Block—Default Nodes	IN	XS/SC26
Function Block: One Shot Block—Time Limit	100 ms	XS/SC26
Industrial Ethernet: String (EtherNet/IP and PCCC Protocol)	32 bit	XS/SC26, SC10-2
Network Settings: Gateway Address	0.0.0.0	XS/SC26, SC10-2
Network Settings: IP Address	192.168.0.128	XS/SC26, SC10-2
Network Settings: Link Speed and Duplex Mode	Auto Negotiate	XS/SC26, SC10-2
Network Settings: Subnet Mask	255.255.255.0	XS/SC26, SC10-2
Network Settings: TCP Port	502	XS/SC26, SC10-2
Open-to-Closed Debounce Time	50 ms	XS/SC26, SC10-2
Password User1	1901	XS/SC26, SC10-2
Password User2	1902	XS/SC26, SC10-2
Password User3	1903	XS/SC26, SC10-2
Power up mode	Normal	SC10-2
Safety Outputs	Automatic reset (trip mode)	XS/SC26, SC10-2
Safety Outputs: Power-up Mode	Normal	XS/SC26
Safety Outputs: Split (Safety Outputs)	Function in pairs	XS/SC26
Simulation Mode: Simulation Speed	1	XS/SC26, SC10-2
Automatic Terminal Optimization	Enabled	SC10-2
Status Output Signal Conventions	Active = PNP On	XS/SC26, SC10-2
Status Output Flashing Rate	None	XS/SC26

15 Troubleshooting

The Safety Controller is designed and tested to be highly resistant to a wide variety of electrical noise sources that are found in industrial settings. However, intense electrical noise sources that produce electro-magnetic interference (EMI) or radio frequency interference (RFI) beyond these limits may cause a random trip or lockout condition.

If random trips or lockouts occur, check that:

- The supply voltage is within 24 V DC \pm 20%
- The Safety Controller's plug-on terminal blocks are fully inserted
- Wire connections to each individual terminal are secure
- No high-voltage or high-frequency noise sources or any high-voltage power lines are routed near the Safety Controller or alongside wires that are connected to the Safety Controller
- Proper transient suppression is applied across the output loads
- The temperature surrounding the Safety Controller is within the rated ambient temperature (see [Specifications and Requirements](#) on page 20)

15.1 Software: Troubleshooting

Live Mode button is unavailable (grayed out)

1. Make sure the SC-USB2 cable is plugged into both the computer and the Safety Controller.



Note: Use of the Banner SC-USB2 cable is preferred. If other USB cables are used, make sure that the cable includes a communication line. Many cell phone charging cables do not have a communication line.

2. Verify that the Safety Controller is installed properly—see [Verifying Driver Installation](#) on page 333.
3. Exit the Software.
4. Unplug the Safety Controller and plug it back in.
5. Start the Software.

Unable to read from the Safety Controller or send the configuration to the Safety Controller (buttons grayed out)

1. Make sure **Live Mode** is disabled.
2. Make sure the SC-USB2 cable is plugged into both the computer and the Safety Controller.



Note: Use of the Banner SC-USB2 cable is preferred. If other USB cables are used, make sure that the cable includes a communication line. Many cell phone charging cables do not have a communication line.

3. Verify that the Safety Controller is installed properly—see [Verifying Driver Installation](#) on page 333.
4. Exit the Software.
5. Unplug the Safety Controller and plug it back in.
6. Start the Software.

Unable to move a block to a different location

Not all blocks can be moved. Some blocks can be moved only within certain areas.

- **Safety Outputs** are placed statically and cannot be moved. **Referenced Safety Outputs** can be moved anywhere within the left and middle areas.
- **Safety** and **Non-Safety Inputs** can be moved anywhere within the left and middle areas.
- **Function** and **Logic blocks** can be moved anywhere within the middle area.

SC-XM2/3 button is unavailable (grayed out)

1. Make sure all connections are secure—SC-XMP2 to the USB port of the computer and to the SC-XM2 or SC-XM3 drive.
2. Verify that the SC-XMP2 Programming Tool is installed properly—see [Verifying Driver Installation](#) on page 333.
3. Exit the Software.
4. Disconnect and re-connect all connections—SC-XMP2 to the USB port of the computer and to the SC-XM2 or SC-XM3 drive.
5. Start the Software.



Note: Contact Banner Engineering if you require further assistance.

15.2 Software: Error Codes

The following table lists error codes that are encountered when attempting to make an invalid connection between blocks on the **Functional View** tab.



WARNING:

- **Configuration Conforms to Applicable Standards**
- Failure to verify the application may result in serious injury or death.
- The Banner Safety Controller Software primarily checks the logic configuration for connection errors. The user is responsible for verifying the application meets the risk assessment requirements and that it conforms to all applicable standards.

Software Code	Error
A.1	This connection creates a loop.
A.2	A connection from this block already exists.
A.3	Connecting a block to itself is not allowed.
B.2	This Bypass Block is connected to the TC node of a Two-Hand Control Block. You can connect only a Two-Hand Control input to the IN node of this Bypass Block.
B.3	This Bypass Block is already connected to another block.
B.4	This Bypass Block is connected to the TC node of a Two-Hand Control Block and cannot be connected to any other blocks.
B.5	Cannot connect Two-Hand Control Input to the IN node of this Bypass Block because it has the "Output turns OFF when both inputs (IN and BP) are ON" option disabled.
B.6	The IN node of a Bypass Block cannot be connected to Emergency Stop and Rope Pull inputs.
B.7	The IN node of a Bypass Block cannot be connected to Emergency Stop and Rope Pull inputs via other blocks.
C.1	Only a Cancel OFF-Delay input can be connected to the CD node.
C.2	A Cancel OFF-Delay input can be connected only to the CD node of a Safety Output, One Shot Function Block, or Delay Function Block.
D.1	This External Device Monitoring input is configured for a Dual-Channel 2 Terminal circuit and can be connected only to the EDM node of a Safety Output.
E.1	The Enabling Device Block output nodes (P or S) can be connected only to the IN node of a Safety Output.
E.2	The IN node of an Enabling Device Block cannot be connected to Emergency Stop and Rope Pull inputs.
E.3	The ED node of an Enabling Device Block can be connected only to an Enabling Device input.
E.4	The ED node of an Enabling Device Block cannot be connected to Emergency Stop and Rope Pull inputs via other blocks.
E.5	An Enabling Device Block that has a Two-Hand Control block connected to the IN node cannot be connected to a Safety Output that has <i>Safety Output Delay</i> set to "Off Delay".
F.1	Emergency Stop and Rope Pull inputs cannot be muted, and thus cannot be connected to the IN node of a Mute Function Block or the M Safety input of the Press Control Inputs Function Block.
F.2	Emergency Stop and Rope Pull inputs cannot be connected to a Latch Reset Block that is connected to a Muting Block.
F.3	A Latch Reset Block that is connected to an Emergency Stop or a Rope Pull input cannot be connected to a Muting Block.
G.1	XS/SC26 FID 1, 2, & 3 and SC10-2: Only a Manual Reset output can be connected to the FR node of a Safety Output. XS/SC26 FID 4 or later: Only a Manual Reset input or an output node of a Reset-Designated OR Block can be connected to the FR node of a Safety Output.
G.2	XS/SC26 FID 1, 2, & 3 and SC10-2: Only a Manual Reset input can be connected to the LR node of a Latch Reset Block or Safety Output. XS/SC26 FID 4 or later: Only a Manual Reset input or the output node of a Reset-Designated OR Block can be connected to the LR node of a Latch Reset Block or Safety Output.
G.3	XS/SC26 FID 1, 2, & 3 and SC10-2: Only a Manual Reset output can be connected to the RST node of an Enabling Device Block. XS/SC26 FID 4 or later: Only a Manual Reset input or an output node of a Reset-Designated OR Block can be connected to the RST node of an Enabling Device Block.

Software Code	Error
G.4	XS/SC26 FID 1, 2, & 3 and SC10-2: A Manual Reset input can be connected only to LR and FR nodes of a Safety Output, an LR node of a Latch Reset Block, an RST node of an Enabling Device Block, and SET and RST nodes of the Flip-Flop Blocks. XS/SC26 FID 4 or later: A Manual Reset input can be connected only to LR and FR nodes of a Safety Output, an LR node of a Latch Reset Block, an RST node of an Enabling Device Block, SET and RST nodes of the Flip-Flop Blocks, RST node of a Press Control Block, and an input node of a Reset-Designated OR Block.
G.5	The input node of a Reset-Designated OR Block can be connected only to a Manual Reset, Virtual Manual Reset input, and the output node of a Reset-Designated OR Block.
G.6	The output node of a Reset-Designated OR Block can be connected only to LR and FR nodes of a Safety Output, an LR node of a Latch Reset Block, an RST node of an Enabling Device Block, SET and RST nodes of the Flip-Flop Blocks, and an input node of a Reset-Designated OR Block.
H.1	A latch reset block already connected to a function block cannot connect to a Mute block.
H.2	A latch reset block already connected to a Mute block cannot connect to another function block.
I.1	Only Muting Sensor Pair, Optical Sensor, Gate Switch, Safety Mat, or Protective Stop inputs can be connected to the MP1 and MP2 nodes of a Muting Block or to the MP1 node of a Two-Hand Control Block.
I.2	The MP1 and MP2 nodes of a Muting Block and the MP1 node of a Two-Hand Control Block can be connected to inputs that are using only Dual-Channel circuits.
I.3	A Muting Sensor Pair input can be connected only to MP1 and MP2 nodes of a Muting Block or the MP1 node of a Two-Hand Control Block.
J.1	XS/SC26 FID 1, 2, & 3 and SC10-2 FID 1: A Two-Hand Control Block can be connected only to the IN node of an Enabling Device Block or the IN node of a Safety Output. XS/SC26 FID 4 or later or SC10-2 FID 2 or later: A Two-Hand Control Block can be connected only to a Logic Block (excluding Flip-Flop Blocks), the IN node of an Enabling Device Block, or the IN node of a Safety Output.
J.3	Only Two-Hand Control inputs or Bypass Blocks with Two-Hand Control inputs connected to them can be connected to the TC node of a Two-Hand Control Block. A Bypass Block with a Two-Hand Control input connected to its IN node can only be connected to the TC node of a Two-Hand Control Block.
K.1	XS/SC26 FID 1, 2, & 3 and SC10-2 FID 1: A Two-Hand Control input can be connected only to a Two-Hand Control Block (TC node) or Bypass Block (IN node). XS/SC26 FID 4 or later or SC10-2 FID 2 or later: A Two-Hand Control input can be connected only to a Two-Hand Control Block (TC node), Bypass Block (IN node), Logic Block (excluding Flip-Flop Blocks), Press Control Block (GO node), or an output without an OFF-delay.
K.2	XS/SC26 FID 1, 2, & 3 and SC10-2 FID 1: A Safety Output that has <i>Safety Output Delay</i> set to "OFF-Delay" cannot be connected to a Two-Hand Control Block. XS/SC26 FID 4 or later or SC10-2 FID 2 or later: A Safety Output that has <i>Safety Output Delay</i> set to "OFF-Delay" cannot be directly connected to a Two-Hand Control Block.
K.3	A Safety Output that has <i>Safety Output Delay</i> set to "OFF-Delay" cannot be connected to a Two-Hand Control Block via an Enabling Device Block.
L.1	This Safety Output is disabled because a Status Output is using its terminals.
L.2	The IN node of a Safety Output cannot be connected to External Device Monitoring, Adjustable Valve Monitor, Mute Sensor Pair, Bypass Switch, Manual Reset, Mute Enable, or Cancel OFF-Delay inputs.
L.3	A Safety Output block that has <i>LR (Latch Reset)</i> function enabled cannot be connected to Two-Hand Control Blocks or Enabling Device Blocks.
L.4	XS/SC26 FID 1, 2 & 3 and SC10-2 FID 1: A Safety Output block that has <i>Power up Mode</i> set to "Manual Reset" cannot be connected to Two-Hand Control Blocks or Enabling Device Blocks. XS/SC26 FID 4 or later or SC10-2 FID2 or later: A Safety Output block that has <i>Power up Mode</i> set to 'Manual Reset' cannot be connected to Two-Hand Control Inputs, Two-Hand Control Blocks, or Enabling Device Blocks.
P.1	Only physical or virtual ON/OFF inputs can be connected to the RUN , INCH UP , and INCH DOWN nodes of the Press Control Mode Function Block.
P.2	Only a physical ON/OFF Input can be connected to the TOS and BOS nodes of the Press Control Function Block, and the PIP node of the Press Control Inputs Function Block.
P.3	Only an SQS Input can be connected to the SQS Input node of the Press Control Input function block.
P.4	The only input that can be connected to the M Sensor input of the Press Control Input function block is a Press Control Mute Sensor input device.

Software Code	Error
P.5	When the Press Control block is configured for Single Actuator Control, the GO input node can only be connected to a Cycle Initiation input, a Foot Switch input, or a Two-Hand Control input. When the Press Control Block is configured for Manual Upstroke Setting, the GO input node can only be connected to a Foot Switch input or Two-Hand Control input.
P.6	If Single Actuator Control is selected in the Press Control Function Block, then Sequential Stop (SQS) and Manual Upstroke are not allowed.
P.7	Only a physical ON/OFF input or a Foot Switch input can be connected to the Ft Switch input of the Press Control Inputs Function Block.
P.8	The Press Control Function Block output nodes (U, D, H, and L) can be connected only to the IN node of a Safety Output.
P.9	When the Press Control Mute Sensor input is not selected, only a dual-channel SQS input can be connected to the SQS input node of the Press Control Input function block.

15.3 Verifying Driver Installation

This section applies to both the XS/SC26 and the SC10-2.

Safety Controller Drivers—Windows 7, 10, and 11

1. Open **Device Manager**.
2. Expand the **Ports (COM & LPT)** dropdown menu.
3. Find **XS26-2 Expandable Safety Controller** followed by a COM port number (for example, COM3). It must not have an exclamation mark, a red ×, or a down arrow on the entry. If you do not have any of these indicators, your device is properly installed. If any of the indicators appear, use the instructions below to resolve these issues.

Figure 323. XS/SC26 Safety Controller Drivers installed correctly

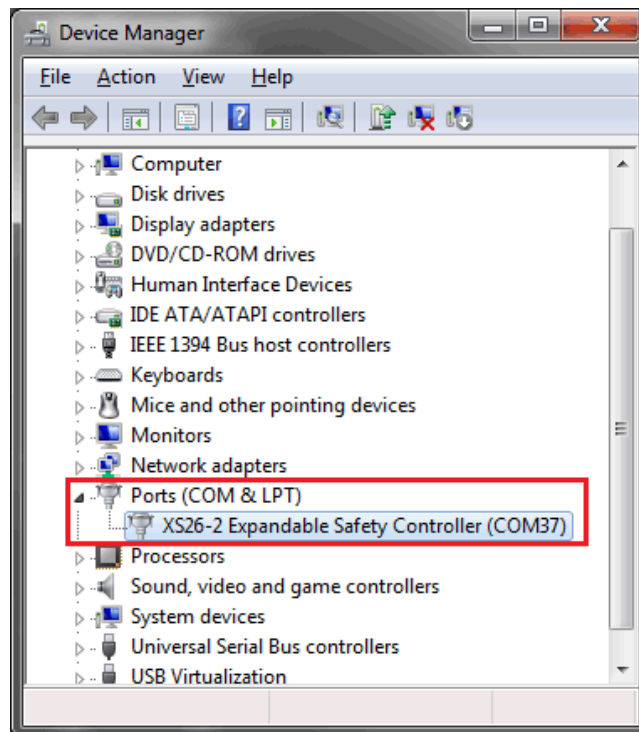

SC-XMP2 Drivers—Windows 7, 10, and 11

1. Open **Device Manager**.
2. Expand the **Universal Serial Bus controllers** dropdown menu.
3. Find **XMP2 Programmer A** and **XMP2 Programmer B**. Either one of the entries must not have an exclamation mark, a red ×, or a down arrow on the entry. If you do not have any of these indicators, your device is properly installed. If any of the indicators appear, use the instructions below to resolve these issues.

Figure 324. SC-XMP2 Drivers installed correctly

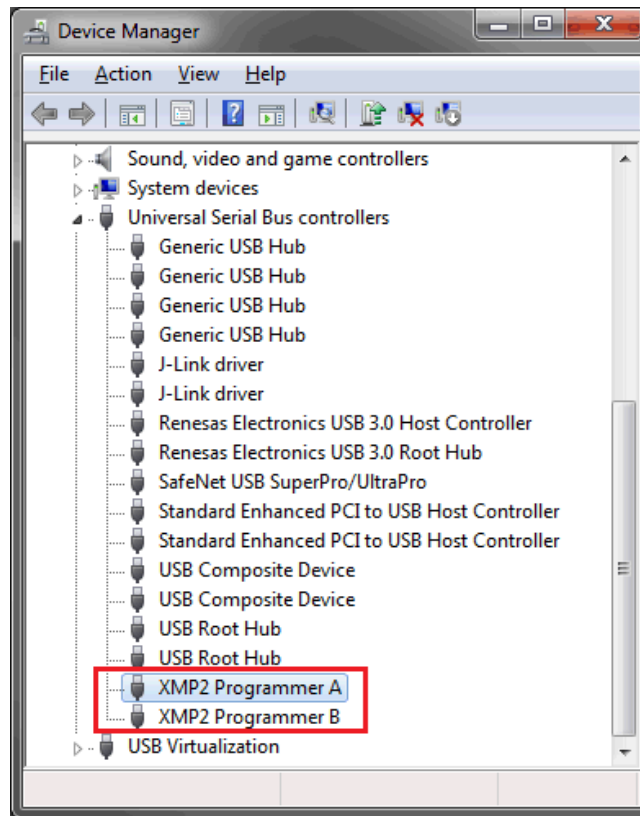

Resolve an Exclamation Mark, a Red x, or a Down Arrow Indicator

1. Make sure your device is enabled:
 - a. Right-click on the entry that has the indicator.
 - b. If you see **Disable**, the device is enabled; if you see **Enable**, the device is disabled.
 - If the device is enabled, continue with troubleshooting steps.
 - If the device is disabled, click **Enable**. If this does not remove the indicator, continue to the next step.
2. Unplug the USB cable either from the Safety Controller or from the computer, wait a few seconds and plug it back in. If this does not remove the indicator, continue to the next step.
3. Try plugging in the Safety Controller or SC-XMP2 to a different USB port. If this does not remove the indicator, continue to the next step.
4. Reboot your computer. If this does not remove the indicator, continue to the next step.
5. Uninstall and re-install the Software from **Add/Remove Programs** or **Programs and Features** located in the **Control Panel**. If this does not remove the indicator, continue to the next step.
6. Contact Banner Engineering.

Resolve the Safety Controller listed in Device Manager as 'Generic USB Device'

1. Right click on the Generic USB Device port that is the Banner Engineering Safety Controller.
2. Click **Update Driver**.
3. Select **Browse my Computer for Driver Software**.
4. Click the **Browse** box to the right of the **Search this Location** box. A new window opens.
5. Select **Local Disk (C:) > Program Files (x86) > Banner Engineering > Banner Safety Controller > Driver**.
6. Click **OK**; the window closes.
7. In the update driver box, click **Next**. The driver should now be updated.

You might have to close the Banner Safety Controller Software and open it again. The USB ports should now link Banner Engineering Safety Controllers to the Software.

15.4 Finding and Fixing Faults

Depending on the configuration, the Safety Controller is able to detect a number of input, output, and system faults, including:

- A stuck contact
- An open contact
- A short between channels
- A short to ground
- A short to a voltage source
- A short to another input
- A loose or open connection
- An exceeded operational time limit
- A power drop
- An overtemperature condition

When a fault is detected, a message describing the fault displays in the **Fault Diagnostics** menu (models with display). For models not equipped with a display, use the **Live Mode** tab in the Software on a PC connected to Safety Controller with the SC-USB2 cable. Fault diagnostics are also available over the network. An additional message may also be displayed to help remedy the fault.



Note: The fault log is cleared when power to the Safety Controller is cycled.

15.4.1 XS/SC26 Fault Code Table

The following table lists the Safety Controller Fault Code, the message that displays, any additional messages, as well as the steps to resolve the fault.

The Error Code and the Advanced Error Code, taken together, form the Safety Controller Fault Code. The format for the Fault Code is `Error Code 'dot' Advanced Error Code`. For example, a Safety Controller Fault Code of 2.1 is represented by an Error Code of 2 and an Advanced Error Code of 1. The Error Message Index value is the Error Code and the Advanced Error Code together, and includes a leading zero with the Advanced Error Code, if necessary. For example, a Safety Controller Fault Code of 2.1 is represented by an Error Message Index of 201. The Error Message Index value is a convenient way to get the complete Fault Code while only reading a single 16-bit register.



Note: An error code of 1.1 is different from an error code of 1.10 (the zero is significant).

Fault Code	Displayed Message	Additional Message	Steps to resolve
1.1	Output Fault	Base Controller or Solid-State Module Check for shorts Relay Module n/a	Base Controller or Solid-State Module A Safety Output appears ON when it should be OFF: <ul style="list-style-type: none"> • Check for a short to the external voltage source • Check the DC common wire size connected to the Safety Output loads. The wire must be a heavy-gauge wire or be as short as possible to minimize resistance and voltage drop. If necessary, use a separate DC common wire for each pair of outputs and/or avoid sharing this DC common return path with other devices (see Common Wire Installation on page 67) Relay Module <ul style="list-style-type: none"> • Replace Relay module
1.2	Output Fault	Base Controller or Solid-State Module Check for shorts Relay Module n/a	Base Controller or Solid-State Module A Safety Output is sensing a fault to another voltage source while the output is ON: <ul style="list-style-type: none"> • Check for a short between Safety Outputs • Check for a short to the external voltage source • Check load device compatibility • Check the DC common wire size connected to the Safety Output loads. The wire must be a heavy-gauge wire or be as short as possible to minimize resistance and voltage drop. If necessary, use a separate DC common wire for each pair of outputs and/or avoid sharing this DC common return path with other devices (see Common Wire Installation on page 67) Relay Module <ul style="list-style-type: none"> • Replace Relay module
1.3 – 1.8	Internal Fault	-	Internal failure—Contact Banner Engineering (see Repairs and Warranty Service on page 344)
1.9	Output Fault	Internal Relay Failure	<ul style="list-style-type: none"> • Replace Relay module
1.10	Output Fault	Check Input Timing	Sequence timing error: <ul style="list-style-type: none"> • Perform a System Reset to clear the fault

Fault Code	Displayed Message	Additional Message	Steps to resolve
2.1	Concurrency Fault	Cycle Input	<p>On a dual-channel input, or a complementary input, with both inputs in the Run state, one input went to the Stop state then back to Run.</p> <p>On a dual-complementary input, with both pairs of inputs in the Run state, one pair of inputs went to the Stop state then back to Run.</p> <ul style="list-style-type: none"> • Check the wiring • Check the input signals • Consider adjusting the debounce times
2.2	Simultaneity Fault	Cycle Input	<p>On a dual-channel input, or a complementary input, one input went into the Run state but the other input did not follow the change within 3 seconds.</p> <p>On a dual-complementary input, one pair of inputs went into the Run state but the other pair of inputs did not follow the change within 3 seconds.</p> <ul style="list-style-type: none"> • Check the wiring • Check the input signal timing
2.3 or 2.5	Concurrency Fault	Cycle Input	<p>On a dual-complementary input, with both inputs of one complementary pair in the Run state, one input of this complementary pair changed to Stop then back to Run:</p> <ul style="list-style-type: none"> • Check the wiring • Check the input signals • Check the power supply providing input signals • Consider adjusting the debounce times
2.4 or 2.6	Simultaneity Fault	Cycle Input	<p>On a dual-complementary input, one input of a complementary pair went into the Run state, but the other input of the same complementary pair did not follow the change within the time limit:</p> <ul style="list-style-type: none"> • Check the wiring • Check the input signal timing
2.7	Internal Fault		Internal failure—Contact Banner Engineering (see Repairs and Warranty Service on page 344)
2.8 – 2.9	Input Fault	Check Terminal xx	<p>Input stuck high:</p> <ul style="list-style-type: none"> • Check for shorts to other inputs or other voltage sources • Check the input device compatibility • Check for miss wired terminals (output terminal wired to wrong input terminal)
2.10	Input Fault	Check Terminal xx	<ul style="list-style-type: none"> • Check for a short between inputs
2.11 – 2.12	Input Fault	Check Terminal xx	<ul style="list-style-type: none"> • Check for a short to ground
2.13	Input Fault	Check Terminal xx	<p>Input stuck low</p> <ul style="list-style-type: none"> • Check for a short to ground
2.14	Input Fault	Check Terminal xx	<p>Missing test pulses:</p> <ul style="list-style-type: none"> • Check for a short to other inputs or other voltage sources
2.15	Open Lead	Check Terminal xx	<ul style="list-style-type: none"> • Check for an open lead
2.16 – 2.18	Input Fault	Check Terminal xx	<p>Missing test pulses:</p> <ul style="list-style-type: none"> • Check for a short to other inputs or other voltage sources
2.19	Open Lead	Check Terminal xx	<ul style="list-style-type: none"> • Check for an open lead
2.20	Input Fault	Check Terminal xx	<p>Missing test pulses:</p> <ul style="list-style-type: none"> • Check for a short to ground
2.21	Open Lead	Check Terminal xx	<ul style="list-style-type: none"> • Check for an open lead
2.22 – 2.23	Input Fault	Check Terminal xx	<ul style="list-style-type: none"> • Check for an unstable signal on the input
2.24	Input Activated While Bypassed	Perform System Reset	A Two-Hand Control input was activated (turned ON) while it was bypassed.

Fault Code	Displayed Message	Additional Message	Steps to resolve
2.25	Input Fault	Monitoring Timer Expired Before AVM Closed	After the associated Safety Output turned OFF, the AVM input did not close before its AVM monitoring time expired: <ul style="list-style-type: none"> The AVM may be disconnected; check the wiring to the AVM Either the AVM is disconnected, or its response to the Safety Output turning OFF is too slow Check the wiring to the AVM Check the timing setting; increase the setting if necessary Contact Banner Engineering
2.26	Input Fault	AVM Not Closed When Output Turned On	The AVM input was open, but should have been closed, when the associated Safety Output was commanded ON: <ul style="list-style-type: none"> The AVM may be disconnected; check the wiring to the AVM
3.1	EDMxx Fault	Check Terminal xx	EDM contact opened prior to turning ON the Safety Outputs: <ul style="list-style-type: none"> Check for a stuck ON contactor or relay Check for an open wire
3.2	EDMxx Fault	Check Terminal xx	EDM contact(s) failed to close within 250 ms after the Safety Outputs turned OFF: <ul style="list-style-type: none"> Check for a slow or stuck ON contactor or relay Check for an open wire
3.4	EDMxx Fault	Check Terminal xx	EDM contact pair mismatched for longer than 250 ms: <ul style="list-style-type: none"> Check for a slow or stuck ON contactor or relay Check for an open wire
3.5	EDMxx Fault	Check Terminal xx	<ul style="list-style-type: none"> Check for an unstable signal on the input
3.6	EDMxx Fault	Check Terminal xx	<ul style="list-style-type: none"> Check for a short to ground
3.7	EDMxx Fault	Check Terminal xx	<ul style="list-style-type: none"> Check for a short between inputs
3.8	AVMxx Fault	Perform System Reset	After this Safety Output turned OFF, an AVM input associated with this output did not close before its AVM monitoring time expired: <ul style="list-style-type: none"> The AVM may be disconnected or its response to the Safety Output turning OFF may be too slow Check the AVM input and then perform a System Reset to clear the fault
3.9	Input Fault	AVM Not Closed When Output Turned On	The AVM input was open, but should have been closed, when the associated Safety Output was commanded On: <ul style="list-style-type: none"> The AVM may be disconnected; check the wiring to the AVM
3.10	Internal Fault	-	Internal failure—Contact Banner Engineering (see Repairs and Warranty Service on page 344)
4.x	-	-	See the following table.
5.1 – 5.3	Internal Fault	-	Internal failure—Contact Banner Engineering (see Repairs and Warranty Service on page 344)
6.xx	Internal Fault	-	Invalid configuration data. Possible internal failure: <ul style="list-style-type: none"> Try writing a new configuration to the Safety Controller
7.1	Press Control Fault	Check TOS and BOS	TOS and BOS inputs on at the same time <ul style="list-style-type: none"> Check for shorts on the TOS and BOS inputs Check for functional issues with the TOS and BOS devices
7.2	Press Control Fault	Check TOS and SQS	TOS and SQS inputs on at the same time <ul style="list-style-type: none"> Check for shorts on the TOS and SQS inputs Check for functional issues with the TOS and SQS devices
7.3	Press Control Fault	Check TOS and PCMS	TOS and PCMS inputs on at the same time <ul style="list-style-type: none"> Check for shorts on the TOS and PCMS inputs Check for functional issues with the TOS and PCMS devices
7.4	Press Control Fault	Check SQS and BOS	SQS to BOS sequencing error (BOS came on before SQS) <ul style="list-style-type: none"> Check wiring of SQS and BOS sensors Check for placement and functional issues of SQS and BOS sensors

Fault Code	Displayed Message	Additional Message	Steps to resolve
7.5	Press Control Fault	Check TOS	TOS Timeout error (On automatic upstroke, the internal 30 second time limit was exceeded) <ul style="list-style-type: none"> Check the wiring of the TOS system Check for placement and functional issues of the TOS sensor
7.6	Press Control Fault	Check BOS	BOS Timeout error (On automatic downstroke, the internal 30 second time limit was exceeded) <ul style="list-style-type: none"> Check the wiring of the BOS system Check for placement and functional issues of the BOS sensor
7.7	Press Control Fault	Check Mode Selection Inputs	Mode Selection Error (more than one mode selection input on at the same time) <ul style="list-style-type: none"> Check the wiring from the mode state inputs Check the Mode selection switch for faults
7.8	Press Control Fault	-	Index Error (Internal Configuration Error) Contact Banner Engineering (see Repairs and Warranty Service on page 344)
7.9	Press Control Fault	Check Foot Switch Input	Foot switch Error (when configured with a SQS, the Ft Switch input node came on instead of the GO input node) <ul style="list-style-type: none"> Sequencing error If it persists check wiring of THC and Foot Switch inputs
7.10	Press Control Fault	Check Down Cylinder	Down AVM Error (Down AVM is in wrong state when compared to expected state) <ul style="list-style-type: none"> Check Down AVM wiring Check Down AVM sensor and Down Stroke system
7.11	Press Control Fault	Check Up Cylinder	Up AVM Error (Up AVM is in wrong state when compared to expected state) <ul style="list-style-type: none"> Check Up AVM wiring Check Up AVM sensor and Up Stroke system
7.12	Press Control Fault	Check High Cylinder	High AVM Error (High AVM is in wrong state when compared to expected state) <ul style="list-style-type: none"> Check High AVM wiring Check High AVM sensor and High Stroke system
7.13	Press Control Fault	Check Low Cylinder	Low AVM Error (Low AVM is in wrong state when compared to expected state) <ul style="list-style-type: none"> Check Low AVM wiring Check Low AVM sensor and Low Stroke system
7.14	Press Control Fault	SQS to PCMS Simultaneity	SQS to PCMS simultaneity error (3 second time limit between inputs exceeded) <ul style="list-style-type: none"> Check wiring of SQS and PCMS Check placement of SQS and PCMS with considerations to ram speed
7.15	Press Control Fault	Check SQS State	SQS State error (SQS state level not as expected during the press cycle) <ul style="list-style-type: none"> Check wiring of the SQS input Check the placement of the SQS sensor and its functionality
7.16	Press Control Fault	Check PCMS State	PCMS State error (PCMS state level not as expected during the press cycle) <ul style="list-style-type: none"> Check wiring of the PCMS input Check the placement of the PCMS sensor and its functionality
7.17	Press Control Fault	Check TOS State	TOS State error (TOS state level not as expected during the press cycle) <ul style="list-style-type: none"> Check wiring of the TOS input Check the placement of the TOS sensor and its functionality
7.18	Press Control Fault	Check BOS State	BOS State error (BOS state level not as expected during the press cycle) <ul style="list-style-type: none"> Check wiring of the BOS input Check the placement of the BOS sensor and its functionality
10.xx	Internal Fault	-	Internal failure—Contact Banner Engineering (see Repairs and Warranty Service on page 344)

For fault codes 4.x, check the fault log for additional faults to determine the specific module in which the original fault occurred.

Fault Code	Displayed Message	Additional Message	Steps to resolve
4.1	Supply Voltage Low	Check the power supply	The supply voltage dropped below the rated voltage for longer than 6 ms: <ul style="list-style-type: none"> Check the power supply voltage and current rating Check for an overload on the outputs that might cause the power supply to limit the current
4.2	Internal Fault		A configuration parameter has become corrupt. To fix the configuration: <ul style="list-style-type: none"> Replace the configuration by using a backup copy of the configuration Recreate the configuration using the Software and write it to the Safety Controller
4.3 – 4.11	Internal Fault	-	Internal failure—Contact Banner Engineering (see Repairs and Warranty Service on page 344).
4.12	Configuration Timeout	Check Configuration	The Safety Controller was left in Configuration mode for more than one hour without pressing any keys. <ul style="list-style-type: none"> Cycle the power Perform a System Reset
4.13	Configuration Timeout	Check Configuration	The Safety Controller was left in Configuration mode for more than one hour without receiving any commands from the Software. <ul style="list-style-type: none"> Cycle the power Perform a System Reset
4.14	Configuration Unconfirmed	Confirm Configuration	The configuration was not confirmed after being edited: <ul style="list-style-type: none"> Confirm configuration using the Software
4.15 – 4.19	Internal Fault	-	Internal failure—Contact Banner Engineering (see Repairs and Warranty Service on page 344).
4.20	Unassigned Terminal in Use	Check Terminal xx	This terminal is not mapped to any device in the present configuration and should not be active: <ul style="list-style-type: none"> Check the wiring
4.21 – 4.34	Internal Fault	-	Internal failure—Contact Banner Engineering (see Repairs and Warranty Service on page 344).
4.35	Overtemperature	-	An internal overtemperature condition has occurred. Verify that the ambient and output loading conditions meet the specifications of the Safety Controller.
4.36 – 4.39	Internal Fault	-	Internal failure—Contact Banner Engineering (see Repairs and Warranty Service on page 344).
4.40 – 4.41	Module Communication Failure	Check module power	An output expansion module lost contact with the Base Controller.
4.42	Module Mismatch	-	The module or modules detected do not match the Safety Controller configuration.
4.43	Module Communication Failure	Check module power	An expansion module lost contact with the Base Controller.
4.44 – 4.45	Internal Fault	-	Internal failure—Contact Banner Engineering (see Repairs and Warranty Service on page 344).
4.46 – 4.47	Internal Fault	-	Internal failure—Contact Banner Engineering (see Repairs and Warranty Service on page 344).
4.48	Unused output	Check output wiring	A voltage was detected on an unconfirmed terminal.
4.49 – 4.55	Internal Fault	-	Internal failure—Contact Banner Engineering (see Repairs and Warranty Service on page 344).
4.56	Display Comm Failure	-	Display (Onboard Interface) Communication Failure: <ul style="list-style-type: none"> Cycle power to the Safety Controller. If fault code persists, contact Banner Engineering (see Repairs and Warranty Service on page 344)
4.57 – 4.59	Internal Fault	-	Internal failure—Contact Banner Engineering (see Repairs and Warranty Service on page 344).
4.60	Output Fault	Check for shorts	An output terminal detected a short. Check output fault for details.

Fault Code	Displayed Message	Additional Message	Steps to resolve
4.61	Config Mismatch	-	<p>A feature (for example, ISD inputs, virtual inputs, expansion modules) contained in the loaded configuration is not supported by this controller model. The configuration is now confirmed and can be saved as a confirmed configuration and/or written to an SC-XM2/3. The configuration will not run on this model.</p> <ul style="list-style-type: none"> Remove the features not supported by this model Load the configuration on a model that supports the selected features

15.4.2 SC10-2 Fault Code Table

The following table lists the Safety Controller Fault Code, the message that displays, any additional messages, as well as the steps to resolve the fault.

The Error Code and the Advanced Error Code, taken together, form the Safety Controller Fault Code. The format for the Fault Code is Error Code 'dot' Advanced Error Code. For example, a Safety Controller Fault Code of 2.1 is represented by an Error Code of 2 and an Advanced Error Code of 1. The Error Message Index value is the Error Code and the Advanced Error Code together, and includes a leading zero with the Advanced Error Code, if necessary. For example, a Safety Controller Fault Code of 2.1 is represented by an Error Message Index of 201. The Error Message Index value is a convenient way to get the complete Fault Code while only reading a single 16-bit register.



Note: An error code of 1.1 is different from an error code of 1.10 (the zero is significant).

Fault Code	Fault Code Description	Steps to resolve
1.1 – 1.2	Output Fault	Replace the Safety Controller
1.3 – 1.8	Internal Fault	Internal failure—Contact Banner Engineering (see Repairs and Warranty Service on page 344)
1.9	Output Fault	Replace the Safety Controller
1.10	Output Fault	<p>Sequence timing error:</p> <ul style="list-style-type: none"> Perform a System Reset to clear the fault
2.1	Concurrency Fault	<p>On a dual-channel input, or a complementary input, with both inputs in the Run state, one input went to the Stop state then back to Run.</p> <p>On a dual-complementary input, with both pairs of inputs in the Run state, one pair of inputs went to the Stop state then back to Run.</p> <ul style="list-style-type: none"> Check the wiring Check the input signals Consider adjusting the debounce times Cycle input
2.2	Simultaneity Fault	<p>On a dual-channel input, or a complementary input, one input went into the Run state but the other input did not follow the change within 3 seconds.</p> <p>On a dual-complementary input, one pair of inputs went into the Run state but the other pair of inputs did not follow the change within 3 seconds.</p> <ul style="list-style-type: none"> Check the wiring Check the input signal timing Cycle input
2.3 or 2.5	Concurrency Fault	<p>On a dual-complementary input, with both inputs of one complementary pair in the Run state, one input of this complementary pair changed to Stop then back to Run.:</p> <ul style="list-style-type: none"> Check the wiring Check the input signals Check the power supply providing input signals Consider adjusting the debounce times Cycle input
2.4 or 2.6	Simultaneity Fault	<p>On a dual-complementary input, one input of a complementary pair went into the Run state, but the other input of the same complementary pair did not follow the change within the time limit:</p> <ul style="list-style-type: none"> Check the wiring Check the input signal timing Cycle input
2.7	Internal Fault	Internal failure—Contact Banner Engineering (see Repairs and Warranty Service on page 344)

Fault Code	Fault Code Description	Steps to resolve
2.8 – 2.9	Input Fault	Input stuck high: <ul style="list-style-type: none"> • Check for shorts to other inputs or other voltage sources • Check the input device compatibility • Check for miss wired terminals (output terminal wired to wrong input terminal)
2.10	Input Fault	<ul style="list-style-type: none"> • Check for a short between inputs
2.11 – 2.12	Input Fault	<ul style="list-style-type: none"> • Check for a short to ground
2.13	Input Fault	Input stuck low <ul style="list-style-type: none"> • Check for a short to ground
2.14	Input Fault	Missing test pulses: <ul style="list-style-type: none"> • Check for a short to other inputs or other voltage sources
2.15	Open Lead	<ul style="list-style-type: none"> • Check for an open lead
2.16 – 2.18	Input Fault	Missing test pulses: <ul style="list-style-type: none"> • Check for a short to other inputs or other voltage sources
2.19	Open Lead	<ul style="list-style-type: none"> • Check for an open lead
2.20	Input Fault	Missing test pulses: <ul style="list-style-type: none"> • Check for a short to ground
2.21	Open Lead	<ul style="list-style-type: none"> • Check for an open lead
2.22 – 2.23	Input Fault	<ul style="list-style-type: none"> • Check for an unstable signal on the input
2.24	Input Activated While Bypassed	A Two-Hand Control input was activated (turned On) while it was bypassed.
2.25	Input Fault	After the associated Safety Output turned Off, the AVM input did not close before its AVM monitoring time expired: <ul style="list-style-type: none"> • The AVM may be disconnected; check the wiring to the AVM • Either the AVM is disconnected, or its response to the Safety Output turning Off is too slow • Check the wiring to the AVM • Check the timing setting; increase the setting if necessary • Contact Banner Engineering
2.26	Input Fault	The AVM input was open, but should have been closed, when the associated Safety Output was commanded On: <ul style="list-style-type: none"> • The AVM may be disconnected; check the wiring to the AVM
3.1	EDMxx Fault	EDM contact opened prior to turning On the Safety Outputs: <ul style="list-style-type: none"> • Check for a stuck On contactor or relay • Check for an open wire
3.2	EDMxx Fault	EDM contact(s) failed to close within 250 ms after the Safety Outputs turned Off: <ul style="list-style-type: none"> • Check for a slow or stuck On contactor or relay • Check for an open wire
3.4	EDMxx Fault	EDM contact pair mismatched for longer than 250 ms: <ul style="list-style-type: none"> • Check for a slow or stuck On contactor or relay • Check for an open wire
3.5	EDMxx Fault	<ul style="list-style-type: none"> • Check for an unstable signal on the input
3.6	EDMxx Fault	<ul style="list-style-type: none"> • Check for a short to ground
3.7	EDMxx Fault	<ul style="list-style-type: none"> • Check for a short between inputs
3.8	AVMxx Fault	After this Safety Output turned Off, an AVM input associated with this output did not close before its AVM monitoring time expired: <ul style="list-style-type: none"> • The AVM may be disconnected or its response to the Safety Output turning Off may be too slow • Check the AVM input and then perform a System Reset to clear the fault

Fault Code	Fault Code Description	Steps to resolve
3.9	Input Fault	The AVM input was open, but should have been closed, when the associated Safety Output was commanded On: <ul style="list-style-type: none"> The AVM may be disconnected; check the wiring to the AVM
3.10	Internal Fault	Internal failure—Contact Banner Engineering (see Repairs and Warranty Service on page 344).
4.1	Supply Voltage Low	The supply voltage dropped below the rated voltage for longer than 6 ms: <ul style="list-style-type: none"> Check the power supply voltage and current rating Check for an overload on the outputs that might cause the power supply to limit the current
4.2	Internal Fault	A configuration parameter has become corrupt. To fix the configuration: <ul style="list-style-type: none"> Replace the configuration by using a backup copy of the configuration Recreate the configuration using the Software and write it to the Safety Controller
4.3 – 4.12	Internal Fault	Internal failure—Contact Banner Engineering (see Repairs and Warranty Service on page 344).
4.13	Configuration Timeout	The Safety Controller was left in Configuration mode for more than one hour without receiving any commands from the Software. <ul style="list-style-type: none"> Cycle the power Perform a System Reset
4.14	Configuration Unconfirmed	The configuration was not confirmed after being edited: <ul style="list-style-type: none"> Confirm configuration using the Software
4.15 – 4.19	Internal Fault	Internal failure—Contact Banner Engineering (see Repairs and Warranty Service on page 344).
4.20	Unassigned Terminal in Use	This terminal is not mapped to any device in the present configuration and should not be active: <ul style="list-style-type: none"> Check the wiring
4.21 – 4.34	Internal Fault	Internal failure—Contact Banner Engineering (see Repairs and Warranty Service on page 344).
4.35	Overtemperature	An internal overtemperature condition has occurred. Verify that the ambient and output loading conditions meet the specifications of the Safety Controller.
4.36 – 4.47	Internal Fault	Internal failure—Contact Banner Engineering (see Repairs and Warranty Service on page 344).
4.48	Unused output	A voltage was detected on an unconfirmed terminal.
4.49 – 4.59	Internal Fault	Internal failure—Contact Banner Engineering (see Repairs and Warranty Service on page 344).
4.60	Output Fault	An output terminal detected a short. Check output fault for details.
5.1 – 5.3	Internal Fault	Internal failure—Contact Banner Engineering (see Repairs and Warranty Service on page 344).
6.xx	Internal Fault	Invalid configuration data. Possible internal failure: <ul style="list-style-type: none"> Try writing a new configuration to the Safety Controller
10.xx	Internal Fault	Internal failure—Contact Banner Engineering (see Repairs and Warranty Service on page 344).

16 Components and Accessories

16.1 Replacement Parts and Accessories

Model	Description	Applicable Product
SC-USB2	USB cable	XS/SC26, SC10-2
SC-XMP2	Programming tool for SC-XM2/3	XS/SC26, SC10-2
DIN-SC	DIN End Clamp	XS/SC26, SC10-2
SC-XM2	External memory drive for the XS/SC26	XS/SC26
SC-XM3	External memory drive for the SC10-2	XS/SC26, SC10-2
SC-TS2	Screw terminal blocks controller	XS/SC26
SC-TS3	Screw terminal blocks expansion module	XS/SC26
SC-TC2	Spring cage terminal blocks controller	XS/SC26
SC-TC3	Spring cage terminal blocks expansion module	XS/SC26

16.2 Ethernet Cordsets

Cat5e Shielded Cordsets	Cat5e Crossover Shielded Cordsets	Length
STP07	STPX07	2.1 m (7 ft)
STP25	STPX25	7.62 m (25 ft)
STP50	STPX50	15.2 m (50 ft)
STP75	STPX75	22.9 m (75 ft)

16.3 Interface Modules

See datasheet p/n 62822 and p/n 208873 and [EDM and FSD Wiring](#) on page 70 for more information.

Model	Input Voltage	Inputs	Safety Outputs	Aux. Outputs	Output Rating	EDM Contacts
IM-T-9A	24 V dc	2 (dual-channel hookup)	3 N.O.	—	6 amps	2 N.C.
IM-T-11A			2 N.O.	1 N.C.		
SR-IM-9A			3 N.O.	—	See datasheet for specifications	
SR-IM-11A			2 N.O.	1 N.C.		

16.3.1 Mechanically Linked Contactors

Mechanically Linked Contactors provide an additional 10 or 18 amp carrying capability to any safety system. If used, two contactors per Safety Output pair are required for Category 4. A single output signal switching device (OSSD) output with 2 contactors can achieve Category 3. The N.C. contacts are to be used in an external device monitoring (EDM) circuit.

See [EDM and FSD Wiring](#) on page 70 for more information.

Model	Supply Voltage	Inputs	Outputs	Output Rating
11-BG00-31-D-024	24 V dc	2 (dual-channel hookup)	3 N.O. and 1 N.C.	10 amps
BF1801L-024				18 amps

17 Product Support and Maintenance

17.1 Cleaning

1. **Disconnect power to the Safety Controller.**
2. Wipe down the polycarbonate enclosure and the display (models with display) with a soft cloth that has been dampened with a mild detergent and warm water solution.

17.2 Repairs and Warranty Service

Contact Banner Engineering for troubleshooting of this device. **Do not attempt any repairs to this Banner device; it contains no field-replaceable parts or components.** If the device, device part, or device component is determined to be defective by a Banner Applications Engineer, they will advise you of Banner's RMA (Return Merchandise Authorization) procedure.



Important: If instructed to return the device, pack it with care. Damage that occurs in return shipping is not covered by warranty.

To assist Banner Engineering with troubleshooting a problem, while the PC is connected to the Safety Controller, go to Help in the software and click Support Information. Click **Save Controller Diagnostics** (located at **Help > Support Information**) to generate a file that contains status information. This information may be helpful to the support team at Banner. Send the file to Banner according to the instructions provided on screen.

17.3 Contact Us

Banner Engineering Corp. headquarters is located at:

9714 Tenth Avenue North
Minneapolis, MN 55441, USA
Phone: + 1 888 373 6767

For worldwide locations and local representatives, visit www.bannerengineering.com.

17.4 Banner Engineering Corp. Limited Warranty

Banner Engineering Corp. warrants its products to be free from defects in material and workmanship for one year following the date of shipment. Banner Engineering Corp. will repair or replace, free of charge, any product of its manufacture which, at the time it is returned to the factory, is found to have been defective during the warranty period. This warranty does not cover damage or liability for misuse, abuse, or the improper application or installation of the Banner product.

THIS LIMITED WARRANTY IS EXCLUSIVE AND IN LIEU OF ALL OTHER WARRANTIES WHETHER EXPRESS OR IMPLIED (INCLUDING, WITHOUT LIMITATION, ANY WARRANTY OF MERCHANTABILITY OR FITNESS FOR A PARTICULAR PURPOSE), AND WHETHER ARISING UNDER COURSE OF PERFORMANCE, COURSE OF DEALING OR TRADE USAGE.

This Warranty is exclusive and limited to repair or, at the discretion of Banner Engineering Corp., replacement. **IN NO EVENT SHALL BANNER ENGINEERING CORP. BE LIABLE TO BUYER OR ANY OTHER PERSON OR ENTITY FOR ANY EXTRA COSTS, EXPENSES, LOSSES, LOSS OF PROFITS, OR ANY INCIDENTAL, CONSEQUENTIAL OR SPECIAL DAMAGES RESULTING FROM ANY PRODUCT DEFECT OR FROM THE USE OR INABILITY TO USE THE PRODUCT, WHETHER ARISING IN CONTRACT OR WARRANTY, STATUTE, TORT, STRICT LIABILITY, NEGLIGENCE, OR OTHERWISE.**

Banner Engineering Corp. reserves the right to change, modify or improve the design of the product without assuming any obligations or liabilities relating to any product previously manufactured by Banner Engineering Corp. Any misuse, abuse, or improper application or installation of this product or use of the product for personal protection applications when the product is identified as not intended for such purposes will void the product warranty. Any modifications to this product without prior express approval by Banner Engineering Corp will void the product warranties. All specifications published in this document are subject to change; Banner reserves the right to modify product specifications or update documentation at any time. Specifications and product information in English supersede that which is provided in any other language. For the most recent version of any documentation, refer to: www.bannerengineering.com.

For patent information, see www.bannerengineering.com/patents.

17.5 Banner Engineering Corp. Software Copyright Notice

© Banner Engineering Corp., All Rights Reserved.

<https://www.bannerengineering.com/us/en/company/terms-and-conditions.html>

Disclaimer of Warranties. This software is provided "AS-IS." To the maximum extent permitted by applicable law, Banner, its affiliates, and its channel partners disclaim all warranties, expressed or implied, including any warranty that the software is fit for a particular purpose, title, merchantability, data loss, non-interference with or non-infringement of any intellectual property rights, or the accuracy, reliability, quality or content in or linked to the services. Banner and its affiliates and channel partners do not warrant that the services are secure, free from bugs, viruses, interruption, errors, theft or destruction. If the exclusions for implied warranties do not apply to you, any implied warranties are limited to 60 days from the date of first use of this software.

Limitation of Liability and Indemnity. Banner, its affiliates and channel partners are not liable for indirect, special, incidental, punitive or consequential damages, damages relating to corruption, security, loss or theft of data, viruses, spyware, loss of business, revenue, profits, or investment, or use of software or hardware that does not meet Banner minimum systems requirements. The above limitations apply even if Banner and its affiliates and channel partners have been advised of the possibility of such damages. This Agreement sets forth the entire liability of Banner, its affiliates and your exclusive remedy with respect to the software use.

18 Standards and Regulations

The list of standards below is included as a convenience for users of this Banner device. Inclusion of the standards below does not imply that the device complies specifically with any standard, other than those specified in the Specifications section of this manual.

18.1 Applicable U.S. Standards

ANSI B11.0 Safety of Machinery, General Requirements, and Risk Assessment
 ANSI B11.1 Mechanical Power Presses
 ANSI B11.2 Hydraulic Power Presses
 ANSI B11.3 Power Press Brakes
 ANSI B11.4 Shears
 ANSI B11.5 Iron Workers
 ANSI B11.6 Lathes
 ANSI B11.7 Cold Headers and Cold Formers
 ANSI B11.8 Drilling, Milling, and Boring
 ANSI B11.9 Grinding Machines
 ANSI B11.10 Metal Sawing Machines
 ANSI B11.11 Gear Cutting Machines
 ANSI B11.12 Roll Forming and Roll Bending Machines
 ANSI B11.13 Single- and Multiple-Spindle Automatic Bar and Chucking Machines
 ANSI B11.14 Coil Slitting Machines
 ANSI B11.15 Pipe, Tube, and Shape Bending Machines
 ANSI B11.16 Metal Powder Compacting Presses
 ANSI B11.17 Horizontal Extrusion Presses
 ANSI B11.18 Machinery and Machine Systems for the Processing of Coiled Strip, Sheet, and Plate
 ANSI B11.19 Performance Criteria for Safeguarding
 ANSI B11.20 Manufacturing Systems
 ANSI B11.21 Machine Tools Using Lasers
 ANSI B11.22 Numerically Controlled Turning Machines
 ANSI B11.23 Machining Centers
 ANSI B11.24 Transfer Machines
 ANSI/RIA R15.06 Safety Requirements for Industrial Robots and Robot Systems
 NFPA 79 Electrical Standard for Industrial Machinery
 ANSI/PMMI B155.1 Package Machinery and Packaging-Related Converting Machinery — Safety Requirements

18.2 Applicable OSHA Regulations

OSHA Documents listed are part of: Code of Federal Regulations Title 29, Parts 1900 to 1910
 OSHA 29 CFR 1910.212 General Requirements for (Guarding of) All Machines
 OSHA 29 CFR 1910.147 The Control of Hazardous Energy (lockout/tagout)
 OSHA 29 CFR 1910.217 (Guarding of) Mechanical Power Presses

18.3 Applicable European and International Standards

EN ISO 12100 Safety of Machinery – General Principles for Design — Risk Assessment and Risk Reduction
 ISO 13857 Safety of Machinery – Safety Distances to Prevent Hazard Zones Being Reached
 ISO 13850 (EN 418) Emergency Stop Devices, Functional Aspects – Principles for Design
 ISO 13851 Two-Hand Control Devices – Principles for Design and Selection
 IEC 62061 Functional Safety of Safety-Related Electrical, Electronic and Programmable Control Systems
 EN ISO 13849-1:2015 Safety-Related Parts of Control Systems

EN 13855 (EN 999) The Positioning of Protective Equipment in Respect to Approach Speeds of Parts of the Human Body
ISO 14119 (EN 1088) Interlocking Devices Associated with Guards – Principles for Design and Selection
EN 60204-1 Electrical Equipment of Machines Part 1: General Requirements
IEC 61496 Electro-sensitive Protection Equipment
IEC 60529 Degrees of Protection Provided by Enclosures
IEC 60947-1 Low Voltage Switchgear – General Rules
IEC 60947-5-1 Low Voltage Switchgear – Electromechanical Control Circuit Devices
IEC 60947-5-5 Low Voltage Switchgear – Electrical Emergency Stop Device with Mechanical Latching Function
IEC 61508 Functional Safety of Electrical/Electronic/Programmable Electronic Safety-Related Systems
IEC 62046 Safety of Machinery – Applications of Protective Equipment to Detect the Presence of Persons
ISO 16092-1 Machine Tool Safety—Presses, Part 1 Generic Safety Requirements
ISO 16092-3 Machine Tool Safety—Presses, Part 3 Safety Requirements for Hydraulic Presses
ISO 16092-4 Machine Tool Safety—Presses, Part 4 Safety Requirements for Pneumatic Presses
ISO 4413 Hydraulic Fluid Power—General Rules and Safety Requirements for Systems and their Components
ISO 4414 Pneumatic Fluid Power—General Rules and Safety Requirements for Systems and their Components

19 Glossary

A

Automatic Reset

The safety input device control operation setting where the assigned safety output will automatically turn on when all of its associated input devices are in the Run state.

C

Change of State (COS)

The change of an input signal when it switches from Run-to-Stop or Stop-to-Run state.

Closed-Open Debounce Time

Time to bridge a jittery input signal or bouncing of input contacts to prevent nuisance tripping of the Controller. Adjustable from 6 ms to 100 ms. The default value is 6 ms (50 ms for mute sensors).

Complementary Contacts

Two sets of contacts which are always in opposite states.

Concurrent (also Concurrency)

The setting in which both channels must be off at the same time before turning back on. If this is not satisfied, the input will be in a fault condition.

D

Designated Person

A person or persons identified and designated in writing, by the employer, as being appropriately trained and qualified to perform a specified checkout procedure.

Diverse-Redundancy

The practice of using components, circuitry or operation of different designs, architectures or functions to achieve redundancy and to reduce the possibility of common mode failures.

Dual-Channel

Having redundant signal lines for each safety input or safety output.

F

Fault

A state of a device characterized by the inability to perform a required function, excluding the inability during preventive maintenance or other planned actions, or due to lack of external resources. A fault is often the result of a failure of the device itself, but may exist without prior failure.

Final Switching Device (FSD)

The component of the machine's safety-related control system that interrupts the circuit to the machine primary control element (MPCE) when the output signal switching device (OSSD) goes to the OFF-state.

H

Hard (Fixed) Guard

Screens, bars, or other mechanical barriers affixed to the frame of the machine intended to prevent entry by personnel into the hazardous area(s) of a machine, while allowing the point of operation to be viewed. The maximum size of the openings is determined by the applicable standard, such as Table O-10 of OSHA 29CFR1910.217, also called a "fixed barrier guard."

I

ISD

The In-Series Diagnostics (ISD) communication protocol provides performance and status information from each device in a chain to the PLC and/or HMI. Notification is sent for the opening or closing of a door, mismatched or misaligned sensors and actuators, and a range of additional system health attributes.

M

Machine Primary Control Element (MPCE)

An electrically powered element, external to the safety system, which directly controls the machine's normal operating motion in such a way that the element is last (in time) to operate when machine motion is either initiated or arrested.

Machine Response Time

The time between the activation of a machine stopping device and the instant when the dangerous parts of the machine reach a safe state by being brought to rest.

Manual reset

The safety input device control operation setting where the assigned safety output will turn ON only after a manual reset is performed and if the other associated input devices are in their Run state.

O

OFF Signal

The safety output signal that results when at least one of its associated input device signals changes to the Stop state. In this manual, the safety output is said to be OFF or in the OFF state when the signal is 0 V DC nominally.

ON Signal

The safety output signal that results when all of its associated input device signals change to the Run state. In this manual, the safety output is said to be ON or in the ON state when the signal is 24 V DC nominally.

Open-Closed Debounce Time

Time to bridge a jittery input signal or bouncing of input contacts to prevent unwanted start of the machine. Adjustable from 10 ms to 500 ms. The default value is 50 ms.

P

Pass-Through Hazard

A pass-through hazard is associated with applications where personnel may pass through a safeguard (which issues a stop command to remove the hazard), and then continues into the guarded area, such as in perimeter guarding. Subsequently, their presence is no longer detected, and the related danger becomes the unexpected start or restart of the machine while personnel are within the guarded area.

PELV

Protected extra-low voltage power supply, for circuits with earth ground. Per IEC 61140: "A PELV system is an electrical system in which the voltage cannot exceed ELV (25 V AC rms or 60 V ripple free DC) under normal conditions, and under single-fault conditions, except earth faults in other circuits."

Q

Qualified Person

A person who, by possession of a recognized degree or certificate of professional training, or who, by extensive knowledge, training and experience, has successfully demonstrated the ability to solve problems relating to the subject matter and work.

R

Run Signal

The input signal monitored by the Controller that, when detected, causes one or more safety outputs to turn On, if their other associated input signals are also in the Run state.

S

SELV

Separated or safety extra-low voltage power supply, for circuits without earth ground. Per IEC 61140: "A SELV system is an electrical system in which the voltage cannot exceed ELV (25 V AC rms or 60 V ripple free DC) under normal conditions, and under single-fault conditions, including earth faults in other circuits."

Simultaneous (also Simultaneity)

The setting in which both channels must be off at the same time AND, when they turn back on, they must turn on within 3 seconds of each other. If both conditions are not satisfied, the input will be in a fault condition.

Single-Channel

Having only one signal line for a safety input or safety output.

StartUp Test

For certain safety devices, like safety light curtains or safety gates, it can be an advantage to test the device on power up at least one time for proper function.

Testing the device requires turning off of the outputs and then turning them back on.

Stop Signal

The input signal monitored by the Controller that, when detected, causes one or more safety outputs to turn OFF. In this manual, either the input device or device signal is said to be in the Stop state.

System Reset

A configurable reset of one or more safety outputs to turn ON after Controller power-up, when set for manual power-up, or lockout (fault detection) situations.

Index

A

- abbreviations 101
- accessories
 - SC10-2 343
 - XS/SC26 343
- ADC 297
- add
 - input 83
 - safety input 83
 - status output 87
- adjustable valve monitoring 48
- Analog to digital conversion 297
- AND 109
- assembly objects 122
- ATO 15, 19, 315, 317
- auto configure 117, 120–122
- AutoDetect ISD 313
- automatic terminal optimization 15, 19, 315, 317
- AVM 48

B

- bidirectional muting 302
- bypass 149, 303
- bypass block 136
- bypass switch 47
- Byte 168

C

- cable pull 38
- cancel delay 61, 303
- checkout 299–305
- cleaning 344
- commissioning checkout 299–305
- common wire 67
- configuration
 - mode 163, 164
 - sample 92
 - summary 163, 164
- configuration mode 164
- Configuration Summary tab 123
- confirming a configuration 89, 91
- control logic 88
- controller data
 - display 126
 - read 126
 - view 126
- controlling inputs 303
- CRC 61, 268
- CSV 170
- cycle initiation 55
- Cyclic Redundancy Check 61, 268

D

- daily checkout 299

- DAP 260
- data model 260, 287
- defaults 329
- delay
 - block 137
 - cancel 61, 303
- Device Access Point
 - , See DAP
- diagnostics
 - save safety controller 344
- dimensions 27
- display contrast 163, 164
- display controller data 126
- driver installation
 - verifying 333
- DWORD 168

E

- E-stop button 37, 301
- edge, safety 43, 44, 46
- EDM 70
- emergency stop button 37
- enabling device 39, 304
- enabling device block 138
- Equipment tab 106
- error codes 331
- ESI
 - install 294
- EtherCAT 286–296
- EtherCAT slave information 286
- Ethernet 9
- EtherNet/IP™ 170, 171, 174, 175, 182, 183, 189–191, 193, 195, 196, 198, 202–210, 212–217
- expansion modules
 - XS/SC26 11
- external device monitoring 70

F

- factory defaults 329
- fault codes
 - SC10-2 340
 - XS/SC26 335
- fault diagnostics 163, 164, 334, 335, 340
- faults 334, 335, 340
- FID 12, 18
- foot switch 57
- function block
 - bypass 136
 - delay 137
 - enabling device 138
 - latch reset 139
 - muting 143, 149–151
 - one shot 151

- press control 153–156, 158
- two-hand control 159, 162
- function blocks 9, 110, 136–139, 143, 149–151, 153–156, 158, 159, 162
- functional stops 14, 19
- Functional View tab 107–110

G

- gate, interlocked 39
- General Station Description
 - , See GSD
- GSD
 - Install 273
- guard, interlocked 39

H

- Hex 168

I

- in-series diagnostic 19
- indicator
 - status 307–310
- Industrial Ethernet tab 117, 120–122
- input device
 - safety 31–35
- input devices
 - non-safety 58–60
- interface
 - onboard 163, 164, 312
 - PC 101, 103, 105–111, 113, 117, 120–126, 128, 131, 134, 135
- interlocked gate 39
- interlocked guard 39
- internal logic 9
- IP address 167
- ISD 19, 49–51, 53, 54, 122
- ISD device-specific data 51, 53, 54, 202, 243, 257, 270
- ISD system status 50
- ISD tab 113

J

- jog 304
- jog output 304

L

- L5X 170, 171
- labels file 122
- Ladder Logic tab 113
- language

- selection of 103
- latch reset 303
- latch reset block 139
- LED 307–310
- LED status 307–310
- live mode 128, 312, 330
- lockout 312, 313
- logic blocks 9, 108–110

M

- mat, safety 43, 44, 46
- ME 149
- minimum distance
 - safety mat 44
 - two-hand control 41
- Modbus TCP 230, 231, 242, 243
- model # 163, 164
- models
 - SC10-2 17
 - XS/SC26 11
- mounting the safety controller 29
- mute
 - bypass 303
 - enable 149
 - sensor 56
 - time limit 150, 302
- mute lamp output 150
- mute-dependent override 302
- muting
 - bidirectional 302
 - one way 302
 - unidirectional 302
- muting block 143, 149–151
- muting sensor 46, 47

N

- NAND 109
- network settings
 - EtherCAT 121
 - Modbus TCP, Ethernet/IP, PCCC 120
 - PROFINET 121
- new configuration 88
- new project 105
- non-safety input devices 58–60
- NOR 110
- NOT 110

O

- Octet 168
- off-delay 303
- onboard interface 163, 164, 312
- onboard interface contrast 163, 164
- one shot block 151
- one way muting 302
- operating conditions 20, 24
- optical sensor 40, 301
- OR 109
- output

- functionality 80
- mute lamp 150
- override
 - mute-dependent 302

P

- password 9, 125
- password manager 9, 125
- PC requirements 27
- PCL tags 122
- PDO
 - turn off 295
 - turn on 296
- PDO menu 295
- periodic checkout 299
- PLCopenXML 287
- press control 55, 80, 94, 96
- press control block 153–156, 158
- press control mute sensor 56
- print 124
- printing configuration 124
- PROFINET 259, 260, 262–271, 273, 276, 279, 281, 284
- programming tool 10
- project settings 105
- protective stop 39, 301
- protective stop circuits 73

R

- RCD 61
- read controller data 126
- repairs 344
- replacement parts
 - SC10-2 343
 - XS/SC26 343
- retrieve current controller
 - information 126
- rope pull 38, 301
- RS Flip-Flop 110

S

- safety circuit integrity levels 37
- safety controller data
 - display 126
- safety distance
 - safety mat 44
 - two-hand control 41
- safety edge 43, 44, 46
- safety input device 31–35
- safety input device operation 301
- safety mat 43, 44, 46, 301
- safety output
 - off-delay 303
- safety outputs 13, 14, 64, 66, 67, 69, 70, 72, 73, 75, 78
- safety relay outputs 19
- safety stop 39
- safety stop circuits 73
- sample configuration 92, 94, 96, 97, 100

save

- configuration 89, 91
- project 89, 91
- save safety controller diagnostics 344
- SC-USB2 8
- SC-XM2 8, 10, 321–324
- SC-XM3 8, 10, 321–324, 328
- SC-XMP2 programming tool 10
- secondary output 304
- semi-annual checkout 299
- sequential stop 55
- set
 - display contrast 163, 164
 - onboard interface contrast 163, 164
- settings
 - project 105
- simulation mode 131, 134
- Simulation Mode tab 131, 134
- Software 29, 101, 103, 105–111, 113, 117, 120–126, 128, 131, 134, 135
- specifications
 - SC10-2 24
 - XS/SC26 20
- SQS 55
- SR Flip-Flop 110
- startup configuration 300
- status bits 289
- status indicator 307–310
- status output 78, 79
- status outputs
 - SC10-2 19
 - virtual 81
 - XS/SC26 14
- String 168
- switch
 - bypass 47
- system checkout 299
- system reset 312
- system status 163, 164

T

- tab
 - Configuration Summary 123
 - Equipment 106
 - Functional View 107–110
 - Industrial Ethernet 117, 120–122
 - ISD 113
 - Ladder Logic 113
 - Live Mode 128
 - Simulation Mode 131, 134
 - Wiring Diagram 111
- tags
 - PLC 122
- test pulse 19, 315
- THC
 - , See two-hand control
- time limit

- mute 150, 302
- two-hand control
 - with muting 301
 - without muting 301
- two-hand control block 159, 162
- two-way muting 302

U

- UDINT 168
- UINT 168
- unidirectional muting 302
- USB 8

V

- verifying driver installation 333
- view controller data 126
- virtual manual reset 61
- virtual non-safety input devices 60,
61, 63
- virtual status outputs
 - SC10-2 19
 - XS/SC26 14

W

- warranty 344

- Wiring Diagram tab 111
- Word 168

X

- XM2
 - , See SC-XM2
- XM3
 - , See SC-XM3
- XML file 122
- XOR 110