

MATERIAL NUMBER	ENGINEERING NUMBER	STUD SIZE	"S" ±.005/±0.13	STOCK THICKNESS REF	"W" ±.010/0.25	"C" MIN	"L" MAX	"ID" MIN
190720006	AA-420-02	02	.094/2.39	.028/0.71	.225/5.72	.157/3.99	.657/16.69	.062/1.57
190720008	AA-420-04	04	.119/3.02					
190720010	AA-420-06	06	.146/3.71					
190720012	AA-421-06							
190720014	AA-421-08	08	.173/4.39		.312/7.93	.270/6.86	.814/20.68	.062/1.57
190720016	AA-421-10	10	.198/5.03					
190720018	AA-421-209	209	.209/5.30					
190720025	AA-426-10	10	.198/5.03	.031/0.79	.534/13.56	.552/14.02	1.207/30.60	.054/1.37
190720026	AA-426-14	14	.265/6.73					
190720030	AA-426-56	56	.328/8.33					
190720028	AA-426-38	38	.390/9.91					

(B1)

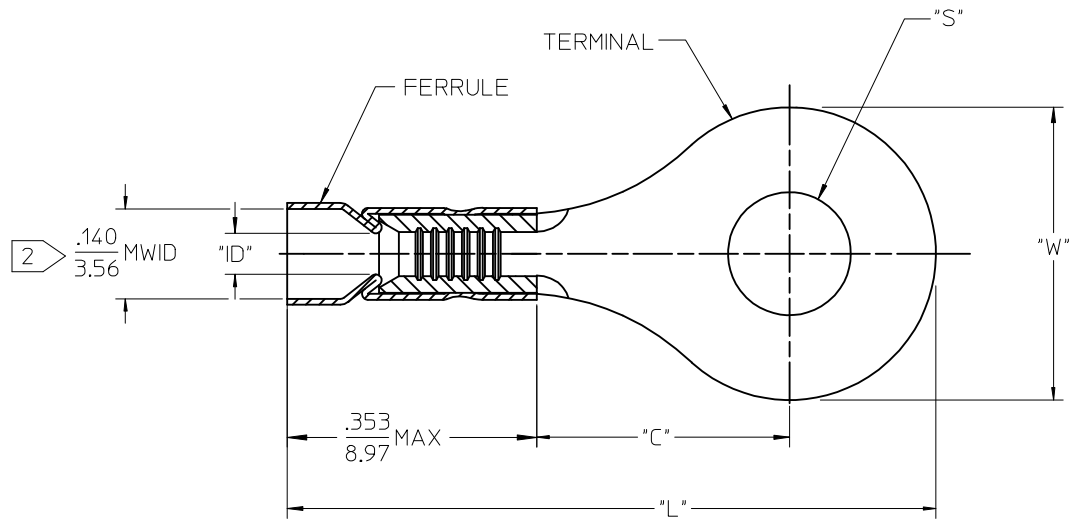

NOTES:

- MATERIAL: TERMINAL: COPPER
FUNNEL FERRULE: BRASS
PLATING: ELECTRO TIN.

② MWID = MAXIMUM WIRE INSULATION.

- PARTS ARE ROHS COMPLIANT.

SALES DRAWING

DELETE MILITARY NUMBERS EC NO: IPG2017-0896 DRWN: GRO/JAS01 2017/02/15 CHKD: JMACEIL 2017/02/15 APPR: JMACEIL 2017/03/30	QUALITY SYMBOLS	GENERAL TOLERANCES (UNLESS SPECIFIED)	SCALE 1:1	DESIGN UNITS INCH	THIRD ANGLE PROJECTION	REVISE ON CAD ONLY
	▽ = 0 ∇ = 0	mm INCH 4 PLACES ± --- ± --- 3 PLACES ± --- ± --- 2 PLACES ± --- ± --- 1 PLACE ± --- ± ---	DIMENSION STYLE IN/MM		TITLE	
		ANGULAR ±1/2° DRAFT WHERE APPLICABLE MUST REMAIN WITHIN DIMENSIONS	DRAWN BY DATE BENDERLE 2004/08/18 CHECKED BY DATE R DEROSS 2004/08/18 APPROVED BY DATE R DEROSS 2004/08/18	RING TONGUE TERMINAL VIBRAKRIMP 22-18 AWG		MOLEX INCORPORATED
	B1	THIS DRAWING CONTAINS INFORMATION THAT IS PROPRIETARY TO MOLEX INCORPORATED AND SHOULD NOT BE USED WITHOUT WRITTEN PERMISSION		MATERIAL NO. SEE CHART DOCUMENT NO. SD-19072-001 SHEET NO. 1 OF 1		

MATERIAL NUMBER	ENGINEERING NUMBER	STUD SIZE	"S" ±.005/±0.13	STOCK THICKNESS REF	"W" ±.010/0.25	"C" MIN	"L" MAX	"ID" MIN
190720006	AA-420-02	02	.094/2.39	.028/0.71	.225/5.72	.157/3.99	.657/16.69	.062/1.57
190720008	AA-420-04	04	.119/3.02					
190720010	AA-420-06	06	.146/3.71					
190720012	AA-421-06							
190720014	AA-421-08	08	.173/4.39		.312/7.93	.270/6.86	.814/20.68	.062/1.57
190720016	AA-421-10	10	.198/5.03					
190720018	AA-421-209	209	.209/5.30					
190720025	AA-426-10	10	.198/5.03	.031/0.79	.534/13.56	.552/14.02	1.207/30.60	.054/1.37
190720026	AA-426-14	14	.265/6.73					
190720030	AA-426-56	56	.328/8.33					
190720028	AA-426-38	38	.390/9.91					

(B1)

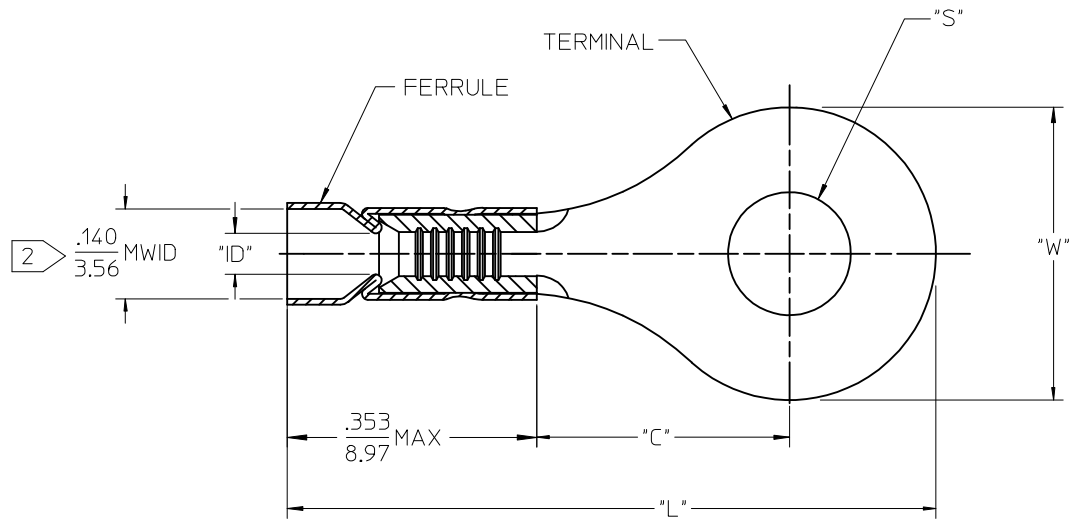

NOTES:

- MATERIAL: TERMINAL: COPPER
FUNNEL FERRULE: BRASS
PLATING: ELECTRO TIN.

2. MWID = MAXIMUM WIRE INSULATION.

- PARTS ARE ROHS COMPLIANT.

SALES DRAWING

DELETE MILITARY NUMBERS EC NO: IPG2017-0896 DRWN: GRO/JAS01 2017/02/15 CHKD: JMACEIL 2017/02/15 APPR: JMACEIL 2017/03/30	QUALITY SYMBOLS	GENERAL TOLERANCES (UNLESS SPECIFIED)	SCALE 1:1	DESIGN UNITS INCH	THIRD ANGLE PROJECTION	REVISE ON CAD ONLY
	▽ = 0 ∇ = 0	mm INCH 4 PLACES ± --- ± --- 3 PLACES ± --- ± --- 2 PLACES ± --- ± --- 1 PLACE ± --- ± ---	DIMENSION STYLE IN/MM		TITLE	
		ANGULAR ±1/2° DRAFT WHERE APPLICABLE MUST REMAIN WITHIN DIMENSIONS	DRAWN BY BENDERLE CHECKED BY R DEROSS APPROVED BY R DEROSS	DATE 2004/08/18 DATE 2004/08/18 DATE 2004/08/18	RING TONGUE TERMINAL VIBRAKRIMP 22-18 AWG	
	B1				MOLEX INCORPORATED SEE CHART	MATERIAL NO. SD-19072-001 DOCUMENT NO. SD-19072-001

THIS DRAWING CONTAINS INFORMATION THAT IS PROPRIETARY TO MOLEX INCORPORATED AND SHOULD NOT BE USED WITHOUT WRITTEN PERMISSION