

LOC	DIST	REVISIONS			
GP	00	REV	DATE	BY	APPD
		1	23NOV2011	TX	AC
		2	21DEC2011	TX	AC

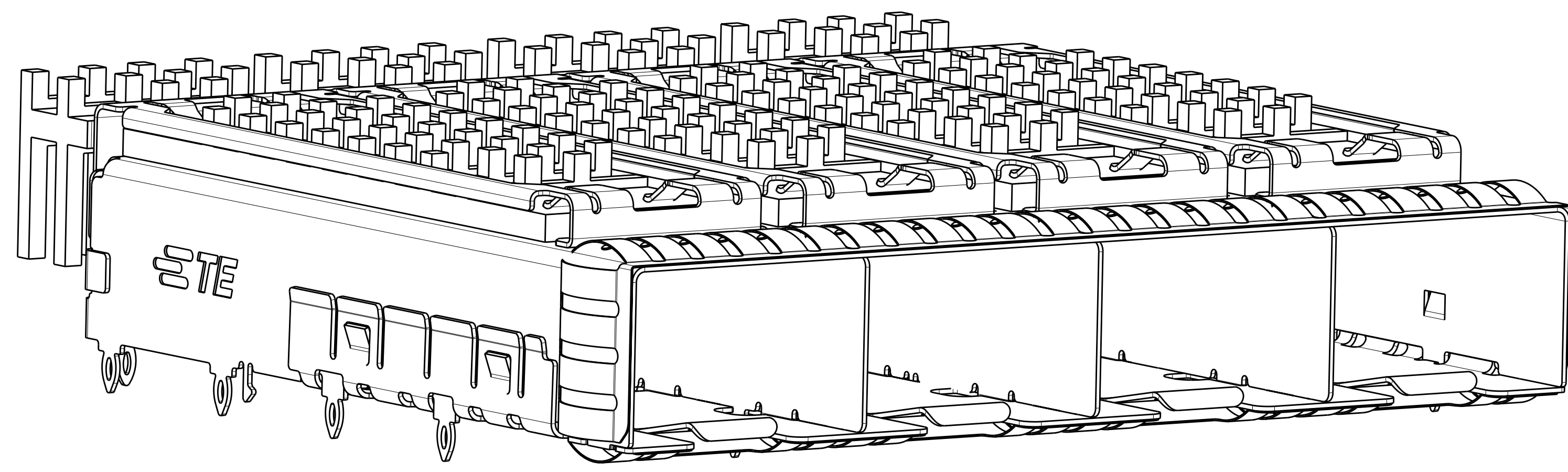

2170191-1
FINISHED ASSEMBLY

- 1 MATERIAL:
CAGE ASSEMBLY: 0.25mm THICK NICKEL SILVER ALLOY
HEATSINK CLIP: STAINLESS STEEL
HEATSINK: ALUMINUM
- 2 FINISH:
SPRINGS: MINIMUM OF 0.8um TIN PLATE OVER A MINIMUM OF 0.8um NICKEL UNDERPLATE.
NON-PLATED EDGES PERMISSIBLE.
HEATSINK: ELECTROLESS NICKEL
HEATSINK CLIP: PASSIVATE
- 3 PADS AND VIAS CHASSIS GROUND.
- 4 DATUM AND BASIC DIMENSION ESTABLISHED BY CUSTOMER.
- 5 MATES WITH SFP MSA COMPLIANT TRANSCEIVERS.
- 6 INTERPRETATION OF DATUM REFERENCE FRAME IN ACCORDANCE WITH SECT 4.4.1.1 OF ASME Y14.5M-1994.
- 7 REFERENCE APPLICATION SPEC. 114-13120, HOLE A, FOR RECOMMENDED DRILL HOLE DIAMETER AND PLATING THICKNESS.
- 8 REFERENCE APPLICATION SPEC. 114-13120, HOLE B, FOR RECOMMENDED DRILL HOLE DIAMETER AND PLATING THICKNESS.
- 9 HOLE PATTERN REPEATS FOR EACH PORT. SPACING BETWEEN PORTS IS 14.25mm.
- 10 MINIMUM PCB BOARD THICKNESS:
SINGLE SIDED = 1.50
DOUBLE SIDED = 2.25
- 11 CERTAIN MATING TRANSCEIVERS MAY REQUIRE ADDITIONAL PCB THICKNESS THAT WOULD BE DETERMINED BY THE CUSTOMER.
- 12 PRODUCT COMPLIES WITH SPECIFICATION SFF-8433 IMPROVED PLUGGABLE FORM FACTOR FOR SFP+ GANGED CAGES.
- 13 DIMENSION APPLIES PRIOR TO INSERTION OF SFP MODULE

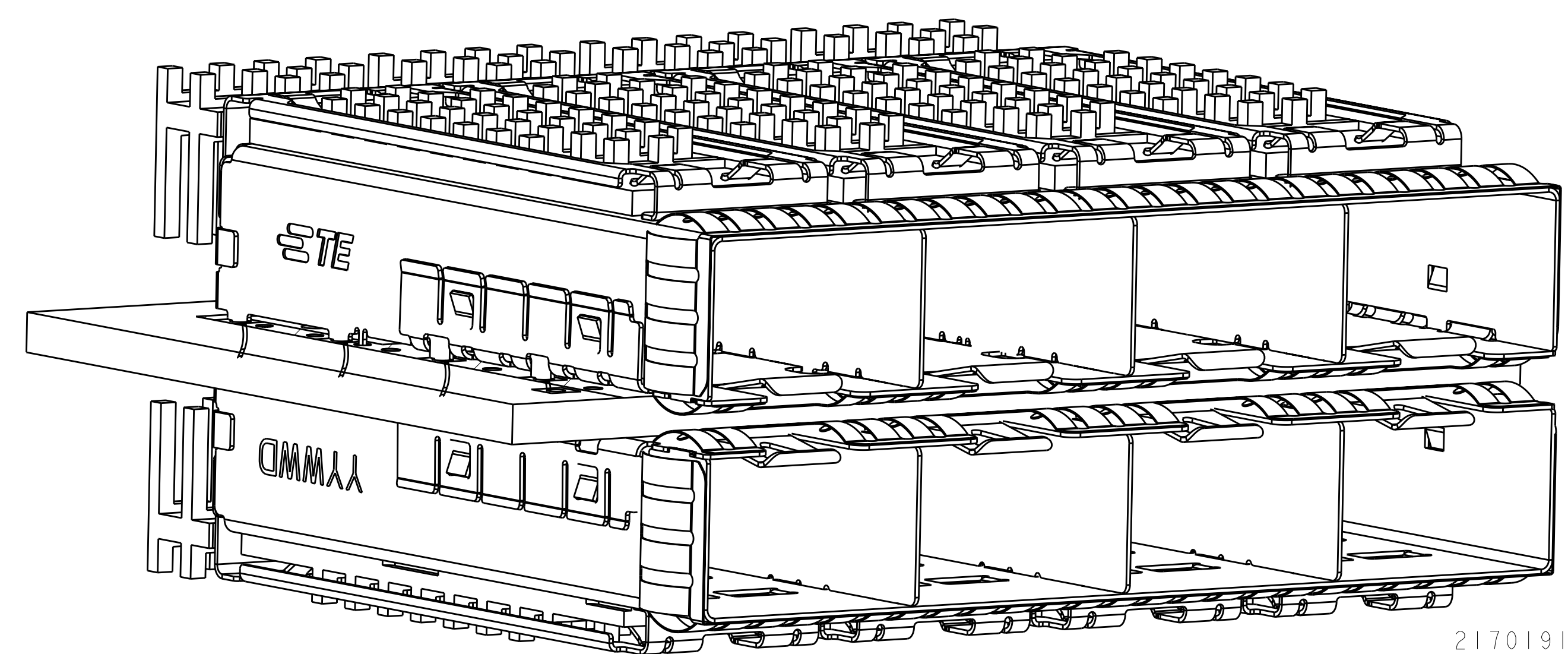
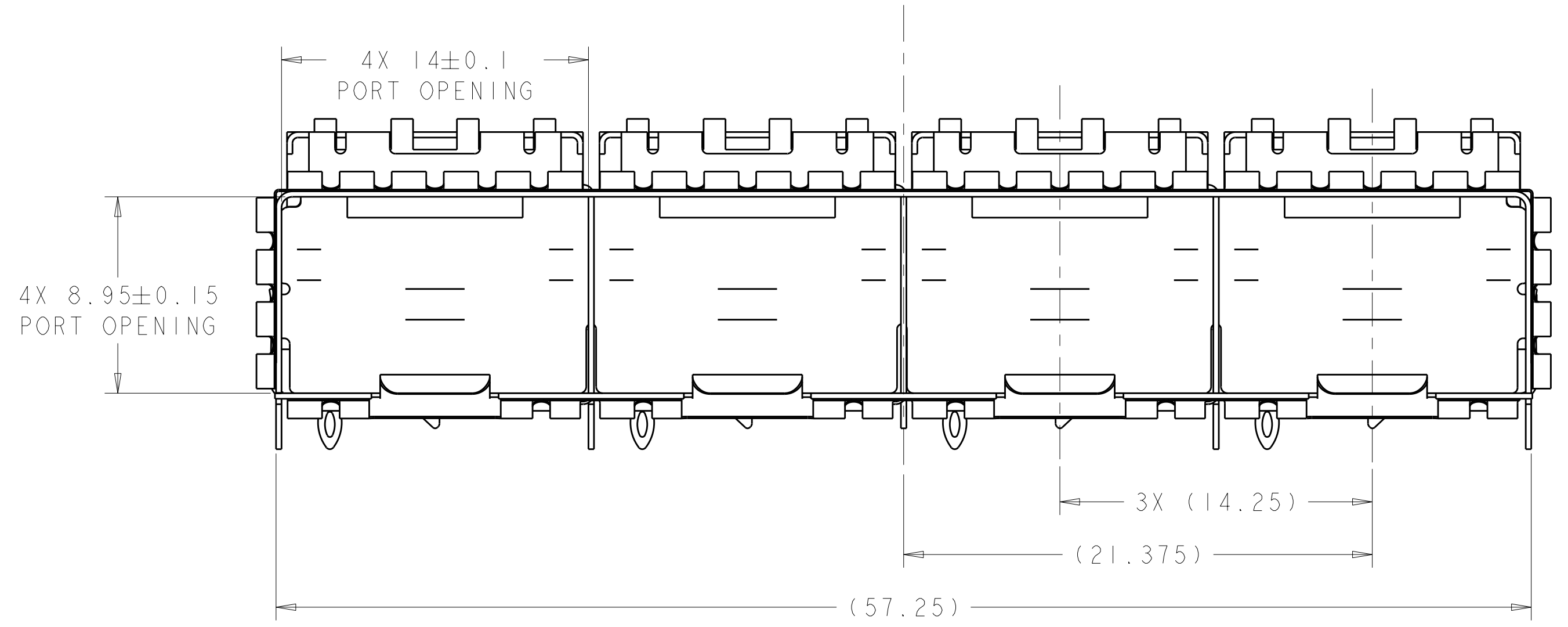
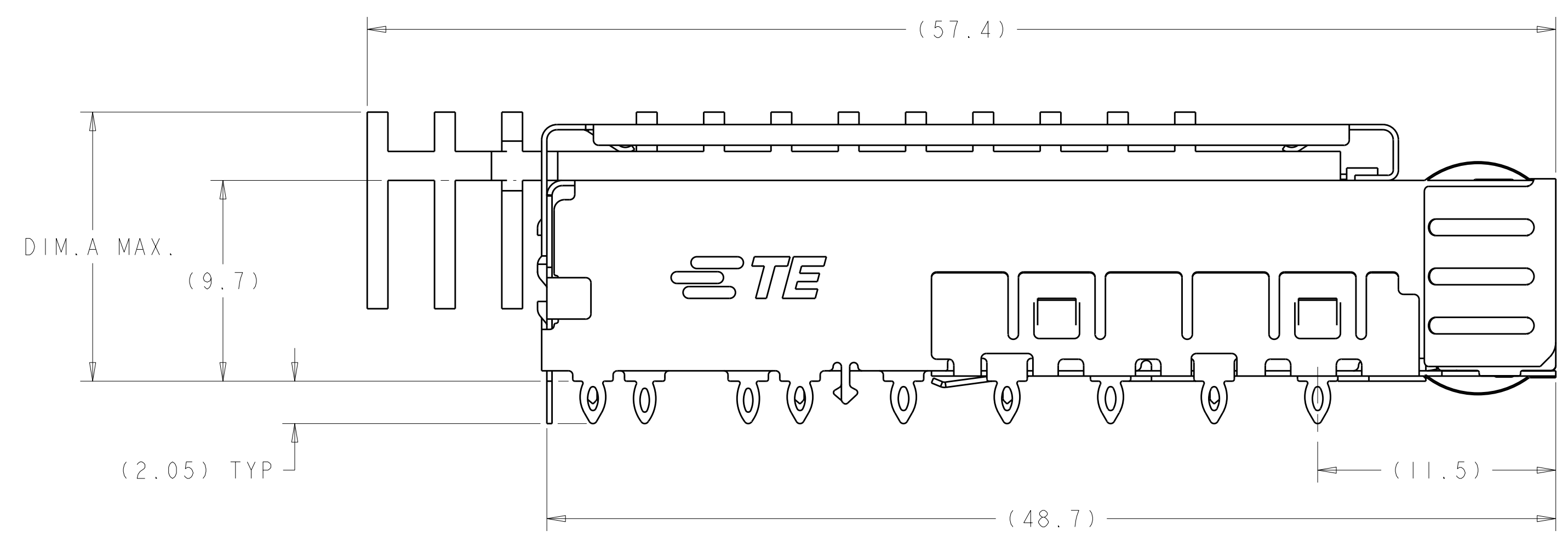

2170191-1
MOUNTED BELLY TO BELLY ON PCB
SCALE 4:1

A MAX	DESCRIPTION	PART NUMBER
20.2	HEAT SINK W/ THE FIRST ROW PIN	2170191-2
13	HEAT SINK W/O THE FIRST ROW PIN	2170191-1

THIS PRINT IS
PRELIMINARY
UNQUALIFIED PRODUCT
CONTACT PRODUCT ENGINEERING
BEFORE USING THIS PRINT

THIS DRAWING IS A CONTROLLED DOCUMENT.		DRN TIM XUE 23NOV2011	TE Connectivity
DIMENSIONS: mm		CHK ALEX CAI 23NOV2011	
TOLERANCES UNLESS OTHERWISE SPECIFIED:		APVD ALEX CAI 23NOV2011	NAME SFP+ ENHANCED 1X4 CAGE ASSEMBLY PRESS FIT, EXTERNAL EMI SPRINGS WITH HEATSINK
9 PLC ±0.1 1 PLC ±0.1 2 PLC ±0.1 3 PLC ±0.1 4 PLC ±0.1 ANGLES ±0.1°		PRODUCT SPEC 108-2364 APPLICATION SPEC 114-13120	
MATERIAL		WEIGHT	SIZE CAGE CODE DRAWING NO A100779C=2170191
FINISH		CUSTOMER DRAWING	RESTRICTED TO SCALE 5:1 SHEET 1 OF 5 REV 2

LOC	DIST	REVISIONS			
GP	00	REV	DATE	BY	APPD
		1	SEE SHEET 1		

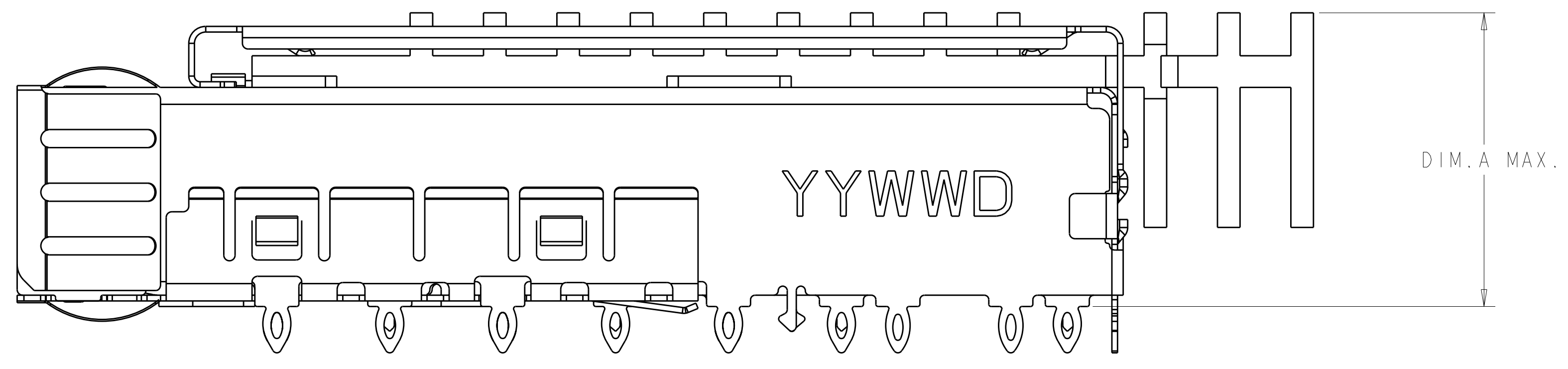

2170191-1 AS SHOWN
 HEAT SINK W/O THE FIRST ROW PIN

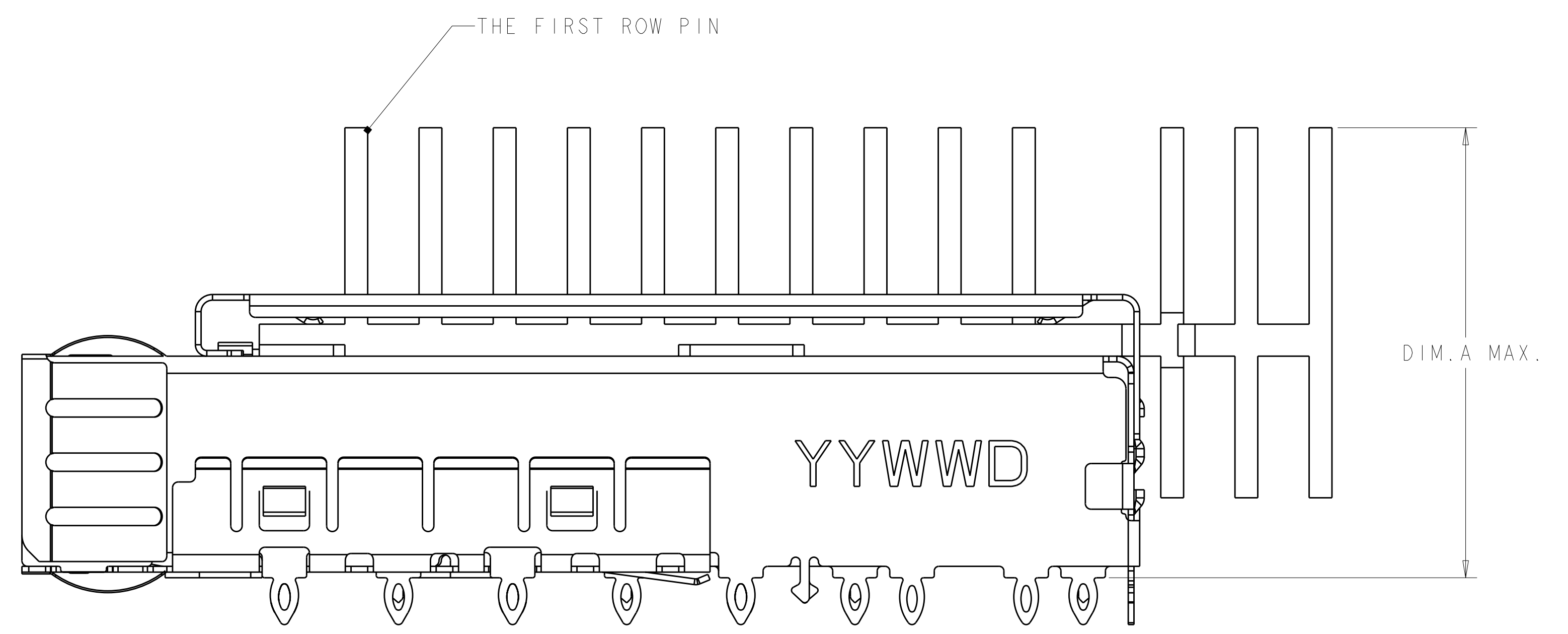

2170191-2 AS SHOWN

THIS DRAWING IS A CONTROLLED DOCUMENT.		DWN: TIM_XUE 23NOV2011 CHK: ALEX_CAI 23NOV2011 APVD: ALEX_CAI 23NOV2011	TE Connectivity
DIMENSIONS: mm	TOLERANCES UNLESS OTHERWISE SPECIFIED: 9 PLC ±0.1 1 PLC ±0.1 2 PLC ±0.1 3 PLC ±0.1 4 PLC ±0.1 ANGLES ±1°	NAME: SFP+ ENHANCED 1X4 CAGE ASSEMBLY PRESS FIT, EXTERNAL EMI SPRINGS WITH HEATSINK PRODUCT SPEC: 108-2364 APPLICATION SPEC: 114-13120	
MATERIAL: FINISH	WEIGHT: - CUSTOMER DRAWING	SIZE: A100779 CAGE CODE: C=2170191 RESTRICTED TO: -	SCALE: 5:1 SHEET: 2 OF 5 REV: 2

LOC	DIST	REV	DATE	BY	APPD
GP	00				

REV	DESCRIPTION	DATE	BY	APPD
-	SEE SHEET 1	-	-	-

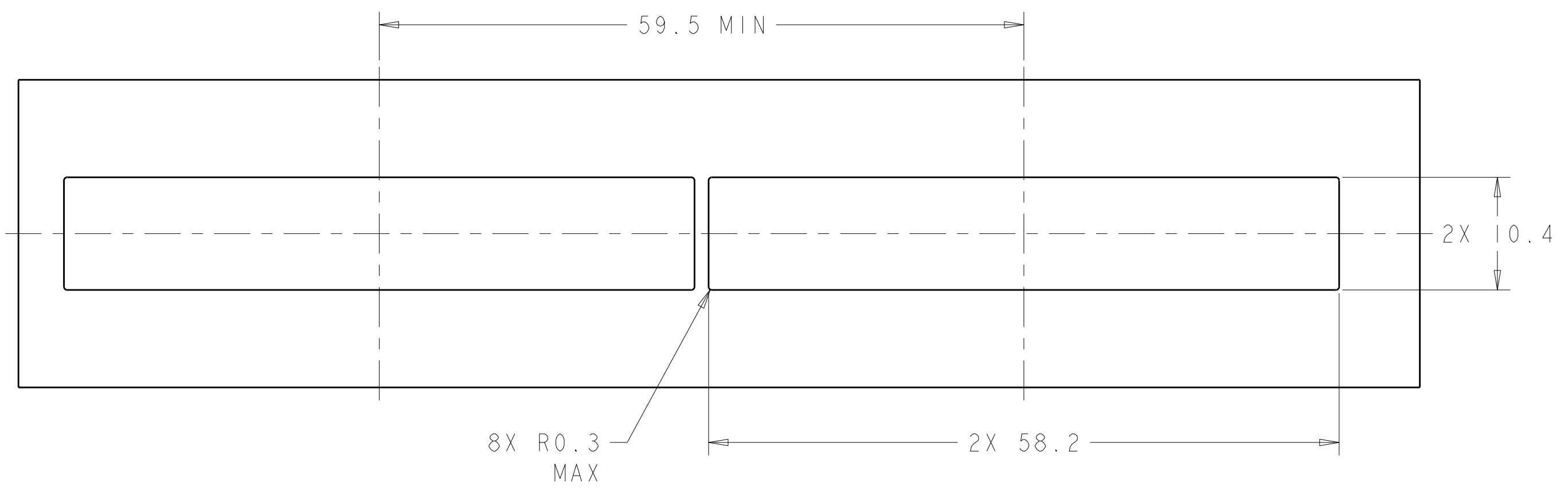

RECOMMENDED BEZEL CUT-OUT
SINGLE SIDED APPLICATIONS
SCALE 5:2

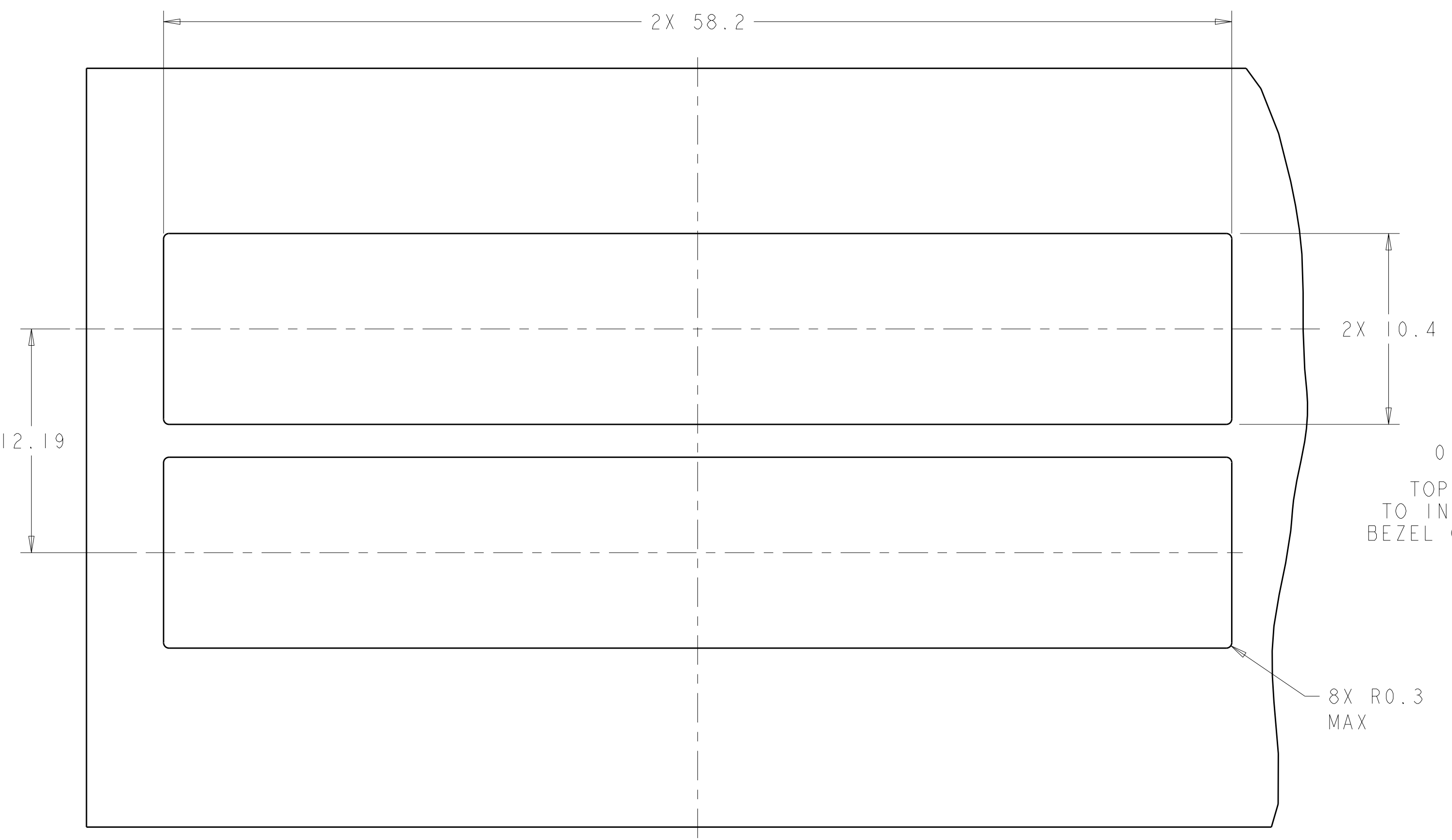

RECOMMENDED BEZEL CUT-OUT
BELLY TO BELLY APPLICATIONS

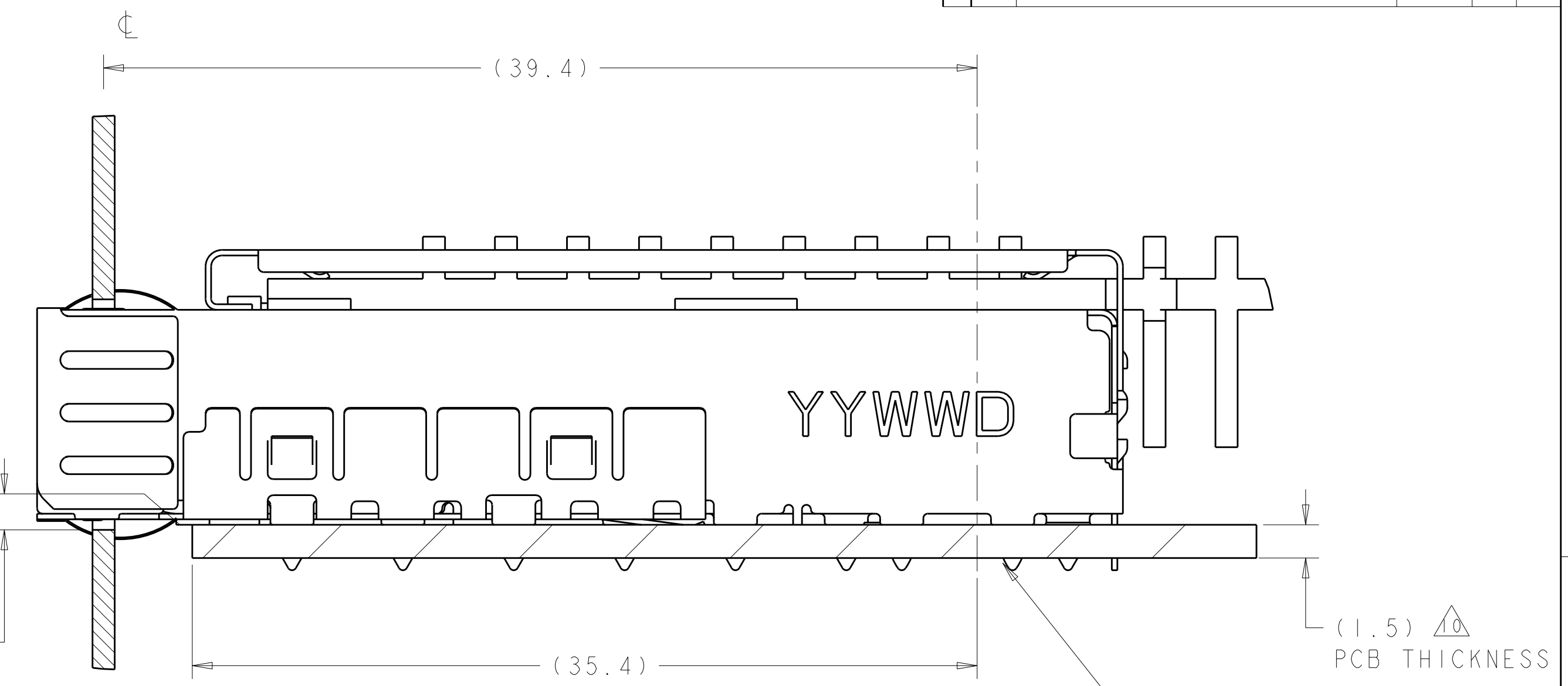

2149730
MOUNTED ON PC BOARD
SHOWN THRU RECOMMENDED BEZEL

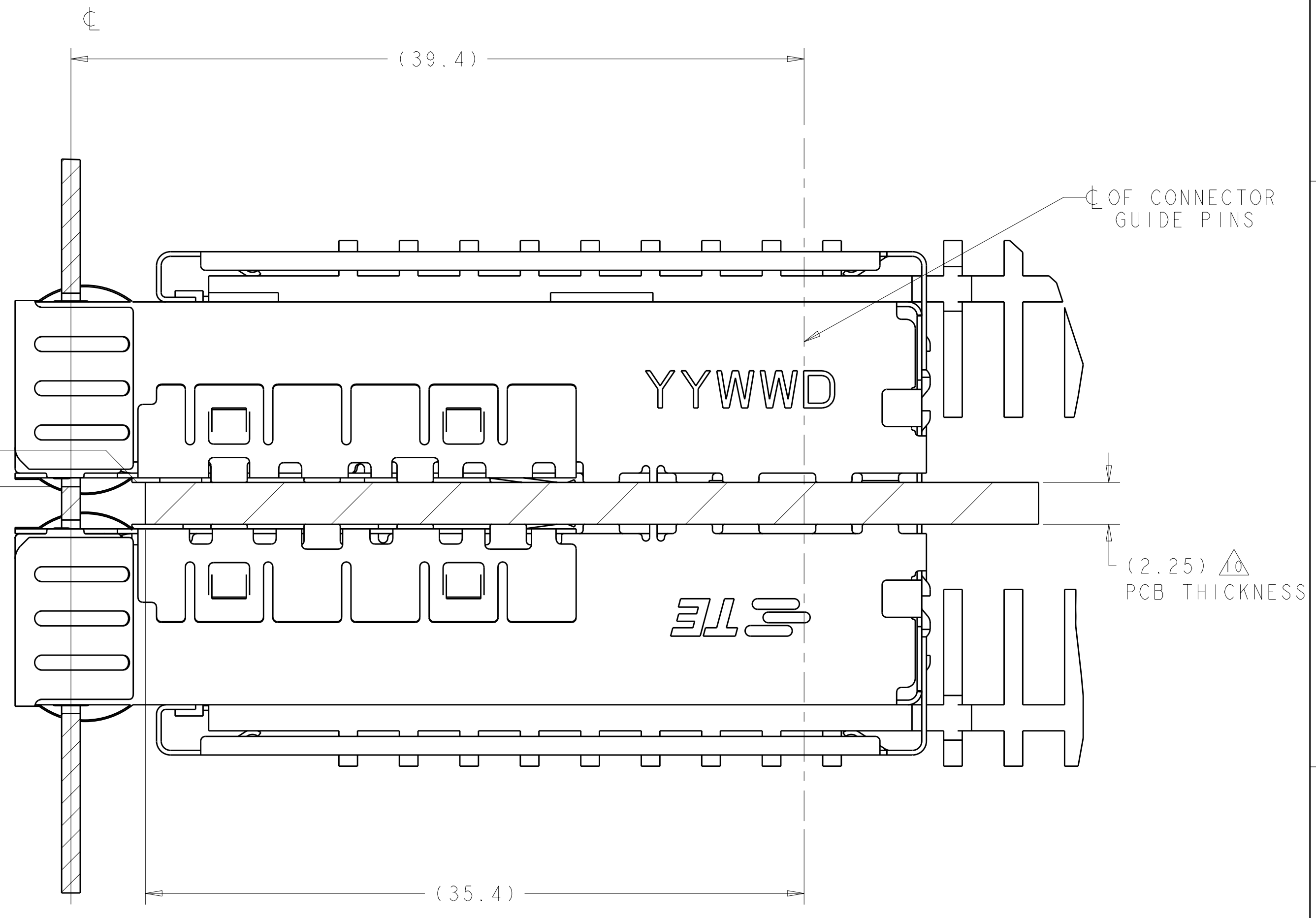

2149730
MOUNTED BELLY TO BELLY ON PC BOARD
SHOWN THRU RECOMMENDED BEZEL

THIS PRINT IS
PRELIMINARY
UNQUALIFIED PRODUCT
CONTACT PRODUCT ENGINEERING
BEFORE USING THIS PRINT

THIS DRAWING IS A CONTROLLED DOCUMENT.		DRN	TIM_XUE	23NOV2011
DIMENSIONS:		CHK	ALEX_CAI	23NOV2011
mm		APPD	ALEX_CAI	23NOV2011
TOLERANCES UNLESS OTHERWISE SPECIFIED:		PRODUCT SPEC	108-2364	
9 PL	±0.1	APPLICATION SPEC	114-13120	
2 PL	±0.1	WEIGHT		
3 PL	±0.1	CUSTOMER DRAWING		
5 PL	±0.1			
4 PL	±0.1			
ANGLES	±1°			
MATERIAL		SIZE	CAGE CODE	DRAWING NO
FINISH		A100779	C=2170191	
		SCALE	5:1	SHEET 3 OF 5
		REV	2	

LOC	DIST	REV	DATE	BY	APPD
GP	00				

REV	DATE	BY	APPD	DESCRIPTION
-	-	-	-	SEE SHEET 1

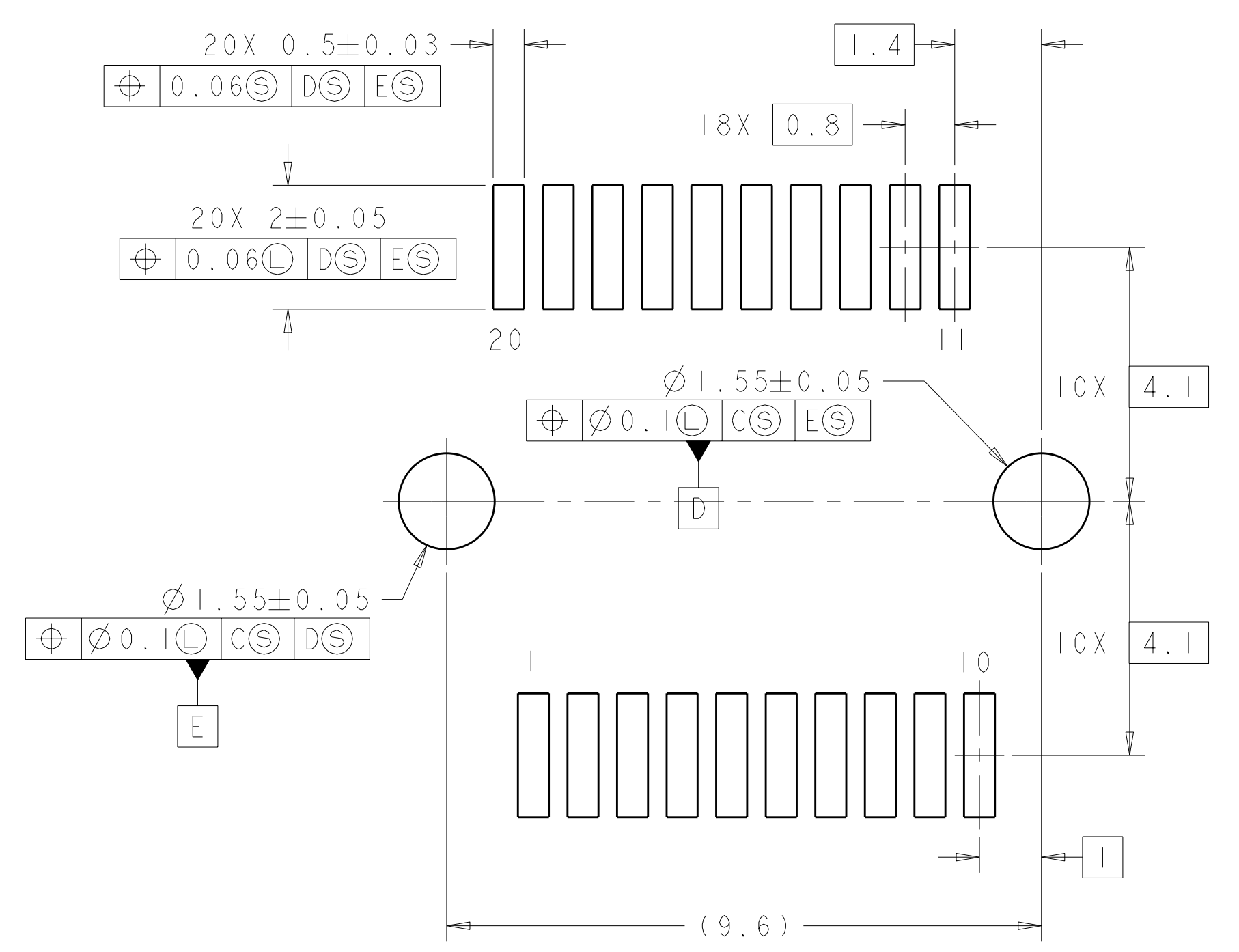
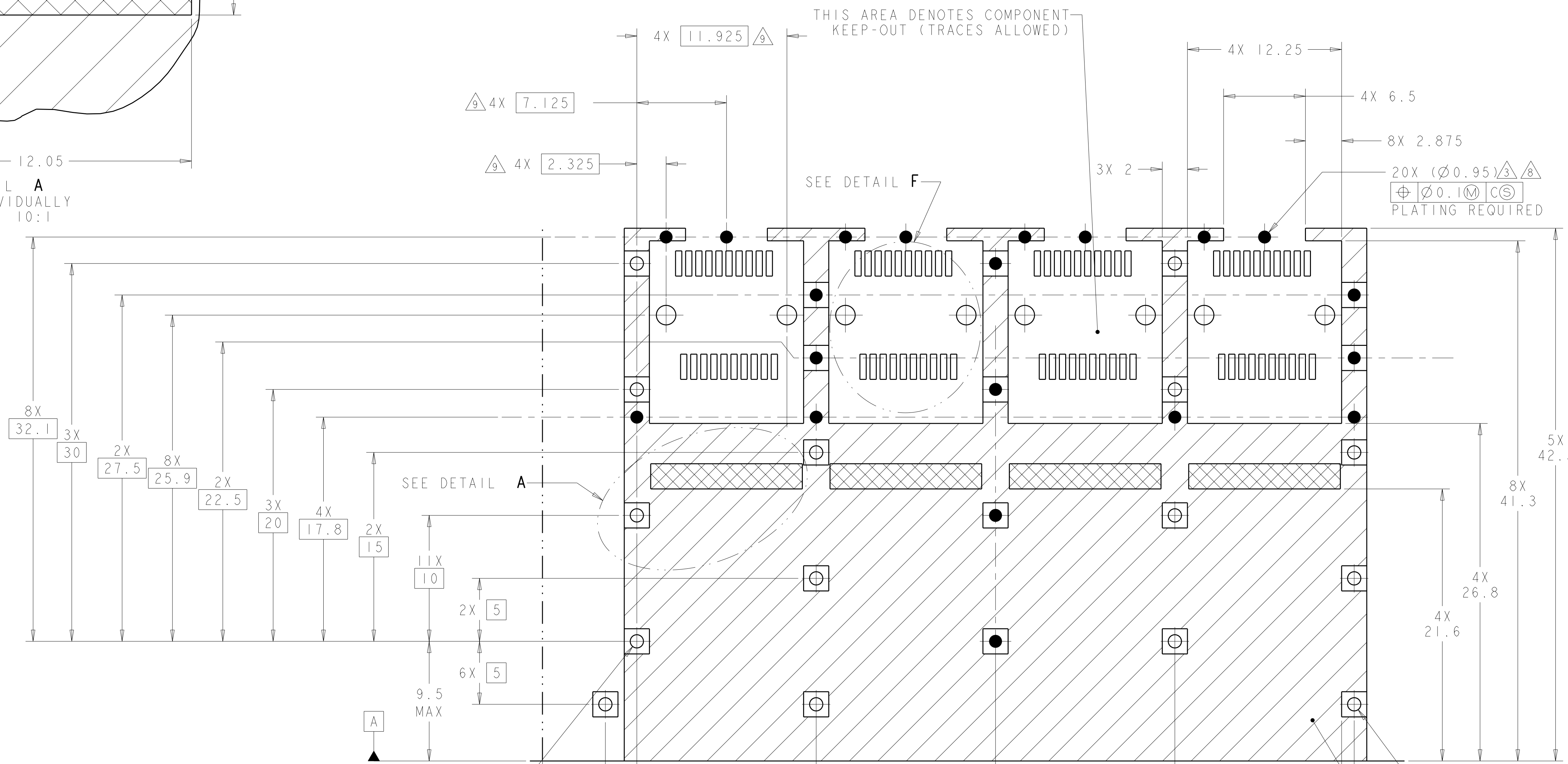
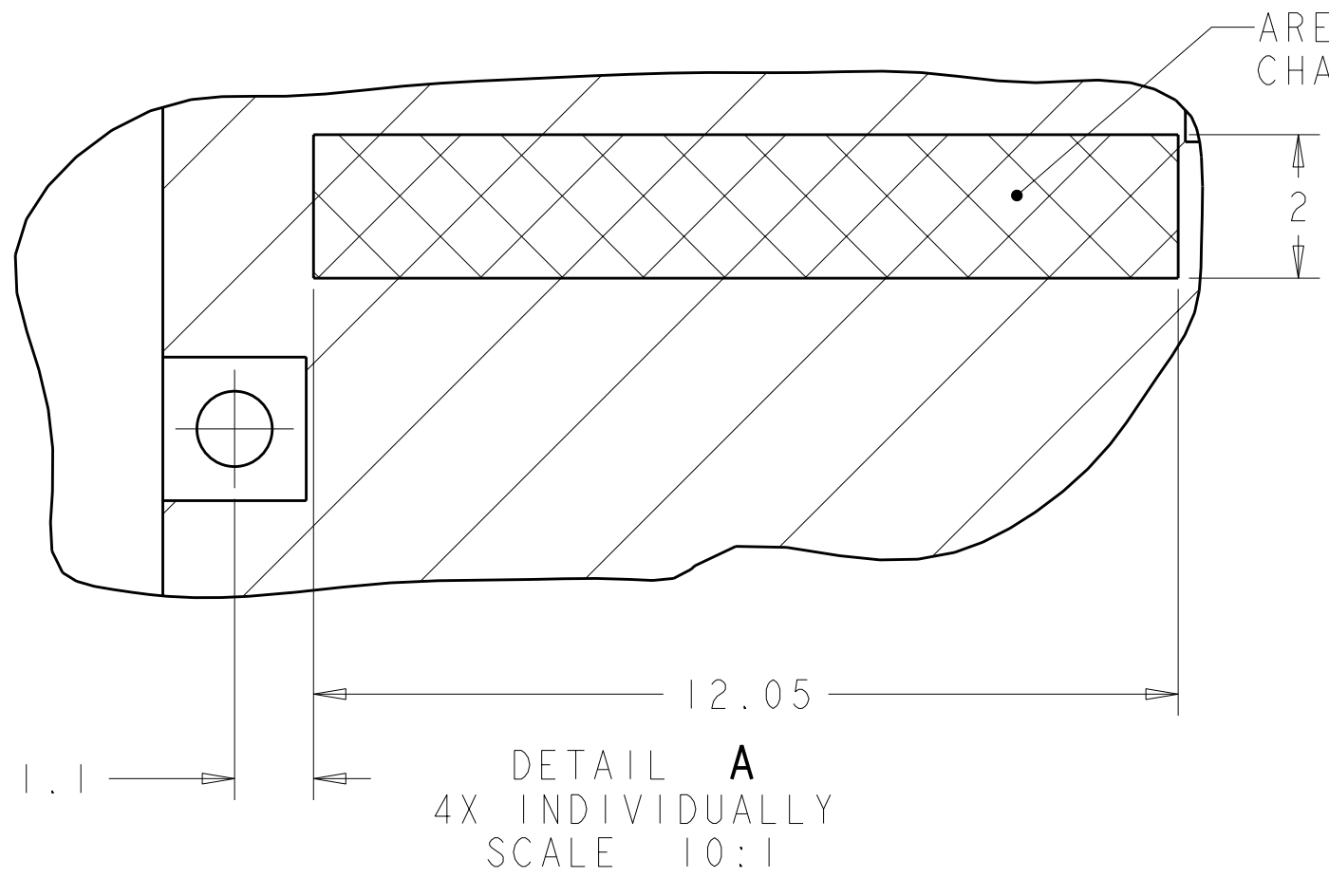

RECOMMENDED PCB CONFIGURATION WITH KEEP-OUT AREAS
SINGLE SIDED APPLICATIONS
SCALE 5:1

THIS PRINT IS
PRELIMINARY
UNQUALIFIED PRODUCT
CONTACT PRODUCT ENGINEERING
BEFORE USING THIS PRINT

THIS DRAWING IS A CONTROLLED DOCUMENT.		OWN: TIM XUE 23NOV2011	TE Connectivity
DIMENSIONS: mm		CHK: ALEX CAI 23NOV2011	
TOLERANCES UNLESS OTHERWISE SPECIFIED:		APVD: ALEX CAI 23NOV2011	NAME: SFP+ ENHANCED 1X4 CAGE ASSEMBLY PRESS FIT, EXTERNAL EMI SPRINGS WITH HEATSINK PRODUCT SPEC: 108-2364 APPLICATION SPEC: 114-13120 WEIGHT: - CUSTOMER DRAWING
9 PLC ±0.1 1 PLC ±0.1 2 PLC ±0.1 3 PLC ±0.1 4 PLC ±0.1 ANGLES ±1°		SIZE: CAGE CODE DRAWING NO: A100779C=2170191 RESTRICTED TO: -	
MATERIAL: △		FINISH: △	
SCALE: 5:1		SHEET: 4 OF 5	

LOC	DIST	REV	DATE	BY	APPD
GP	00				

REVISIONS		DATE	BY	APPD
1	SEE SHEET 1			

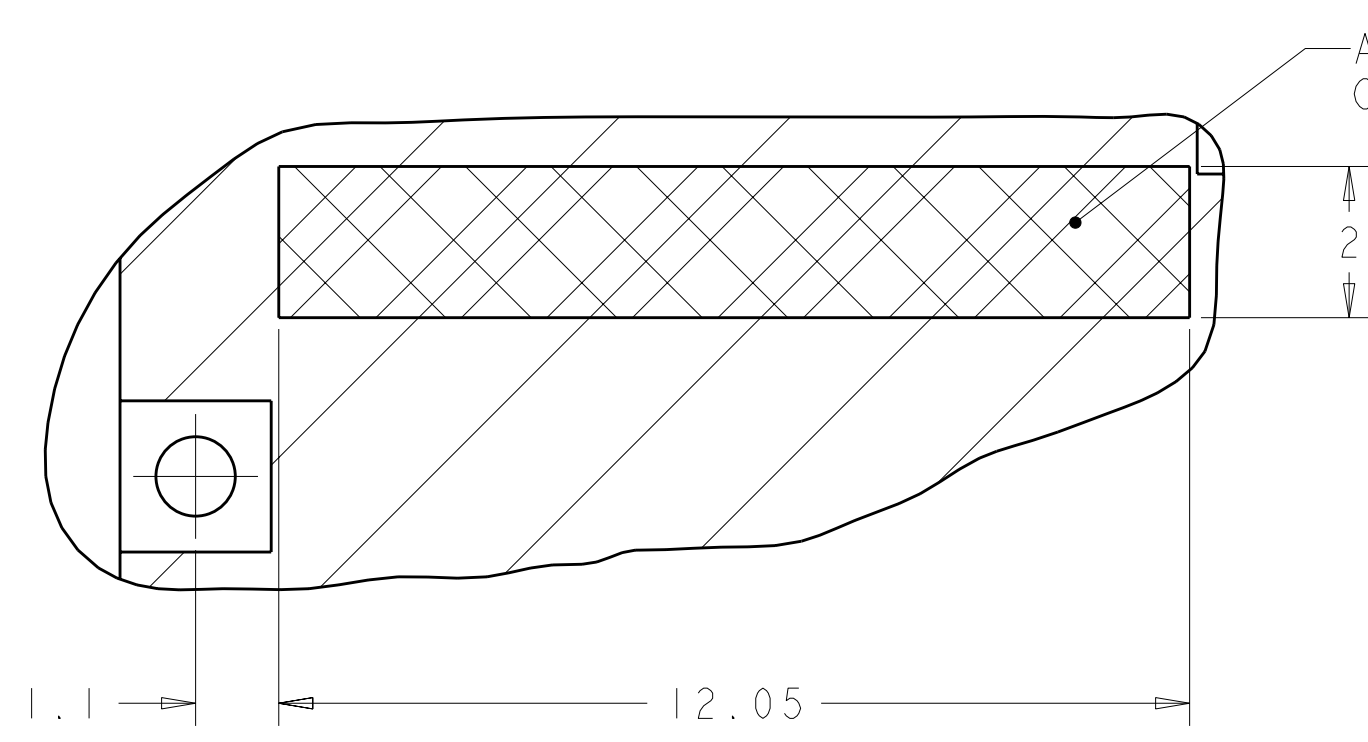

DETAIL B
4X INDIVIDUALLY
SCALE 10:1

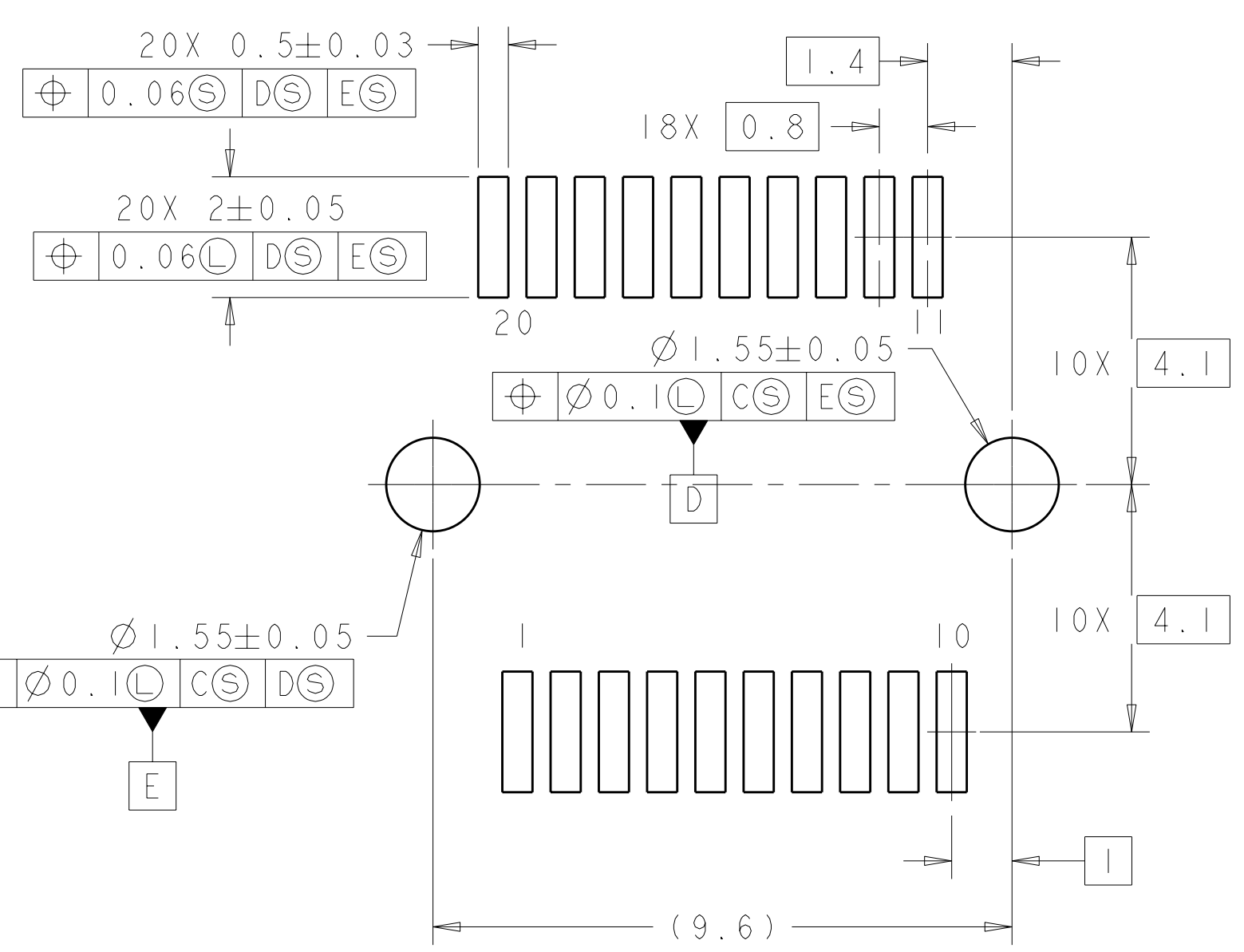
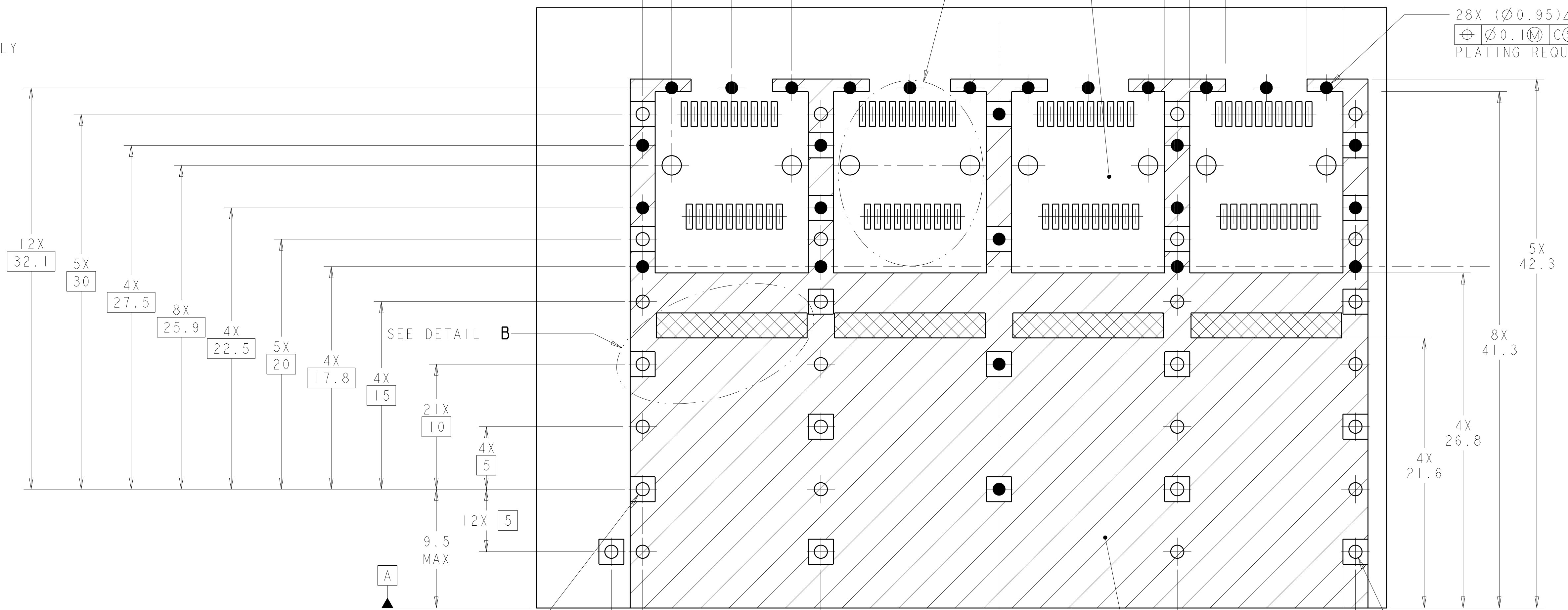
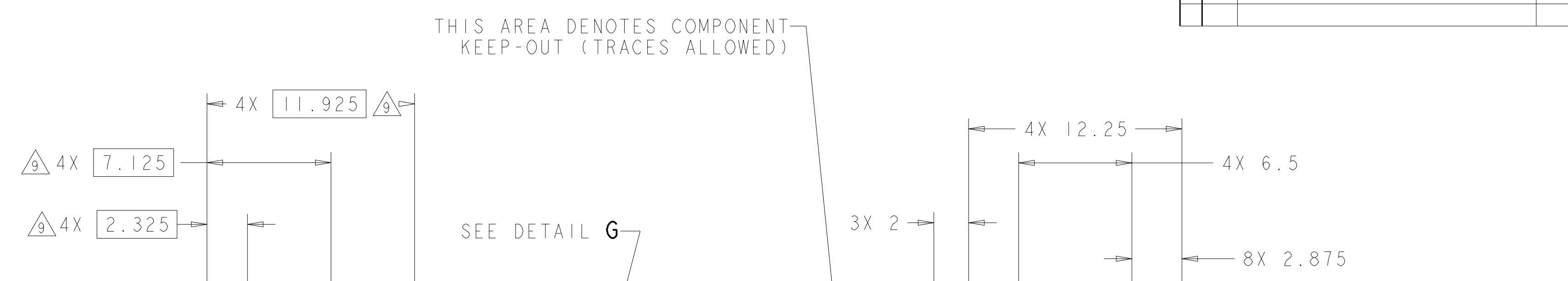

DETAIL G
RECOMMENDED PT CONNECTOR LAYOUT
8X INDIVIDUALLY
SCALE 10:1

THIS PRINT IS
PRELIMINARY
UNQUALIFIED PRODUCT
CONTACT PRODUCT ENGINEERING
BEFORE USING THIS PRINT

RECOMMENDED PCB CONFIGURATION
WITH KEEP-OUT AREAS
BELLY TO BELLY APPLICATIONS
SCALE 5:1

CROSS-HATCHED AREA DENOTES
COMPONENT AND TRACE KEEP-OUT
(EXCEPT CHASSIS GROUND)

THIS DRAWING IS A CONTROLLED DOCUMENT.		DATE: 23NOV2011	STE TE Connectivity
DIMENSIONS: mm		DRW: TIM_XUE	
TOLERANCES UNLESS OTHERWISE SPECIFIED:		CHK: ALEX_CAI	NAME: SFP+ ENHANCED 1X4 CAGE ASSEMBLY PRESS FIT, EXTERNAL EMI SPRINGS WITH HEATSINK
Ø 0.1		APPD: ALEX_CAI	
9 PLC ±0.1		PRODUCT SPEC	SIZE: CAGE CODE DRAWING NO. RESTRICTED TO
1 PLC ±0.1		108-2364	
3 PLC ±0.1		APPLICATION SPEC	A100779C-2170191
4 PLC ±0.1		WEIGHT	
ANGLES ±1°		CUSTOMER DRAWING	SCALE: 5:1 SHEET 5 OF 5 REV 2