

TMC4671-LEV-REF HW & FW Manual

Hardware Version V1.00 | Document Revision V1.00 • 2021-01-15

TMC4671-LEV-REF is an open source reference design for LEVs (Light Electric Vehicles). It is a BLDC servo driver for voltages up to +55V (ca. 13S) and up to 500W motor power. It offers a wide range of connectivity to external sensors, position feedback systems, and GPIO as well as supports external lights on the LEV. A CAN and a TTL UART interface are available for communication. A CAN and a TTL UART interface are available for communication.

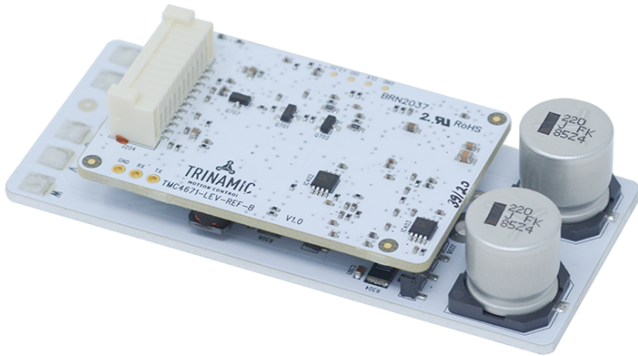

Features

- Single axis BLDC servo driver
- Up to 500W continuous
- Supply Voltage up to 13S (<55V)
- HALL sensor interface
- CAN & UART communication interface
- 3x GPIO
- Sin/Cos and torque sensor interface
- External light support for LEV
- Onboard MEMS motion sensor
- Open source hardware and firmware

Applications

- LEV
- E-bikes
- AGV
- Small scooters
- E-Monowheels
- E-Skateboards

Simplified Block Diagram

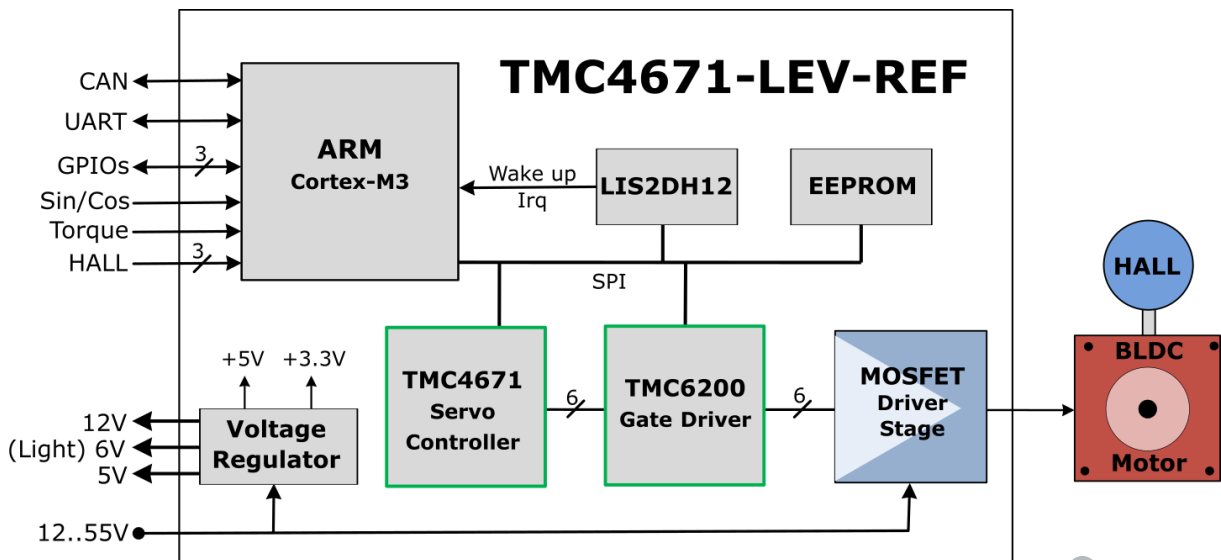

©2021 TRINAMIC Motion Control GmbH & Co. KG, Hamburg, Germany
 Terms of delivery and rights to technical change reserved.
 Download newest version at: www.trinamic.com



Read entire documentation.

Contents

1	Module Features	3
1.1	Open Source	4
2	Order Codes	5
3	Mechanical Information	6
4	Connectors and LEDs	7
4.1	Motor and Supply Connectors	7
4.2	I/O and Interface Connector	8
4.3	Optional UART Header	11
4.4	SWD Programming Pads	11
5	Firmware Description	12
5.1	TMCL Protocol	12
5.1.1	Binary Request Format	12
5.1.2	Binary Reply Format	12
5.2	Open Source Firmware Project	13
5.2.1	Introduction	13
5.2.2	Boot Loader	13
5.2.3	Software Functions	14
5.2.4	Supported TMCL Commands	14
5.2.5	Axis Parameters	18
5.2.6	Using the TMCL-IDE with the Board	23
5.3	Writing your own Firmware	23
6	Operational Ratings and Characteristics	24
6.1	Absolute Maximum Ratings	24
6.2	Electrical Characteristics (Ambient Temperature 25°C)	24
6.3	I/O Ratings (Ambient Temperature 25°C)	24
6.4	Other Requirements	25
7	Figures Index	26
8	Tables Index	27
9	Supplemental Directives	28
9.1	Producer Information	28
9.2	Copyright	28
9.3	Trademark Designations and Symbols	28
9.4	Target User	28
9.5	Disclaimer: Life Support Systems	28
9.6	Disclaimer: Intended Use	28
9.7	Collateral Documents & Tools	29
10	Revision History	30
10.1	Hardware Revision	30
10.2	Firmware Revision	30
10.3	Document Revision	30



1 Module Features

TMC4671-LEV-REF is an open source reference design for LEVs (Light Electric Vehicles). It is a BLDC servo driver for voltages up to +55V (ca. 13S) and up to 500W motor power. It offers a wide range of connectivity to external sensors, position feedback systems, and GPIO as well as supports external lights on the LEV. A CAN and a TTL UART interface are available for communication.

- Supply Voltage up to 13S (up to +55V)
- Motor phase currents up to 35A RMS
- Up to 500W continuous power
- HALL sensor interface with +5V/100mA sensor supply
- CAN interface for communication and control
- Optional digital UART interface
- 3x GPIO and/ or LED control
- External torque and speed sensor interface
- On-board digital MEMS motion sensor LIS2DH12
- External +5V/0.1A rail for sensors
- External +6V/2A rail for lights/LED support
- External +12V/0.5A rail for sensors
- TMCL-based firmware for configuration and permanent parameter storage



1.1 Open Source

This is an Open Source project! The following data is available as Open Source for download and own use on GitHub:

<https://github.com/trinamic/TMC4671-LEV-REF>

- Module design, layout, and manufacturing data for the TMC4671-LEV-REF
- 3D CAD files
- Complete firmware sources and Eclipse CDT based project files for the TMC4671-LEV-REF

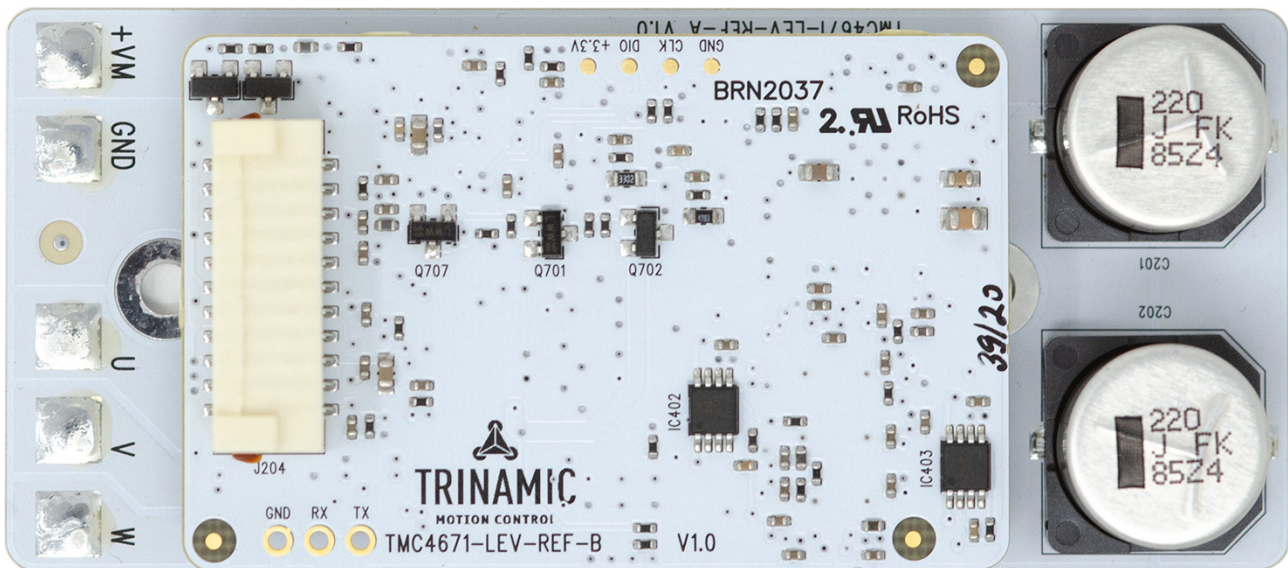

Figure 1: LEV Reference Design with Controller and Driver Board



2 Order Codes

Order Code	Description	Size (LxWxH)
TMC4671-LEV-REF	Reference Design Module for LEVs, double board stack, 500W, CAN interface, driving lights & torque sensor support	80x35x (mm)

Table 1: Order codes



3 Mechanical Information

The TMC4671-LEV-REF is a stack of 2 boards. The top board is a standard FR4 PCB and works as the controller board. The bottom board is a single layer aluminum PCB and works as the power driver board.

The size of TMC4671-LEV-REF is approximately 80mm x 35mm.

There are two M3 mounting holes for mounting the TMC4671-LEV-REF onto a heat sink.

The maximum component height of both stacked boards is approximately 20mm.

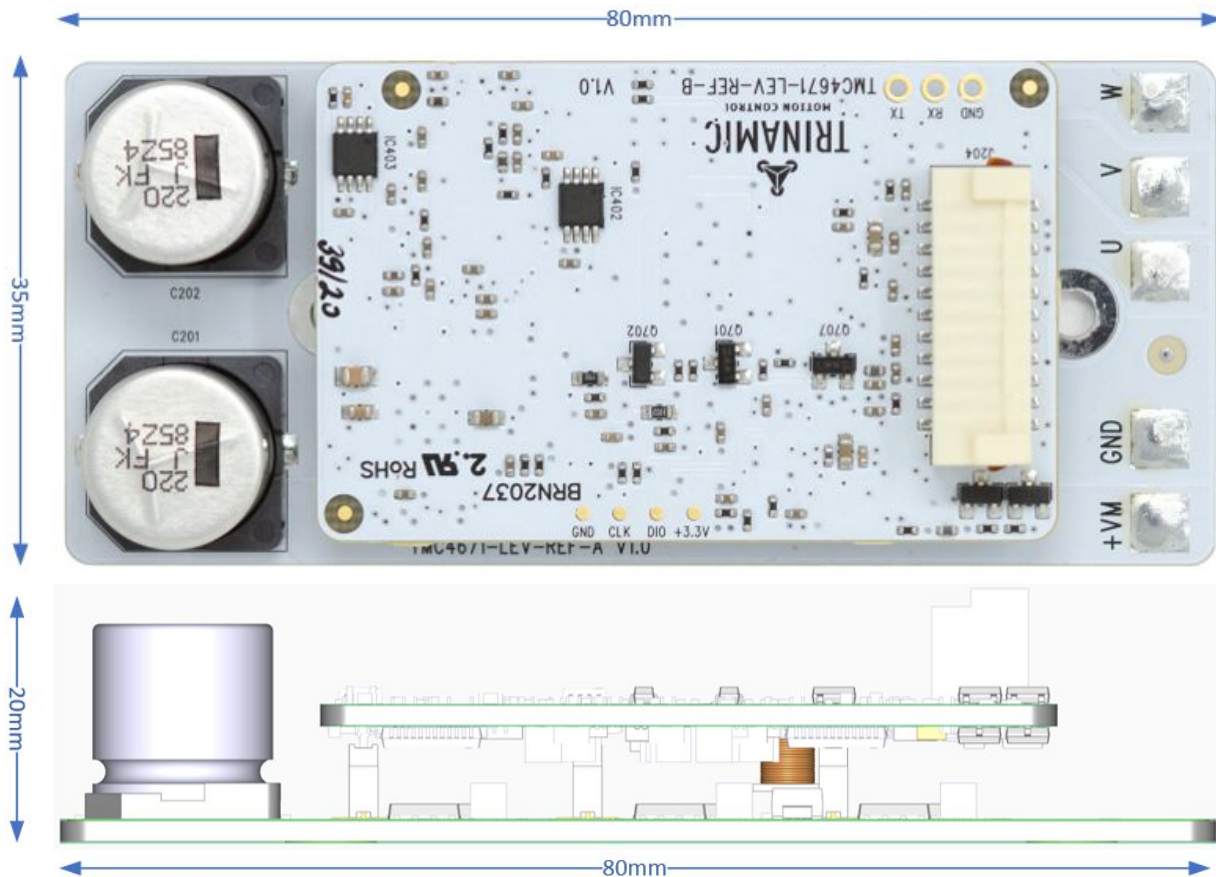

Figure 2: TMC4671-LEV-REF top view mechanical dimensions

4 Connectors and LEDs

Connector types, pitch, and more information on the I/O signals and pin-out can be derived directly from the original/latest CAD and manufacturing data available as Open Source on GitHub:

<https://github.com/trinamic/TMC4671-LEV-REF>

4.1 Motor and Supply Connectors

The motor and supply connections are pads for direct soldering of wires.

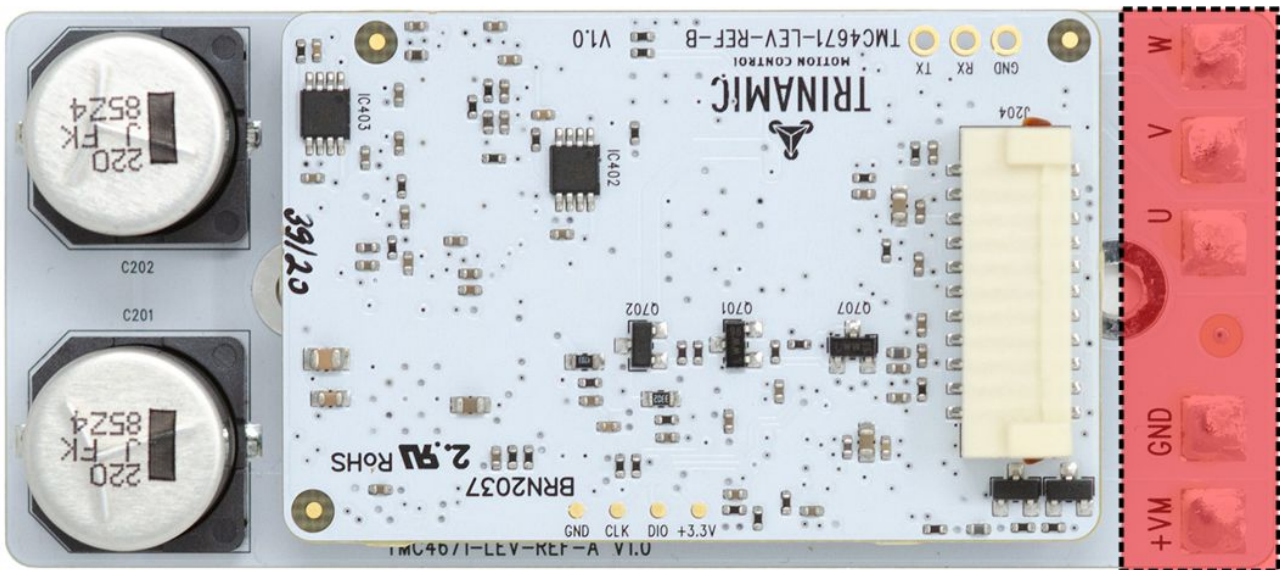

Figure 3: TMC4671-LEV-REF motor and power connectors

Pin #	Signal / Label	Description	Range [Units]	Units
-	+VM	Supply voltage / battery +	0...+55	V
-	GND	Supply ground / battery -		
-	U	Motor phase U	0...+55	V
-	V	Motor phase V	0...+55	V
-	W	Motor phase W	0...+55	V

4.2 I/O and Interface Connector

The I/O and interface connector is a 22-pin right-angle connector of type JST ZPD Series.

- Part number: SM22B-ZPDSS-TF(LF)(SN)
https://www.jst-mfg.com/product/detail_e.php?series=581
- Mating connector: ZPDR-22V-S
<http://www.jst-mfg.com/product/pdf/eng/eZPD.pdf>
- Crimp terminals: SZPD-002T-P0.3
<https://www.digikey.de/product-detail/de/jst-sales-america-inc/SZE-002T-P0-3/455-2571-1-ND/2619092>

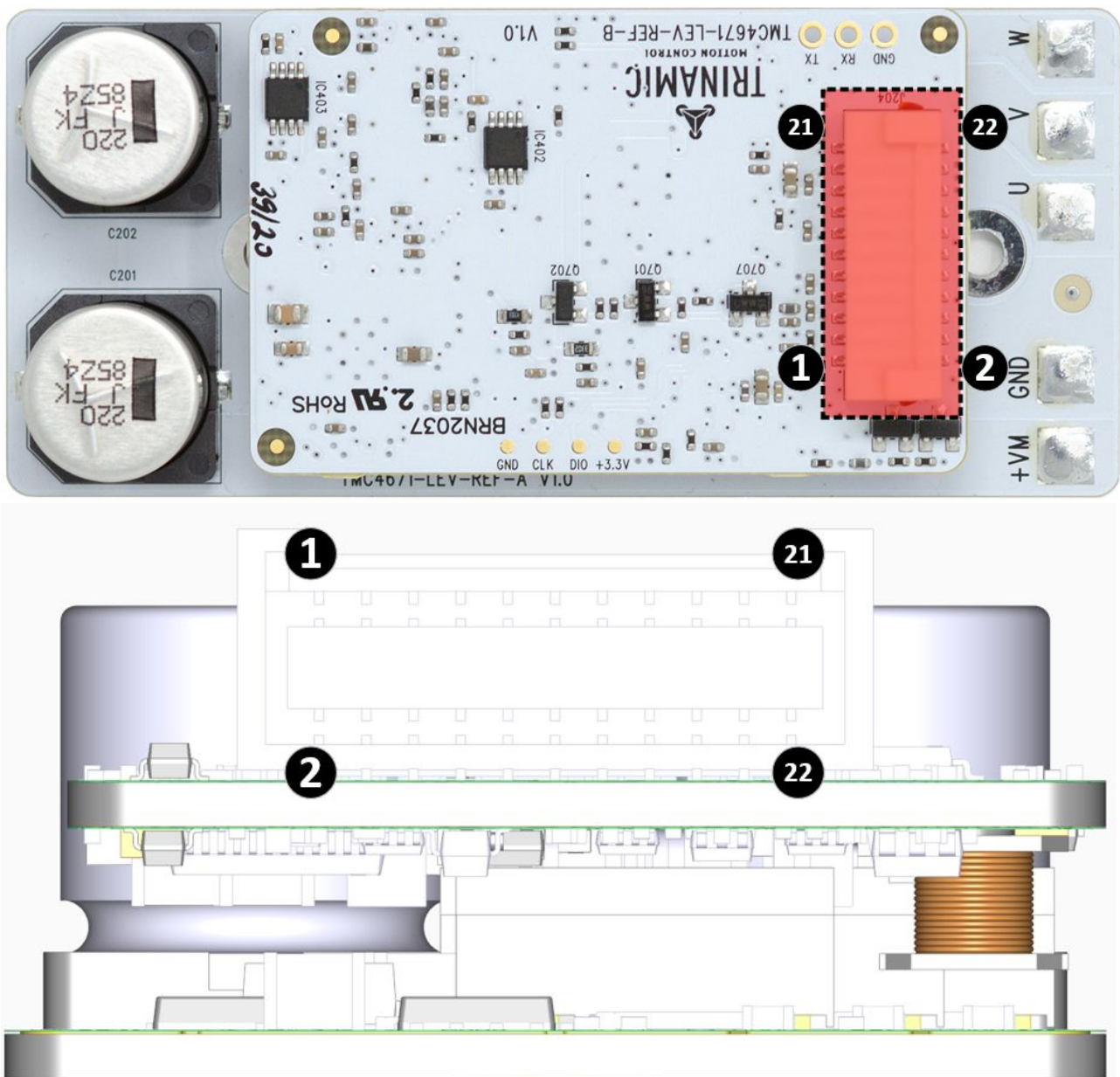

Figure 4: TMC4671-LEV-REF I/O connector

Pin #	Signal / Label	Description	Range [Units]	Units
1	+6V_REAR	+6V/2A supply for external lights, 2A together with +6V_FRONT	6	V
2	GND	Supply ground		
3	+6V_FRONT	+6V/2A supply for external lights, 2A together with +6V_REAR	6	V
4	GND	Supply ground		
5	CAN_H	CAN bus signal, with line protection		
6	GND	Supply ground		
7	CAN_L	CAN bus signal, with line protection		
8	+12V	+12V/0.5A supply for external peripherals like torque sensor	12	V
9	SIN_5V	External torque sensor input, internal 4k7 pull-up to 5V, Clamping diodes to +5V and GND, Low-pass filter: 100Ω and 100pF	0...5	V
10	GND	Supply ground		
11	COS_5V	External torque sensor input, internal 4k7 pull-up to 5V, Clamping diodes to +5V and GND, Low-pass filter: 100Ω and 100pF	0...5	V
12	TORQUE_5V	External torque sensor input, Clamping diodes to +5V and GND, Voltage divider 1k and 2.2k	0...5	V
13	BUTTON	External button or control input, internal 4k7 pull-up to 3.3V, Low-pass filter: 1kΩ and 100nF, Clamping diodes to +3.3V and GND	0...3.3	V
14	GND	Supply ground		
15	LED_GREEN	External PWM control for an LED, triple non-inverting Schmitt-triggers for 3x 24mA drive/sink, Clamping diodes to +3.3V and GND	0...3.3	V
16	LED_RED	External PWM control for an LED, triple non-inverting Schmitt-triggers for 3x 24mA drive/sink, Clamping diodes to +3.3V and GND	0...3.3	V
17	+5V	+5V/100mA supply for external peripherals like HALL sensor	5	V
18	GND	Supply ground		



Pin #	Signal / Label	Description	Range [Units]	Units
19	SPEED_5V	External speed sensor input, internal 4k7 pull-up to 5V, Clamping diodes to +5V and GND, Low-pass filter: 100Ω and 100pF	0...5	V
20	HALL_U_5V	Hall sensor input phase U, internal 4k7 pull-up to 5V, Clamping diodes to +5V and GND, Low-pass filter: 100Ω and 100pF	0...5	V
21	HALL_V_5V	Hall sensor input phase U, internal 4k7 pull-up to 5V, Clamping diodes to +5V and GND, Low-pass filter: 100Ω and 100pF	0...5	V
22	HALL_W_5V	Hall sensor input phase U, internal 4k7 pull-up to 5V, Clamping diodes to +5V and GND, Low-pass filter: 100Ω and 100pF	0...5	V



4.3 Optional UART Header

These connections are mounting holes for standard 0.1" (2.54mm) pitch headers to connect to the controller via a standard digital UART interface. Signal levels are 3.3V and connect directly to the onboard MCU.

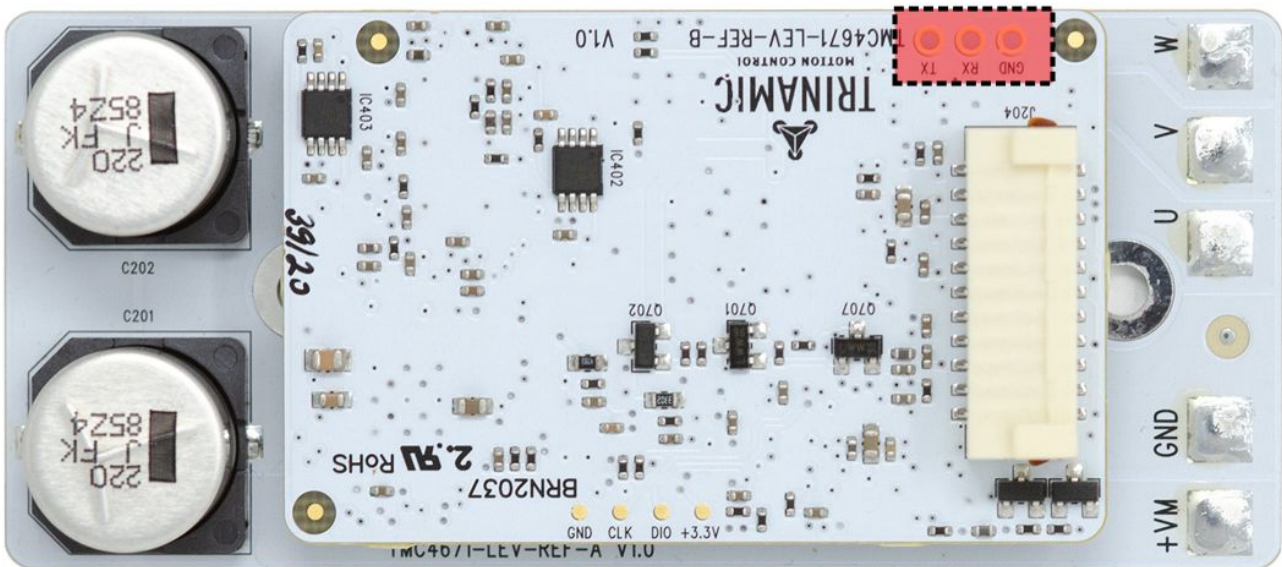

Figure 5: TMC4671-LEV-REF optional UART header

Pin #	Signal / Label	Description	Range [Units]	Units
-	GND	Supply ground		
-	RX	Input, TTL UART Receive line	3.3	V
-	TX	Output, TTL UART Transmit line	3.3	V

4.4 SWD Programming Pads

In Figure 5 at the bottom edge of the board the SWD programming pads for the modules internal can be seen. There are 4 pads.

- +3.3V - VCCIO
- DIO - SWD IO line (at 3.3V level)
- CLK - SWD clock line (at 3.3V level)
- GND - Ground



5 Firmware Description

5.1 TMCL Protocol

5.1.1 Binary Request Format

The TMCL protocol bases on a simple request/reply principle. The request is also called command, as it contains the command to be executed.

Every command has a mnemonic and a binary representation. When commands are sent from a host to a module, the binary format has to be used. Every command consists of a one-byte command field, a one-byte type field, a one-byte motor/bank field and a four-byte value field. So the binary representation of a command always has seven bytes. When a command is to be sent, it has to be enclosed by an address byte at the beginning and a checksum byte at the end. Thus the complete request consists of nine bytes.

The binary command format is as follows:

TMCL Command Format	
Bytes	Meaning
1	Module address
1	Command number
1	Type number
1	Motor or Bank number
4	Value (MSB first!)
1	Checksum

Table 5: TMCL Command Format

The checksum is calculated by adding up all bytes (including the module address byte) using 8-bit addition as shown in this C code example:

```

1 unsigned char i, Checksum;
  unsigned char Command[9];
3
  //Set the Command array to the desired command
5 Checksum = Command[0];
  for(i=1; i<8; i++)
7     Checksum+=Command[i];
9
  Command[8]=Checksum; //insert checksum as last byte of the command
  //Now, send it to the module

```

5.1.2 Binary Reply Format

Every time a command has been sent to a module, the module sends a reply. The reply is also 9 byte long and formatted is as follows:



TMCL Reply Format	
Bytes	Meaning
1	Reply address
1	Module address
1	Status (e.g. 100 means no error)
1	Command number
4	Value (MSB first!)
1	Checksum

Table 6: TMCL Reply Format

The reply contains a status code. The status code can have one of the following values:

TMCL Status Codes	
Code	Meaning
100	Successfully executed, no error
1	Wrong checksum
2	Invalid command
3	Wrong type
4	Invalid value
5	Configuration EEPROM locked
6	Command not available

Table 7: TMCL Status Codes

5.2 Open Source Firmware Project

5.2.1 Introduction

Trinamic provides an open source project as a starting point for own software development or adaptation. The firmware project for TMC4671-LEV-REF is hosted on GitHub:

<https://github.com/trinamic/TMC4671-LEV-REF>.

5.2.2 Boot Loader

The software consists of a boot loader and the actual firmware. The TMC4671-LEV-REF comes shipped with boot loader and firmware preprogrammed. With the help of the boot loader, the firmware can be updated by the user over the TMCL protocol. Please note that the boot loader is only available as binary image. The image can be found in the git repository under the *bootloader* directory. When the boot loader is active both red and green state LEDs are flashing.



5.2.3 Software Functions

The Firmware supports the TMCL protocol described in section 5.1. The TMCL interpreter on the module will interpret received commands, read inputs and write outputs or whatever is necessary according to the specified command. And as soon as this step has been done, the module will send a reply back over the interface to the sender of the command. No new command should be send until the reply of the last command was received.

Changed settings can be stored in a non-volatile memory via the STAP (5.2.4.3) command.

5.2.4 Supported TMCL Commands

This section gives a short overview of the available TMCL commands.

5.2.4.1 SAP (Set Axis Parameter)

With this command most of the parameters of the module can be specified. The settings will be stored in SRAM and therefore are volatile. Thus, information will be lost after power off. For a table with parameters and values which can be used together with this command please refer to section 5.2.5.

Internal function: The specified value is written to the axis parameter specified by the type number.

Related commands: GAP

Mnemonic: SAP <type number>, <axis>, <value>

Binary representation:

Binary Representation			
Instruction	Type	Motor/Bank	Value
5	see chapter 5.2.5	0	<value>

Example Set axis parameter 96. (*Mnemonic:* SAP 96, 0, 500)

Binary Form of SAP 96, 0, 241	
Field	Value
Target address	01 _h
Instruction number	05 _h
Type	60 _h
Motor/Bank	00 _h
Value (Byte 3)	00 _h
Value (Byte 2)	00 _h
Value (Byte 1)	00 _h
Value (Byte 0)	F1 _h
Checksum	57 _h



5.2.4.2 GAP (Get Axis Parameter)

Most parameters of the TMC4671-LEV-REF can be adjusted using e.g. the SAP command. With the GAP parameter they can be read out. For a table with type numbers and values that can be used together with this command please refer to section 5.2.5.

Internal function: The specified value gets copied to the accumulator.

Related commands: SAP

Mnemonic: GAP <type number>, <axis>

Binary representation:

Binary Representation			
Instruction	Type	Motor/Bank	Value
6	see chapter 5.2.5	0	<value>

Example Get the axis parameter 96. (*Mnemonic:* GAP 96, 0)

Binary Form of GAP 96, 0	
Field	Value
Target address	01 _h
Instruction number	06 _h
Type	60 _h
Motor/Bank	00 _h
Value (Byte 3)	00 _h
Value (Byte 2)	00 _h
Value (Byte 1)	00 _h
Value (Byte 0)	00 _h
Checksum	67 _h

5.2.4.3 STAP (Store Axis Parameter)

This command is used to store TMCL axis parameters permanently in the EEPROM of the module. This command is mainly needed to store the default configuration of the module. For a table with type numbers and values which can be used together with this command please refer to section 5.2.5.

Internal function: The axis parameter specified by the type and bank number will be stored in the EEPROM.

Related commands: SAP, GAP, RSAP.

Mnemonic: STAP <type number>, <bank>

Binary representation:



Binary Representation			
Instruction	Type	Motor/Bank	Value
7	see chapter 5.2.5	0	0 (don't care)

Example Store axis parameter 96. (*Mnemonic:* STAP 96, 0)

Binary Form of STAP 96, 0	
Field	Value
Target address	01 _h
Instruction number	07 _h
Type	60 _h
Motor/Bank	00 _h
Value (Byte 3)	00 _h
Value (Byte 2)	00 _h
Value (Byte 1)	00 _h
Value (Byte 0)	00 _h
Checksum	68 _h

5.2.4.4 RSAP (Restore Axis Parameter)

With this command the content of an axis parameter can be restored from the EEPROM. By default, all axis parameters are automatically restored after power up. An axis parameter that has been changed before can be reset to the stored value by this instruction. For a table with type numbers and values which can be used together with this command please refer to section 5.2.5.

Internal function: The axis parameter specified by the type and bank number will be restored from the EEPROM.

Related commands: SAP, GAP, STAP

Mnemonic: RSAP <parameter number>, <bank>

Binary representation:

Binary Representation			
Instruction	Type	Motor/Bank	Value
8	see chapter 5.2.5	0	0 (don't care)

Example Restore axis parameter 96. (*Mnemonic:* RSAP 96, 0)



Binary Form of RSAP 96, 0	
Field	Value
Target address	01 _h
Instruction number	08 _h
Type	60 _h
Motor/Bank	00 _h
Value (Byte 3)	00 _h
Value (Byte 2)	00 _h
Value (Byte 1)	00 _h
Value (Byte 0)	00 _h
Checksum	69 _h



5.2.5 Axis Parameters

Axis parameters are accessed with the GAP and SAP command.

Axis 0 Parameters of the TMC4671-LEV-REF Module					
Number	Axis Parameter	Description	Range [Units]	Default	Access
5	adc_i0_offset	Manually set/get the dual-shunt phase_A offset.	0 ... 65535	32767	RWEX
6	adc_i1_offset	Manually set/get the dual-shunt phase_B offset.	0 ... 65535	32767	RWEX
7	adc_i0	Calculated current measurement for phase_A shunt and used offset	-32768 ... 32767	0	R
8	adc_i1	Calculated current measurement for phase_B shunt and used offset	-32768 ... 32767	0	R
9	adc_i2	Calculated current of phase_C from phase_A and phase_B measurements	-32768 ... 32767	0	R
10	dual shunt factor	Manually adjust the dual shunt current measurement factor.	1 ... 65535	256	RWEX
12	open loop current	Motor current for controlled commutation. This parameter is used in commutation mode 1.	0 ... 30000 [mA]	2000	RWEX
14	motor type	Select your motor type. 3 - Three phase BLDC	3 ... 3	0	R
15	commutation mode	Select a commutation mode that fits best to your motor's sensors. 0 - FOC - disabled 1 - FOC - open_loop 2 - FOC - digital_hall 3 - FOC - digital_hall - Pedal_controlled	0 ... 3	0	RWEX
16	open loop commutation angle	Actual controlled angle value.	-32768 ... 32767	0	R
18	hall commutation angle	Actual hall angle value.	-32768 ... 32767	0	R
20	torque P	P parameter for current PID regulator	0 ... 32767	0	RWEX
21	torque I	I parameter for current PID regulator	0 ... 32767	0	RWEX
22	velocity P	P parameter for velocity PID regulator	0 ... 32767	0	RWEX
23	velocity I	I parameter for velocity PID regulator	0 ... 32767	0	RWEX



Number	Axis Parameter	Description	Range [Units]	Default	Access
30	target torque	Get desired target current or set target current to activate current regulation mode. (+= turn motor in right direction; -= turn motor in left direction)	-30000 ... 30000 [mA]	0	RW
31	actual torque	The actual motor current.	-2147483648 ... 2147483647 [mA]	0	R
40	target velocity	The desired target velocity.	-200000 ... 200000 [rpm]	0	RW
41	ramp velocity	The actual velocity of the velocity ramp used for positioning and velocity mode.	-2147483648 ... 2147483647 [rpm]	0	R
42	actual velocity	The actual velocity of the motor.	-2147483648 ... 2147483647 [rpm]	0	R
43	max velocity	Max. absolute velocity for velocity and positioning mode.	0 ... 200000 [rpm]	4000	RWEX
44	acceleration	Acceleration parameter for ROL, ROR, and the velocity ramp of MVP.	0 ... 100000 [rpm/s]	2000	RWEX
45	enable velocity ramp	An activated ramp allows a defined acceleration for velocity and position mode. 0 - Deactivate velocity ramp generator. 1 - Activate velocity ramp generator.	0 ... 1	1	RWEX
50	pedal pulses per rotation	Pulses per cycle	0 ... 65535 [INCR]	32	RWEX
52	pedal sense delay	Pedal position pulses motor is set active, in order to prevent false support.	0 ... 65535 [RPM]	1	RWEX
53	torque sensor gain		-32768 ... 32768	800	RWEX
54	torque sensor offset	Calibrate the Torque Sensor	0 ... 65535	2500	RWEX
55	torque dead band	Threshold before torque input is considered valid.	0 ... 65535	500	RWEX
56	assist cut out distance	Distance to turn off the motor support after ending pedaling.	0 ... 65535 [m]	1	RWEX
57	initial right torque	The default torque while starting with the right leg.	0 ... 65535	200	RWEX
58	initial right torque speed	Limit the impact of the initial Right Torque parameter in regard to speed.	0 ... 10 [km/h]	3	RWEX



Number	Axis Parameter	Description	Range [Units]	Default	Access
60	left/right ratio	Impact of the left or right leg	0 ... 100 [%]	50	RWEX
61	average/sport mode	0%: use average of sensor values of sensor values 100%: use sensor values directly	0 ... 100 [%]	50	RWEX
65	pedal direction		-1 ... 1	0	R
66	pedal motor enable	0 - disabled 1 - enabled	0 ... 1	0	R
67	average torque	Average measured torque	-32768 ... 32768 [Nm]	0	R
70	positive motoring ramp time	increase torque	0 ... 65535 [mA/s]	20000	RWEX
71	negative motoring ramp time	decrease torque	0 ... 65535 [mA/s]	30000	RWEX
73	speed 0	Speed 0 correlates Torque 0	0 ... 35 [km/h]	0	RWEX
74	speed 1	Speed 1 correlates Torque 1	0 ... 35 [km/h]	0	RWEX
75	speed 2	Speed 2 correlates Torque 2	0 ... 35 [km/h]	0	RWEX
76	speed 3	Speed 3 correlates Torque 3	0 ... 35 [km/h]	0	RWEX
77	speed 4	Speed 4 correlates Torque 4	0 ... 35 [km/h]	0	RWEX
78	speed 5	Speed 5 correlates Torque 5	0 ... 35 [km/h]	0	RWEX
79	speed 6	Speed 6 correlates Torque 6	0 ... 35 [km/h]	0	RWEX
80	speed 7	Speed 7 correlates Torque 7	0 ... 35 [km/h]	0	RWEX
81	speed 8	Speed 8 correlates Torque 8	0 ... 40 [km/h]	0	RWEX
82	torque 0	Torque 0 correlates Speed 0	0 ... 100 [%]	0	RWEX
83	torque 1	Torque 1 correlates Speed 1	0 ... 100 [%]	0	RWEX
84	torque 2	Torque 2 correlates Speed 2	0 ... 100 [%]	0	RWEX
85	torque 3	Torque 3 correlates Speed 3	0 ... 100 [%]	0	RWEX
86	torque 4	Torque 4 correlates Speed 4	0 ... 100 [%]	0	RWEX
87	torque 5	Torque 5 correlates Speed 5	0 ... 100 [%]	0	RWEX
88	torque 6	Torque 6 correlates Speed 6	0 ... 100 [%]	0	RWEX
89	torque 7	Torque 7 correlates Speed 7	0 ... 100 [%]	0	RWEX
90	torque 8	Torque 8 correlates Speed 8	0 ... 100 [%]	0	RWEX
91	maximum speed	Limit the maximum supported bike speed	0 ... 40 [km/h]	25	RWEX



Number	Axis Parameter	Description	Range [Units]	Default	Access
92	actual torque/speed map	Actual value of the TorqueSpeed Map dependant to the bike speed.	0 ... 30000 [mA]	0	R
93	actual gain		0 ... 255 [%]	0	R
94	actual torque limit	Actual torque limit in regards to power/speed map and maximum speed. 0 - 1 -	0 ... 1	0	RWEX
100	maximum current	Max. allowed absolute motor current. *This value can be temporarily exceeded marginal due to the operation of the current regulator.	0 ... 30000 [mA(RMS)]	23000	RWEX
101	pole pairs	Number of motor pole pairs.	0 ... 255	8	RWEX
102	gear ratio	Reduction Ratio	0 ... 255 [N:1]	1	RWEX
103	wheel diameter	wheel Diameter	0 ... 65535 [mm]	700	RWEX
104	wheel pulses per rotation	Pulses per Cycle	0 ... 255 [mm]	1	RWEX
105	hall offset		-32768 ... 32768 [INCR]	0	RWEX
106	hall polarity	0 - Hall Polarity bit is not set 1 - Hall Polarity bit is set	0 ... 1	0	RWEX
107	hall interpolation	0 - Hall Interpolation Off 1 - Hall Interpolation On	0 ... 1	0	RWEX
108	hall direction	0 - Hall Direction bit is not set. 1 - Hall Direction bit is set.	0 ... 1	0	RWEX
110	current regulator bandwidth		20 ... 200 [kHz]	20	RWEX
111	minimum motor current		0 ... 65535 [mA(RMS)]	100	RWEX
114	swap motor A and C phase	0 - 1 -	0 ... 1	0	RWEX
115	motor test modes	0 - disabled 1 - enabled	0 ... 1	0	RWEX
116	actual motor speed		0 ... 65535 [rpm]	0	R



Number	Axis Parameter	Description	Range [Units]	Default	Access
117	actual bike speed		0 ... 65535 [m/s]	0	R
118	actual bike speed		0 ... 65535 [km/h]	0	R
130	min battery voltage		12 ... 60 [V]	0	RWEX
131	max battery voltage		12 ... 60 [V]	0	RWEX
132	cut off voltage		12 ... 60 [V]	0	RWEX
133	battery-saving timer		0 ... 60000 [s]	0	RWEX
220	supply voltage	The actual supply voltage.	0 ... 1000 [100mV]	480	R
222	status flags	Actual status flags.	0 ... 0	0	R
223	input 12V	The actual Input 12V.	0 ... 1000 [100mV]	120	R
224	input 6V	The actual Input 6V.	0 ... 1000 [100mV]	60	R
225	input 5V	The actual Input 5V.	0 ... 1000 [100mV]	50	R
226	pedal torque actual		0 ... 4095	0	R
227	left pedal torque		0 ... 65535	0	R
228	right pedal torque		0 ... 65535	0	R
229	target pedal torque		0 ... 65535	0	R
230	main loops	Main loops per second.	0 ... 4294967295	0	R
231	torque loops	Torque loops per second.	0 ... 4294967295	0	R
232	velocity loops	Velocity loops per second.	0 ... 4294967295	0	R
233	pedal counter		-2147483648 ... 2147483647	0	R
234	pedal position		0 ... 32	0	R
235	pedal counts per second		-1000 ... 1000 [500ms]	0	R
236	pedal velocity		-1000 ... 1000 [rpm]	0	R
237	filtered pedal velocity		0 ... 65535 [rpm]	0	R



Number	Axis Parameter	Description	Range [Units]	Default	Access
238	filtered pedal velocity fast		0 ... 65535 [rpm]	0	R
240	debug value 0	Free used debugging value.	-2147483648 ...2147483647	0	RW
241	debug value 1	Free used debugging value.	-2147483648 ...2147483647	0	RW
242	debug value 2	Free used debugging value.	-2147483648 ...2147483647	0	RW
243	debug value 3	Free used debugging value.	-2147483648 ...2147483647	0	RW
244	debug value 4	Free used debugging value.	-2147483648 ...2147483647	0	RW
245	debug value 5	Free used debugging value.	-2147483648 ...2147483647	0	RW
246	debug value 6	Free used debugging value.	-2147483648 ...2147483647	0	RW
247	debug value 7	Free used debugging value.	-2147483648 ...2147483647	0	RW
248	debug value 8	Free used debugging value.	-2147483648 ...2147483647	0	RW
249	debug value 9	Free used debugging value.	-2147483648 ...2147483647	0	RW
255	enable driver	Enables the motor driver (enabled by default) 0 - driver disabled 1 - driver enabled	0 ... 1	1	RW

Table 8: All TMC4671-LEV-REF Axis 0 Parameters

The access abbreviations means R for readonly, RW for read/write, and RWE for read/write/storeable in EEPROM for direct use after next reboot.

5.2.6 Using the TMCL-IDE with the Board

During development the TMCL-IDE can be very helpful. All axis parameter can be read, written and live plotted. Especially to find the right motor parameters this helps a lot. In addition, the firmware can be updated.

5.3 Writing your own Firmware

You are free to write your own firmware for the TMC4671-LEV-REF. Flashing and debugging of the MCU can be done via the Serial Wire Debug Interface (SWD). Figure 5 shows the location of the SWD programming pads.



6 Operational Ratings and Characteristics

6.1 Absolute Maximum Ratings

Parameter	Symbol	Min	Max	Unit
Supply voltage	$+VM$	+12	+55	V
Abs. max. RMS motor phase current	$I_{phase,RMS}$		25 ¹	A
Working temperature	T_A	-10	+60 ²	°C
Max current at +12V_OUT	$I_{OUT+12V,MAX}$		500	mA
Max current at +6V_OUT	$I_{OUT+6V,MAX}$		2000	mA
Max current at +5V_OUT	$I_{OUT+5V,MAX}$		100	mA

NOTICE

Never exceed the absolute maximum ratings! Stresses above those listed under "Absolute Maximum Ratings" may cause permanent damage to the device. This is a stress rating only and functional operation of the device at those or any other conditions above those indicated in the operation listings of this specification is not implied. Exposure to maximum rating conditions for extended periods may affect device reliability.

6.2 Electrical Characteristics (Ambient Temperature 25°C)

Parameter	Symbol	Min	Typ	Max	Unit
Supply voltage	V_{DD}	+12	+48	+52	V
continuous RMS motor phase current	$I_{phase,RMS}$			12	A

Table 10: Electrical Characteristics

6.3 I/O Ratings (Ambient Temperature 25°C)

Parameter	Symbol	Min	Typ	Max	Unit
Input voltage for HALL and analog inputs	V_{AIN}	0		5.0	V
BUTTON control input voltage	V_{GPI}	0		3.3	V
LED control outputs voltage	V_{GPO}	0		3.3	V

Table 11: I/O ratings

¹ This is the maximum current rating. This is not for continuous operation but depends on motor type, duty cycle, ambient temperature, and active/passive cooling measures.

² Working at high environmental temperatures may require additional cooling measures depending on duty cycle and maximum current/power draw.



6.4 Other Requirements

Specifications	Description or Value
Cooling	Free air or heat sink mounted with isolating gap pad
Working environment	Avoid dust, water, oil mist and corrosive gases, no condensation, no frosting

Table 12: Other Requirements and Characteristics



7 Figures Index

1	LEV Reference Design with Controller and Driver Board	4	3	TMC4671-LEV-REF motor and power connectors	7
2	TMC4671-LEV-REF top view mechanical dimensions	6	4	TMC4671-LEV-REF I/O connector	8
			5	TMC4671-LEV-REF optional UART header	11



8 Tables Index

1	Order codes	5	11	I/O ratings	24
5	TMCL Command Format	12	12	Other Requirements and Characteristics	25
6	TMCL Reply Format	13	13	Hardware Revision	30
7	TMCL Status Codes	13	14	Firmware Revision	30
8	All TMC4671-LEV-REF Axis 0 Parameters	23	15	Document Revision	30
10	Electrical Characteristics	24			



9 Supplemental Directives

9.1 Producer Information

9.2 Copyright

TRINAMIC owns the content of this user manual in its entirety, including but not limited to pictures, logos, trademarks, and resources. © Copyright 2021 TRINAMIC. All rights reserved. Electronically published by TRINAMIC, Germany.

Redistributions of source or derived format (for example, Portable Document Format or Hypertext Markup Language) must retain the above copyright notice, and the complete Datasheet User Manual documentation of this product including associated Application Notes; and a reference to other available product-related documentation.

9.3 Trademark Designations and Symbols

Trademark designations and symbols used in this documentation indicate that a product or feature is owned and registered as trademark and/or patent either by TRINAMIC or by other manufacturers, whose products are used or referred to in combination with TRINAMIC's products and TRINAMIC's product documentation.

This HW & FW Manual is a non-commercial publication that seeks to provide concise scientific and technical user information to the target user. Thus, trademark designations and symbols are only entered in the Short Spec of this document that introduces the product at a quick glance. The trademark designation /symbol is also entered when the product or feature name occurs for the first time in the document. All trademarks and brand names used are property of their respective owners.

9.4 Target User

The documentation provided here, is for programmers and engineers only, who are equipped with the necessary skills and have been trained to work with this type of product.

The Target User knows how to responsibly make use of this product without causing harm to himself or others, and without causing damage to systems or devices, in which the user incorporates the product.

9.5 Disclaimer: Life Support Systems

TRINAMIC Motion Control GmbH & Co. KG does not authorize or warrant any of its products for use in life support systems, without the specific written consent of TRINAMIC Motion Control GmbH & Co. KG.

Life support systems are equipment intended to support or sustain life, and whose failure to perform, when properly used in accordance with instructions provided, can be reasonably expected to result in personal injury or death.

Information given in this document is believed to be accurate and reliable. However, no responsibility is assumed for the consequences of its use nor for any infringement of patents or other rights of third parties which may result from its use. Specifications are subject to change without notice.

9.6 Disclaimer: Intended Use

The data specified in this user manual is intended solely for the purpose of product description. No representations or warranties, either express or implied, of merchantability, fitness for a particular purpose



or of any other nature are made hereunder with respect to information/specification or the products to which information refers and no guarantee with respect to compliance to the intended use is given.

In particular, this also applies to the stated possible applications or areas of applications of the product. TRINAMIC products are not designed for and must not be used in connection with any applications where the failure of such products would reasonably be expected to result in significant personal injury or death (safety-Critical Applications) without TRINAMIC's specific written consent.

TRINAMIC products are not designed nor intended for use in military or aerospace applications or environments or in automotive applications unless specifically designated for such use by TRINAMIC. TRINAMIC conveys no patent, copyright, mask work right or other trade mark right to this product. TRINAMIC assumes no liability for any patent and/or other trade mark rights of a third party resulting from processing or handling of the product and/or any other use of the product.

9.7 Collateral Documents & Tools

This product documentation is related and/or associated with additional tool kits, firmware and other items, as provided on the product page at: www.trinamic.com.



10 Revision History

10.1 Hardware Revision

Version	Date	Author	Description
1.00	02.09.2020	MM	Launch release.

Table 13: Hardware Revision

10.2 Firmware Revision

Version	Date	Author	Description
1.00	23.11.2020	ED	Launch release.

Table 14: Firmware Revision

10.3 Document Revision

Version	Date	Author	Description
1.00	15.01.2021	SK/ED	Launch release.

Table 15: Document Revision

