

ATLANTIC VERSION TERMINATOR INTERFACE ADAPTER	PART NUMBER	REVISION	DESCRIPTION	FEED TYPE	CONVERT TO	PART NUMBERS REQUIRED					
	2150354-1	B	FINE CRIMP HEIGHT ADJUST	MECHANICAL	PNEUMATIC FEED	2119950-1	2119792-2	-	2119641-1	-	2063440-1
					SERVO LATCH PLATE	2119951-1	1901697-1	8-2150354-5	-	-	2168400-7 (QUANTITY 2)
					SMART APPLICATOR	2161326-1	-	8-2150354-4	-	-	-
	2150354-2	B	FINE CRIMP HEIGHT ADJUST	PNEUMATIC	MECHANICAL FEED	2119949-1	2063961-1	5-18022-5	2119653-1	-	-
					SERVO LATCH PLATE	2119951-1	1901697-1	8-2150354-5	-	-	2168400-7 (QUANTITY 2)
					SMART APPLICATOR	2161326-1	-	8-2150354-4	-	-	-
	2150354-5	B	FINE CRIMP HEIGHT ADJUST	SERVO LATCH PLATE ⁴	MECHANICAL FEED	2119949-1	2063961-1	5-18022-5	2119653-1	-	-
2150354-6	B	NON-CRIMP HEIGHT ADJUST	SERVO LATCH PLATE ⁴	PNEUMATIC FEED	2119950-1	2119792-2	-	2119641-1	-	2063440-1	
2150354-7	B	FINE CRIMP HEIGHT ADJUST	NONE	-	-	-	-	-	-	-	
7-2150354-7	A	CRIMP TOOLING KIT	-	-	-	-	-	-	-	-	

APPLICATOR DATA		
CRIMP SIZE	TYPE	
WIRE 2.02 mm [.080]	F	
INSUL -	-	

APPLICATOR INSTRUCTIONS 408-10390

TERMINAL DATA: GMG TERMINAL TE CRIMP SPECIFICATION			
TERMINAL NAME: TERMINAL			
WIRE STRIP LENGTH		INSULATION DIAMETER RANGE	
6.96-7.96 mm [.274-.313 IN]		-	
TERMINAL APPLICATION SPECIFICATION	NONE	-	-
TERMINALS APPLIED ¹³			
TE TERMINAL	GMG TERMINAL	TE TERMINAL	GMG TERMINAL
2113361-1	33000.51.001	2113361-3	33000.04.001
2113361-2	33000.51.081		

WIRE SIZE	CRIMP HEIGHT mm [INCH]	CRIMP HEIGHT REFERENCE SETTING ⁹
1.50mm2	1.40+/-0.05 [.055+/- .002]	7.4
1.00mm2	1.24+/-0.05 [.049+/- .002]	9.5
0.75mm2	1.14+/-0.05 [.045+/- .002]	10.7
0.50mm2	1.04+/-0.05 [.041+/- .002]	11.8

- ¹ RECOMMENDED SPARE PARTS
- ² GREASE BEARING SURFACES LIGHTLY
- 3. LUBRICATE DAILY PER THE APPLICATOR INSTRUCTION SHEET SUPPLIED WITH THE APPLICATOR.
- ⁴ APPLICATOR SPECIFIC DATA TO BE ENTERED INTO BLANK MEMORY CHIP AT ASSEMBLY. SEE BELOW FOR PART NUMBER:
 MECHANICAL FEED WITH "SMART APPLICATOR" CONVERSION: 8-2150354-4
 PNEUMATIC FEED WITH "SMART APPLICATOR" CONVERSION: 8-2150354-4
 SERVO FEED WITH "FINE CRIMP HEIGHT ADJUST": 8-2150354-5
 SERVO FEED WITH "NON-CRIMP HEIGHT ADJUST": 8-2150354-6
- 5. ADJUSTMENT OF THE STRIPPER MAY BE REQUIRED WHEN MOVING THE APPLICATOR BETWEEN BENCH AND LEADMAKER APPLICATIONS.
- ⁶ APPLY PART NUMBER 1-23419-5 LOCTITE TO THREADS OF ITEM 62. FOR -6 ONLY, APPLY PART NUMBER 1-23419-5 LOCTITE TO THREADS OF ITEM 37.
- ⁷ GREASE THREADS, GROOVE AND O-RING ON ITEMS 35 & 252.
- ⁸ MAGNET, ITEM 166 MUST BE ORIENTED CORRECTLY IN ORDER TO PROPERLY ACTUATE THE COUNTER.
- ⁹ CRIMP HEIGHT REFERENCE SETTING WAS THE SETTING USED WHEN THE APPLICATOR WAS QUALIFIED AT THE FACTORY. ADJUSTMENT MAY BE NECESSARY WHEN RUNNING APPLICATOR IN THE FIELD.
- ¹⁰ SPARE FEED CAM STORAGE LOCATION REFER TO INSTRUCTION SHEET FOR ADDITIONAL INFORMATION.
- ¹¹ THE RECOMMENDED SET-UP FOR END FEED APPLICATORS IS POST-FEED WITH ITEM 2119653-1. THE APPLICATOR CAN BE CONFIGURED FOR PRE-FEED WITH ITEM 2119652-1 BUT MAY ENCOUNTER PROBLEMS WITH SOME APPLICATIONS. FEED ISSUES OR TERMINAL JAMMING MAY OCCUR IN THE PRE-FEED CONFIGURATION.
- ¹² WHEN ASSEMBLING -6 NON-CRIMP HEIGHT ADJUST APPLICATOR USE SHIM PACK 2119957-2 TO ALIGN APPLICATOR'S MAXIMUM WIRE CRIMP HEIGHT AT NORMAL TERMINATOR SHUT HEIGHT.
- ¹³ TERMINAL LUBRICANT IS RECOMMENDED.

***WARNING**
 ON INSTALLATION, SET WIRE DISC, ITEM 40 TO LARGEST WIRE SIZE SETTING. USE OF SETTINGS BELOW MINIMUM REQUIRED CRIMP HEIGHT SETTING WILL CAUSE DAMAGE TO CRIMP TOOLING.

ATLANTIC VERSION
 Shown on sheets 1 of 4 & 2 of 4
 (Pacific version shown on sheets 3 of 4 & 4 of 4)

SET UP GAUGE	LOC	DIST	REVISIONS			
2119599-2	A	66	REV	DATE	BY	APPV
			A	RELEASED	05NOV2013	KS TE
			B	REVISED ECR-14-000409	14JAN2014	KH GB

-	1	1	1	1	1	2119955-2	ASSY, LUBRICATOR, END FEED	261
-	-	1	-	-	-	2119957-2	APPLICATOR SHIM PACK	260
-	1	-	1	1	1	8-21084-0	O-RING, .676 ID, .070 DIA. MAT.	252
-	-	-	-	1	-	2119640-1	PUSH ROD, AIR FEED	250
-	-	-	-	1	-	2079988-1	BUSHING, LCH5-12, MISUMI	249
-	-	-	-	1	-	2119641-1	FEED CAM, AIR FEED	248
-	1	-	1	1	1	2119798-1	DETENT PIN	247
-	1	-	1	1	1	1-22279-3	SPRING, COMPRESSION	246
-	-	1	-	-	-	2161315-1	RAM, STEPPED, AMP STYLE, END FEED, NON-ADJUST	245
-	-	2	2	-	-	2168400-7	SHCS, LOW HEAD, RoHS, M5 X 10	240
-	-	-	-	-	1	2119580-1	MECHANICAL FEED ASSEMBLY	239
-	-	-	-	1	-	2063440-1	AIR FEED MODULE	238
-	-	1	1	-	-	2119740-2	TAG, IDENTIFICATION	213
-	-	REFREF	-	-	-	1901697-1	FEED FINGER ASSEMBLY, EF	183
-	-	-	-	2	-	21045-3	RING, RETAIN, EXTERN, 3/16 CRESCENT	172
-	1	1	1	1	1	994969-1	MAGNET, RARE EARTH HIGH ENERGY	166
-	REFREF	REFREF	REFREF	REFREF	REFREF	994970-2	COUNTER, MAGNETIC	164
-	-	-	-	1	-	240638-1	SPRING, FEED FINGER	163
-	-	-	-	1	-	3-23627-7	PIN, RETAIN, GRVD, 3/16 X .854	137
-	-	REFREF	-	-	-	SEE NOTE 4	MEMORY CHIP, PROGRAMMED	135
-	-	1	1	-	-	1633743-1	SERVO FEED LATCH ASM	133
-	1	1	1	1	1	1-455888-1	SPACER, CRIMPER	82
-	1	1	1	1	1	2119956-2	DOCUMENTATION PACKAGE	71
-	2	2	2	2	2	2-18032-2	SCR, SET, FLT POINT M3 X 10.0	70
-	1	-	-	1	1	2119740-1	TAG, IDENTIFICATION	67
-	2	2	2	2	2	2168078-1	SCREW, DRIVE, RH, RoHS, 2 x .188	66
-	2	2	2	2	2	2168400-5	SHCS, LOW HEAD, RoHS, M4 X 20	64
-	1	-	1	1	1	2119793-1	LIMITER, ADJUSTMENT BOLT	63
-	3	-	3	3	3	992763-5	SCR, SET, SOC, CONE POINT, M3 X 4.0	62
-	-	-	-	-	1	5-18022-5	SCR, HEX HD CAP, M4 X 6.0	59
-	-	-	-	-	1	2063961-1	FEED FINGER	58
-	3	3	3	3	3	2168400-4	SHCS, LOW HEAD, RoHS, M4 X 8	57
-	2	2	2	2	2	5018030-2	NUT, HEX, REG, RoHS, M4	55
-	2	2	2	2	2	5018030-1	NUT, HEX, REG, RoHS, M3	54
-	2	2	2	2	2	986965-8	NUT, LOCK, HEX, TORQUE (M4)	53
-	-	-	-	1	-	2119792-2	PAWL, EF, AIR	51
-	-	-	-	1	2	18023-9	SCR, SKT HD CAP M4 X 6.0	49
-	-	-	-	-	1	2119652-1	FEED CAM, PRE FEED	48
-	-	-	-	-	1	2119653-1	FEED CAM, POST FEED	47
-	1	1	1	1	1	2119655-5	APPLICATOR BASIC ASSEMBLY, EF	46
-	1	-	1	1	1	2161310-1	RAM, STEPPED, AMP STYLE, END FEED	44
-	1	1	1	1	1	2079383-7	SCR, BHSC, RoHS (M8 X 25)	41
-	1	-	1	1	1	2119645-1	DISC, NUMBERED FA WIRE ADJUSTMENT	40
-	1	-	1	1	1	2119957-1	APPLICATOR SHIM PACK	39
-	1	1	1	1	1	1-2119644-4	RAM WASHER, PRECISION	38
-	1	1	1	1	1	2119085-1	FA HEAD, ATLANTIC STYLE	37
-	1	-	1	1	1	2119092-1	BOLT, ADJUSTMENT	35
-	7	7	7	7	7	1-18028-2	WASHER, FLAT, REG M4	33
-	2	2	2	2	2	2168083-9	SCR, SKT HD CAP, RoHS, M4 X 20	31
-	2	2	2	2	2	1-2168083-0	SCR, SKT HD CAP, RoHS, M4 X 10	29
-	1	1	1	1	1	240639-4	STRIPPER (MACHINING)	27
-	2	2	2	2	2	1320906-1	STUD, THREADED	25
-	1	1	1	1	1	1752371-1	PLATE, STRIP GUIDE	24
-	1	1	1	1	1	240825-4	PLATE, STRIP HOLD DOWN	23
-	2	2	2	2	2	2-22281-3	SPRING, COMPRESSION	22
-	1	1	1	1	1	1752373-4	DRAG	20
-	2	2	2	2	2	1901259-4	GUIDE, LOWER STRIP	18
-	4	4	4	4	4	1-2079383-1	SCR, BHSC, RoHS (M6 X 12)	17
-	1	1	1	1	1	240644-1	PLATE, REAR SHEAR	11
-	2	2	2	2	2	240645-1	SPACER, SHEAR PLATE	10
-	1	1	1	1	1	690619-4	PLATE, RETAINING	9
-	1	1	1	1	1	1803131-1	ANVIL, SPLICE TYPE	8
-	1	1	1	1	1	2-459722-7	BLADE, SHEAR	7
-	-	-	-	-	-	-	-	4
-	-	-	-	-	-	-	-	3
-	-	-	-	-	-	-	-	2
-	1	1	1	1	1	5-459736-1	CRIMPER, WIRE	1

DIMENSIONS:		TOLERANCES UNLESS OTHERWISE SPECIFIED:		DRAWN		CHK		APV		DATE	
mm	0 PLC	±	0.5	STAKEM	02SEPT2013	ELBIN	02SEPT2013	RALLEY	02SEPT2013	NAME	
	1 PLC	±	0.13	TE Connectivity		Harrisburg, PA 17105-3608		PRODUCT SPEC		Ocean End Feed Applicator	
	3 PLC	±	0.013	Customer Accessible Production Drawing		SCALE 1:1		SHEET 1 OF 4		REV B	
	4 PLC	±	0.001	Customer Accessible Production Drawing		SCALE 1:1		SHEET 1 OF 4		REV B	
	ANGLES	±	0.0001	Customer Accessible Production Drawing		SCALE 1:1		SHEET 1 OF 4		REV B	
	FINISH			Customer Accessible Production Drawing		SCALE 1:1		SHEET 1 OF 4		REV B	

LOC		DIST		REVISONS			
A	66	P	LTN	DESCRIPTION	DATE	OWN	APVD
		-		SEE SHEET 1			

FEED TYPE MECHANICAL

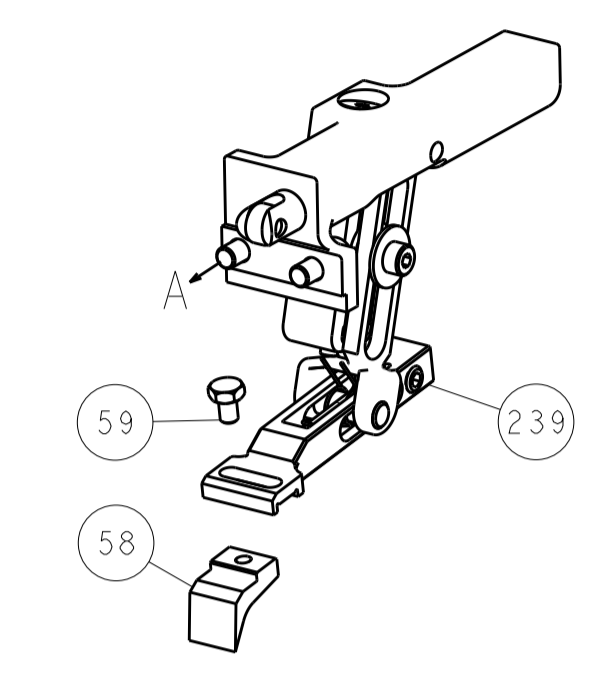

PNEUMATIC

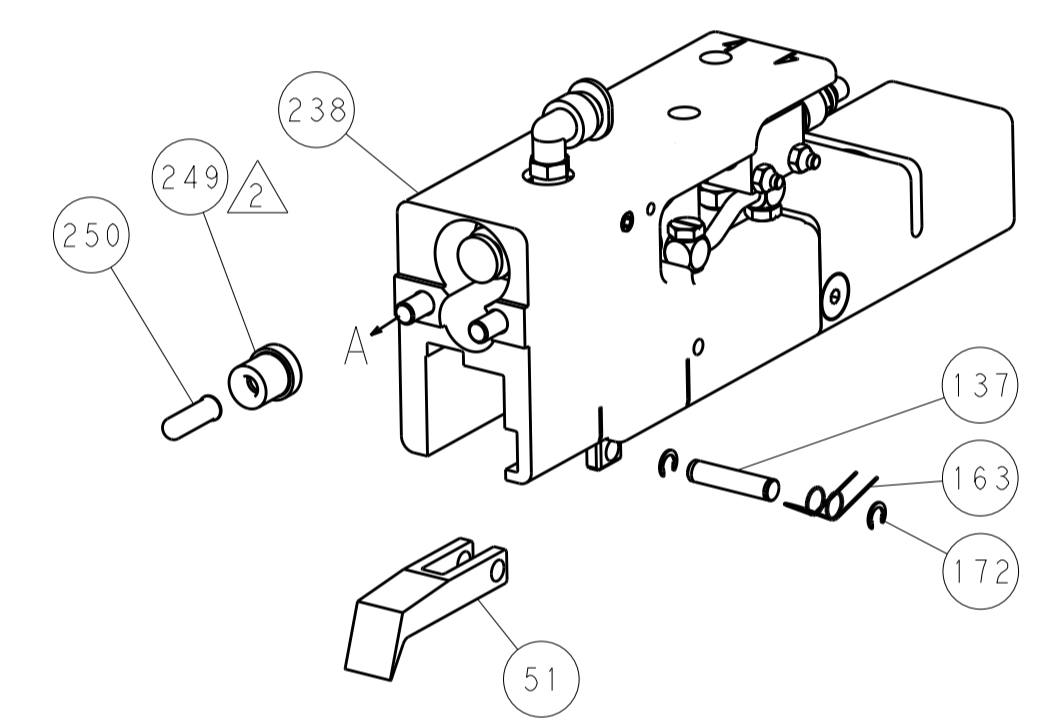

SERVO LATCH PLATE

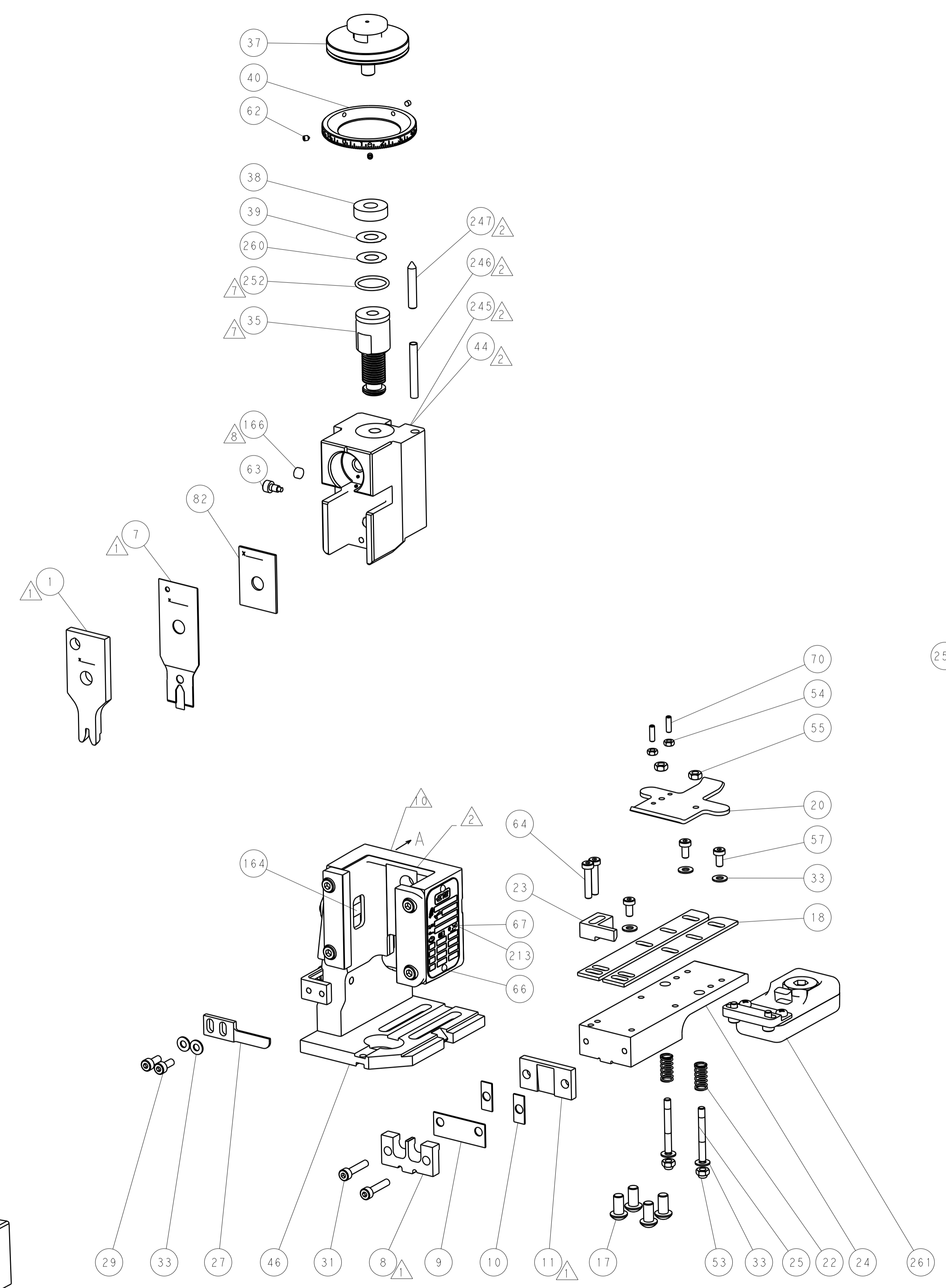
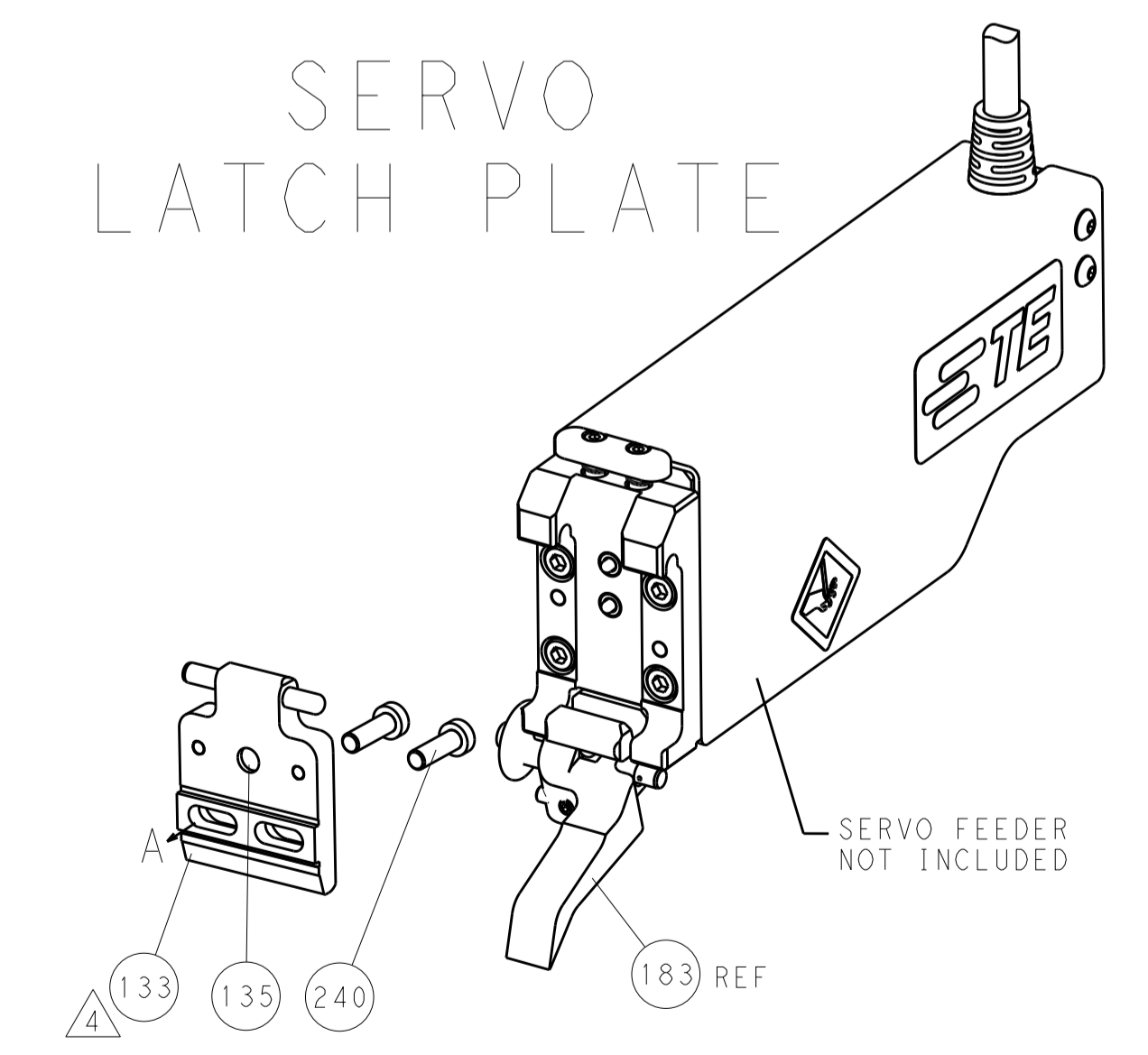

CAM POSITIONS

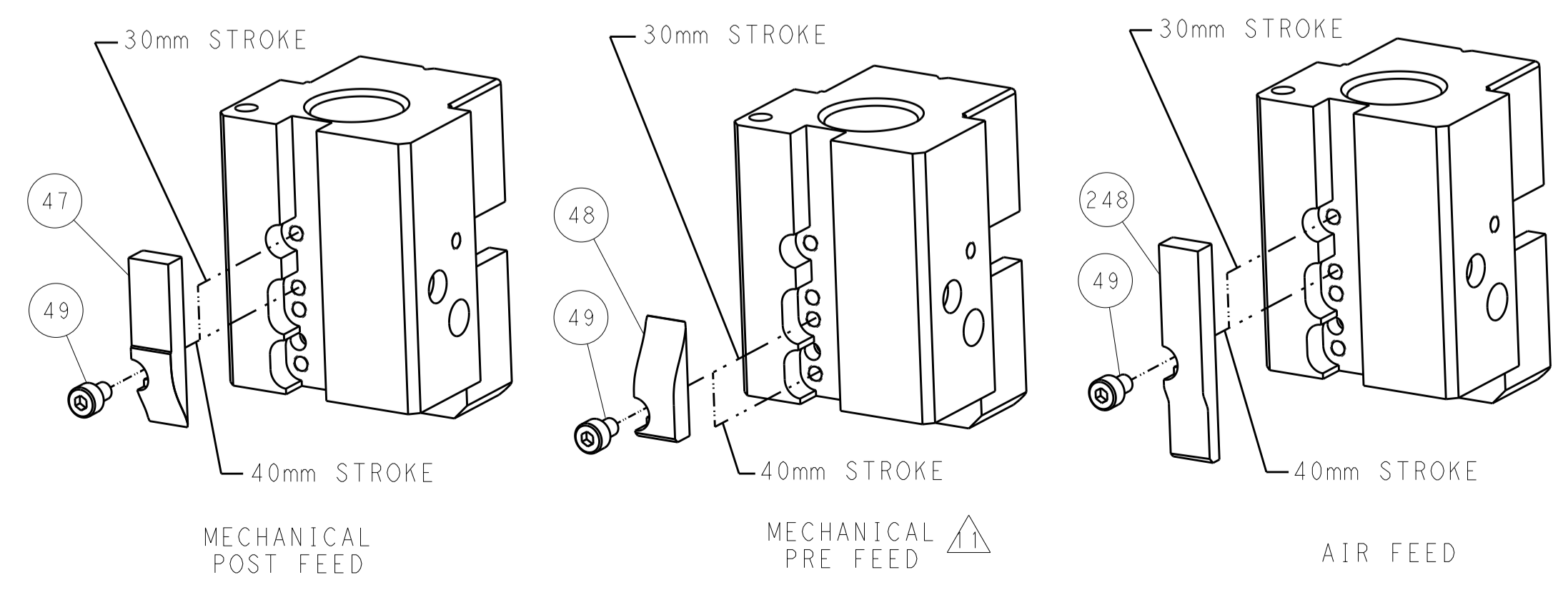

ATLANTIC VERSION
 Shown on sheets 1 of 4 & 2 of 4
 (Pacific version shown on sheets 3 of 4 & 4 of 4)

DIMENSIONS:		TOLERANCES UNLESS OTHERWISE SPECIFIED:		OWN: K. STANEM 02SEPT2013		TE Connectivity	
mm		0 PLC ±0.5		CHK: T. ELBIN 02SEPT2013		Harrisburg, PA 17105-3608	
Ø		1 PLC ±0.13		APP'D: G. RALLEY 02SEPT2013		NAME: Ocean End Feed Applicator	
FINISH:		2 PLC ±0.013		PRODUCT SPEC:		SIZE: CAGE CODE DRAWING NO. RESTRICTED TO	
MATERIAL:		3 PLC ±0.001		APPLICATION SPEC:		A11 00779 ©=2150354	
		ANGLES ±0.001		WEIGHT:		Customer Accessible Production Drawing SCALE: 1:1 SHEET 2 OF 4 REV B	

PACIFIC VERSION TERMINATOR INTERFACE ADAPTER	PART NUMBER	REVISION	DESCRIPTION	FEED TYPE	APPLICATOR STYLE CONVERSION CHART						
					CONVERT TO	PART NUMBERS REQUIRED					
	2-2150354-1	B	FINE CRIMP HEIGHT ADJUST	MECHANICAL	PNEUMATIC FEED	2119950-1	2119792-2	-	2119641-2	-	2063440-1
					SERVO LATCH PLATE	2119951-1	1901697-1	8-2150354-5	-	-	2168400-7 (QUANTITY 2)
					SMART APPLICATOR	2161326-1	-	8-2150354-4	-	-	-
	2-2150354-2	B	FINE CRIMP HEIGHT ADJUST	PNEUMATIC	MECHANICAL FEED	2119949-1	2063961-1	5-18022-5	2119653-2	-	-
					SERVO LATCH PLATE	2119951-1	1901697-1	8-2150354-5	-	-	2168400-7 (QUANTITY 2)
					SMART APPLICATOR	2161326-1	-	8-2150354-4	-	-	-
	2-2150354-5	B	FINE CRIMP HEIGHT ADJUST	SERVO LATCH PLATE	MECHANICAL FEED	2119949-1	2063961-1	5-18022-5	2119653-2	-	-
					PNEUMATIC FEED	2119950-1	2119792-2	-	2119641-2	-	2063440-1
	2-2150354-7	B	FINE CRIMP HEIGHT ADJUST	NONE	-	-	-	-	-	-	-
	7-2150354-7	A	CRIMP TOOLING KIT	-	-	-	-	-	-	-	-

APPLICATOR DATA		
CRIMP	SIZE	TYPE
WIRE	2.03mm [.080]	F
INSUL	-	-
APPLICATOR INSTRUCTIONS 408-10390		

TERMINAL DATA: GMG TERMINAL		TE CRIMP SPECIFICATION	
TERMINAL NAME: TERMINAL			
WIRE STRIP LENGTH		INSULATION DIAMETER RANGE	
6.96-7.96mm [.274-.313 IN]			
TERMINAL APPLICATION SPECIFICATION	NONE		
TERMINALS APPLIED			
TE TERMINAL	GMG TERMINAL	TE TERMINAL	GMG TERMINAL
2113361-1	33000.51.001	2113361-3	33000.04.001
2113361-2	33000.51.081		

WIRE SIZE	CRIMP HEIGHT mm [INCH]	CRIMP HEIGHT REFERENCE SETTING
1.50mm2	1.40 +/- 0.05 [.055 +/- .002]	7.4
1.00mm2	1.24 +/- 0.05 [.049 +/- .002]	9.5
0.75mm2	1.14 +/- 0.05 [.045 +/- .002]	10.7
0.50mm2	1.04 +/- 0.05 [.041 +/- .002]	11.8

- RECOMMENDED SPARE PARTS
- GREASE BEARING SURFACES LIGHTLY
- 3. LUBRICATE DAILY PER THE APPLICATOR INSTRUCTION SHEET SUPPLIED WITH THE APPLICATOR.
- APPLICATOR SPECIFIC DATA TO BE ENTERED INTO BLANK MEMORY CHIP AT ASSEMBLY. SEE BELOW FOR PART NUMBER:
 MECHANICAL FEED WITH "SMART APPLICATOR" CONVERSION: 8-2150354-4
 PNEUMATIC FEED WITH "SMART APPLICATOR" CONVERSION: 8-2150354-4
 SERVO FEED WITH "FINE CRIMP HEIGHT ADJUST": 8-2150354-5
- 5. ADJUSTMENT OF THE STRIPPER MAY BE REQUIRED WHEN MOVING THE APPLICATOR BETWEEN BENCH AND LEADMAKER APPLICATIONS.
- APPLY PART NUMBER 1-23419-5 LOCTITE TO THREADS OF ITEM 62.
- GREASE THREADS, GROOVE AND O-RING ON ITEMS 139 & 153.
- MAGNET, ITEM 166 MUST BE ORIENTED CORRECTLY IN ORDER TO PROPERLY ACTUATE THE COUNTER.
- CRIMP HEIGHT REFERENCE SETTING WAS THE SETTING USED WHEN THE APPLICATOR WAS QUALIFIED AT THE FACTORY. ADJUSTMENT MAY BE NECESSARY WHEN RUNNING APPLICATOR IN THE FIELD.
- SPARE FEED CAM STORAGE LOCATION REFER TO INSTRUCTION SHEET FOR ADDITIONAL INFORMATION.
- THE RECOMMENDED SET-UP FOR END FEED APPLICATORS IS POST-FEED WITH ITEM 2119653-1. THE APPLICATOR CAN BE CONFIGURED FOR PRE-FEED WITH ITEM 2119652-1 BUT MAY ENCOUNTER PROBLEMS WITH SOME APPLICATIONS. FEED ISSUES OR TERMINAL JAMMING MAY OCCUR IN THE PRE-FEED CONFIGURATION.
- TERMINAL LUBRICATOR IS RECOMMENDED.

***WARNING**
 ON INSTALLATION, SET WIRE DISC, ITEM 40 TO LARGEST WIRE SIZE SETTING. USE OF SETTINGS BELOW MINIMUM REQUIRED CRIMP HEIGHT SETTING WILL CAUSE DAMAGE TO CRIMP TOOLING.

PACIFIC VERSION
 Shown on sheets 3 of 4 & 4 of 4
 (Atlantic version shown on sheets 1 of 4 & 2 of 4)

SET UP GAUGE	LOC	DIST	REVISIONS			
2119599-2	A	66	REV	DATE	BY	APPV
			-	SEE SHEET 1	-	-

-	1	1	1	1	2119955-2	ASSY, LUBRICATOR, END FEED	261
-	1	1	1	1	2119782-1	FINE ADJUST HEAD ASM, PACIFIC STYLE	251
-	-	-	1	-	2119640-1	PUSH ROD, AIR FEED	250
-	-	-	1	-	2079988-1	BUSHING, LCH5-12, MISUMI	249
-	1	1	1	1	1-22279-3	SPRING, COMPRESSION	246
-	-	2	-	-	2168400-7	SHCS, LOW HEAD, RoHS, M5 X 10	240
-	-	-	-	1	2119580-1	MECHANICAL FEED ASSEMBLY	239
-	-	-	1	-	2063440-1	AIR FEED MODULE	238
-	-	1	-	-	2119740-2	TAG, IDENTIFICATION	213
-	4	4	4	4	2079383-9	SCR, BHSC, RoHS (M6 X 20)	186
-	-	REF	-	-	1901697-1	FEED FINGER ASSEMBLY, EF	183
-	-	-	2	-	21045-3	RING, RETAIN, EXTERN, 3/16 CRESCENT	172
-	1	1	1	1	994969-1	MAGNET, RARE EARTH HIGH ENERGY	166
-	REF	REF	REF	REF	994970-2	COUNTER, MAGNETIC	164
-	-	-	1	-	240638-1	SPRING, FEED FINGER	163
-	1	1	1	1	8-21084-1	O-RING, .801 ID, .070 DIA. MAT.	153
-	-	-	1	-	2119641-2	FEED CAM, AIR FEED	152
-	1	1	1	1	2119798-2	DETENT PIN	145
-	-	-	-	1	2119653-2	FEED CAM, POST FEED	142
-	1	1	1	1	2119655-6	APPLICATOR BASIC ASSEMBLY, EF	141
-	1	1	1	1	2161313-1	RAM, STEPPED, ASIAN STYLE, END FEED	140
-	1	1	1	1	2119092-2	BOLT, ADJUSTMENT	139
-	-	-	1	-	3-23627-7	PIN, RETAIN, GRVD, 3/16 X .854	137
-	-	REF	-	-	SEE NOTE 4	MEMORY CHIP, PROGRAMMED	135
-	-	1	-	-	1633743-1	SERVO FEED LATCH ASM	133
-	1	1	1	1	1-455888-1	SPACER, CRIMPER	82
-	1	1	1	1	2119956-2	DOCUMENTATION PACKAGE	71
-	2	2	2	2	2-18032-2	SCR, SET, FLT POINT M3 X 10.0	70
-	1	-	1	1	2119740-1	TAG, IDENTIFICATION	67
-	2	2	2	2	2168078-1	SCREW, DRIVE, RH, RoHS, 2 x .188	66
-	2	2	2	2	2168400-5	SHCS, LOW HEAD, RoHS, M4 X 20	64
-	1	1	1	1	2119793-1	LIMITER, ADJUSTMENT BOLT	63
-	3	3	3	3	992763-5	SCR, SET, SOC, CONE POINT, M3 X 4.0	62
-	-	-	-	1	5-18022-5	SCR, HEX HD CAP, M4 X 6.0	59
-	-	-	-	1	2063961-1	FEED FINGER	58
-	3	3	3	3	2168400-4	SHCS, LOW HEAD, RoHS, M4 X 8	57
-	2	2	2	2	5018030-2	NUT, HEX, REG, RoHS, M4	55
-	2	2	2	2	5018030-1	NUT, HEX, REG, RoHS, M3	54
-	2	2	2	2	986965-8	NUT, LOCK, HEX, TORQUE (M4)	53
-	-	-	1	-	2119792-2	PAWL, EF, AIR	51
-	-	-	1	2	18023-9	SCR, SKT HD CAP M4 X 6.0	49
-	-	-	-	1	2119652-1	FEED CAM, PRE FEED	48
-	1	1	1	1	2079383-7	SCR, BHSC, RoHS (M8 X 25)	41
-	1	1	1	1	2119645-1	DISC, NUMBERED FA WIRE ADJUSTMENT	40
-	1	1	1	1	2119957-1	APPLICATOR SHIM PACK	39
-	1	1	1	1	1-2119644-4	RAM WASHER, PRECISION	38
-	7	7	7	7	1-18028-2	WASHER, FLAT, REG M4	33
-	2	2	2	2	2168083-9	SCR, SKT HD CAP, RoHS, M4 X 20	31
-	2	2	2	2	1-2168083-0	SCR, SKT HD CAP, RoHS, M4 X 10	29
-	1	1	1	1	240639-4	STRIPPER (MACHINING)	27
-	2	2	2	2	1320906-1	STUD, THREADED	25
-	1	1	1	1	1752371-1	PLATE, STRIP GUIDE	24
-	1	1	1	1	240825-4	PLATE, STRIP HOLD DOWN	23
-	2	2	2	2	2-22281-3	SPRING, COMPRESSION	22
-	1	1	1	1	1752373-4	DRAG	20
-	2	2	2	2	1901259-4	GUIDE, LOWER STRIP	18
-	1	1	1	1	240644-1	PLATE, REAR SHEAR	11
-	2	2	2	2	240645-1	SPACER, SHEAR PLATE	10
-	1	1	1	1	690619-4	PLATE, RETAINING	9
-	1	1	1	1	1803131-1	ANVIL, SPLICE TYPE	8
-	1	1	1	1	2-459722-7	BLADE, SHEAR	7
-	-	-	-	-	-	-	4
-	-	-	-	-	-	-	3
-	-	-	-	-	-	-	2
-	1	1	1	1	5-459736-1	CRIMPER, WIRE	1

DIMENSIONS:		TOLERANCES UNLESS OTHERWISE SPECIFIED:		MATERIAL:		FINISH:		WEIGHT:		SCALE:	
mm	0 PLC ±.5	1 PLC ±0.5	2 PLC ±0.13	3 PLC ±0.013	4 PLC ±0.001	ANGLES	±.0001				
APPLICATOR SPEC		APPLICATOR SPEC		MATERIAL		FINISH		WEIGHT		SCALE	
Customer Accessible Production Drawing		Customer Accessible Production Drawing		Customer Accessible Production Drawing		Customer Accessible Production Drawing		Customer Accessible Production Drawing		Customer Accessible Production Drawing	

LOC	DIST	REV	DATE	BY	APPV
A	66				

FEED TYPE MECHANICAL

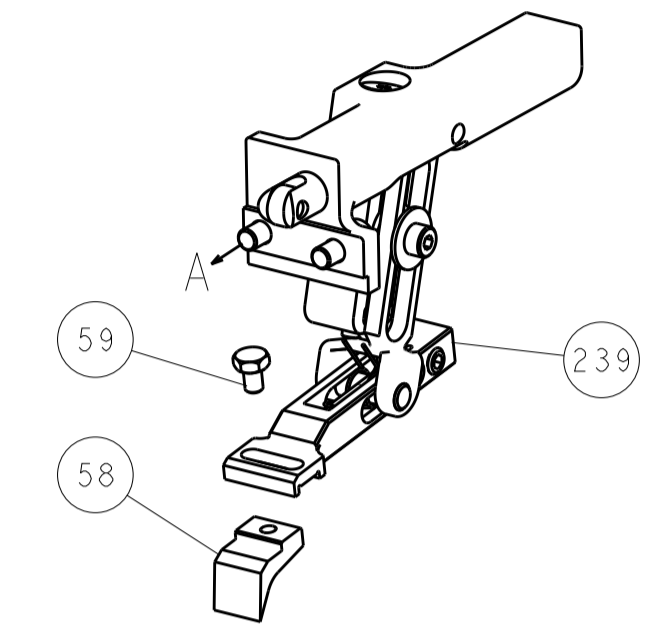

PNEUMATIC

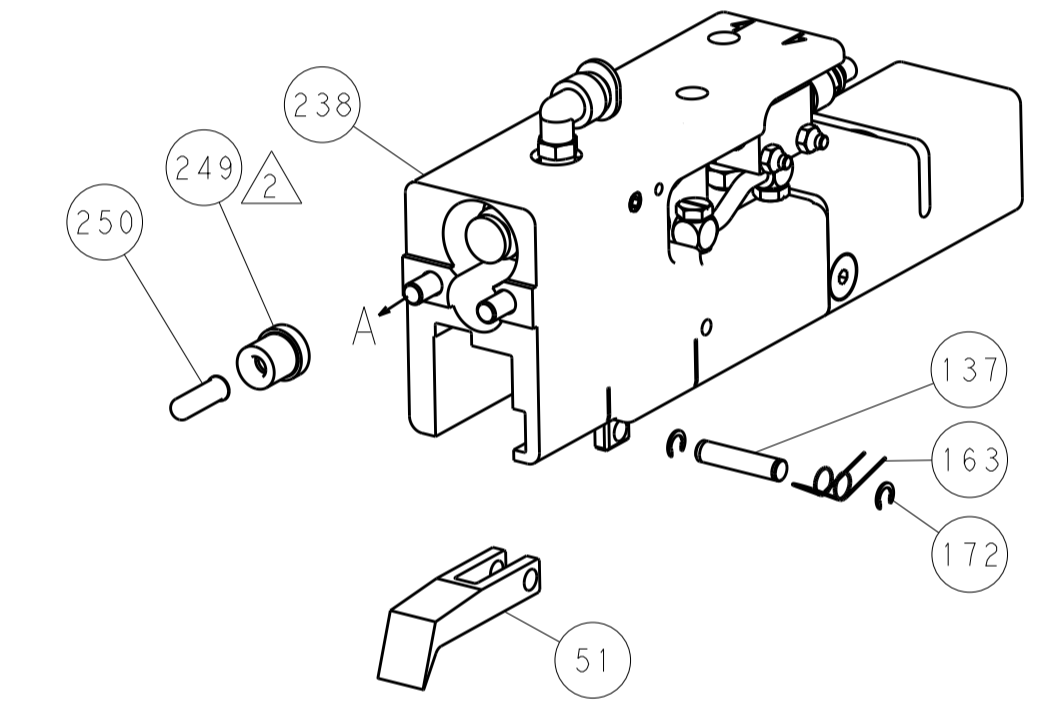

SERVO LATCH PLATE

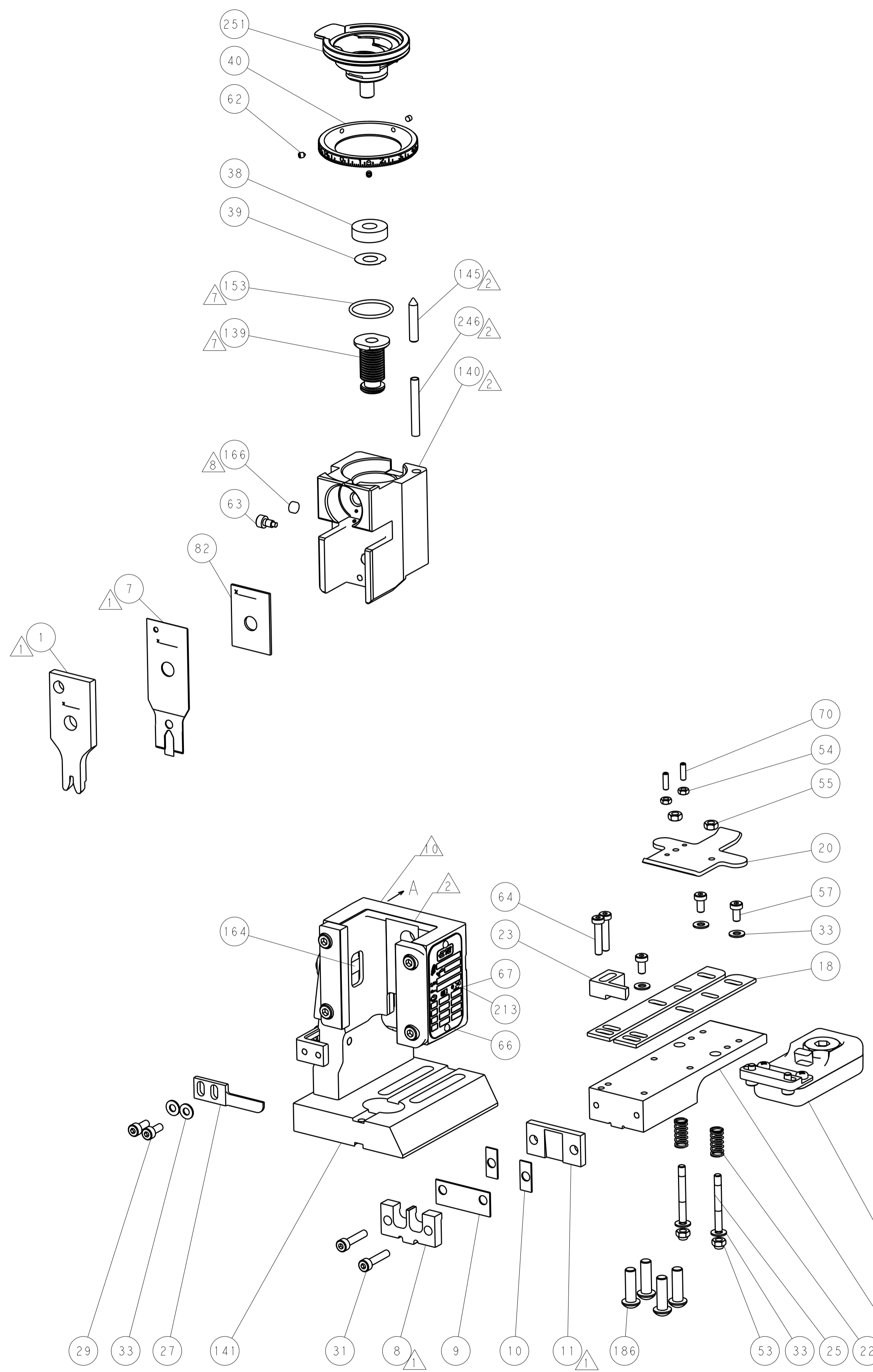
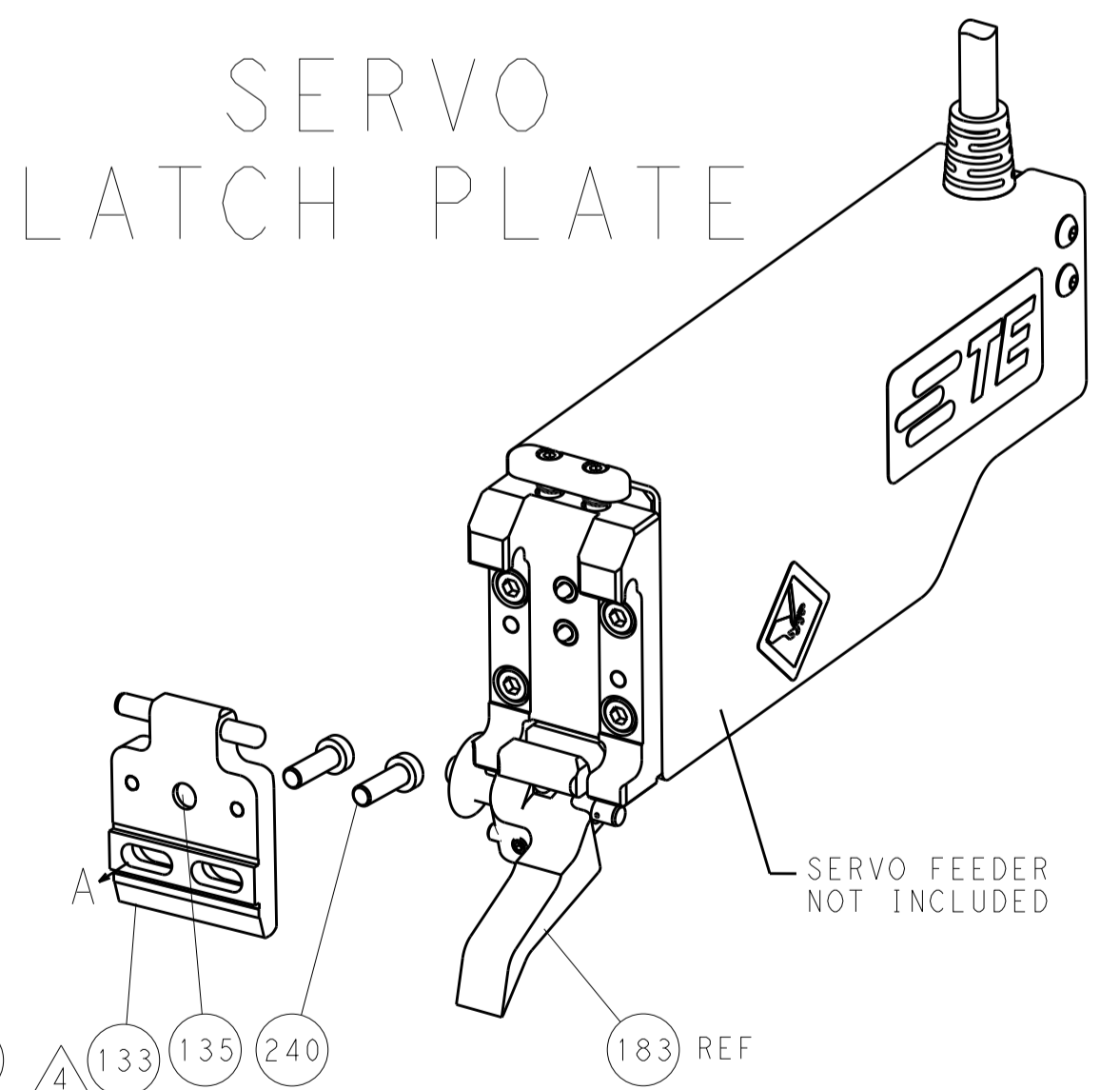

CAM POSITIONS

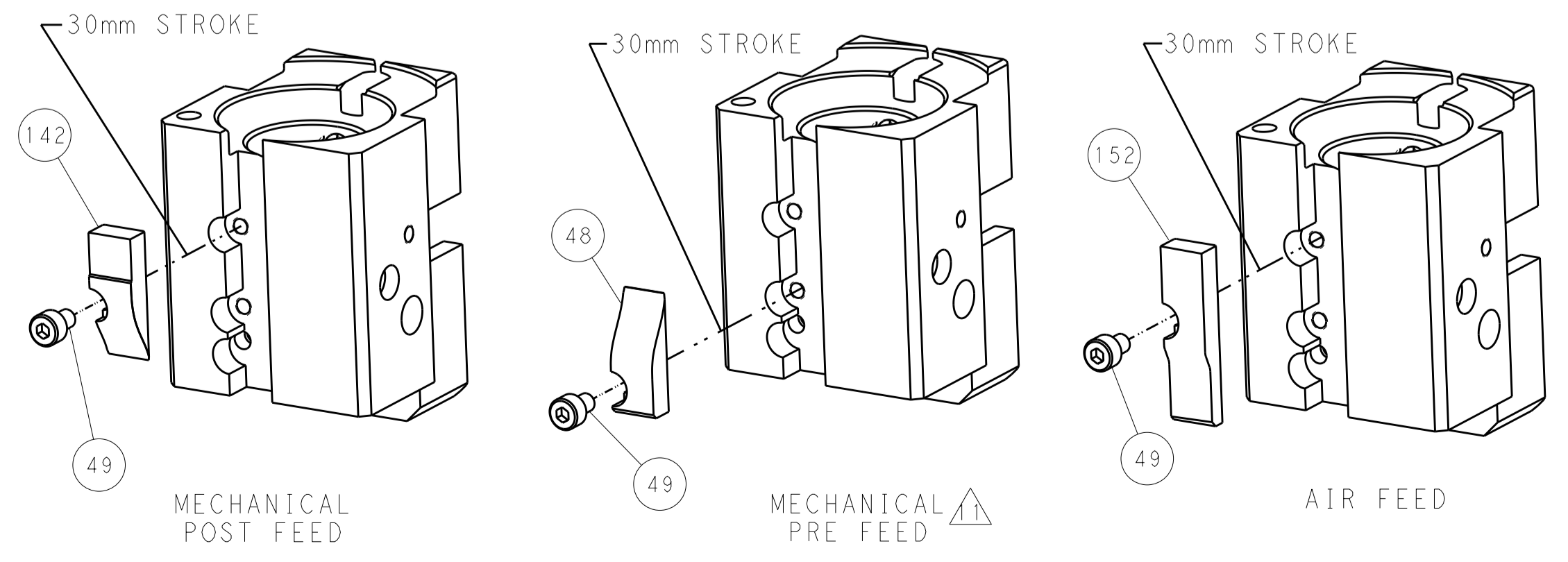

PACIFIC VERSION
 Shown on sheets 3 of 4 & 4 of 4
 (Atlantic version shown on sheets 1 of 4 & 2 of 4)

DIMENSIONS: mm 		TOLERANCES UNLESS OTHERWISE SPECIFIED: 0 PLC ±.5 1 PLC ±0.5 2 PLC ±0.13 3 PLC ±0.013 4 PLC ±0.001 ANGLES ±.1		DWN: STANEM 02SEPT2013 CHK: T. ELBIN 02SEPT2013 APVD: G. RALLEY 02SEPT2013 PRODUCT SPEC APPLICATION SPEC WEIGHT CUSTOMER ACCESSIBLE PRODUCTION DRAWING		NAME: Ocean End Feed Applicator SIZE: A1 CAGE CODE: 00779 DRAWING NO: 2150354 SCALE: 1:1 SHEET: 4 of 4 REV: B		STE TE Connectivity Harrisburg, PA 17105-3608	
-----------------------	--	--	--	--	--	---	--	--	--