

| | | | | | | |
|------|------|------|------|------|-------------------|-----|
| 30.3 | 30.5 | 32.6 | 29.5 | 33.7 | 51296-6033 | 60 |
| 27.3 | 27.5 | 29.6 | 26.5 | 30.7 | 51296-5433 | 54 |
| 25.3 | 25.5 | 27.6 | 24.5 | 28.7 | 51296-5033 | 50 |
| 22.8 | 23.0 | 25.1 | 22.0 | 26.2 | 51296-4533 | 45 |
| 20.3 | 20.5 | 22.6 | 19.5 | 23.7 | 51296-4033 | 40 |
| 17.3 | 17.5 | 19.6 | 16.5 | 20.7 | 51296-3433 | 34 |
| 9.3 | 9.5 | 11.6 | 8.5 | 12.7 | 51296-1833 | 18 |
| 7.3 | 7.5 | 9.6 | 6.5 | 10.7 | 51296-1433 | 14 |
| 6.3 | 6.5 | 8.6 | 5.5 | 9.7 | 51296-1233 | 12 |
| 4.3 | 4.5 | 6.6 | 3.5 | 7.7 | 51296-0833 | 8 |
| E | D | C | B | A | EMBOSSED TAPE | 極数 |
| | | | | | ORDER No. オオーダー番号 | Ckt |

CONNECTOR SERIES NO. : 51296-**22

| | | | | | | | |
|------------------------------------------------------------------------------------------------------------------|---------------------------------------|-------------------------------------------------------------------------------------------------------------------------------|----------------------------|------------------------------|----------------------------------------------|------------------------|------------------------|
| REVISED EC NO: J2014-0096 DRW: AISHII 2013/07/18 CHK: KTAKAHASHI 2013/07/18 APPR: YNOGAWA 2013/08/19 | GENERAL TOLERANCES (UNLESS SPECIFIED) | | DIMENSION STYLE MM ONLY | | SCALE --- | DESIGN UNITS METRIC | THIRD ANGLE PROJECTION |
| | 10 UNDER | ± --- | DRAWN BY AISHII | DATE 2012/09/19 | TITLE 0.5MM FPC CONN F/F E/O HOUSING ASSY | | |
| | 10 OVER 30 UNDER | ± --- | CHECKED BY KTAKAHASHI | DATE 2012/09/19 | | | |
| | 30 OVER | ± --- | APPROVED BY KMORIKAWA | DATE 2013/03/15 | | | |
| ANGULAR | ± --- ° | MATERIAL NO. SEE CHART | | DOCUMENT NO. SD-51296-017 | SHEET NO. 1 OF 2 | | |
| DRAFT WHERE APPLICABLE MUST REMAIN WITHIN DIMENSIONS | | THIS DRAWING CONTAINS INFORMATION THAT IS PROPRIETARY TO MOLEX INCORPORATED AND SHOULD NOT BE USED WITHOUT WRITTEN PERMISSION | | | | | |

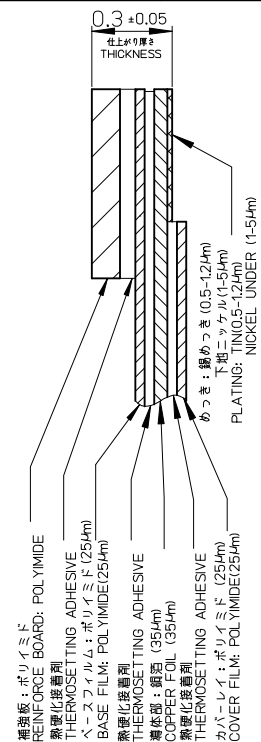
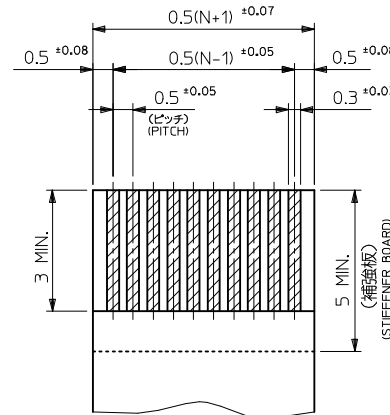
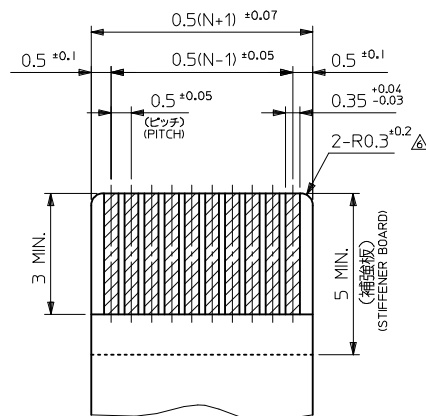
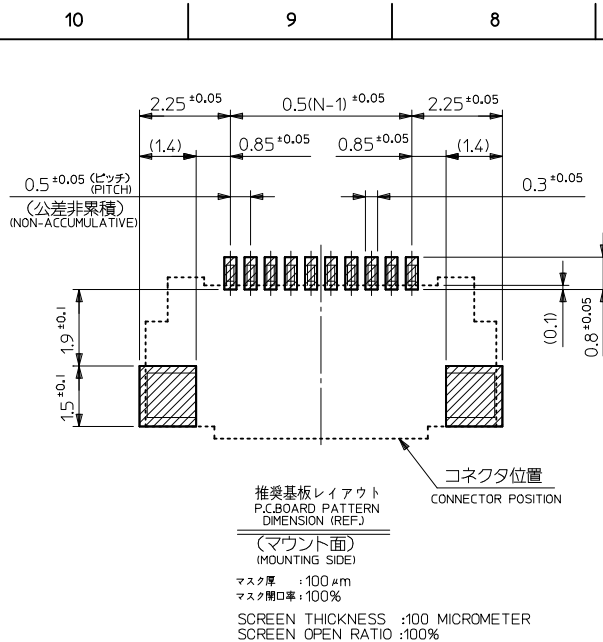

注記 NOTES

1. 使用材料 MATERIAL

- ハウジング : 液晶ポリマー(LCP), ベージュ, ガラス充填, UL94V-0
HOUSING LIQUID CRYSTAL POLYMER, BEIGE, GLASS FILLED, UL94V-0
- アクチュエータ : ポリアミド(PPS), 黒, ガラス充填, UL94V-0
ACTUATOR POLYAMIDE, BLACK, GLASS FILLED, UL94V-0
- ターミナル : リン青銅 (t=0.18)
TERMINAL PHOSPOR BRONZE
- 金具 : リン青銅 (t=0.15)
FITTING NAIL PHOSPOR BRONZE

2. メッキ仕様 PLATING

- ターミナル TERMINAL
 - 鍍銀ビスマスマッキ (1.0 μm以上)
 - TIN SILVER BISMUTH PLATING (1.0 MICROMETER MINIMUM)
 - 下地: ニッケルめっき(1.0 μm以上)
 - UNDER PLATING: NICKEL PLATING (1.0 MICROMETER MINIMUM)
- 金具 FITTING NAIL
 - 鍍メッキ (1.0 μm以上)
 - TIN PLATING (1.0 MICROMETER MINIMUM)
 - 下地: ニッケルめっき(1.0 μm以上)
 - UNDER PLATING: NICKEL PLATING (1.0 MICROMETER MINIMUM)

3. エンボステップ梱包時は、アクチュエータが閉じた状態とする。
IN THE PACKAGE, ACTUATOR SHOULD BE CLOSED.

△ 偶数極に適用。
APPLY FOR EVEN CIRCUIT.

△ パターンはくり止め用金具
FITTING NAIL FOR PREVENTION OF PEELING OF PCB PATTERN.

△ R0.3は、FPC導体部にかからないこと。
R0.3 MUST NOT BE OVERLAPPED TO PATTERN OF FPC.

△ 極数によりハウジング形状が異なるので注意のこと。
THE HOUSING SHAPE IS DIFFERENT ACCORDING TO THE CIRCUIT.

8. テール及び金具の平坦度は、0.1ミリメートル以下とする。
TAIL AND FITTING NAIL COPLANARITY TO BE 0.1 MILLIMETERS.

9. ELV及びRoHS適合品
ELV AND RoHS COMPLIANT

FPCについて:

- 抜き方向は、導体側から補強板側を推奨致します。
- 補強フィルム材質は、ポリイミドを推奨致します。
- 接着剤は熱硬化接着剤を推奨します。
- 尚、接着剤の接点部への付着は導通不良の原因になりますので、
- 染み出しが無い様お願い致します。

ABOUT FPC:

- RECOMMENDED PUNCHER DIRECTION:
FROM CONDUCTOR SIDE TO STIFFENER SIDE
- RECOMMENDED MATERIAL : STIFFENER FILM POLYIMIDE
- BONDING AGENT : THERMOSETTING AGENT
- PLEASE PUT APPROPRIATE AMOUNT OF ADHESIVE ON ADHEREND
- BECAUSE THERE IS A POSSIBILITY THAT THE EXTRA ADHESIVE
- CAUSES THE DEFECT IN ELECTRICAL CONTINUITY.

FFC/FPCについて:

- 打抜き方向は導体側から補強板側を推奨致します。
- 導体部については軟銅箔35 μmまたは50 μmを推奨致します。

ABOUT FFC/FPC:

- RECOMMENDED PUNCHER DIRECTION:
FROM CONDUCTOR SIDE TO STIFFENER FILM SIDE.
- RECOMMENDED CONDUCTOR SPECIFICATION:
THICKNESS OF SOFT COPPER FOIL: 35MICROMETER OR 50 MICROMETER

FPC構成推奨仕様
STRUCTURE OF FPC

| | | | | | | | | | |
|----------------------------------------------------------------------------------------------------------------------------|-------------|---------------------------------------|------------------------------------------------------|----------------------------|-------------------------------------------------------------------------------------------------------------------------------|----------------------------------------------|-----------------------------|------------------------------|---------------------|
| SEE SHEET 1 OF 2 EC NO: J2014-0096 DRAWN: AISHI 2013/07/18 CHKD: TAKAHASHI 2013/07/18 APPR: YNOGAWA 2013/08/19 | DESCRIPTION | GENERAL TOLERANCES (UNLESS SPECIFIED) | | DIMENSION STYLE MM ONLY | | SCALE --- | DESIGN UNITS METRIC | THIRD ANGLE PROJECTION | |
| | | 10 UNDER | ± --- | DRAWN BY AISHI | DATE 2012/09/19 | TITLE 0.5MM FPC CONN F/F E/O HOUSING ASSY | | | |
| | | 10 OVER 30 UNDER | ± --- | CHECKED BY TAKAHASHI | DATE 2012/09/19 | | | | |
| | | 30 OVER | ± --- | APPROVED BY KMORIKAWA | DATE 2013/03/15 | | | | |
| B | REV | ANGULAR ± --- ° | DRAFT WHERE APPLICABLE MUST REMAIN WITHIN DIMENSIONS | SIZE A3 | THIS DRAWING CONTAINS INFORMATION THAT IS PROPRIETARY TO MOLEX INCORPORATED AND SHOULD NOT BE USED WITHOUT WRITTEN PERMISSION | | MATERIAL NO. SEE SHEET 1 | DOCUMENT NO. SD-51296-017 | SHEET NO. 2 OF 2 |

NOTES

- 製品詳細寸法については図面 SD-51296-017 を参照下さい。
RE DETAILED DIMENSION, SEE SD-51296-017.
- 梱包数量：3000個/リール
NUMBER OF CONNECTORS : 3000PCS/REEL
- リードテープ長さ LEAD TAPE LENGTH

引き出し方向
PULL OUT DIRECTION

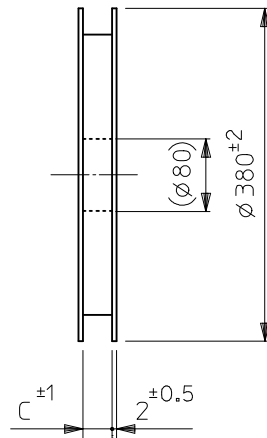
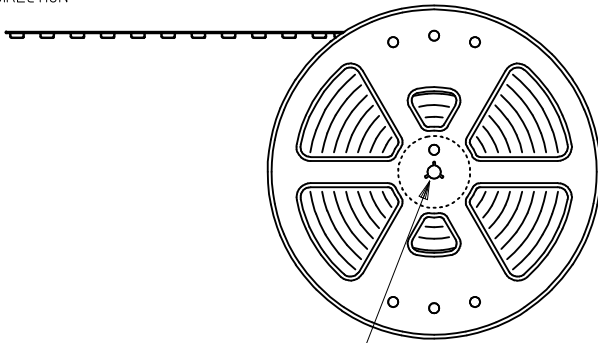

引き出し方向
PULL OUT DIRECTION

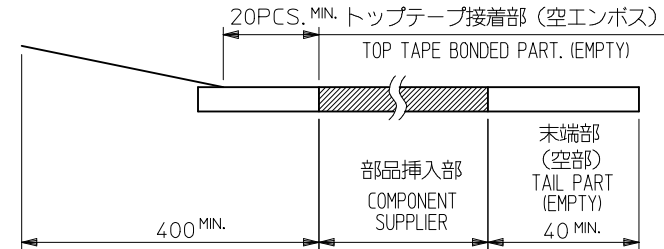

- カバーテープの剥離強度については、IEC60286-3に準拠
COVER TAPE PEEL FORCE IS DEFINED BY IEC 60286-3.
- 材料
MATERIAL
キャリアテープ：ポリスチレン (PS)
CARRIER TAPE: POLYSTYRENE (PS)
トップテープ：ポリスチレン (PS)
TOP TAPE : POLYSTYRENE (PS)
リール：ポリスチレン (PS)
REEL: POLYSTYRENE
- ELV及びRoHS適合品
ELV AND RoHS COMPLIANT

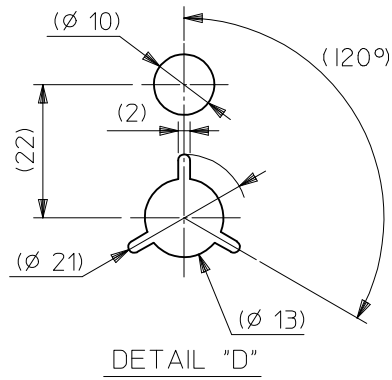

| | | | | | | | |
|---------------------------------------------------------------------------------------------------------------------|---------------------------------------|------------|-------------------------------------------------------------------------------------------------------------------------------|--------------------|-----------------------------------------------------------------------------|------------------------|------------------------|
| RELEASED EC NO: J2013-1002 DRW: AISHII 2012/09/19 CHK: KTAKAHASHI 2012/09/19 APPR: KMORIKAWA 2013/03/15 | GENERAL TOLERANCES (UNLESS SPECIFIED) | | DIMENSION STYLE MM ONLY | | SCALE --- | DESIGN UNITS METRIC | THIRD ANGLE PROJECTION |
| | 10 UNDER | ± --- | DRAWN BY AISHII | DATE 2012/09/19 | TITLE EMBOSS TAPE PACKAGED FOR 0.5MM FPC CONN F/F E/O HOUSING ASSY | | |
| | 10 OVER 30 UNDER | ± --- | CHECKED BY KTAKAHASHI | DATE 2012/09/19 | | | |
| | 30 OVER | ± --- | APPROVED BY KMORIKAWA | DATE 2013/03/15 | | | |
| | ANGULAR | ± --- ° | MATERIAL NO. SEE CHART | | DOCUMENT NO. SD-51296-018 | SHEET NO. 1 OF 3 | |
| DRAFT WHERE APPLICABLE MUST REMAIN WITHIN DIMENSIONS | | SIZE A3 | THIS DRAWING CONTAINS INFORMATION THAT IS PROPRIETARY TO MOLEX INCORPORATED AND SHOULD NOT BE USED WITHOUT WRITTEN PERMISSION | | | | |

引き出し方向
PULL OUT DIRECTION

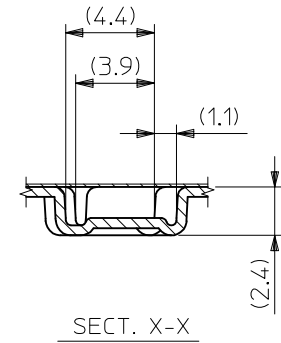
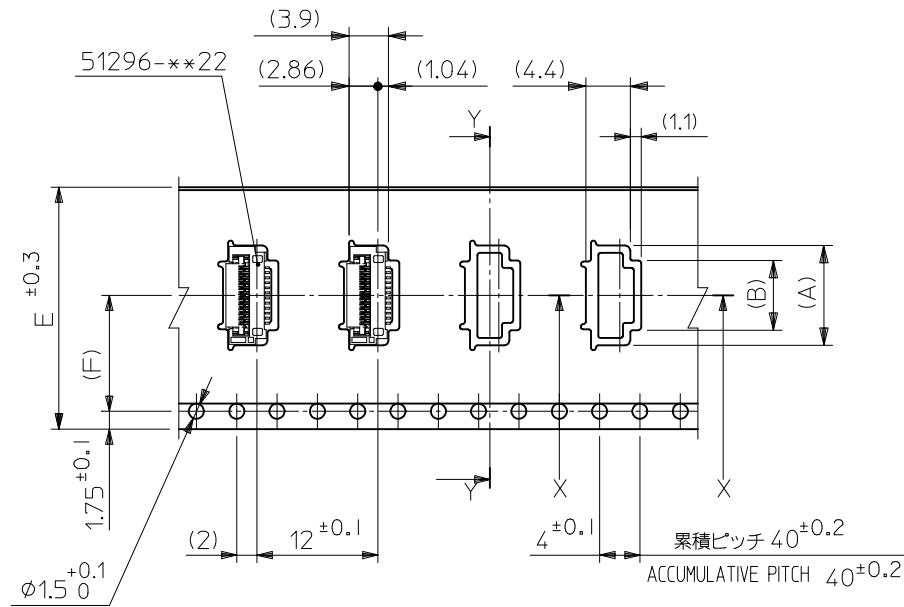
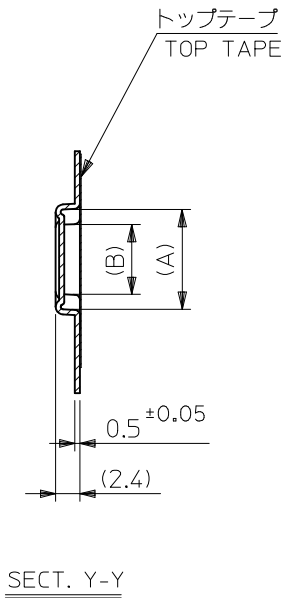

| | | | | | | | |
|------|----|------|------|------|------|---------------------|-----------|
| 11.5 | 24 | 25.4 | 29.4 | 9.89 | 12.9 | 51296-1833 | 18 |
| | | | | 7.89 | 10.9 | 51296-1433 | 14 |
| | | | | 6.89 | 9.9 | 51296-1233 | 12 |
| 7.5 | 16 | 17.4 | 21.4 | 4.89 | 7.9 | 51296-0833 | 8 |
| (F) | E | D | C | (B) | (A) | 製品番号 MATERIAL No | 極数 Ckt |

| | | | | | | | | | |
|-------------------------------------------------------------------------------------------------------------------------------|-----------------------|------------------------------------------------------|-------|----------------------------|--------------------|-----------------------------------------------------------------------------|------------------------|------------------------|--|
| SEE SHEET 1 OF 3 EC NO: J2013-1002 DRW: AISHII 2012/09/19 CHKD: KTAKAHASHI 2012/09/19 APPR: KMORIKAWA 2013/03/15 | DESCRIPTION REV: 0 | GENERAL TOLERANCES (UNLESS SPECIFIED) | | DIMENSION STYLE MM ONLY | | SCALE --- | DESIGN UNITS METRIC | THIRD ANGLE PROJECTION | |
| | | 10 UNDER | ± --- | DRAWN BY AISHII | DATE 2012/09/19 | TITLE EMBOSS TAPE PACKAGED FOR 0.5MM FPC CONN F/F E/O HOUSING ASSY | | | |
| | | 10 OVER 30 UNDER | ± --- | CHECKED BY KTAKAHASHI | DATE 2012/09/19 | | | | |
| | | 30 OVER | ± --- | APPROVED BY KMORIKAWA | DATE 2013/03/15 | | | | |
| ANGULAR ± --- ° | | DRAFT WHERE APPLICABLE MUST REMAIN WITHIN DIMENSIONS | | MATERIAL NO. SEE CHART | | DOCUMENT NO. SD-51296-018 | | SHEET NO. 2 OF 3 | |
| THIS DRAWING CONTAINS INFORMATION THAT IS PROPRIETARY TO MOLEX INCORPORATED AND SHOULD NOT BE USED WITHOUT WRITTEN PERMISSION | | | | | | | | | |

10 9 8 7 6 5 4 3 2 1

引き出し方向
PULL OUT DIRECTION

トップテープ
TOP TAPE

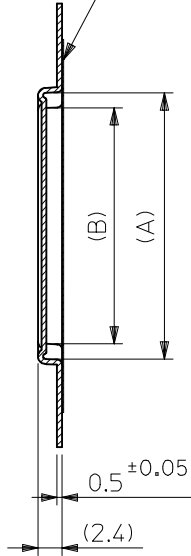

SECT. Y-Y

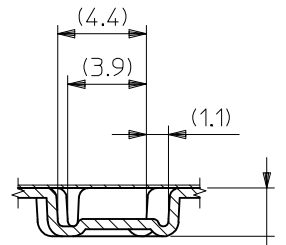
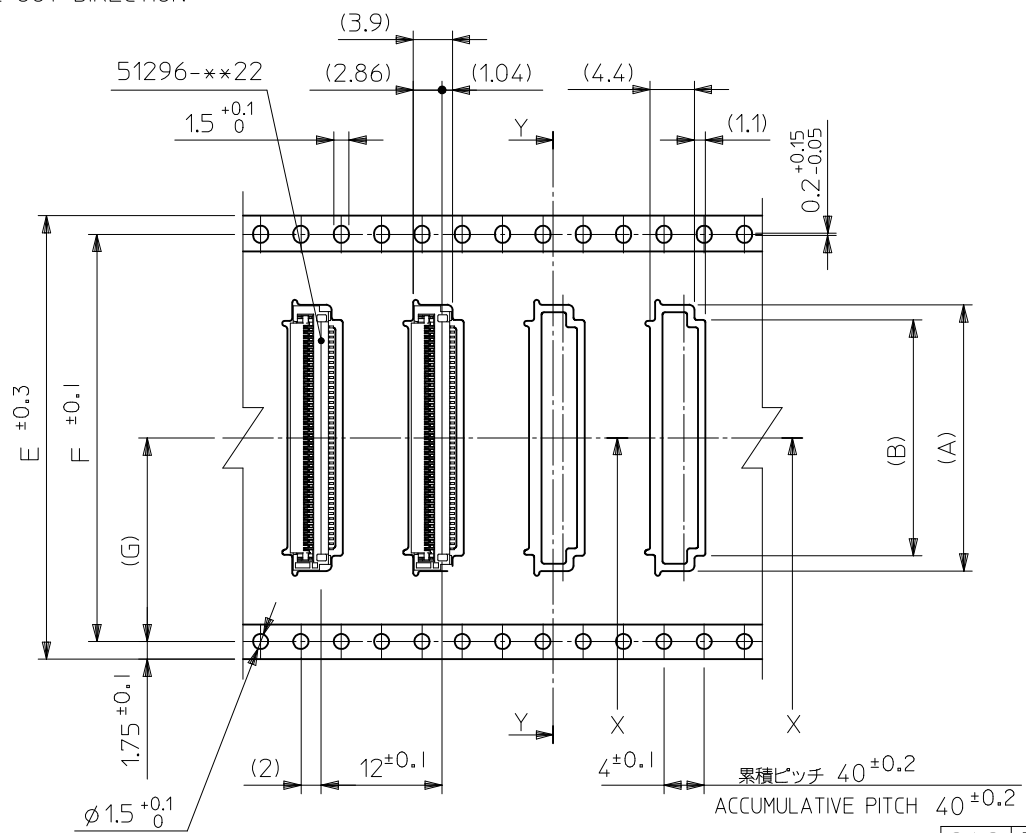

SECT. X-X

| | | | | | | | | |
|------|------|----|------|------|-------|------|---------------------|-----------|
| 26.2 | 52.4 | 56 | 57.4 | 61.4 | 30.89 | 33.9 | 51296-6033 | 60 |
| | | | | | 27.89 | 30.9 | 51296-5433 | 54 |
| 20.2 | 40.4 | 44 | 45.4 | 49.4 | 25.89 | 28.9 | 51296-5033 | 50 |
| | | | | | 23.39 | 26.4 | 51296-4533 | 45 |
| | | | | | 20.89 | 23.9 | 51296-4033 | 40 |
| 14.2 | 28.4 | 32 | 33.4 | 37.4 | 17.89 | 20.9 | 51296-3433 | 34 |
| (G) | F | E | D | C | (B) | (A) | 製品番号 MATERIAL No | 極数 Ckt |

| | | | | | | | | | |
|------------------------------------------------------------------------------------------------------------------------------|---------------------------------------|-------|----------------------------|--------------|--------------------|------------------------|-----------------------------------------------------------------------------|--|--|
| SEE SHEET 1 OF 3 EC NO: J2013-1002 DRWN: AISHII 2012/09/19 CHKD: TAKAHASHI 2012/09/19 APPR: KMORIKAWA 2013/03/15 | GENERAL TOLERANCES (UNLESS SPECIFIED) | | DIMENSION STYLE MM ONLY | | SCALE --- | DESIGN UNITS METRIC | THIRD ANGLE PROJECTION | | |
| | 10 UNDER | ± --- | DRAWN BY AISHII | | DATE 2012/09/19 | | TITLE EMBOSS TAPE PACKAGED FOR 0.5MM FPC CONN F/F E/O HOUSING ASSY | | |
| | 10 OVER 30 UNDER | ± --- | CHECKED BY TAKAHASHI | | DATE 2012/09/19 | | | | |
| | 30 OVER | ± --- | APPROVED BY KMORIKAWA | | DATE 2013/03/15 | | | | |
| | ANGULAR ± --- ° | | | MATERIAL NO. | | DOCUMENT NO. | | | |
| DRAFT WHERE APPLICABLE MUST REMAIN WITHIN DIMENSIONS | | | SEE CHART | | SD-51296-018 | | 3 OF 3 | | |

9 8 7 6 5 4 3 2

THIS DRAWING CONTAINS INFORMATION THAT IS PROPRIETARY TO MOLEX INCORPORATED AND SHOULD NOT BE USED WITHOUT WRITTEN PERMISSION