

THIS DRAWING IS UNPUBLISHED. RELEASED FOR PUBLICATION  
 © COPYRIGHT - By - ALL RIGHTS RESERVED.

LOC	DIST	REVISIONS			
P	LTR	DESCRIPTION	DATE	DWN	APVD
AF	50	AS3	REVISED PER ECR-18-013918	27SEP2018	BDA DH

- 1 CONTINUOUS STRIP ON REELS.
- 2 MATING TAB THK IS  $.012 \pm .001$ .
- 3 WIRE SIZE IS #22-#18 AWG.
- 4 INSULATION RANGE IS  $.060-.100$  DIA
- 5 REELED ON PLASTIC REELS.
- 6 PLATING THICKNESS:  $.00023$  INCH MIN
- 7 SAME AS -1 BUT WITH PAPER INTERLEAVE.

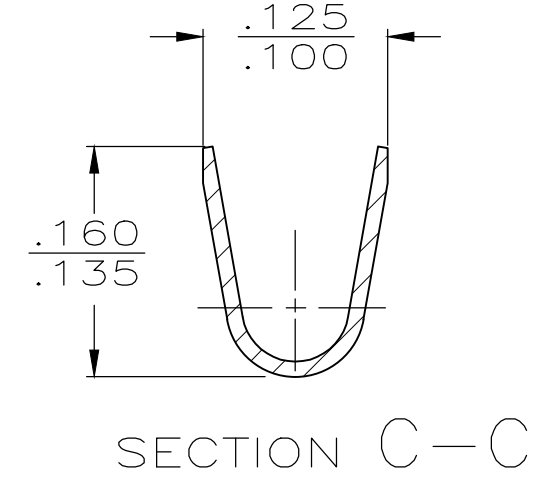
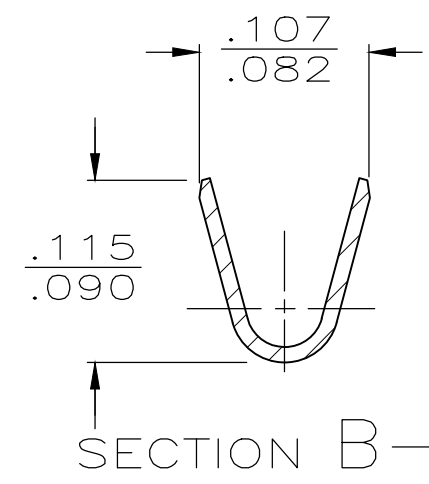
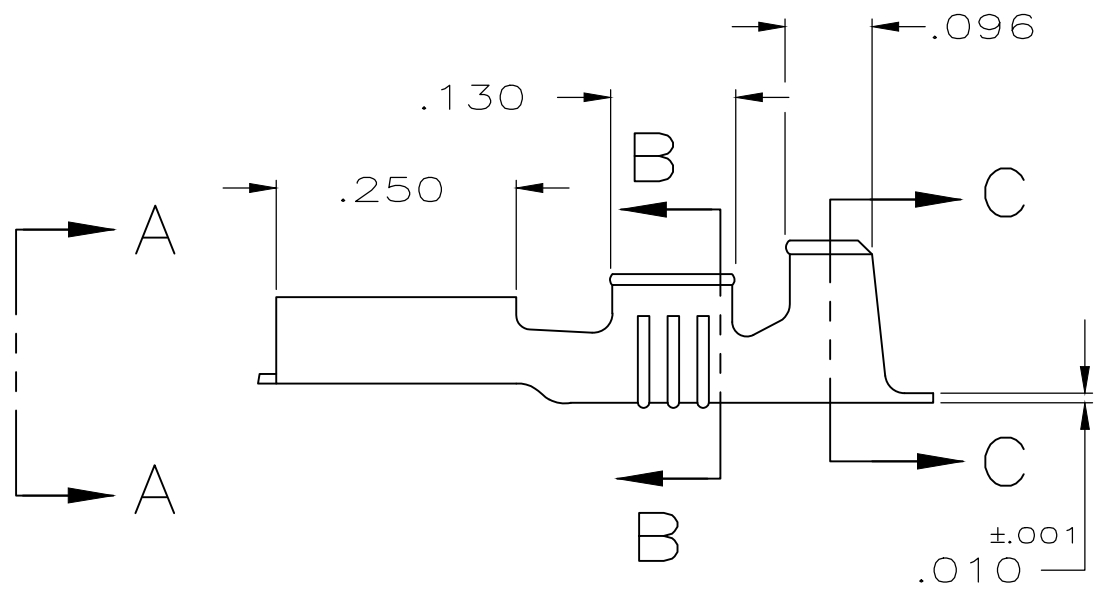
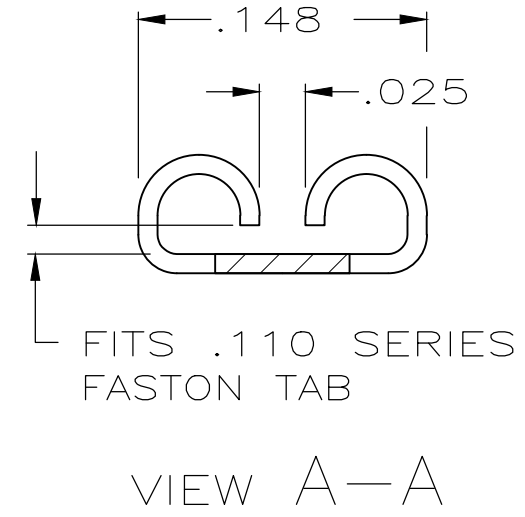
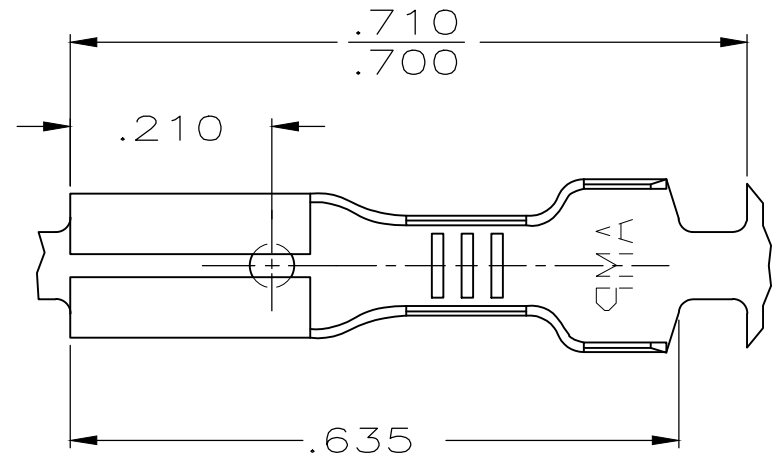

TIN PLATING	BRASS	60415-6	7
NICKEL PLATING	BRASS	60415-5	6
-	BRASS	60415-4	
TIN PLATING	BRASS	60415-2	5
TIN PLATING	BRASS	60415-1	
FINISH	MATERIAL	PART NUMBER	

THIS DRAWING IS A CONTROLLED DOCUMENT.		DWN	JR RUTH	6/23/87	TE Connectivity RECEPTACLE, FASTON,™ .110 SERIES								
DIMENSIONS: INCHES		CHK	G YETTER	6/23/87									
TOLERANCES UNLESS OTHERWISE SPECIFIED:		APVD	C MEYERS	6/23/87									
0 PLC ± - 1 PLC ± - 2 PLC ± - 3 PLC ± .015 4 PLC ± - ANGLES ± -		PRODUCT SPEC		NAME									
MATERIAL	BRASS	FINISH	PRE-TIN	WEIGHT	0.244	SIZE	A3	CAGE CODE	00779	DRAWING NO	C-60415	RESTRICTED TO	-
CUSTOMER DRAWING						SCALE	5:1	SHEET	1 OF 1	REV	AS3		