

PART NUMBER	REVISION	DESCRIPTION	FEED TYPE
2150425-1	F	FINE CRIMP HEIGHT ADJUST	MECHANICAL
2150425-2	F	FINE CRIMP HEIGHT ADJUST	PNEUMATIC
7-2150425-1	F	MECHANICAL AND CRIMP TOOLING KIT	MECHANICAL
7-2150425-2	F	PNEUMATIC AND CRIMP TOOLING KIT	PNEUMATIC
7-2150425-7	A	CRIMP TOOLING KIT	-

ATLANTIC VERSION TERMINATOR INTERFACE ADAPTER



APPLICATOR DATA		
CRIMP	SIZE	TYPE
WIRE	3.56 mm [.140]	F
INSUL	7.11 mm [.280]	F

APPLICATOR INSTRUCTIONS 408-35043

TERMINAL DATA: TE TERMINAL		TE CRIMP SPECIFICATION	
TERMINAL NAME: RECEPTACLE, FASTON, LOW-INSERTION, .250 SERIES			
WIRE STRIP LENGTH		INSULATION DIAMETER RANGE	
.237-.267 IN [6.02-6.78 mm]		∅.210-.265 IN [5.33-6.73 mm]	
TERMINAL APPLICATION SPECIFICATION	(A)114-2036		
	(B)114-35000		
TERMINALS APPLIED			
TE TERMINAL (A) 63757-1	TE TERMINAL (A) 63757-2	TE TERMINAL (B) 63800-1	TE TERMINAL

WIRE SIZE	CRIMP HEIGHT mm [INCH]	CRIMP HEIGHT REFERENCE SETTING
12 AWG	2.13+/-0.050 [.084+/- .002]	6.3
14 AWG	1.83+/-0.050 [.072+/- .002]	9.7
(2) 18	1.75+/-0.050 [.069+/- .002]	10.3
16 AWG	1.68+/-0.05 [.066+/- .002]	11.2

- 1 RECOMMENDED SPARE PARTS
- 2 REFER TO SUPPLIED INSTRUCTION SHEET FOR CLEANING, LUBRICATION AND STORAGE OF APPLICATOR.
- 3 APPLY PART NUMBER 2-23419-6 LOCTITE TO THREADS OF ITEM 242. APPLY PART NUMBER 1-23419-5 LOCTITE TO THREADS OF ITEM 180.
- 4 CRIMP HEIGHT REFERENCE SETTING WAS THE SETTING USED WHEN THE APPLICATOR WAS QUALIFIED AT THE FACTORY. ADJUSTMENT MAY BE NECESSARY WHEN RUNNING APPLICATOR IN THE FIELD.
- 5 TERMINAL LUBRICANT IS RECOMMENDED.
- 6. UNLESS SPECIFIED OTHERWISE TORQUE VALUES SHALL BE USED PER DOCUMENT, 101-35000.
- 7 ITEM #261 FOR (2)18 AWG WIRE SIZES. ITEM #3 FOR ALL OTHER WIRE SIZES.

***WARNING**
ON INSTALLATION, SET WIRE DISC TO CRIMP HEIGHT REFERENCE SETTING FOR LARGEST WIRE SIZE. CRIMP HEIGHT REFERENCE SETTINGS GREATER THAN THE VALUE SHOWN MAY CAUSE DAMAGE TO THE CRIMP TOOLING. REFER TO THE INSTRUCTION SHEET FOR PROPER SETUP AND ADJUSTMENTS.

LOC	DIST	REVISIONS					
A	66	P	LTN	DESCRIPTION	DATE	DWN	APVD
		C		ECR-19-004657	24MAR2019	TB	CT
		D		ECR-19-011670	24JUL2019	JAH	GB
		E		ECR-21-120178	08NOV2021	JWC	TE
		F		ECR-23-165965	09FEB2023	LG	JAH

1	2	2	1	1	3-1803016-1	CRIMPER, INSULATION F	261	
-	1	-	1	-	2119641-1	FEED CAM, AIR FEED	248	
-	1	1	1	1	2119082-9	CAM, SNAIL, INSULATION ADJUSTMENT	244	
-	1	1	1	1	2079764-1	WASHER, WAVE SPRING, CREST-TO-CREST	243	
3	-	1	1	1	2119083-1	RETAINER, INSULATION DIAL	242	
-	-	1	-	1	2119580-1	MECHANICAL FEED ASSEMBLY	239	
-	1	-	1	-	2844940-3	AIR FEED MODULE	238	
-	1	1	1	1	1-18028-0	WASHER, FLAT, REG M8	192	
3	-	1	1	1	1-1976055-3	STANDOFF, HOLD-DOWN	180	
-	1	1	1	1	6-993111-6	PIN, SLOTTED SPRING 3.0 X 14.0	177	
-	1	1	1	1	8-22280-7	SPRING, COMPRESSION	176	
-	1	1	1	1	1752353-2	GUIDE PIN, HOLDDOWN	175	
-	1	1	1	1	1901680-2	GUIDE PIN, HOLDDOWN	174	
-	REF	REF	REF	REF	994970-2	COUNTER, MAGNETIC	164	
5	-	1	1	1	2119955-2	ASSY, LUBRICATOR, END FEED	84	
-	1	1	1	1	455888-6	SPACER, CRIMPER	82	
-	1	1	1	1	1803607-4	DOCUMENTATION PACKAGE	71	
-	2	2	2	2	2-18032-2	SCR, SET, FLT PNT, M3 X 10.0	70	
-	1	1	1	1	2119740-1	TAG, IDENTIFICATION	67	
-	2	2	2	2	2168078-1	SCREW, DRIVE, RH, RoHS, 2 x .188	66	
-	1	1	1	1	1901681-1	HOLDDOWN, TERMINAL	65	
-	2	2	2	2	2168400-5	SHCS, LOW HEAD, RoHS, M4 X 20	64	
-	1	1	1	1	2168083-2	SCR, SKT HD CAP, RoHS, M4 X 8.0	60	
-	-	2	-	2	5-18022-5	SCR, HEX HD CAP, M4 X 6.0	59	
-	-	1	-	1	2063961-1	FEED FINGER	58	
-	3	3	3	3	2168400-4	SHCS, LOW HEAD, RoHS, M4 X 8	57	
-	2	2	2	2	1-2168083-0	SCR, SKT HD CAP, RoHS, M4 X 10	56	
-	2	2	2	2	5018030-1	NUT, HEX, REG, RoHS, M3	54	
-	2	2	2	2	986965-8	NUT, LOCK, HEX, TORQUE (M4)	53	
-	1	1	1	1	1-5018030-0	NUT, HEX, REG, RoHS, M3.5	52	
-	1	-	1	-	2063961-1	FEED FINGER	51	
-	1	2	1	2	18023-9	SCR, SKT HD CAP M4 X 6.0	49	
-	-	1	-	1	2119652-1	FEED CAM, PRE FEED	48	
-	-	1	-	1	2119653-1	FEED CAM, POST FEED	47	
-	1	1	1	1	2119655-5	APPLICATOR BASIC ASSEMBLY, EF	46	
-	1	1	1	1	1803517-1	RAM ASSEMBLY, EF ATLANTIC	44	
-	1	1	1	1	1803602-1	SCR, BHSC, RoHS (M8 X 25)	41	
-	7	7	7	7	1-18028-2	WASHER, FLAT, REG M4	33	
-	2	2	2	2	2079383-5	SCR, BHSC, RoHS (M4 X 20)	31	
-	2	2	2	2	2168083-2	SCR, SKT HD CAP, RoHS, M4 X 8.0	29	
-	1	1	1	1	240639-1	STRIPPER (MACHINING)	27	
-	2	2	2	2	1-2168083-5	SCR, SKT HD CAP, RoHS, M4 X 30	25	
-	1	1	1	1	1-1752371-6	PLATE, STRIP GUIDE	24	
-	1	1	1	1	240825-8	PLATE, STRIP HOLD DOWN	23	
-	2	2	2	2	2-22281-3	SPRING, COMPRESSION	22	
-	1	1	1	1	1803292-4	DRAG	20	
-	2	2	2	2	1901259-6	GUIDE, LOWER STRIP	18	
-	4	4	4	4	1-2079383-1	SCR, BHSC, RoHS (M6 X 12)	17	
-	1	1	1	1	240641-9	SPACER	16	
-	1	1	1	1	1752360-1	SPACER, HOLD-DOWN	13	
-	1	1	1	1	240644-9	PLATE, REAR SHEAR	11	
-	-	-	-	-	-	-	10	
-	1	1	1	1	5-690482-9	PLATE, FRONT SHEAR	9	
1	2	2	1	1	4-1803000-6	ANVIL, COMBINATION, END FEED	8	
-	1	1	1	1	1-2217206-3	BLADE, SLUG	7	
-	-	-	-	-	-	-	6	
-	1	1	1	1	240641-8	SPACER	5	
-	1	1	1	1	238011-2	BLOCK, CRIMPER SPACER	4	
7	1	2	2	1	3-1803016-4	CRIMPER, INSULATION F	3	
-	1	1	1	1	1-455888-0	SPACER, CRIMPER	2	
1	2	2	1	1	456425-8	CRIMPER, WIRE .140 F PREMIUM	1	
-	77	72	71	2	-1	PART NO	DESCRIPTION	ITEM NO

ATLANTIC VERSION
Shown on sheets 1 of 4 & 2 of 4
(Pacific version shown on sheets 3 of 4 & 4 of 4)

DIMENSIONS:		TOLERANCES UNLESS OTHERWISE SPECIFIED:		MATERIAL:		FINISH:		WEIGHT:		SCALE:		SHEET:		REV:	
mm	0 PLC	±													
	1 PLC	±													
	2 PLC	±													
	3 PLC	±													
	4 PLC	±													
	ANGLES	±													

Customer Accessible Production Drawing

LOC	DIST	REV	DESCRIPTION	DATE	OWN	APVD
A	66		SEE SHEET 1			

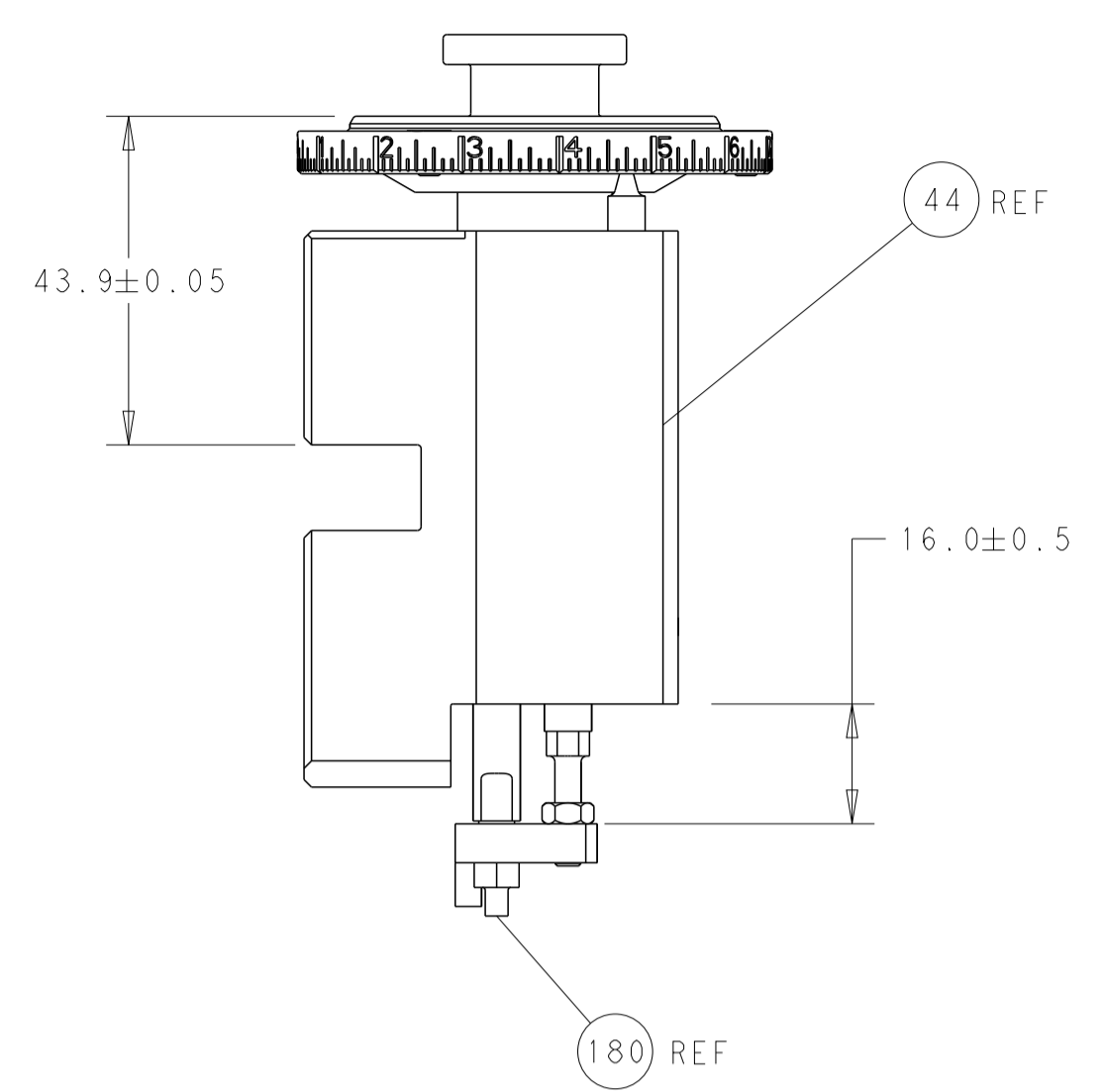

RAM AND HOLDDOWN SET-UP

FEED TYPE
MECHANICAL

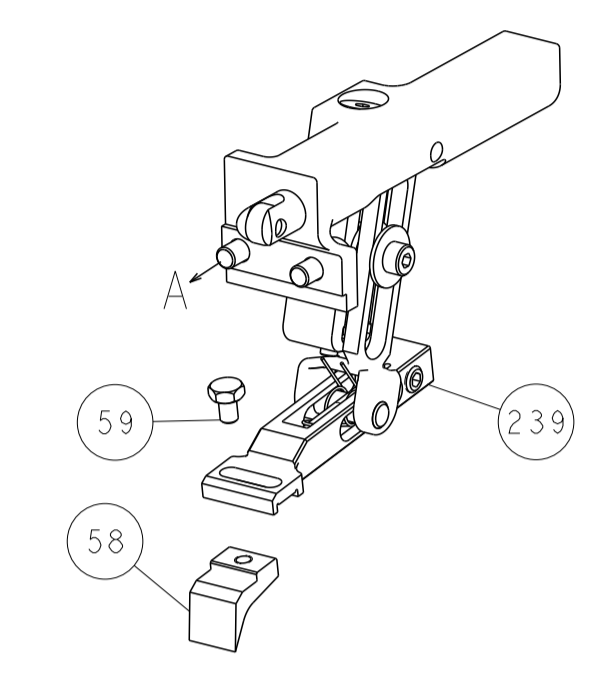

PNEUMATIC

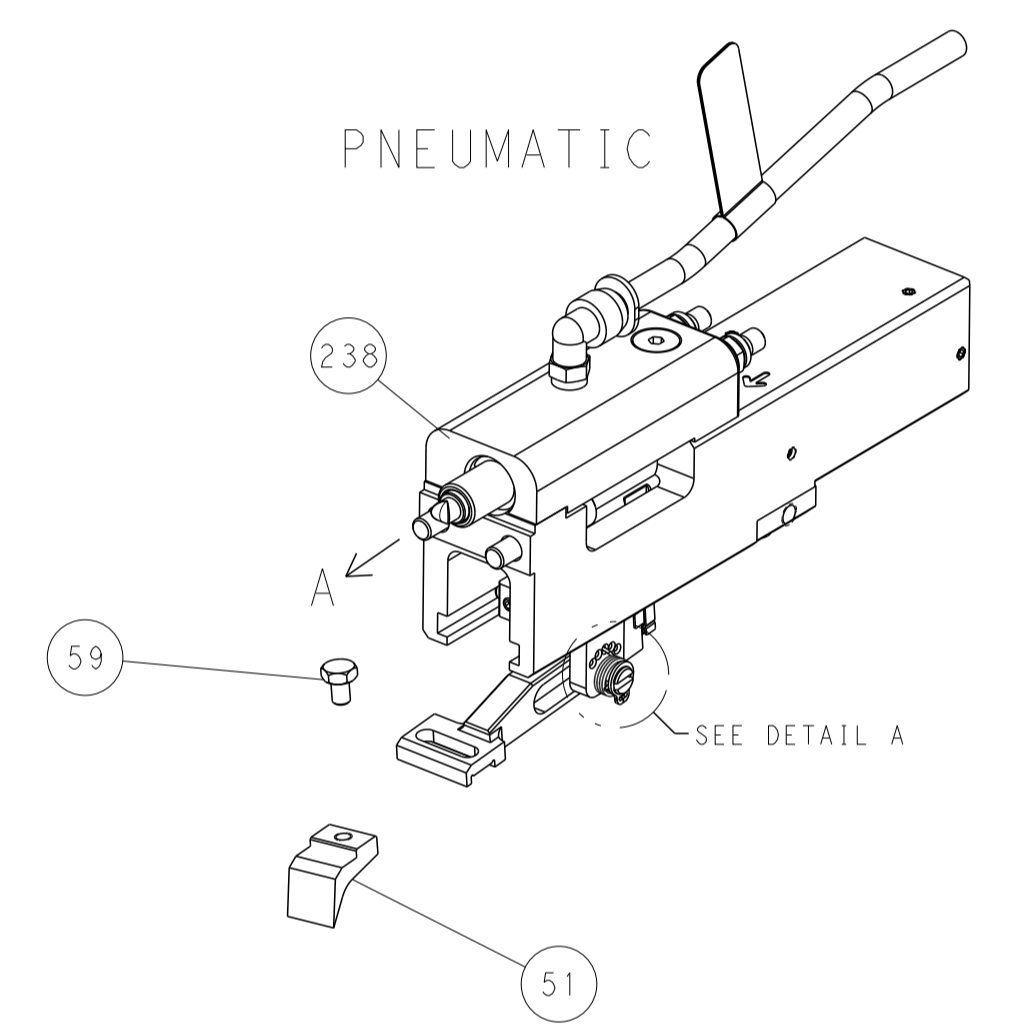

FEED SPRING
SETTING POSITION

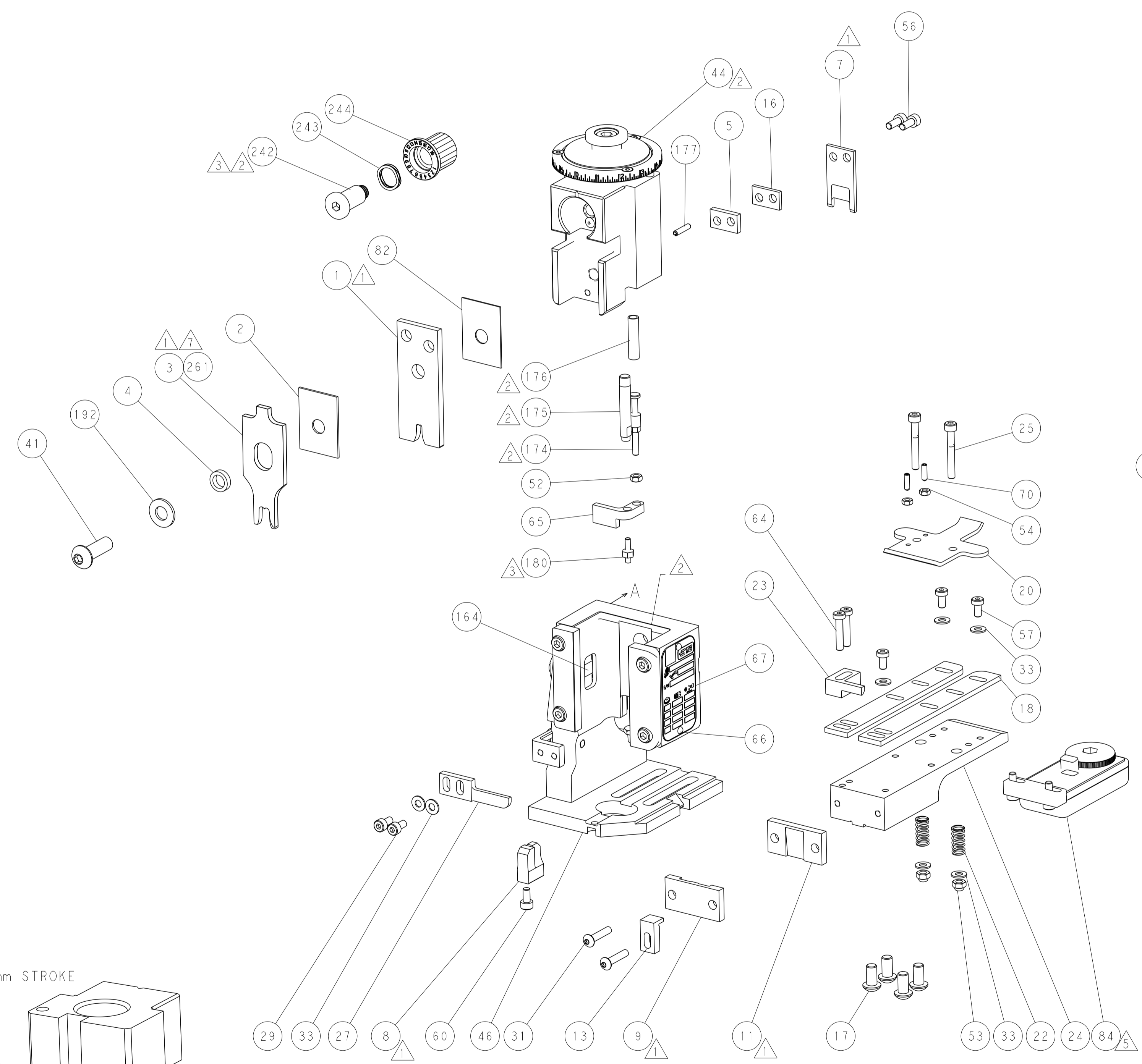
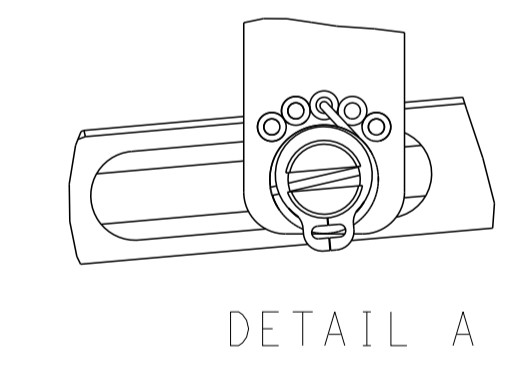

CAM POSITIONS

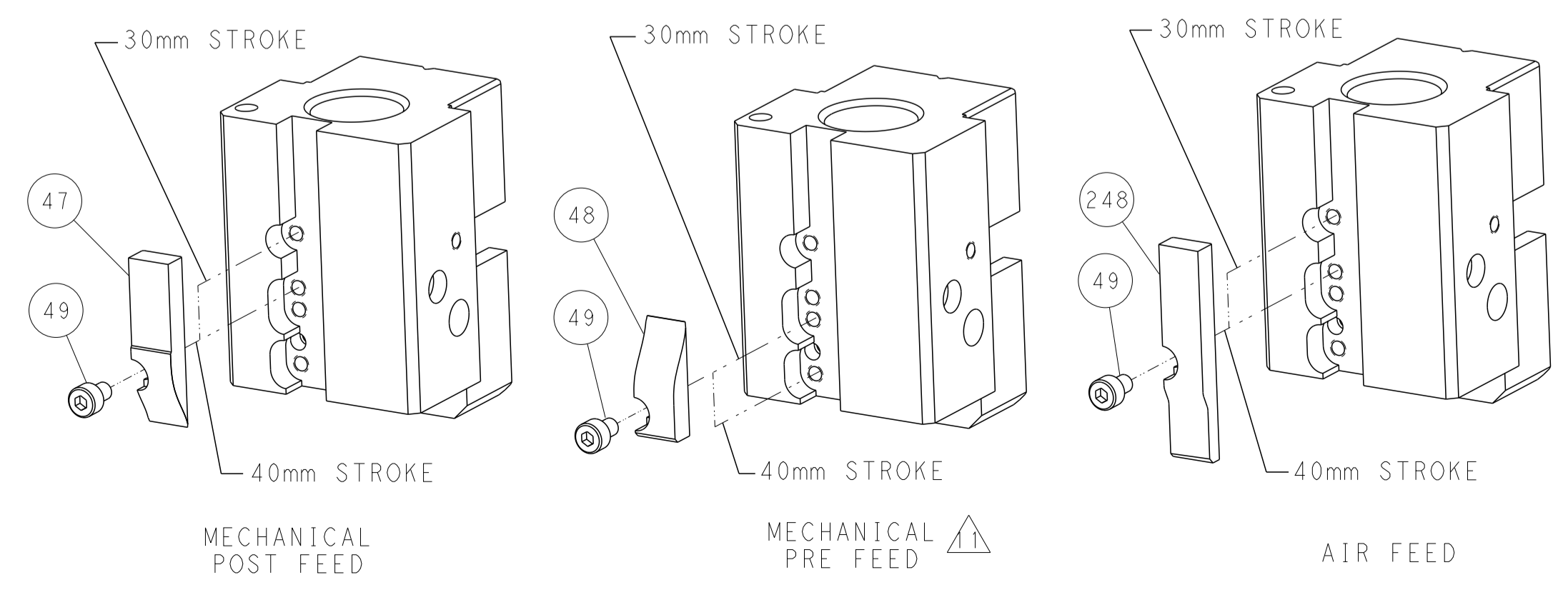

ATLANTIC VERSION
 Shown on sheets 1 of 4 & 2 of 4
 (Pacific version shown on sheets 3 of 4 & 4 of 4)

DIMENSIONS: mm 		TOLERANCES UNLESS OTHERWISE SPECIFIED: 0 PLC ± 1 PLC ± 2 PLC ± 3 PLC ± 4 PLC ± ANGLES ± FINISH		DWN X.ZHAO 14MAR2014 CHK L.ZHANG 14MAR2014 APVD T.ELBIN 14MAR2014 PRODUCT SPEC APPLICATION SPEC WEIGHT SCALE 1:1		NAME Ocean End Feed Applicator SIZE CAGE CODE DRAWING NO. A1 00779 C=2150425 RESTRICTED TO	
MATERIAL:				CUSTOMER ACCESSIBLE PRODUCTION DRAWING		SHEET 2 OF 4 REV F	

PART NUMBER	REVISION	DESCRIPTION	FEED TYPE
2-2150425-1	F	FINE CRIMP HEIGHT ADJUST	MECHANICAL
2-2150425-2	F	FINE CRIMP HEIGHT ADJUST	PNEUMATIC
7-2150425-7	A	CRIMP TOOLING KIT	-

PACIFIC VERSION TERMINATOR
INTERFACE ADAPTER

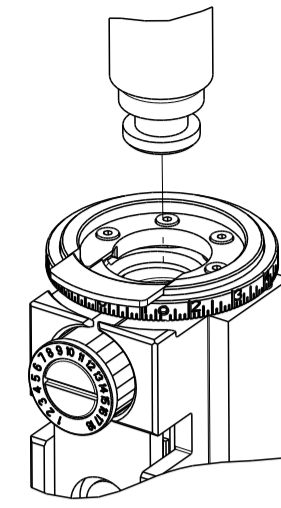

APPLICATOR DATA		
CRIMP	SIZE	TYPE
WIRE	3.56 mm [.140]	F
INSUL	7.11 mm [.280]	F
APPL INSTRUCTIONS 408-35043		

TERMINAL DATA: TE TERMINAL		TE CRIMP SPECIFICATION	
TERMINAL NAME: RECEPTACLE, FASTON, LOW-INSERTION, .250 SERIES			
WIRE STRIP LENGTH .237-.267 IN [6.02-6.78 mm]		INSULATION DIAMETER RANGE Ø.210-.265 IN [5.33-6.73 mm]	
TERMINAL APPLICATION SPECIFICATION	(A)114-2036	-	-
	(B)114-35000	-	-
TERMINALS APPLIED			
TE TERMINAL	TE TERMINAL	TE TERMINAL	TE TERMINAL
(A) 63757-1	(A) 63757-2	(B) 63800-1	

WIRE SIZE	CRIMP HEIGHT mm [INCH]	CRIMP HEIGHT REFERENCE SETTING
12 AWG	2.13+/-0.050 [.084+/- .002]	6.3
14 AWG	1.83+/-0.050 [.072+/- .002]	9.7
(2) 18	1.75+/-0.050 [.069+/- .002]	10.3
16 AWG	1.68+/-0.05 [.066+/- .002]	11.2

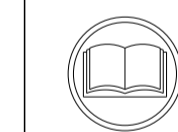

- RECOMMENDED SPARE PARTS
- REFER TO SUPPLIED INSTRUCTION SHEET FOR CLEANING, LUBRICATION AND STORAGE OF APPLICATOR.
- APPLY PART NUMBER 2-23419-6 LOCTITE TO THREADS OF ITEM 242. APPLY PART NUMBER 1-23419-5 LOCTITE TO THREADS OF ITEM 180.
- CRIMP HEIGHT REFERENCE SETTING WAS THE SETTING USED WHEN THE APPLICATOR WAS QUALIFIED AT THE FACTORY. ADJUSTMENT MAY BE NECESSARY WHEN RUNNING APPLICATOR IN THE FIELD.
- TERMINAL LUBRICANT IS RECOMMENDED.
- UNLESS SPECIFIED OTHERWISE TORQUE VALUES SHALL BE USED PER DOCUMENT, 101-35000.
- ITEM #261 FOR (2)18 AWG WIRE SIZES. ITEM #3 FOR ALL OTHER WIRE SIZES.

***WARNING**
ON INSTALLATION, SET WIRE DISC TO CRIMP HEIGHT REFERENCE SETTING FOR LARGEST WIRE SIZE. CRIMP HEIGHT REFERENCE SETTINGS GREATER THAN THE VALUE SHOWN MAY CAUSE DAMAGE TO THE CRIMP TOOLING. REFER TO THE INSTRUCTION SHEET FOR PROPER SETUP AND ADJUSTMENTS.

PACIFIC VERSION
Shown on sheets 3 of 4 & 4 of 4
(Atlantic version shown on sheets 1 of 4 & 2 of 4)

LOC	DIST	REVISIONS					
		P	LTN	DESCRIPTION	DATE	OWN	APVD
A	66	-	-	SEE SHEET 1	-	-	-

1	1	1	3-1803016-1	CRIMPER, INSULATION F	261
-	1	1	2119082-9	CAM, SNAIL, INSULATION ADJUSTMENT	244
-	1	1	2079764-1	WASHER, WAVE SPRING, CREST-TO-CREST	243
3	1	1	2119083-1	RETAINER, INSULATION DIAL	242
-	-	1	2119580-1	MECHANICAL FEED ASSEMBLY	239
-	1	-	2844940-3	AIR FEED MODULE	238
-	1	1	1-18028-0	WASHER, FLAT, REG M8	192
-	4	4	2079383-9	SCR, BHSC, RoHS (M6 X 20)	186
3	1	1	1-1976055-3	STANDOFF, HOLD-DOWN	180
-	1	1	6-993111-6	PIN, SLOTTED SPRING 3.0 X 14.0	177
-	1	1	8-22280-7	SPRING, COMPRESSION	176
-	1	1	1752353-2	GUIDE PIN, HOLDDOWN	175
-	1	1	1901680-2	GUIDE PIN, HOLDDOWN	174
-	REFREF	-	994970-2	COUNTER, MAGNETIC	164
-	1	-	2119641-2	FEED CAM, AIR FEED	152
-	1	1	2168083-8	SCR, SKT HD CAP, RoHS, M4 X 16	144
-	-	1	2119653-2	FEED CAM, POST FEED	142
-	1	1	2119655-6	APPLICATOR BASIC ASSEMBLY, EF	141
-	1	1	1803518-1	RAM ASSEMBLY, EF PACIFIC	140
5	1	1	2119955-2	ASSY, LUBRICATOR, END FEED	84
-	1	1	455888-6	SPACER, CRIMPER	82
-	1	1	1803607-4	DOCUMENTATION PACKAGE	71
-	2	2	2-18032-2	SCR, SET, FLT PNT, M3 X 10.0	70
-	1	1	2119740-1	TAG, IDENTIFICATION	67
-	2	2	2168078-1	SCREW, DRIVE, RH, RoHS, 2 x .188	66
-	1	1	1901681-1	HOLDDOWN, TERMINAL	65
-	2	2	2168400-5	SHCS, LOW HEAD, RoHS, M4 X 20	64
-	-	2	5-18022-5	SCR, HEX HD CAP, M4 X 6.0	59
-	-	1	2063961-1	FEED FINGER	58
-	3	3	2168400-4	SHCS, LOW HEAD, RoHS, M4 X 8	57
-	2	2	1-2168083-0	SCR, SKT HD CAP, RoHS, M4 X 10	56
-	2	2	5018030-1	NUT, HEX, REG, RoHS, M3	54
-	2	2	986965-8	NUT, LOCK, HEX, TORQUE (M4)	53
-	1	1	1-5018030-0	NUT, HEX, REG, RoHS, M3.5	52
-	1	-	2063961-1	FEED FINGER	51
-	1	2	18023-9	SCR, SKT HD CAP M4 X 6.0	49
-	-	1	2119652-1	FEED CAM, PRE FEED	48
-	1	1	1803602-1	SCR, BHSC, RoHS (M8 X 25)	41
-	7	7	1-18028-2	WASHER, FLAT, REG M4	33
-	2	2	2079383-5	SCR, BHSC, RoHS (M4 X 20)	31
-	2	2	2168083-2	SCR, SKT HD CAP, RoHS, M4 X 8.0	29
-	1	1	240639-1	STRIPPER (MACHINING)	27
-	2	2	1-2168083-5	SCR, SKT HD CAP, RoHS, M4 X 30	25
-	1	1	1-1752371-6	PLATE, STRIP GUIDE	24
-	1	1	240825-8	PLATE, STRIP HOLD DOWN	23
-	2	2	2-22281-3	SPRING, COMPRESSION	22
-	1	1	1803292-4	DRAG	20
-	2	2	1901259-6	GUIDE, LOWER STRIP	18
-	1	1	240641-9	SPACER	16
-	1	1	1752360-1	SPACER, HOLD-DOWN	13
1	1	1	240644-9	PLATE, REAR SHEAR	11
-	-	-	-	-	10
1	1	1	5-690482-9	PLATE, FRONT SHEAR	9
1	1	1	4-1803000-6	ANVIL, COMBINATION, END FEED	8
1	1	1	1-2217206-3	BLADE, SLUG	7
-	-	-	-	-	6
-	1	1	240641-8	SPACER	5
-	1	1	238011-2	BLOCK, CRIMPER SPACER	4
7	1	1	3-1803016-4	CRIMPER, INSULATION F	3
-	1	1	1-455888-0	SPACER, CRIMPER	2
1	1	1	456425-8	CRIMPER, WIRE .140 F PREMIUM	1
-	77	22	21	PART NO	ITEM NO

DIMENSIONS:		TOLERANCES UNLESS OTHERWISE SPECIFIED:		DRAWN		DATE	
mm	0 PLC ±	1 PLC ±	2 PLC ±	X. ZHAO	14MAR2014	CHK	14MAR2014
	3 PLC ±	4 PLC ±	ANGLES ±	L. ZHANG		APVD	14MAR2014
	FINISH			T. ELBIN		NAME	
MATERIAL						TE Connectivity Harrisburg, PA 17105-3608	
						Ocean End Feed Applicator	
				SIZE	CAGE CODE	DRAWING NO	RESTRICTED TO
				A1	00779	©=2150425	
				WEIGHT		SCALE	SHEET 3 OF 4
						Customer Accessible Production Drawing	REV F

LOC	DIST	REV	DESCRIPTION	DATE	OWN	APVD
A	66		SEE SHEET 1			

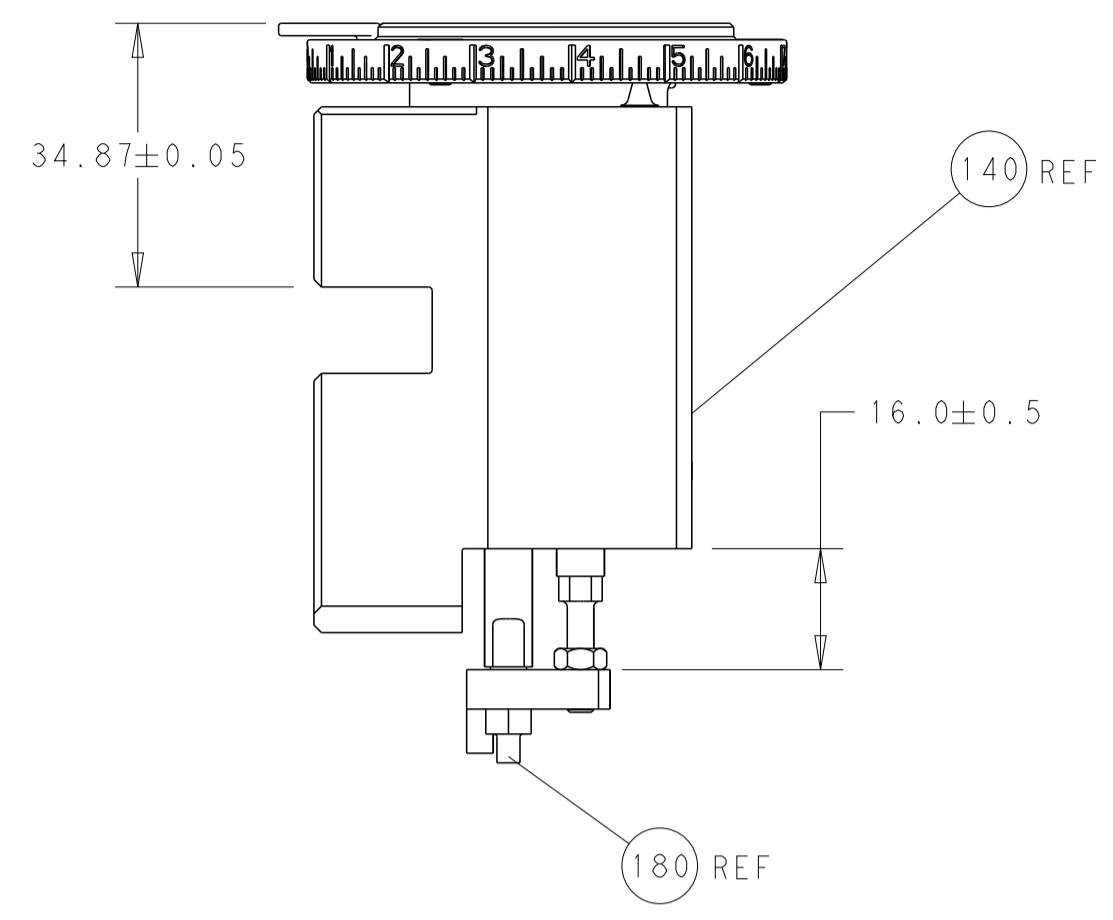

RAM AND HOLDDOWN SET-UP

FEED TYPE
MECHANICAL

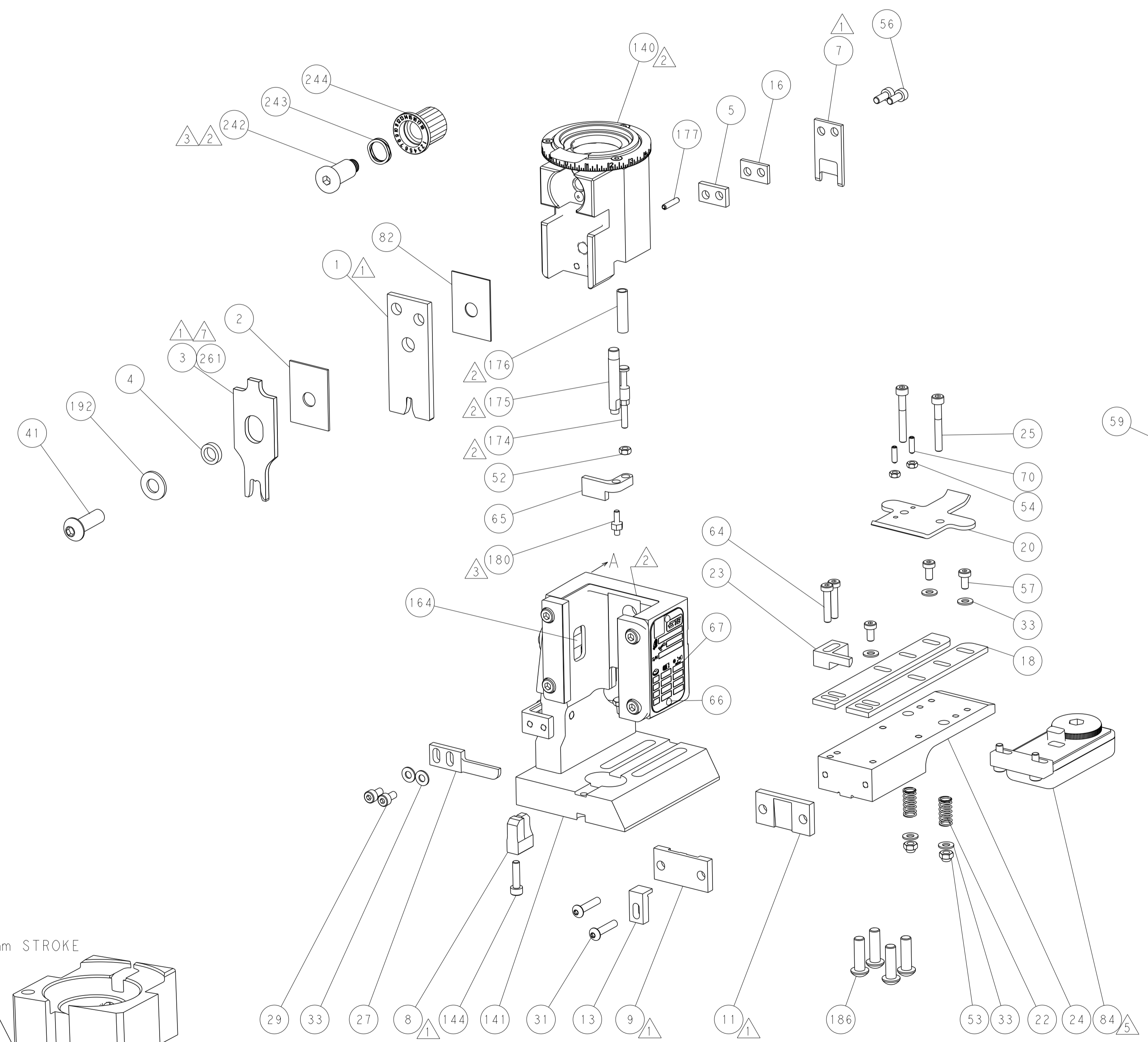
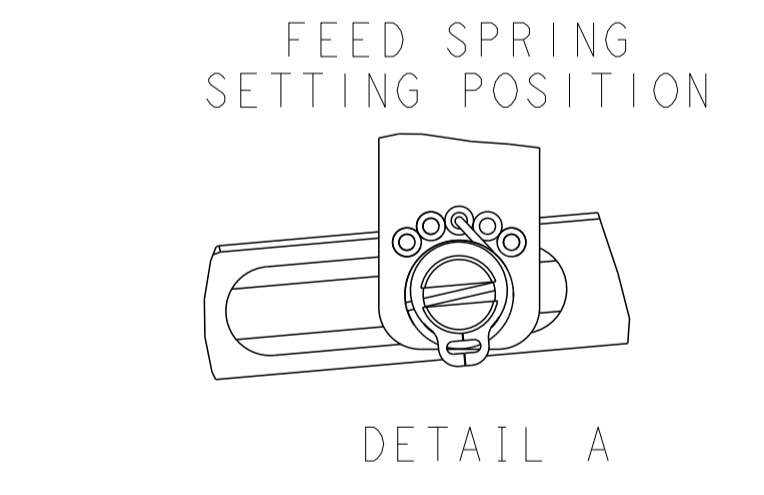
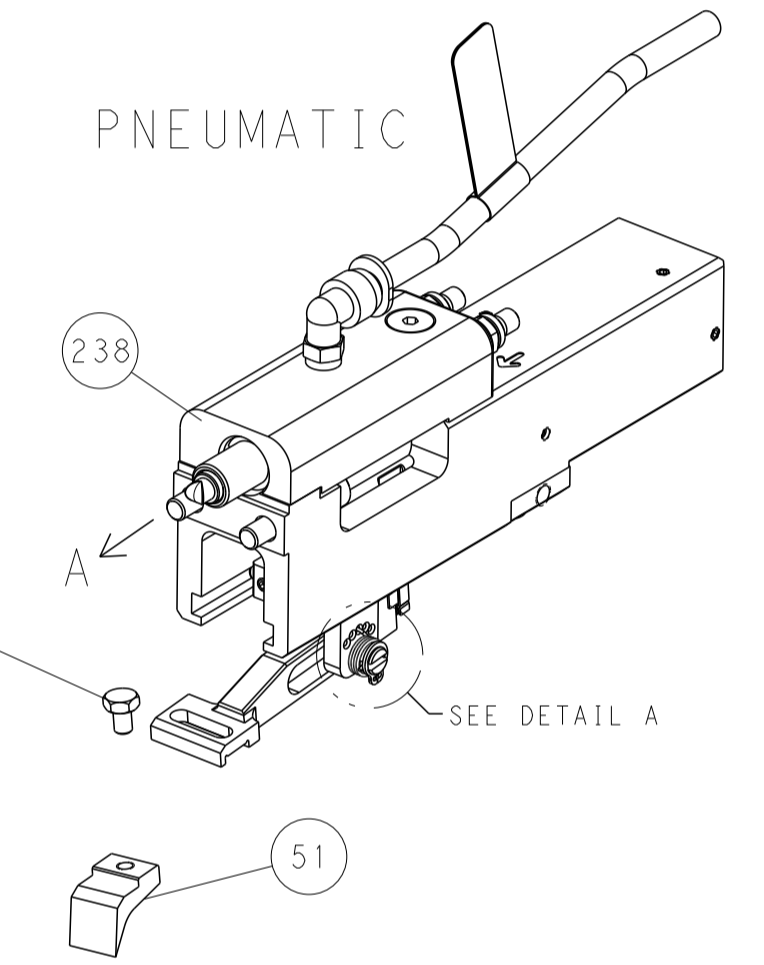
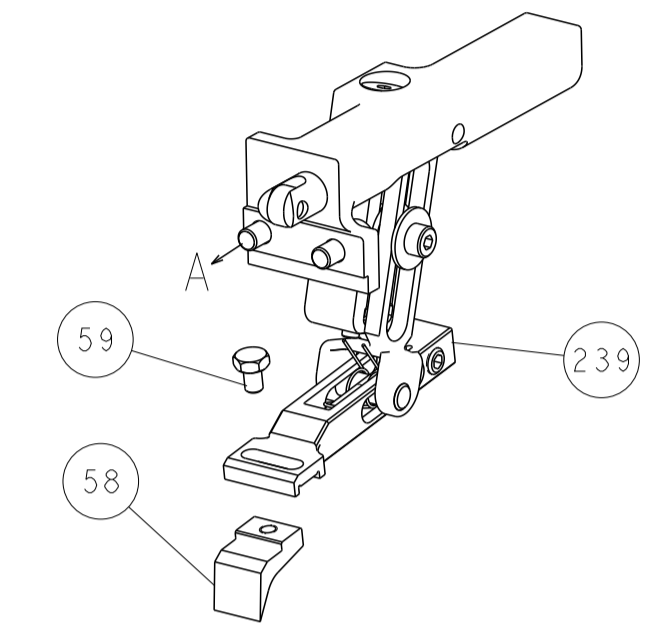

CAM POSITIONS

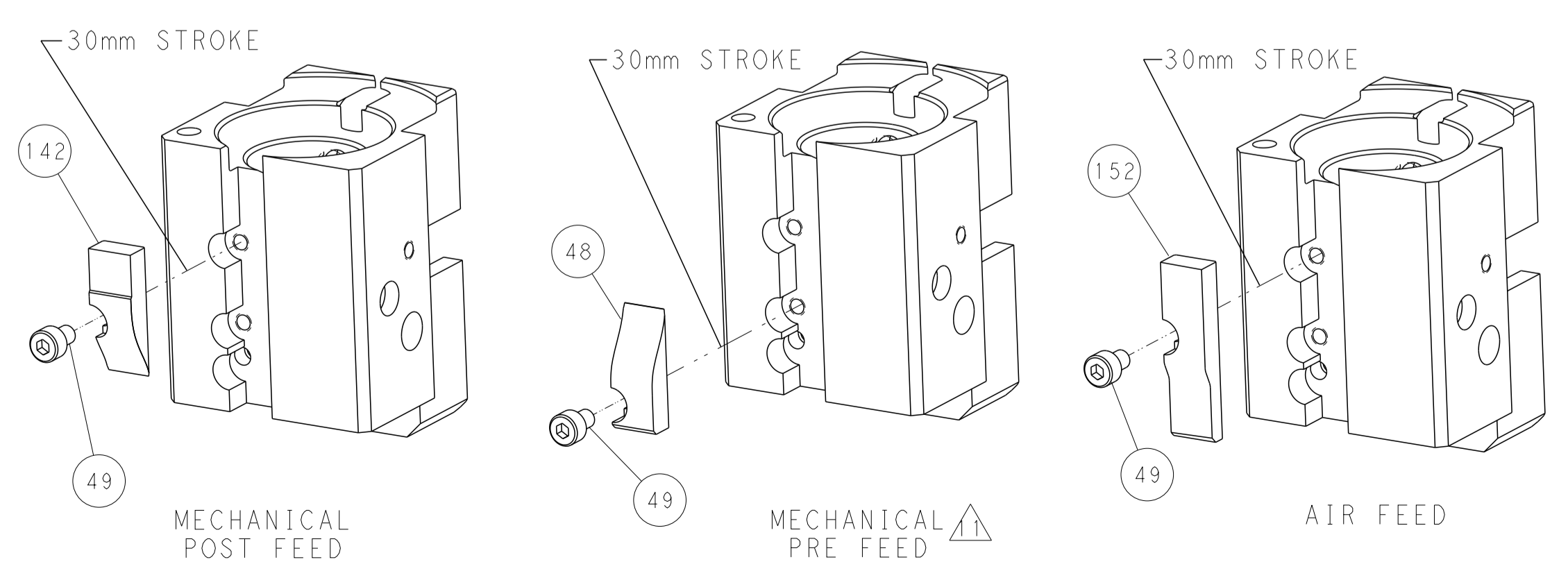

PACIFIC VERSION
 Shown on sheets 3 of 4 & 4 of 4
 (Atlantic version shown on sheets 1 of 4 & 2 of 4)

DIMENSIONS: mm 		TOLERANCES UNLESS OTHERWISE SPECIFIED: 0 PLC ± 1 PLC ± 2 PLC ± 3 PLC ± 4 PLC ± ANGLES ± FINISH		DWN X. ZHAO 14MAR2014 CHK L. ZHANG 14MAR2014 APVD T. ELBIN 14MAR2014		NAME Ocean End Feed Applicator	
MATERIAL:		WEIGHT:		SIZE: A1 CAGE CODE: 00779 DRAWING NO: C-2150425		RESTRICTED TO:	
Customer Accessible Production Drawing				SCALE: 1:1		SHEET 4 OF 4 REV F	