

DO NOT SCALE FROM THIS PRINT

ALL DIMENSIONS ARE REFERENCE (SEE T-1M44-XXXX-XX FOR CONTROL PRINT)

T1M44-X-XXXX-01-XX

SUPPLIED
 *-L: LOOSE
 -R: REEL
 -M: MINI REEL

PLATING SPECIFICATION
 -GF: 3µ" GOLD FLASH IN CONTACT AREA,
 3µ" GOLD ON TAIL
 -G: 10µ" LIGHT GOLD IN CONTACT AREA,
 3µ" GOLD ON TAIL
 -H: 30µ" HEAVY GOLD IN CONTACT AREA,
 3µ" GOLD ON TAIL

LEAD STYLE
 -2830: 28-30 AWG

(* = FOR EXISTING CUSTOMERS ONLY)

CARRIER SPECIFICATIONS

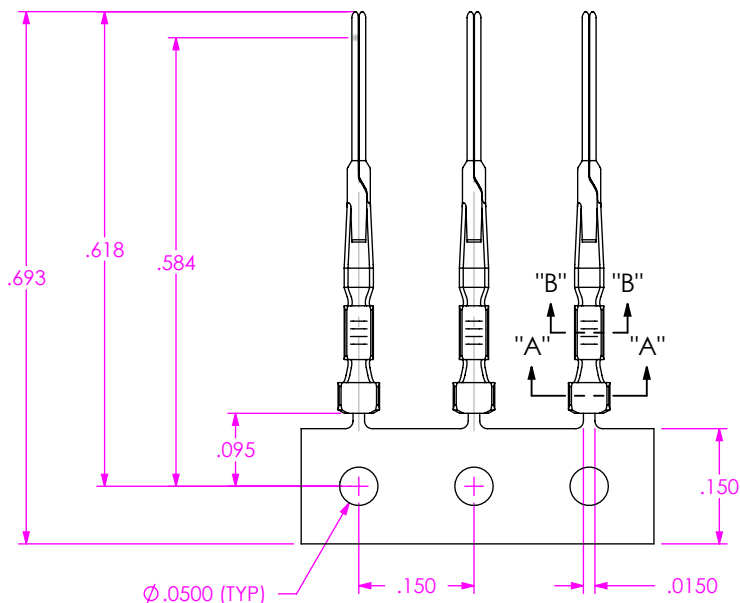
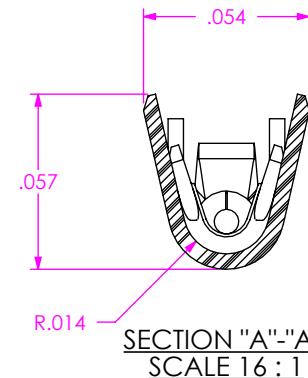
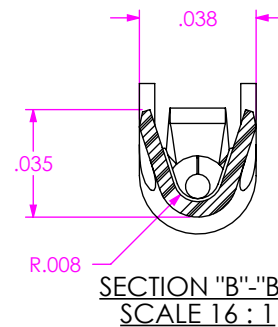
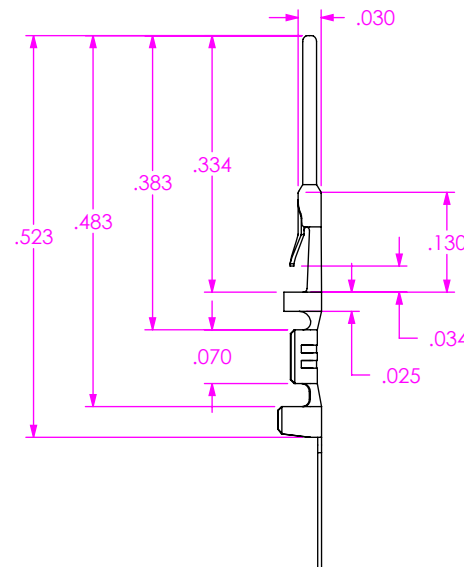



FIG 1
 (T-1M44-2830-01-XX SHOWN)



- NOTES:
1. PLATED T-1MM PARTS ARE TO BE UNWOUND THEN REWOUND AND COUNTED, POSITIONED AS SHOWN ON SAMTEC REEL WITH VIEWPORTS, LABELED T1M44 WITH APPROPRIATE PLATE CALL OUT AND LABEL PLACED AS SHOWN.
 2. MAXIMUM ALLOWABLE SPLICES PER REEL:
 -R: 2
 -M: 1
 3. SPLICES ARE NOT TO BE CONNECTED.
 4. NUMBER OF SPLICES TO BE MARKED ON EACH REEL.
 5. REELED PARTS TO BE INTERLEAVED WITH PAPER BETWEEN EACH LAYER OF PARTS.
 6. ALLOWABLE INTERLEAF SPLICES PER REEL:
 -R: 3
 -M: 1
 7. SECURELY CONNECT INTERLEAF SPLICE.
 8. OUTER WRAP SHALL RECEIVE RB-24-1.00-P PROTECTIVE REEL BAND.
 9. DUE TO PLATING REQUIREMENTS CONTACT SAMPLES MAY BE REMOVED INTERMITTINGLY FROM THE BANDOLIER RESULTING IN SMALL GAPS BUT DOES NOT AFFECT FINAL COUNT.
 10. QTY PER REEL:
 -R: 35,000 +100/-0 PCS
 -M: 5,000 +300/-0 PCS

| | | |
|---|----------------------|---|
| UNLESS OTHERWISE SPECIFIED, DIMENSIONS ARE IN INCHES. TOLERANCES ARE: DECIMALS ANGLES | | <p>PROPRIETARY NOTE</p> <p>THIS DOCUMENT CONTAINS CONFIDENTIAL AND PROPRIETARY INFORMATION AND ALL DESIGN, MANUFACTURING, REPRODUCTION, USE, PATENT RIGHTS AND SALES RIGHTS ARE EXPRESSLY RESERVED BY SAMTEC, INC. THIS DOCUMENT SHALL NOT BE DISCLOSED, IN WHOLE OR PART, TO ANY UNAUTHORIZED PERSON OR ENTITY NOR REPRODUCED, TRANSFERRED OR INCORPORATED IN ANY OTHER PROJECT IN ANY MANNER WITHOUT THE EXPRESS WRITTEN CONSENT OF SAMTEC, INC.</p> |
| MATERIAL: BeCu | DO NOT SCALE DRAWING | SHEET SCALE: 8:1 |
| THICKNESS: .0050 | | |
| F:\DWG\MISC\MKTG\T1M44-X-XXXX-01-XX-MKT.SLDDRW | | |

| | |
|---|-----------------------------------|
|  520 PARK EAST BLVD, NEW ALBANY, IN 47150 PHONE: 812-944-6733 FAX: 812-948-5047 e-Mail: info@SAMTEC.com code: 55322 | |
| DESCRIPTION: | .050" C.L. DISCRETE WIRE TERMINAL |
| DWG. NO. | T1M44-X-XXXX-01-XX |
| BY: G. PURVIS 12/21/2007 | SHEET 1 OF 2 |

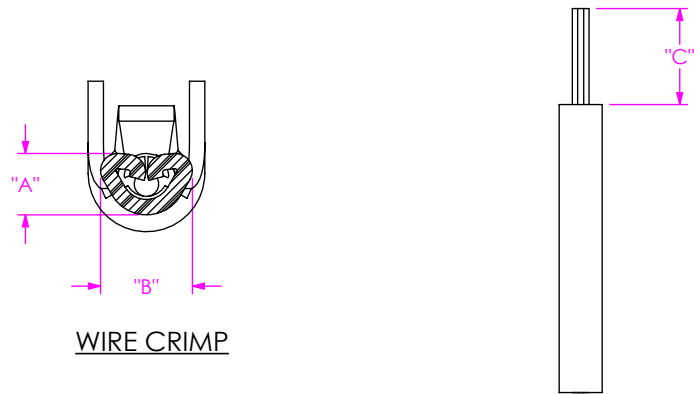

WIRE CRIMP

INSULATION STRIP LENGTH

| TABLE 1 | | | | | | | |
|----------------|-----|-------------|---------------|--------|--------|-------|-------------------|
| P/N | AWG | STRANDS/AWG | INSULATION OD | "A" | "B" | "C" | PULL FORCES (LBS) |
| T-1M44-2830-XX | 30 | 7/38 | .0290-.0380 | 0.0170 | 0.0300 | 0.105 | 1.5 |
| | 28 | 7/36 | | 0.0180 | 0.0300 | | 2 |

FIG 2
RECOMMENDED PROCESSING

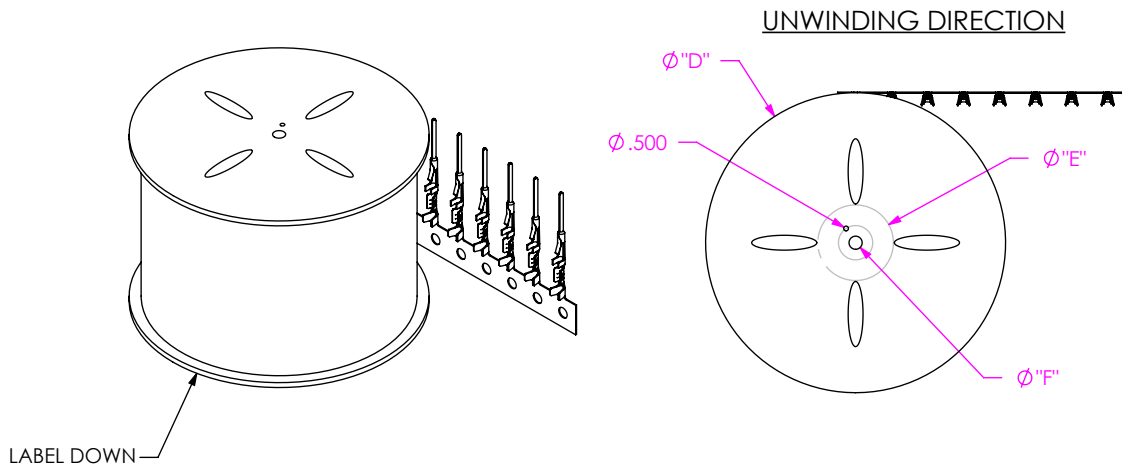

UNWINDING DIRECTION

LABEL DOWN

FIG 3
REEL SPECIFICATIONS

| TABLE 2 | | | | |
|----------|-------------------|------|-------|-------|
| SUPPLIED | REEL PART NUMBER | "D" | "E" | "F" |
| -R | R-24-05.00-1.00-P | 24.0 | 5.50 | 1.125 |
| -M | MR-13.0-4.00-24 | 12.0 | 5.375 | 1.000 |

PROPRIETARY NOTE
 THIS DOCUMENT CONTAINS CONFIDENTIAL AND PROPRIETARY INFORMATION AND ALL DESIGN, MANUFACTURING, REPRODUCTION, USE, PATENT RIGHTS AND SALES RIGHTS ARE EXPRESSLY RESERVED BY SAMTEC, INC. THIS DOCUMENT SHALL NOT BE DISCLOSED, IN WHOLE OR PART, TO ANY UNAUTHORIZED PERSON OR ENTITY NOR REPRODUCED, TRANSFERRED OR INCORPORATED IN ANY OTHER PROJECT IN ANY MANNER WITHOUT THE EXPRESS WRITTEN CONSENT OF SAMTEC, INC.

DO NOT SCALE DRAWING

SHEET SCALE: 8:1



520 PARK EAST BLVD, NEW ALBANY, IN 47150
 PHONE: 812-944-6733 FAX: 812-948-5047
 e-Mail: info@SAMTEC.com code: 55322

DESCRIPTION: .050" C.L. DISCRETE WIRE TERMINAL

DWG. NO. T1M44-X-XXXX-01-XX

BY: G. PURVIS 12/21/2007 SHEET 2 OF 2