

SS-5

250 V Subminiature, radial leaded, time-delay fuses

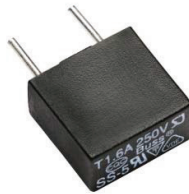

Product description

- Radial leaded, time delay with low breaking capacity
- Designed to IEC60127-3 Sheet 4
- Plastic cap and base, flammability UL 94V0
- Protects against harmful overcurrents in primary and secondary applications
- Small rectangular-leaded design utilizes less board space
- High frequency vibration: MIL-STD-202F, Method 201A
- Halogen free, lead free, RoHS compliant

Applications

Primary and secondary circuit protection:

- Power supplies
- Notebooks and laptops
- Appliances and white goods
- Lighting ballasts
- Power adapters
- Set top boxes
- LED/LCD televisions and displays
- Air conditioners
- Battery chargers

Agency information

- UL Recognition: File E19180, Guide JDYX2/JDYX8
- VDE: 40015513
- CQC: 08012025533
- PSE:
JET 1641-31007-1008 (1 A – 5 A)
JET 1641-31007-1009 (6.3 A)
- KC:
SU05011-8001 (400 mA – 800 mA)
SU05011-8002 (1 A – 2.5 A)
SU05011-8003 (3.15 A – 6.3 A)
- Semko:
1516697 (630 mA, 1 A – 4 A)
1124941 (500 mA, 800 mA, 5 A, 6.3 A)

Ordering

- Use ordering number (see page 6 for details)

Packaging suffixes

- -AP (1 000 parts Ammo pack, Pitch = 12.7)
- -BK (200 parts in a polybag, Lead L = 4.3 ± 0.3)
- -BK2 (200 parts in a polybag, Lead L = 21 ± 3.0)

Electrical characteristics

I_n	1.5I _n minimum minute	2.1I _n maximum minute	2.75I _n minimum ms	2.75I _n maximum s	4I _n minimum ms	4I _n maximum s	10I _n minimum ms	10I _n maximum ms
200 mA – 6.3 A	60	2	400	10	150	3	20	150

Product specifications

Part number	Current rating (A)	Voltage rating (V _{AC})	Interrupting rating at rated voltage ¹ (50 Hz) (A _{AC})	Typical DC cold resistance ² (mΩ)	Typical melting ³ I ² t (A ² s)	Typical voltage drop ⁴ (mV)	cURus	KC	VDE	CQC	SEMKO	PSE+ JET ¹
SS-5-200mA	0.2	250	35	960	0.35	212	X		X	X		
SS-5-400mA	0.4	250	35	330	1.67	147	X	X	X	X		
SS-5-500mA	0.5	250	35	258	1.79	152	X	X	X	X	X	
SS-5-630mA	0.63	250	35	140	1.51	101	X	X	X	X	X	
SS-5-800mA	0.8	250	35	118	4.21	111	X	X	X	X	X	
SS-5-1A	1.0	250	35	80.8	7.40	94.5	X	X	X	X	X	X
SS-5-1.25A	1.25	250	35	62.4	12.8	93.5	X	X	X	X	X	X
SS-5-1.6A	1.6	250	35	41	23	71.5	X	X	X	X	X	X
SS-5-2A	2.0	250	35	31.2	29.8	75	X	X	X	X	X	X
SS-5-2.5A	2.5	250	35	24.3	40.3	74.5	X	X	X	X	X	X
SS-5-3.15A	3.15	250	35	16.8	67	62.5	X	X	X	X	X	X
SS-5-4A	4.0	250	40	12.8	87	65.4	X	X	X	X	X	X
SS-5-5A	5.0	250	50	7.35	120	43	X	X	X	X	X	X
SS-5-6.3A	6.3	250	63	7.4	176	59	X	X	X	X	X	X

- 200 mA to 3.15 A measured at 35 A, 95% - 100% of PF on AC. 4 A – 6.3 A measured at 10 times of rating current 95% - 100% of PF on AC.
- Typical cold resistance measured at < 10% of rated current
- I²t value is measured at 10I_n DC
- Typical voltage drop measured at 20 °C ambient temperature and rated current

Dimensions and packaging – mm [in]

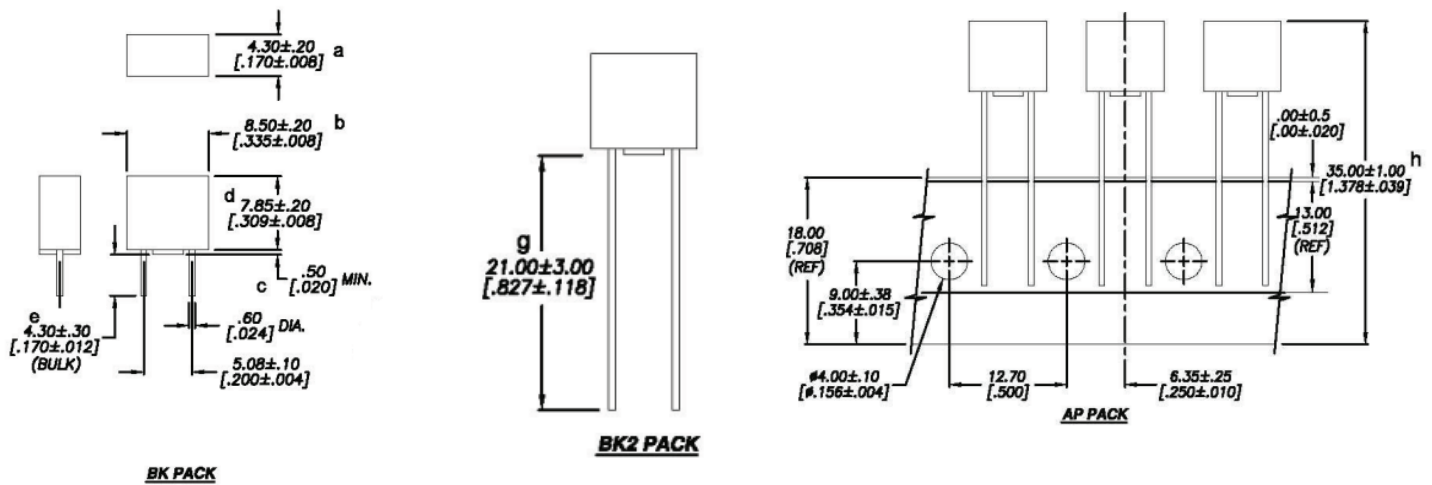

Time vs. current curve

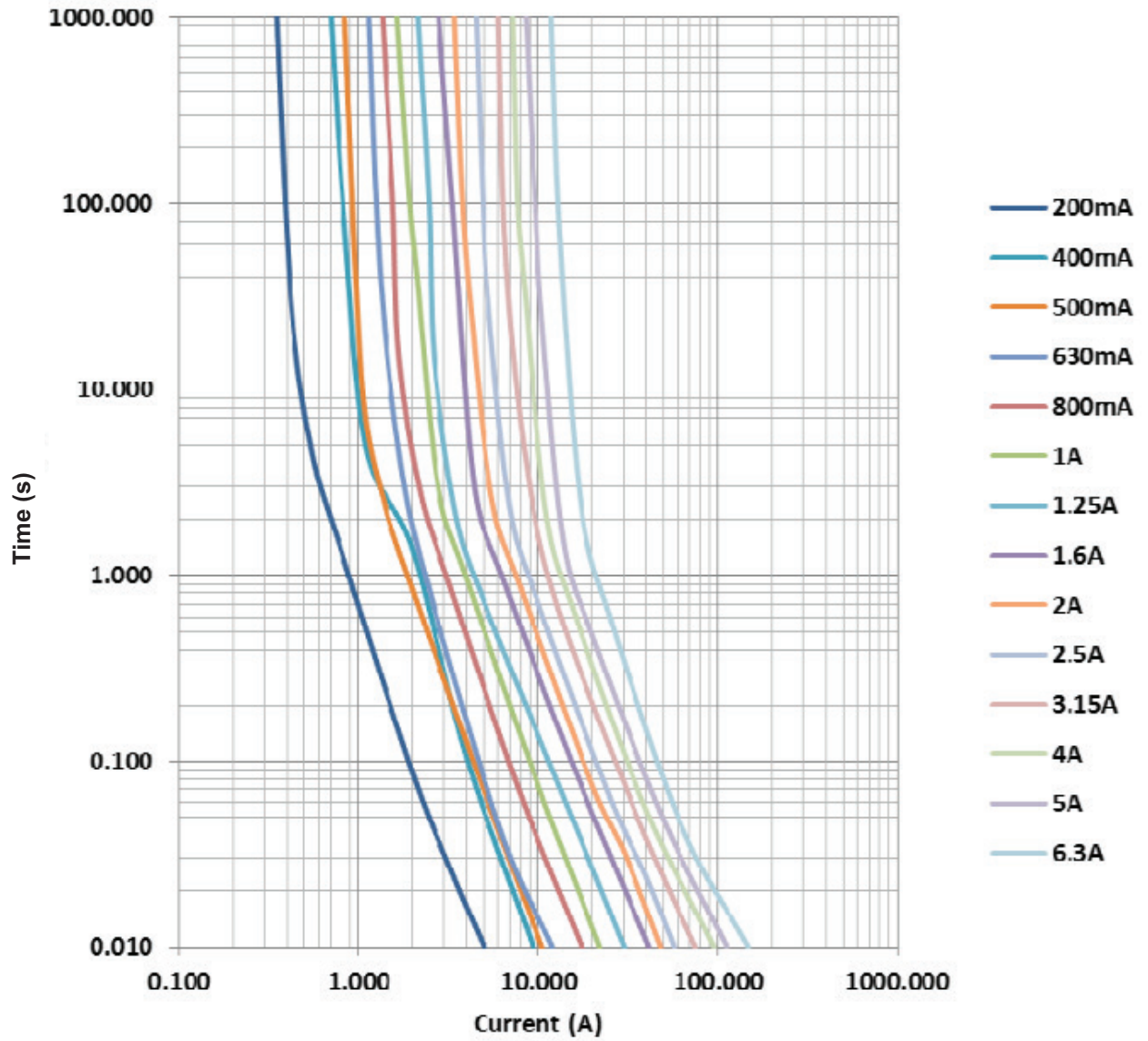

I²t vs. time curve

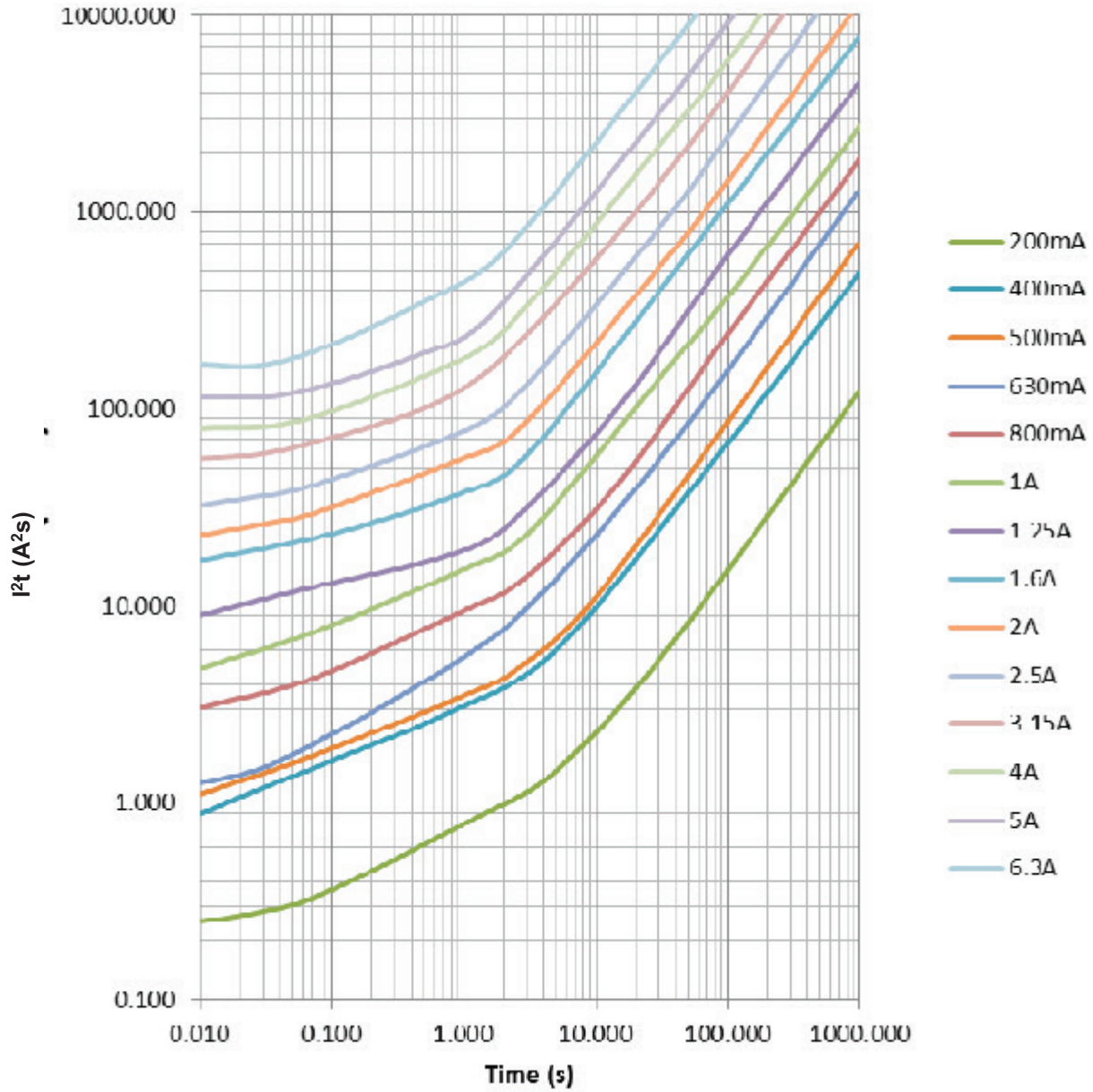

Temperature derating curve

Normal Operating Temperature: +25 °C ±2 °C

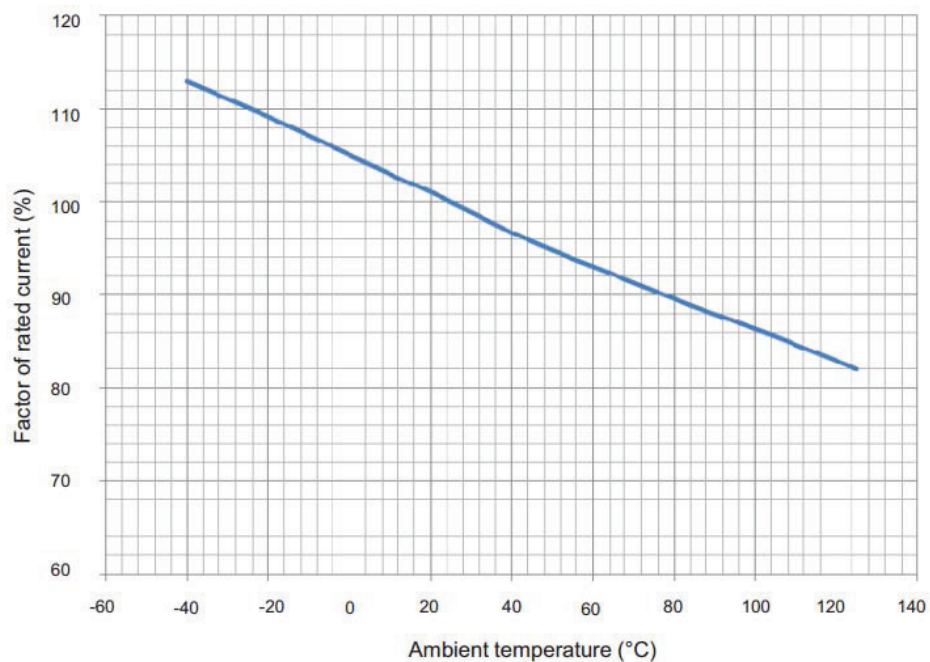

Environmental data

Operating temperature: -40 °C to +125 °C with proper correction factor applied

Storage temperature: -10 °C to 40 °C

Solderability: EIA-186-9E Method 9

High frequency vibration test: Withstands 10-55 Hz per MIL-STD-202F, Method 201A

Endurance test: IEC60127-3/4

Ordering codes

The ordering code is the part number replacing the “.” with a “-” plus adding the packaging suffix.

Packaging suffixes

- -AP (1 000 parts Ammo pack, Pitch = 12.7)
- -BK (200 parts in a polybag, Lead L = 4.3 ± 0.3)
- -BK2 (200 parts in a polybag, Lead L = 21 ± 3.0)

Part number	Ordering codes		
	-AP option	-BK option	-BK2 option
SS-5-200mA	SS-5-200mA-AP	SS-5-200mA-BK	SS-5-200mA-BK2
SS-5-400mA	SS-5-400mA-AP	SS-5-400mA-BK	SS-5-400mA-BK2
SS-5-500mA	SS-5-500mA-AP	SS-5-500mA-BK	SS-5-500mA-BK2
SS-5-630mA	SS-5-630mA-AP	SS-5-630mA-BK	SS-5-630mA-BK2
SS-5-800mA	SS-5-800mA-AP	SS-5-800mA-BK	SS-5-800mA-BK2
SS-5-1A	SS-5-1A-AP	SS-5-1A-BK	SS-5-1A-BK2
SS-5-1.25A	SS-5-1-25A-AP	SS-5-1-25A-BK	SS-5-1-25A-BK2
SS-5-1.6A	SS-5-1-6A-AP	SS-5-1-6A-BK	SS-5-1-6A-BK2
SS-5-2A	SS-5-2A-AP	SS-5-2A-BK	SS-5-2A-BK2
SS-5-2.5A	SS-5-2-5A-AP	SS-5-2-5A-BK	SS-5-2-5A-BK2
SS-5-3.15A	SS-5-3-15A-AP	SS-5-3-15A-BK	SS-5-3-15A-BK2
SS-5-4A	SS-5-4A-AP	SS-5-4A-BK	SS-5-4A-BK2
SS-5-5A	SS-5-5A-AP	SS-5-5A-BK	SS-5-5A-BK2
SS-5-6.3A	SS-5-6-3A-AP	SS-5-6-3A-BK	SS-5-6-3A-BK2

Wave solder profile

Reflow soldering not recommended

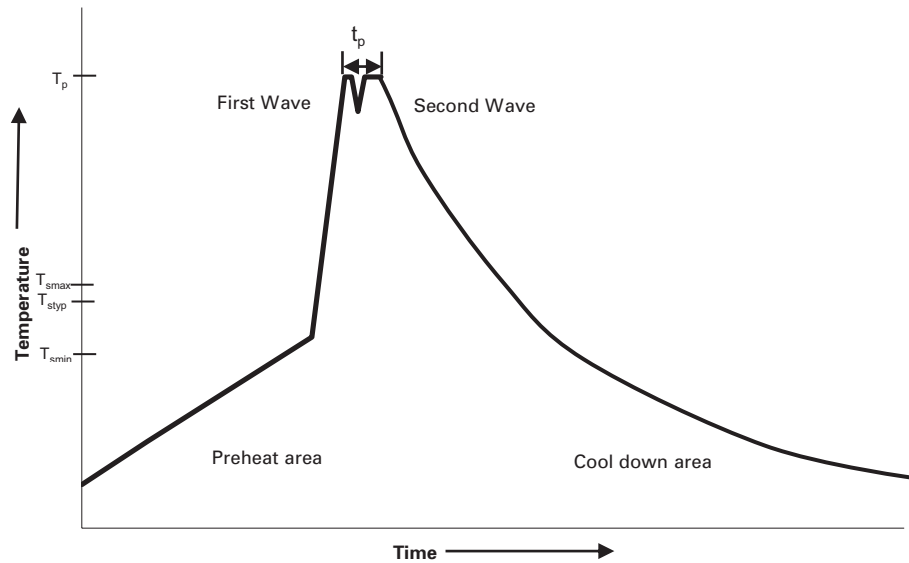

Reference EN 61760-1:2006

Profile Feature	Standard SnPb Solder	Lead (Pb) Free Solder
Preheat	• Temperature min. (T_{smin})	100°C
	• Temperature typ. (T_{styp})	120°C
	• Temperature max. (T_{smax})	130°C
	• Time (T_{smin} to T_{smax}) (t_s)	70 seconds
Δ preheat to max Temperature	150°C max.	150°C max.
Peak temperature (T_p)*	235°C – 260°C	250°C – 260°C
Time at peak temperature (t_p)	10 seconds max 5 seconds max each wave	10 seconds max 5 seconds max each wave
Ramp-down rate	~ 2 K/s min ~3.5 K/s typ ~5 K/s max	~ 2 K/s min ~3.5 K/s typ ~5 K/s max
Time 25°C to 25°C	4 minutes	4 minutes

Manual solder

350°C, 4-5 seconds (by soldering iron), generally manual hand soldering is not recommended.

Life Support Policy: Eaton does not authorize the use of any of its products for use in life support devices or systems without the express written approval of an officer of the Company. Life support systems are devices which support or sustain life, and whose failure to perform, when properly used in accordance with instructions for use provided in the labeling, can be reasonably expected to result in significant injury to the user.

Eaton reserves the right, without notice, to change design or construction of any products and to discontinue or limit distribution of any products. Eaton also reserves the right to change or update, without notice, any technical information contained in this bulletin.

Eaton
Electronics Division
1000 Eaton Boulevard
Cleveland, OH 44122
United States
www.eaton.com/elx

© 2016 Eaton
All Rights Reserved
Printed in USA
Publication No. 2621 BU-MC16007
January 2016