

ATLANTIC VERSION TERMINATOR INTERFACE ADAPTER	PART NUMBER	REVISION	DESCRIPTION	FEED TYPE	APPLICATOR STYLE CONVERSION CHART						
					CONVERT TO	PART NUMBERS REQUIRED					
	2150468-1	A	FINE CRIMP HEIGHT ADJUST	MECHANICAL	PNEUMATIC FEED	2119950-1	2119792-2	-	2119641-1	-	2063440-1
					SERVO LATCH PLATE	2119951-1	1901697-1	8-2150468-5	-	-	2168400-7 (QUANTITY 2)
					SMART APPLICATOR	2161326-1	-	8-2150468-4	-	-	-
	2150468-2	A	FINE CRIMP HEIGHT ADJUST	PNEUMATIC	MECHANICAL FEED	2119949-1	2063961-1	5-18022-5	2119653-1	-	-
					SERVO LATCH PLATE	2119951-1	1901697-1	8-2150468-5	-	-	2168400-7 (QUANTITY 2)
	2150468-5	A	FINE CRIMP HEIGHT ADJUST	SERVO LATCH PLATE	MECHANICAL FEED	2119949-1	2063961-1	5-18022-5	2119653-1	-	-
					PNEUMATIC FEED	2119950-1	2119792-2	-	2119641-1	-	2063440-1
2150468-6	A	NON-CRIMP HEIGHT ADJUST	SERVO LATCH PLATE	-	-	-	-	-	-	-	
2150468-7	A	FINE CRIMP HEIGHT ADJUST	NONE	-	-	-	-	-	-	-	
7-2150468-7	A	CRIMP TOOLING KIT	-	-	-	-	-	-	-	-	

APPLICATOR DATA		
CRIMP	SIZE	TYPE
WIRE	2.03 mm [.080]	F
INSUL	2.40 mm [.094]	F
APPL INSTRUCTIONS 408-10390		

TERMINAL DATA: STOCKO TERMINAL STOCKO CRIMP SPECIFICATION			
TERMINAL NAME: TERMINAL			
WIRE STRIP LENGTH		INSULATION DIAMETER RANGE	
3.00-4.00 mm [.118-.157 IN]		Ø 2.80 mm [.110 IN] MAX	
TERMINAL APPLICATION SPECIFICATION F129 Rev -			
TERMINALS APPLIED			
TE TERMINAL	STOCKO TERMINAL	TE TERMINAL	STOCKO TERMINAL
2113552-1	RSB7990.001 F 2.8-1		

WIRE SIZE	CRIMP HEIGHT mm [INCH]	CRIMP HEIGHT REFERENCE SETTING
1.00mm2	1.21+/-0.02 [.048+/- .001]	6.4
0.75mm2	1.13+/-0.02 [.044+/- .001]	7.1
20 AWG OR 0.50mm2	1.06+/-0.02 [.042+/- .001]	7.9

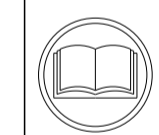

- 1 RECOMMENDED SPARE PARTS
- 2 GREASE BEARING SURFACES LIGHTLY
- 3 LUBRICATE DAILY PER THE APPLICATOR INSTRUCTION SHEET SUPPLIED WITH THE APPLICATOR.
- 4 APPLICATOR SPECIFIC DATA TO BE ENTERED INTO BLANK MEMORY CHIP AT ASSEMBLY. SEE BELOW FOR PART NUMBER:
 MECHANICAL FEED WITH "SMART APPLICATOR" CONVERSION: 8-2150468-4
 PNEUMATIC FEED WITH "SMART APPLICATOR" CONVERSION: 8-2150468-4
 SERVO FEED WITH "FINE CRIMP HEIGHT ADJUST": 8-2150468-5
 SERVO FEED WITH "NON-CRIMP HEIGHT ADJUST": 8-2150468-6
- 5 ADJUSTMENT OF THE STRIPPER MAY BE REQUIRED WHEN MOVING THE APPLICATOR BETWEEN BENCH AND LEADMAKER APPLICATIONS.
- 6 APPLY PART NUMBER 1-23419-5 LOCTITE TO THREADS OF ITEMS 62 & 180. APPLY PART NUMBER 2-23419-6 LOCTITE TO THREADS OF ITEM 242. FOR -6 ONLY APPLY PART NUMBER 1-23419-5 LOCTITE TO THREADS OF ITEMS 37 & 180.
- 7 GREASE THREADS, GROOVE AND O-RING ON ITEMS 35 & 252.
- 8 MAGNET, ITEM 166 MUST BE ORIENTED CORRECTLY IN ORDER TO PROPERLY ACTUATE THE COUNTER.
- 9 CRIMP HEIGHT REFERENCE SETTING WAS THE SETTING USED WHEN THE APPLICATOR WAS QUALIFIED AT THE FACTORY. ADJUSTMENT MAY BE NECESSARY WHEN RUNNING APPLICATOR IN THE FIELD.
- 10 SPARE FEED CAM STORAGE LOCATION REFER TO INSTRUCTION SHEET FOR ADDITIONAL INFORMATION.
- 11 THE RECOMMENDED SET-UP FOR END FEED APPLICATORS IS POST-FEED WITH ITEM 2119653-1. THE APPLICATOR CAN BE CONFIGURED FOR PRE-FEED WITH ITEM 2119652-1 BUT MAY ENCOUNTER PROBLEMS WITH SOME APPLICATIONS. FEED ISSUES OR TERMINAL JAMMING MAY OCCUR IN THE PRE-FEED CONFIGURATION.
- 12 WHEN ASSEMBLING -6 NON-CRIMP HEIGHT ADJUST APPLICATOR USE SHIM PACK 2119957-2 TO ALIGN APPLICATOR'S MAXIMUM WIRE CRIMP HEIGHT AT NORMAL TERMINATOR SHUT HEIGHT

***WARNING**
 ON INSTALLATION, SET WIRE DISC, ITEM 40 TO LARGEST WIRE SIZE SETTING. USE OF SETTINGS BELOW MINIMUM REQUIRED CRIMP HEIGHT SETTING WILL CAUSE DAMAGE TO CRIMP TOOLING.

-	-	1	-	-	-	2119957-2	APPLICATOR SHIM PACK	260
-	1	-	1	1	1	8-21084-0	O-RING, .676 ID, .070 DIA. MAT.	252
-	-	-	1	-	-	2119640-1	PUSH ROD, AIR FEED	250
-	-	-	1	-	-	2079988-1	BUSHING, LCH5-12, MISUMI	249
-	-	-	1	-	-	2119641-1	FEED CAM, AIR FEED	248
-	1	-	1	1	1	2119798-1	DETENT PIN	247
-	1	-	1	1	1	1-22279-3	SPRING, COMPRESSION	246
-	-	1	-	-	-	2119759-1	RAM, AMP STYLE, END FEED, NON-ADJUST	245
-77	-7	-6	-5	-2	-1	PART NO	DESCRIPTION	ITEM NO

ATLANTIC VERSION
 Shown on sheets 1 of 4 & 2 of 4
 (Pacific version shown on sheets 3 of 4 & 4 of 4)

SET UP GAUGE	LOC	DIST	REVISIONS			
			REV	DATE	BY	APPD
2119599-2	A	66	1	25AUG2014	RK	GB

-	1	1	1	1	1	2119082-3	CAM, SNAIL, INSULATION ADJUSTMENT	244	
-	1	1	1	1	1	2079764-1	WASHER, WAVE SPRING, CREST-TO-CREST	243	
-	1	1	1	1	1	2119083-1	RETAINER, INSULATION DIAL	242	
-	-	2	2	-	-	2168400-7	SHCS, LOW HEAD, RoHS, M5 X 10	240	
-	-	-	-	-	1	2119580-1	MECHANICAL FEED ASSEMBLY	239	
-	-	-	-	-	1	2063440-1	AIR FEED MODULE	238	
-	-	1	1	-	-	2119740-2	TAG, IDENTIFICATION	213	
-	-	REFREF	-	-	-	1901697-1	FEED FINGER ASSEMBLY, EF	183	
-	1	1	1	1	1	1752354-5	STANDOFF, HOLD-DOWN	180	
-	1	1	1	1	1	6-993111-6	PIN, SLOTTED SPRING 3.0 X 14.0	177	
-	1	1	1	1	1	8-22280-7	SPRING, COMPRESSION	176	
-	1	1	1	1	1	1752353-2	GUIDE PIN, HOLDDOWN	175	
-	1	1	1	1	1	1901680-2	GUIDE PIN, HOLDDOWN	174	
-	-	-	-	2	-	21045-3	RING, RETAIN, EXTERN, 3/16 CRESCENT	172	
-	1	1	1	1	1	994969-1	MAGNET, RARE EARTH HIGH ENERGY	166	
-	REFREF	REFREF	REFREF	REFREF	REFREF	994970-2	COUNTER, MAGNETIC	164	
-	-	-	-	-	1	240638-1	SPRING, FEED FINGER	163	
-	-	-	-	-	1	3-23627-7	PIN, RETAIN, GRVD, 3/16 X .854	137	
-	-	REFREF	-	-	-	SEE NOTE 4	MEMORY CHIP, PROGRAMMED	135	
-	-	1	1	-	-	1633743-1	SERVO FEED LATCH ASM	133	
-	1	1	1	1	1	455888-7	SPACER, CRIMPER	82	
-	1	1	1	1	1	2119956-2	DOCUMENTATION PACKAGE	71	
-	2	2	2	2	2	2-18032-2	SCR, SET, FLT POINT M3 X 10.0	70	
-	1	-	-	1	1	2119740-1	TAG, IDENTIFICATION	67	
-	2	2	2	2	2	2168078-1	SCREW, DRIVE, RH, RoHS, 2 x .188	66	
-	1	1	1	1	1	1901681-5	HOLDDOWN, TERMINAL	65	
-	2	2	2	2	2	2168400-5	SHCS, LOW HEAD, RoHS, M4 X 20	64	
-	1	-	1	1	1	2119793-1	LIMITER, ADJUSTMENT BOLT	63	
-	3	-	3	3	3	992763-5	SCR, SET, SOC, CONE POINT, M3 X 4.0	62	
-	1	1	1	1	1	2079383-4	SCR, BHSC, RoHS (M4 X 8)	60	
-	-	-	-	-	1	5-18022-5	SCR, HEX HD CAP, M4 X 6.0	59	
-	-	-	-	-	1	2063961-1	FEED FINGER	58	
-	3	3	3	3	3	2168400-4	SHCS, LOW HEAD, RoHS, M4 X 8	57	
-	2	2	2	2	2	2168083-2	SCR, SKT HD CAP, RoHS, M4 X 8.0	56	
-	2	2	2	2	2	5018030-2	NUT, HEX, REG, RoHS, M4	55	
-	2	2	2	2	2	5018030-1	NUT, HEX, REG, RoHS, M3	54	
-	2	2	2	2	2	986965-8	NUT, LOCK, HEX, TORQUE (M4)	53	
-	1	1	1	1	1	1-5018030-0	NUT, HEX, REG, RoHS, M3.5	52	
-	-	-	-	-	1	2119792-2	PAWL, EF, AIR	51	
-	-	-	-	-	1	2	18023-9	SCR, SKT HD CAP M4 X 6.0	49
-	-	-	-	-	1	2119652-1	FEED CAM, PRE FEED	48	
-	-	-	-	-	1	2119653-1	FEED CAM, POST FEED	47	
-	1	1	1	1	1	2119655-5	APPLICATOR BASIC ASSEMBLY, EF	46	
-	1	-	1	1	1	2119369-1	RAM, AMP STYLE, END FEED	44	
-	1	1	1	1	1	2079383-7	SCR, BHSC, RoHS (M8 X 25)	41	
-	1	-	1	1	1	2119645-1	DISC, NUMBERED FA WIRE ADJUSTMENT	40	
-	1	-	1	1	1	2119957-1	APPLICATOR SHIM PACK	39	
-	1	1	1	1	1	2119644-1	RAM WASHER, PRECISION	38	
-	1	1	1	1	1	2119085-1	FA HEAD, ATLANTIC STYLE	37	
-	1	-	1	1	1	2119092-1	BOLT, ADJUSTMENT	35	
-	7	7	7	7	7	1-18028-2	WASHER, FLAT, REG M4	33	
-	2	2	2	2	2	2168083-9	SCR, SKT HD CAP, RoHS, M4 X 20	31	
-	2	2	2	2	2	1-2168083-0	SCR, SKT HD CAP, RoHS, M4 X 10	29	
-	1	1	1	1	1	240639-1	STRIPPER (MACHINING)	27	
-	2	2	2	2	2	1320906-1	STUD, THREADED	25	
-	1	1	1	1	1	1-1752371-6	PLATE, STRIP GUIDE	24	
-	1	1	1	1	1	240825-6	PLATE, STRIP HOLD DOWN	23	
-	2	2	2	2	2	2-22281-3	SPRING, COMPRESSION	22	
-	1	1	1	1	1	1752373-4	DRAG	20	
-	2	2	2	2	2	1901259-4	GUIDE, LOWER STRIP	18	
-	4	4	4	4	4	1-2079383-1	SCR, BHSC, RoHS (M6 X 12)	17	
-	1	1	1	1	1	4-240641-3	SPACER	16	
-	1	1	1	1	1	1-240644-7	PLATE, REAR SHEAR	11	
-	-	-	-	-	-	-	-	10	
-	1	1	1	1	1	3-690482-2	PLATE, FRONT SHEAR	9	
-	1	1	1	1	1	1-1803060-0	ANVIL, COMBINATION, END FEED	8	
-	1	1	1	1	1	1-2217206-0	BLADE, SLUG	7	
-	-	-	-	-	-	-	-	6	
-	1	1	1	1	1	240641-7	SPACER	5	
-	1	1	1	1	1	238009-4	BLOCK, FL CRIMPER SPACER	4	
-	1	1	1	1	1	2-1803016-3	CRIMPER, INSULATION F	3	
-	1	1	1	1	1	455888-4	SPACER, CRIMPER	2	
-	1	1	1	1	1	3-456405-4	CRIMPER, WIRE PREMIUM	1	
-77	-7	-6	-5	-2	-1	PART NO	DESCRIPTION	ITEM NO	

DIMENSIONS: mm		TOLERANCES UNLESS OTHERWISE SPECIFIED:		DRAWN: H. HUANG	DATE: 07AUG2014	TE Connectivity Harrisburg, PA 17105-3608
		0 PLC ±.5		CHK: L. ZHANG	DATE: 07AUG2014	
		1 PLC ±0.13		APVD: H. GUO	DATE: 07AUG2014	
		2 PLC ±0.013		NAME: Ocean End Feed Applicator		
		3 PLC ±0.008		PRODUCT SPEC: -		
		4 PLC ±0.001		APPLICATION SPEC: -		
		ANGLES ±.001		SIZE: A1		
MATERIAL: -		FINISH: -		WEIGHT: -		
				SCALE: 1:1		
				SHEET: 1 of 4		
				REV: A		

LOC		DIST		REVISIONS			
A	66	P	LTM	DESCRIPTION	DATE	OWN	APVD
		-		SEE SHEET 1			

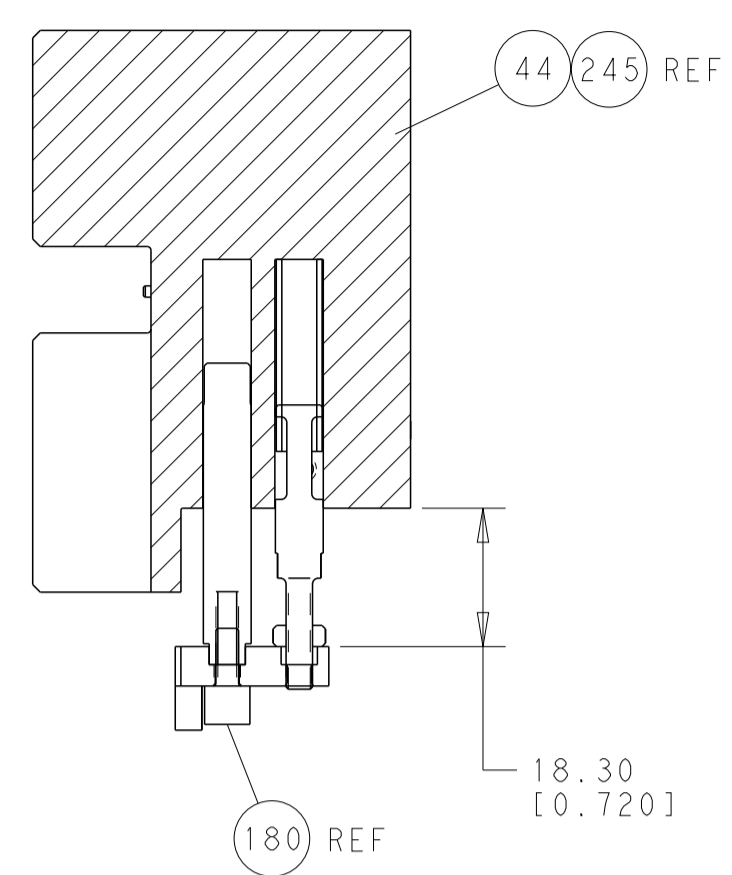

HOLDDOWN SET-UP

FEED TYPE
MECHANICAL

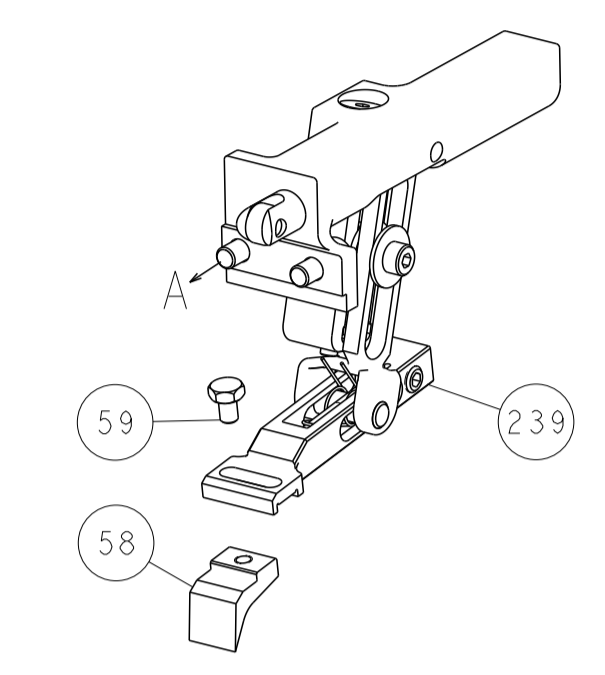

PNEUMATIC

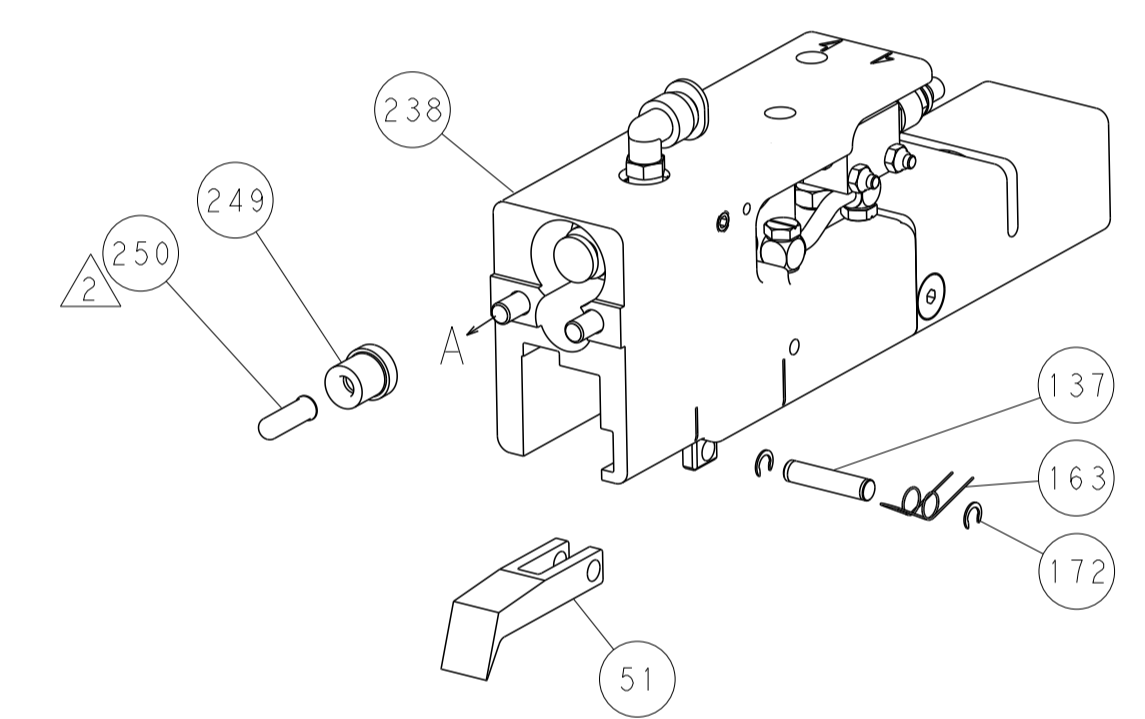

SERVO
LATCH PLATE

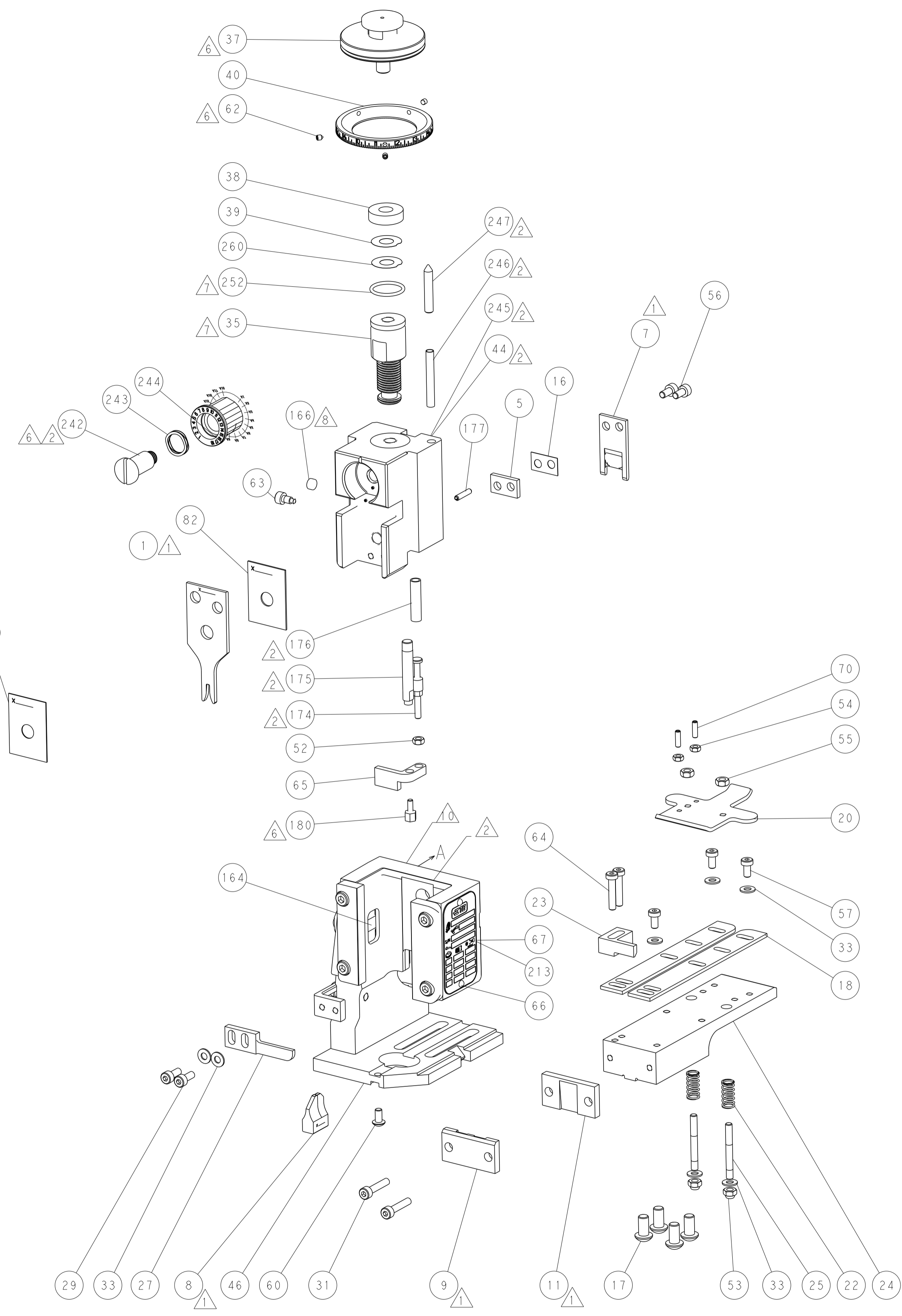
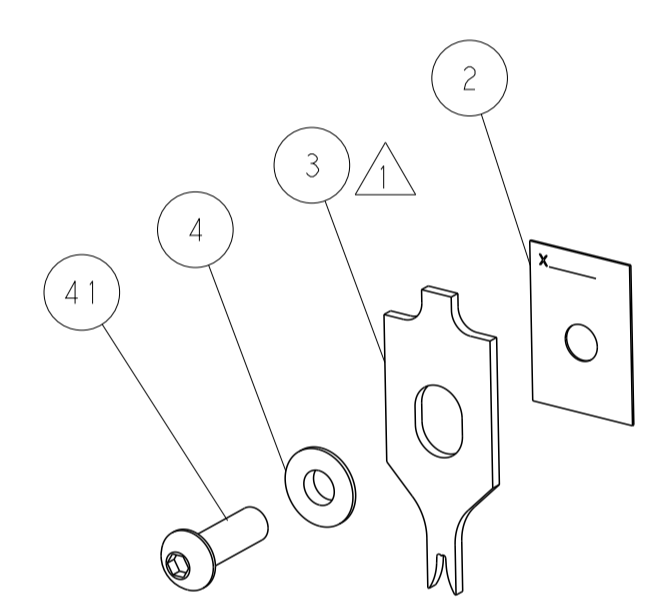
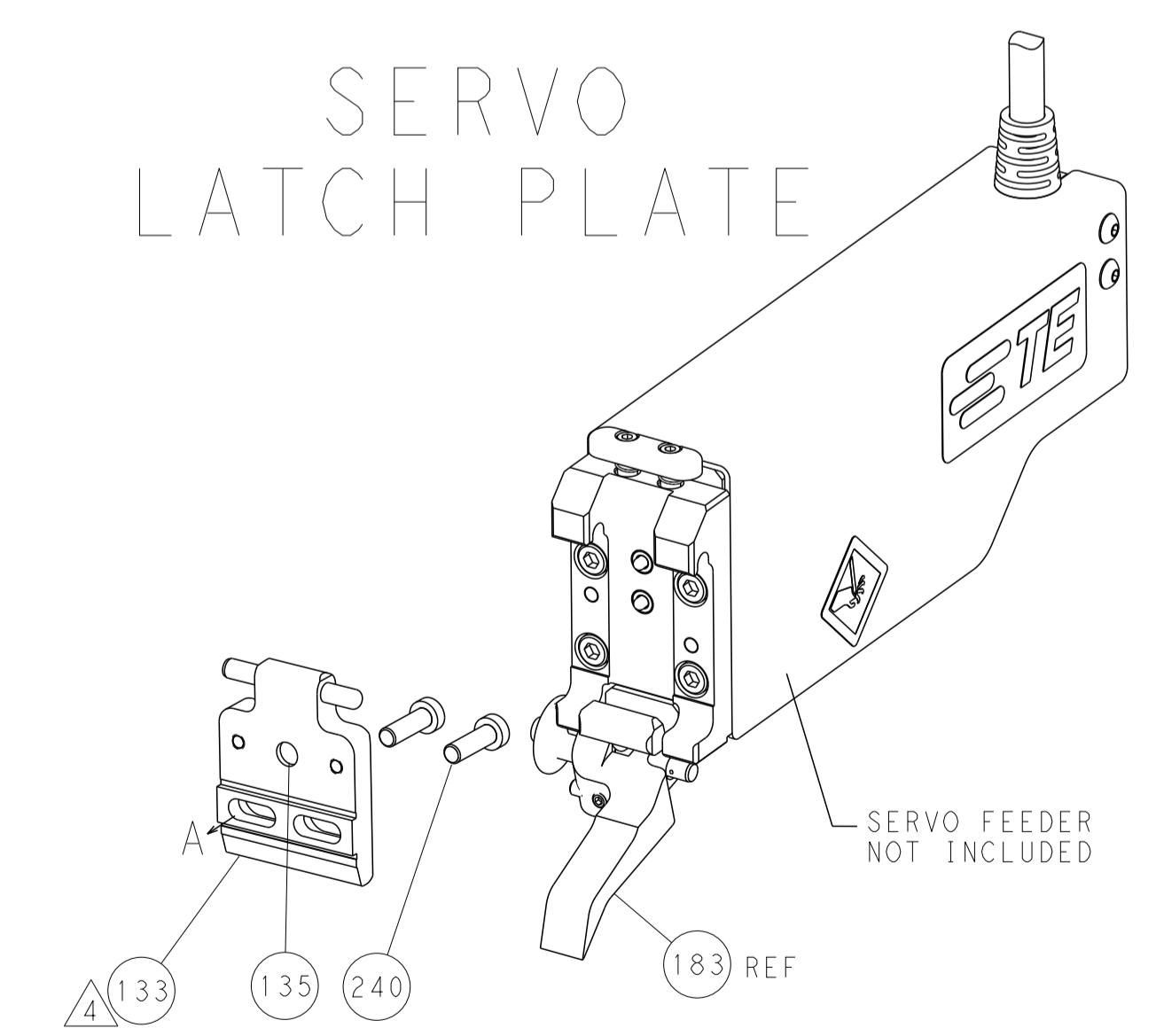

CAM POSITIONS

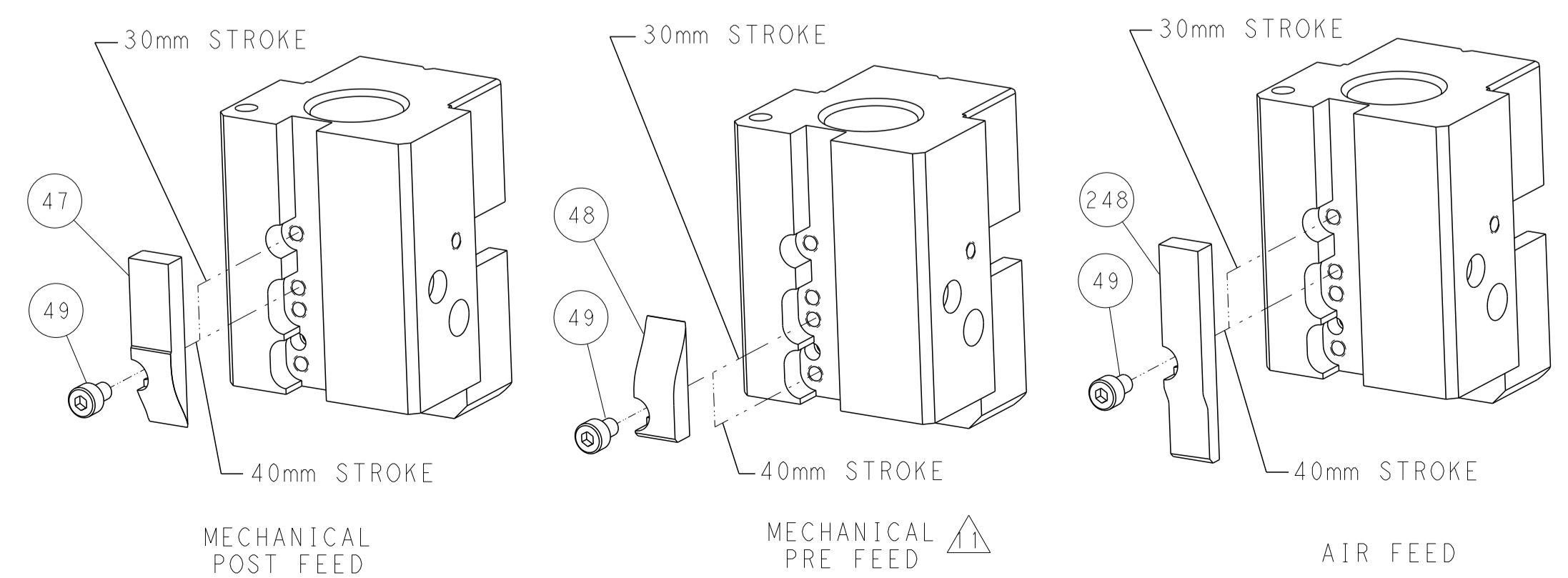

ATLANTIC VERSION
 Shown on sheets 1 of 4 & 2 of 4
 (Pacific version shown on sheets 3 of 4 & 4 of 4)

DIMENSIONS:		TOLERANCES UNLESS OTHERWISE SPECIFIED:		DWG: K. HUANG 07AUG2014		TE Connectivity	
mm		0 PLC ±0.5		CHK: L. ZHANG 07AUG2014		Harrisburg, PA 17105-3608	
Ø		1 PLC ±0.13		APPV: J. GUO 07AUG2014		NAME: Ocean End Feed Applicator	
H		2 PLC ±0.013		PRODUCT SPEC		SIZE: CAGE CODE: DRAWING NO: RESTRICTED TO	
D		3 PLC ±0.013		APPLICATION SPEC		A1 00779 ©=2150468	
R		4 PLC ±0.001		WEIGHT		SCALE: 1:1 SHEET 2 OF 4 REV A	
ANGLES		FINISH		Customer Accessible Production Drawing		SHEETS 3 & 4 ARE NOT REQUIRED FOR ATLANTIC VERSION	

PACIFIC VERSION TERMINATOR INTERFACE ADAPTER	PART NUMBER	REVISION	DESCRIPTION	FEED TYPE	APPLICATOR STYLE CONVERSION CHART						
					CONVERT TO	PART NUMBERS REQUIRED					
	2-2150468-1	A	FINE CRIMP HEIGHT ADJUST	MECHANICAL	PNEUMATIC FEED	2119950-1	2119792-2	-	2119641-2	-	2063440-1
					SERVO LATCH PLATE	2119951-1	1901697-1	8-2150468-5	-	-	2168400-7 (QUANTITY 2)
	2-2150468-2	A	FINE CRIMP HEIGHT ADJUST	PNEUMATIC	MECHANICAL FEED	2119949-1	2063961-1	5-18022-5	2119653-2	-	-
					SERVO LATCH PLATE	2119951-1	1901697-1	8-2150468-5	-	-	2168400-7 (QUANTITY 2)
					SMART APPLICATOR	2161326-1	-	8-2150468-4	-	-	-
	2-2150468-5	A	FINE CRIMP HEIGHT ADJUST	SERVO LATCH PLATE	MECHANICAL FEED	2119949-1	2063961-1	5-18022-5	2119653-2	-	-
	2-2150468-7	A	FINE CRIMP HEIGHT ADJUST	NONE	-	-	-	-	-	-	-
	7-2150468-7	A	CRIMP TOOLING KIT	-	-	-	-	-	-	-	-

APPLICATOR DATA		
CRIMP	SIZE	TYPE
WIRE	2.03 mm [.080]	F
INSUL	2.40 mm [.094]	F
APPL INSTRUCTIONS 408-10390		

TERMINAL DATA: STOCKO TERMINAL STOCKO CRIMP SPECIFICATION			
TERMINAL NAME: TERMINAL			
WIRE STRIP LENGTH		INSULATION DIAMETER RANGE	
3.00-4.00 mm [.118-.157 IN]		Ø 2.80 mm [.110 IN] MAX	
TERMINAL APPLICATION SPECIFICATION	F129 Rev -	-	-
TERMINALS APPLIED			
TE TERMINAL	STOCKO TERMINAL	TE TERMINAL	STOCKO TERMINAL
2113552-1	RSB7990.001 F 2.8-1		

WIRE SIZE	CRIMP HEIGHT mm [INCH]	CRIMP HEIGHT REFERENCE SETTING
1.00mm2	1.21+/-0.02 [.048+/- .001]	6.4
0.75mm2	1.13+/-0.02 [.044+/- .001]	7.1
20 AWG OR 0.50mm2	1.06+/-0.02 [.042+/- .001]	7.9

- RECOMMENDED SPARE PARTS
- GREASE BEARING SURFACES LIGHTLY
- 3. LUBRICATE DAILY PER THE APPLICATOR INSTRUCTION SHEET SUPPLIED WITH THE APPLICATOR.
- APPLICATOR SPECIFIC DATA TO BE ENTERED INTO BLANK MEMORY CHIP AT ASSEMBLY. SEE BELOW FOR PART NUMBER:
MECHANICAL FEED WITH "SMART APPLICATOR" CONVERSION: 8-2150468-4
PNEUMATIC FEED WITH "SMART APPLICATOR" CONVERSION: 8-2150468-4
SERVO FEED WITH "FINE CRIMP HEIGHT ADJUST": 8-2150468-5
- 5. ADJUSTMENT OF THE STRIPPER MAY BE REQUIRED WHEN MOVING THE APPLICATOR BETWEEN BENCH AND LEADMAKER APPLICATIONS.
- APPLY PART NUMBER 1-23419-5 LOCTITE TO THREADS OF ITEMS 62 & 180. APPLY PART NUMBER 2-23419-6 LOCTITE TO THREADS OF ITEM 242.
- GREASE THREADS, GROOVE AND O-RING ON ITEMS 139 & 153.
- MAGNET, ITEM 166 MUST BE ORIENTED CORRECTLY IN ORDER TO PROPERLY ACTUATE THE COUNTER.
- CRIMP HEIGHT REFERENCE SETTING WAS THE SETTING USED WHEN THE APPLICATOR WAS QUALIFIED AT THE FACTORY. ADJUSTMENT MAY BE NECESSARY WHEN RUNNING APPLICATOR IN THE FIELD.
- SPARE FEED CAM STORAGE LOCATION REFER TO INSTRUCTION SHEET FOR ADDITIONAL INFORMATION.
- THE RECOMMENDED SET-UP FOR END FEED APPLICATORS IS POST-FEED WITH ITEM 2119653-1. THE APPLICATOR CAN BE CONFIGURED FOR PRE-FEED WITH ITEM 2119652-1 BUT MAY ENCOUNTER PROBLEMS WITH SOME APPLICATIONS. FEED ISSUES OR TERMINAL JAMMING MAY OCCUR IN THE PRE-FEED CONFIGURATION.

***WARNING**
ON INSTALLATION, SET WIRE DISC, ITEM 40 TO LARGEST WIRE SIZE SETTING. USE OF SETTINGS BELOW MINIMUM REQUIRED CRIMP HEIGHT SETTING WILL CAUSE DAMAGE TO CRIMP TOOLING.

-	1	1	1	1	2119782-1	FINE ADJUST HEAD ASM, PACIFIC STYLE	251
-	-	-	1	-	2119640-1	PUSH ROD, AIR FEED	250
-	-	-	1	-	2079988-1	BUSHING, LCH5-12, MISUMI	249
-	1	1	1	1	1-22279-3	SPRING, COMPRESSION	246
-	1	1	1	1	2119082-3	CAM, SNAIL, INSULATION ADJUSTMENT	244
-	1	1	1	1	2079764-1	WASHER, WAVE SPRING, CREST-TO-CREST	243
-77-	27-	25-	22-	21	PART NO	DESCRIPTION	ITEM NO

PACIFIC VERSION
Shown on sheets 3 of 4 & 4 of 4
(Atlantic version shown on sheets 1 of 4 & 2 of 4)

SET UP GAUGE	LOC	DIST	REVISIONS			
2119599-2	A	66	REV	DATE	BY	APPD
-	-	-	1	SEE SHEET 1	-	-

	-	1	1	1	1	2119083-1	RETAINER, INSULATION DIAL	242
	-	-	2	-	-	2168400-7	SHCS, LOW HEAD, RoHS, M5 X 10	240
	-	-	-	1	-	2119580-1	MECHANICAL FEED ASSEMBLY	239
	-	-	-	1	-	2063440-1	AIR FEED MODULE	238
	-	-	1	-	-	2119740-2	TAG, IDENTIFICATION	213
	-	4	4	4	4	2079383-9	SCR, BHSC, RoHS (M6 X 20)	186
	-	-	REF	-	-	1901697-1	FEED FINGER ASSEMBLY, EF	183
	-	1	1	1	1	1752354-5	STANDOFF, HOLD-DOWN	180
	-	1	1	1	1	6-993111-6	PIN, SLOTTED SPRING 3.0 X 14.0	177
	-	1	1	1	1	8-22280-7	SPRING, COMPRESSION	176
	-	1	1	1	1	1752353-2	GUIDE PIN, HOLDDOWN	175
	-	1	1	1	1	1901680-2	GUIDE PIN, HOLDDOWN	174
	-	-	-	2	-	21045-3	RING, RETAIN, EXTERN, 3/16 CRESCENT	172
	-	1	1	1	1	994969-1	MAGNET, RARE EARTH HIGH ENERGY	166
	-	REF	REF	REF	REF	994970-2	COUNTER, MAGNETIC	164
	-	-	-	1	-	240638-1	SPRING, FEED FINGER	163
	-	1	1	1	1	8-21084-1	O-RING, .801 ID, .070 DIA. MAT.	153
	-	-	-	1	-	2119641-2	FEED CAM, AIR FEED	152
	-	1	1	1	1	2119798-2	DETENT PIN	145
	-	1	1	1	1	2079383-8	SCR, BHSC, RoHS (M4 X 16)	144
	-	-	-	-	1	2119653-2	FEED CAM, POST FEED	142
	-	1	1	1	1	2119655-6	APPLICATOR BASIC ASSEMBLY, EF	141
	-	1	1	1	1	2119651-1	RAM, ASIAN STYLE, END FEED	140
	-	1	1	1	1	2119092-2	BOLT, ADJUSTMENT	139
	-	-	-	1	-	3-23627-7	PIN, RETAIN, GRVD, 3/16 X .854	137
	-	-	REF	-	-	SEE NOTE 4	MEMORY CHIP, PROGRAMMED	135
	-	-	1	-	-	1633743-1	SERVO FEED LATCH ASM	133
	-	1	1	1	1	455888-7	SPACER, CRIMPER	82
	-	1	1	1	1	2119956-2	DOCUMENTATION PACKAGE	71
	-	2	2	2	2	2-18032-2	SCR, SET, FLT POINT M3 X 10.0	70
	-	1	-	1	1	2119740-1	TAG, IDENTIFICATION	67
	-	2	2	2	2	2168078-1	SCREW, DRIVE, RH, RoHS, 2 x .188	66
	-	1	1	1	1	1901681-5	HOLDDOWN, TERMINAL	65
	-	2	2	2	2	2168400-5	SHCS, LOW HEAD, RoHS, M4 X 20	64
	-	1	1	1	1	2119793-1	LIMITER, ADJUSTMENT BOLT	63
	-	3	3	3	3	992763-5	SCR, SET, SOC, CONE POINT, M3 X 4.0	62
	-	-	-	-	1	5-18022-5	SCR, HEX HD CAP, M4 X 6.0	59
	-	-	-	-	1	2063961-1	FEED FINGER	58
	-	3	3	3	3	2168400-4	SHCS, LOW HEAD, RoHS, M4 X 8	57
	-	2	2	2	2	2168083-2	SCR, SKT HD CAP, RoHS, M4 X 8.0	56
	-	2	2	2	2	5018030-2	NUT, HEX, REG, RoHS, M4	55
	-	2	2	2	2	5018030-1	NUT, HEX, REG, RoHS, M3	54
	-	2	2	2	2	986965-8	NUT, LOCK, HEX, TORQUE (M4)	53
	-	1	1	1	1	1-5018030-0	NUT, HEX, REG, RoHS, M3.5	52
	-	-	-	1	-	2119792-2	PAWL, EF, AIR	51
	-	-	-	1	2	18023-9	SCR, SKT HD CAP M4 X 6.0	49
	-	-	-	-	1	2119652-1	FEED CAM, PRE FEED	48
	-	1	1	1	1	2079383-7	SCR, BHSC, RoHS (M8 X 25)	41
	-	1	1	1	1	2119645-1	DISC, NUMBERED FA WIRE ADJUSTMENT	40
	-	1	1	1	1	2119957-1	APPLICATOR SHIM PACK	39
	-	1	1	1	1	2119644-1	RAM WASHER, PRECISION	38
	-	7	7	7	7	1-18028-2	WASHER, FLAT, REG M4	33
	-	2	2	2	2	2168083-9	SCR, SKT HD CAP, RoHS, M4 X 20	31
	-	2	2	2	2	1-2168083-0	SCR, SKT HD CAP, RoHS, M4 X 10	29
	-	1	1	1	1	240639-1	STRIPPER (MACHINING)	27
	-	2	2	2	2	1320906-1	STUD, THREADED	25
	-	1	1	1	1	1-1752371-6	PLATE, STRIP GUIDE	24
	-	1	1	1	1	240825-6	PLATE, STRIP HOLD DOWN	23
	-	2	2	2	2	2-22281-3	SPRING, COMPRESSION	22
	-	1	1	1	1	1752373-4	DRAG	20
	-	2	2	2	2	1901259-4	GUIDE, LOWER STRIP	18
	-	1	1	1	1	4-240641-3	SPACER	16
	-	1	1	1	1	1-240644-7	PLATE, REAR SHEAR	11
	-	-	-	-	-	-	-	10
	-	1	1	1	1	3-690482-2	PLATE, FRONT SHEAR	9
	1	1	1	1	1	1-1803060-0	ANVIL, COMBINATION, END FEED	8
	-	1	1	1	1	1-2217206-0	BLADE, SLUG	7
	-	-	-	-	-	-	-	6
	-	1	1	1	1	240641-7	SPACER	5
	-	1	1	1	1	238009-4	BLOCK, FL CRIMPER SPACER	4
	1	1	1	1	1	2-1803016-3	CRIMPER, INSULATION F	3
	-	1	1	1	1	455888-4	SPACER, CRIMPER	2
	1	1	1	1	1	3-456405-4	CRIMPER, WIRE PREMIUM	1

DIMENSIONS:		TOLERANCES UNLESS OTHERWISE SPECIFIED:		DATE		NAME	
mm	0 PLC ±.05	1 PLC ±.13	3 PLC ±.013	4 PLC ±.0001	APV	U. GUO	07AUG2014
	FINISH			CHK	L. ZHANG	07AUG2014	NAME
MATERIAL				APV	L. ZHANG	07AUG2014	PRODUCT SPEC
				APV	L. ZHANG	07AUG2014	APPLICATION SPEC
				WT			SIZE
				WT			CAGE CODE
				WT			DRAWING NO
				WT			RESTRICTED TO
				WT			SCALE
				WT			SHEET
				WT			OF
				WT			REV
				WT			A

LOC	DIST	REV	DATE	BY	APPV
A	66				

REVISIONS			
REV	DATE	BY	APPV
-	-	-	-
SEE SHEET 1			

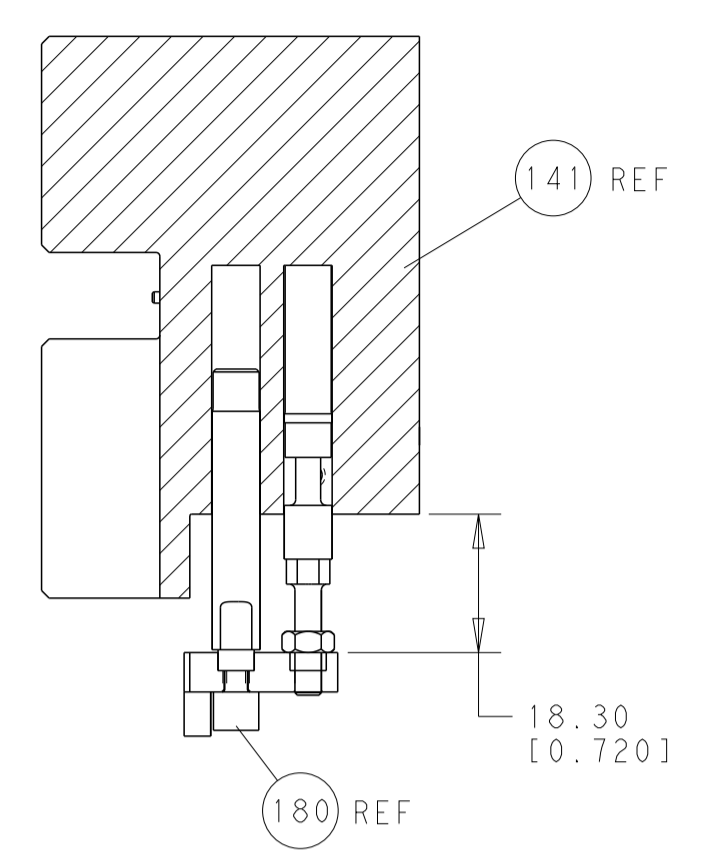

HOLDDOWN SET-UP

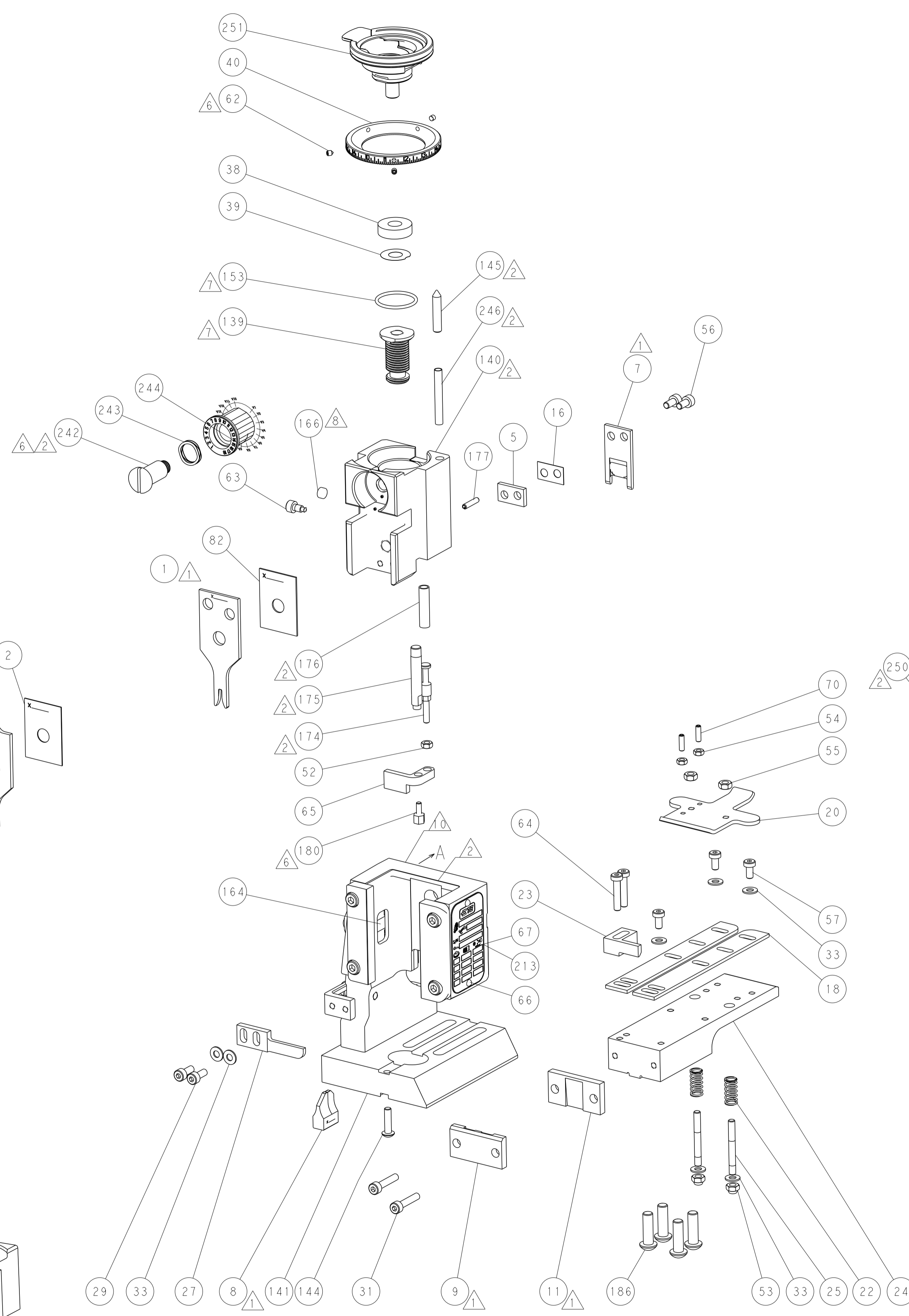

FEED TYPE
MECHANICAL

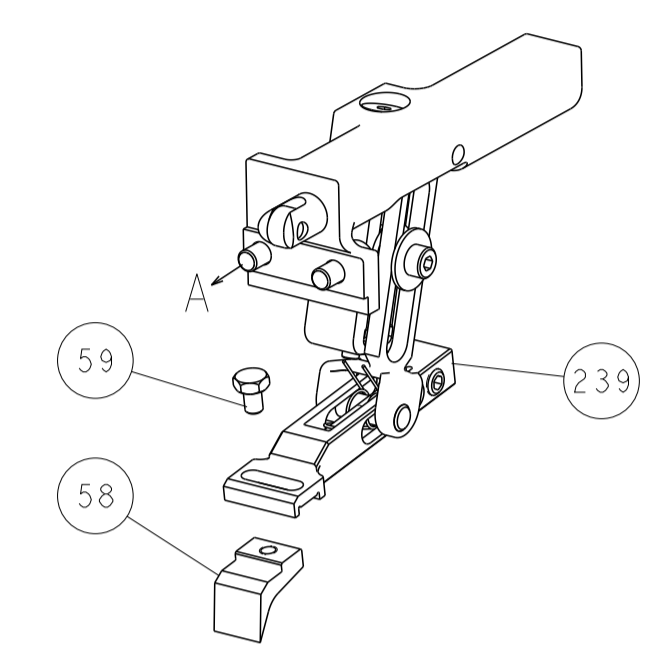

PNEUMATIC

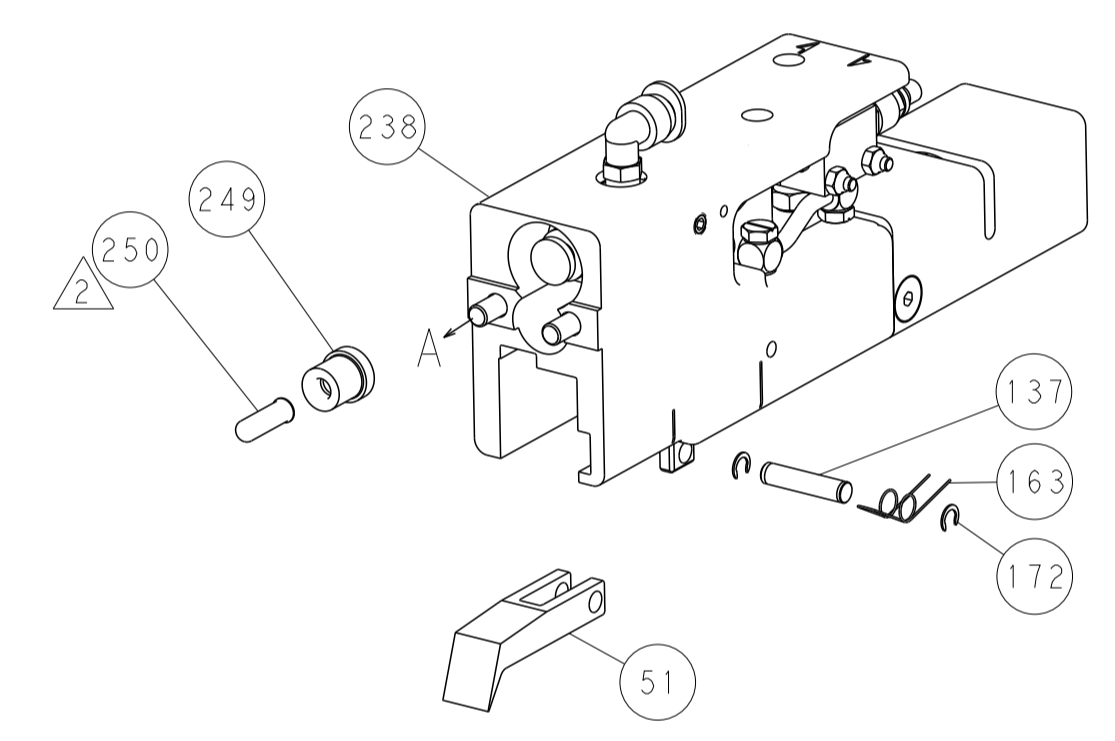

SERVO
LATCH PLATE

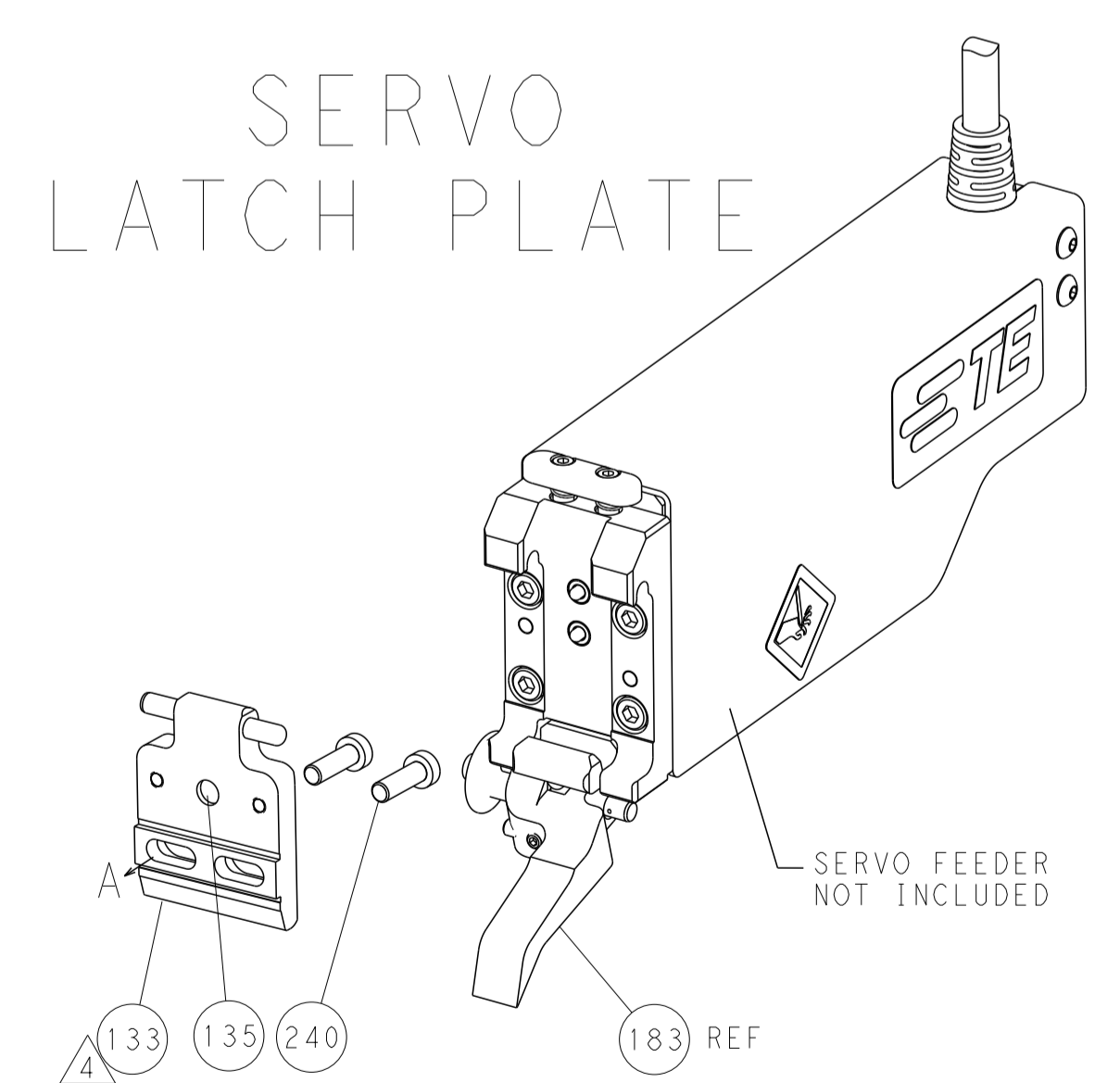

CAM POSITIONS

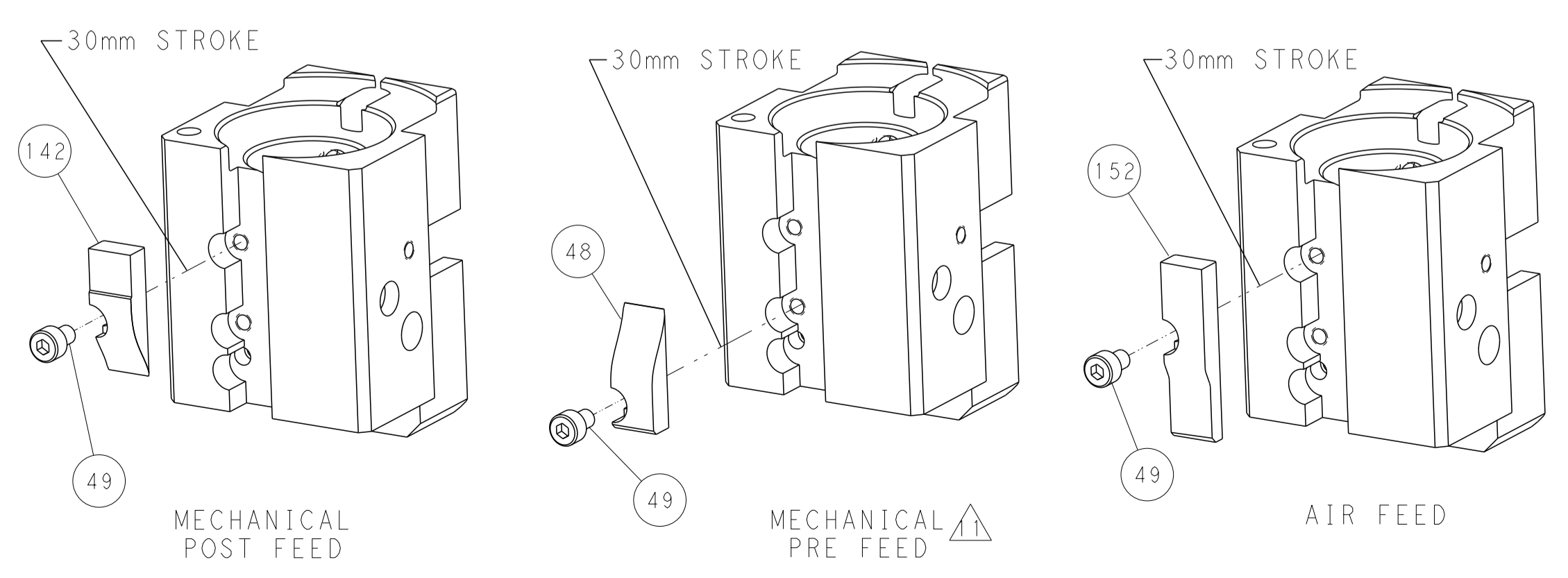

PACIFIC VERSION
 Shown on sheets 3 of 4 & 4 of 4
 (Atlantic version shown on sheets 1 of 4 & 2 of 4)

DIMENSIONS:		TOLERANCES UNLESS OTHERWISE SPECIFIED:		DWN H. HUANG 07AUG2014		STE TE Connectivity	
mm	0 PLC ±0.5	1 PLC ±0.5	2 PLC ±0.13	3 PLC ±0.013	4 PLC ±0.001	CHK L. ZHANG 07AUG2014	Harrisburg, PA 17105-3608
MATERIAL:	FINISH:	APVD JJ GUO 07AUG2014	NAME	SIZE	CAGE CODE	DRAWING NO	RESTRICTED TO
		PRODUCT SPEC		A1	00779	2150468	
		APPLICATION SPEC		Customer Accessible Production Drawing	SCALE 1:1	SHEET 4 OF 4	REV A