

Revision Level			Revision Record	Changed	Date	Approved	Date
Drawing	State	Part					
02.1	Design Release	-	SEE ECN# 013925	TAT	6/23/17	EJH	6/23/17

REFERENCE:

PERFORMANCE REQUIREMENTS AT DRY AS MOLDED:

1. FIR TREE PUSH IN FORCE: 45 NEWTONS (10 LBS) MAX IN THE APPLICABLE NOMINAL HOLE SIZE AND A PLATE THICKNESS OF 1.8mm.
2. FIR TREE PULL OUT FORCE: 155 NEWTONS (35 LBS) MIN IN THE APPLICABLE NOMINAL HOLE SIZE AND A PLATE THICKNESS OF 1.8mm.
3. SHEET METAL THICKNESS RANGE: 0.60mm - 5.5mm
4. APPLICABLE HOLE SIZE:
A. 6.5mm +0.5/- 0.4
5. FITS USCAR MATING HOLE EWCAP -007 (NOT A TEST SPEC.)

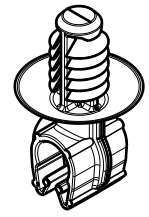
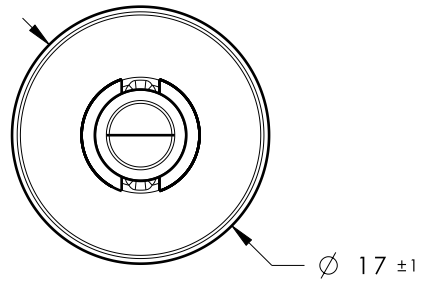

ISOMETRIC VIEW
SCALE 1:1

NOTES:

1. MAXIMUM PERCENT REGRIND PERMISSIBLE: 25%
2. MAX ALLOWABLE FLASH OR MISMATCH TO BE 0.5mm.

*PATENT PENDING 29/582,271

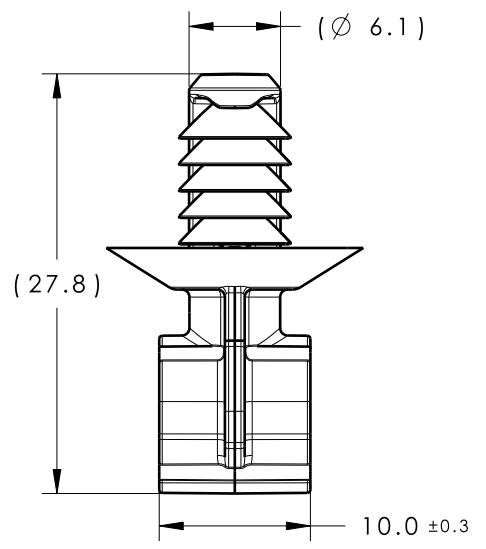
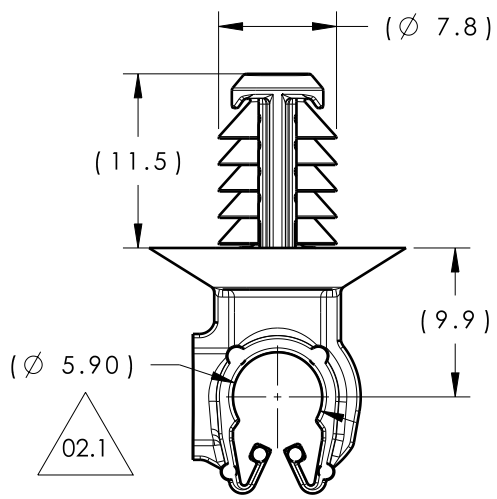

DIAMETER RANGE		
HARNESS	HOSE	HARD PIPE/TUBE
5.5MM-6.5MM	5.5MM-6.5MM	6.0MM-6.8MM

Material
PA66
COLOR: BLACK



Units **millimeters**

Tolerance defined on each dimension

The copyright of this drawing is reserved by HellermannTyton. It is issued on condition that it is not reproduced, copied or disclosed to a third party, either wholly or in part, without the consent of HellermannTyton.

Drawn **CRB** 08/04/16
Approved **EJH** 09/26/16

HellermannTyton

North America
Email: corp@htamericas.com
Web: www.hellermann.tyton.com

Article/Type-No **MOC6FT6.5**

Title **6MM (1/4") MODULAR OMEGA CLIP WITH 6.5MM FIR TREE**

Drawing-No **PROTOTYPE : Phase**

16-0314-009-CSU

Scale **2:1**

Project Number **16-0314**

Format **AH**

Sheet **1/1**